



## INTERNATIONAL APPLICATION PUBLISHED UNDER THE PATENT COOPERATION TREATY (PCT)

<p>(51) International Patent Classification <sup>5</sup> : A61F 5/44, 5/443, A61L 29/00</p>	A1	<p>(11) International Publication Number: <b>WO 91/17728</b></p> <p>(43) International Publication Date: 28 November 1991 (28.11.91)</p>
<p>(21) International Application Number: PCT/DK91/00129</p> <p>(22) International Filing Date: 14 May 1991 (14.05.91)</p> <p>(30) Priority data: 1201/90                      15 May 1990 (15.05.90)                      DK</p> <p>(71) Applicant (for all designated States except US): COLOPLAST A/S [DK/DK]; Egevangen 4, DK-2980 Kokkedal (DK).</p> <p>(72) Inventor; and (75) Inventor/Applicant (for US only) : WENDLER, Henrik, Gustav [DK/DK]; Vodroffslund 2, DK-1914 Frederiksberg C (DK).</p> <p>(74) Agents: SIMONSEN, Christian, Rosendal et al.; International Patent-Bureau, Høje Taastrup Boulevard 23, DK-2630 Taastrup (DK).</p>		<p>(81) Designated States: AT (European patent), AU, BE (European patent), CA, CH (European patent), DE (European patent), DK (European patent), ES (European patent), FI, FR (European patent), GB (European patent), GR (European patent), IT (European patent), JP, LU (European patent), NL (European patent), NO, SE (European patent), US.</p> <p><b>Published</b> <i>With international search report.</i> <i>In English translation (filed in Danish).</i></p>
<p>(54) Title: A THERMOPLASTIC URIDOM AND METHOD AND APPARATUS FOR ITS MANUFACTURE</p>		
<p>(57) Abstract</p> <p>A uridom for use as an external male catheter in a urinary incontinence device is manufactured by thermoplastic processing, using as base material a non-preprocessed compound material based on one or more thermoplastic, polystyrene-based block copolymers, preferably polystyrene polyethylene/butylene polystyrene copolymers, the elasticity of which has been enhanced through addition of a paraffinic process oil. In the thermoplastic processing a constricted tubular portion at one end of the device is produced by injection moulding in a tool, serving as drainage tube and connected to a tube, whereas a mainly cylindrical, thin-walled body portion (1) is produced integral with said tube portion by a subsequent controlled extrusion and blow moulding operation, during which operation the said tube portion is secured and retained in said tool, whereby not only said tube portion but also an adjacent end portion of the body portion are produced with controlled increased wall thickness as compared with the rest of the body portion.</p> <div style="text-align: right;"> </div>		

**FOR THE PURPOSES OF INFORMATION ONLY**

Codes used to identify States party to the PCT on the front pages of pamphlets publishing international applications under the PCT.

AT	Austria	ES	Spain	MG	Madagascar
AU	Australia	FI	Finland	ML	Mali
BB	Barbados	FR	France	MN	Mongolia
BE	Belgium	GA	Gabon	MR	Mauritania
BF	Burkina Faso	GB	United Kingdom	MW	Malawi
BG	Bulgaria	GN	Guinea	NL	Netherlands
BJ	Benin	GR	Greece	NO	Norway
BR	Brazil	HU	Hungary	PL	Poland
CA	Canada	IT	Italy	RO	Romania
CF	Central African Republic	JP	Japan	SD	Sudan
CG	Congo	KP	Democratic People's Republic of Korea	SE	Sweden
CH	Switzerland	KR	Republic of Korea	SN	Senegal
CI	Côte d'Ivoire	LI	Liechtenstein	SU	Soviet Union
CM	Cameroon	LK	Sri Lanka	TD	Chad
CS	Czechoslovakia	LU	Luxembourg	TG	Togo
DE	Germany	MC	Monaco	US	United States of America
DK	Denmark				

A thermoplastic uridom and method and apparatus for its manufacture.

The invention relates to a uridom for use as an external catheter in a male urinary incontinence device, manufactured by thermoplastic processing of a non-preprocessed thermoplastic elastomeric base material.

For aiding male urinary incontinence and for use in hospitals in connection with treatment and surgery of urethral disorders a urinary incontinence device is normally used, consisting of a uridom designed to be arranged as an external catheter on the penis and having a comparably short tube which via a hose is connected to a urine collection bag that is normally fastened to the user's leg.

Uridoms for use in such incontinence devices are produced in a conventional way like other elastic tubular sheaths to be fastened on parts of the human body, i.e. of natural latex by a multi-step dipping process, during which a mandrel of the same size and shape as the part of the body concerned is dipped repeatedly into a latex solution, which in between immersions is cured on the mandrel.

This known method which, i.a. is disclosed in the European Publication No.0 390720 suffers from several deficiencies in practice.

The latex used is thus a natural product, which may vary in respect of quality and composition and may i.a. contain allergy-inducing proteins, which in an industrial production is an impediment to ensuring a constant product uniformity with an optimum skin comfort. This is further intensified by the fact that the latex solution contains a vulcanization system, which among other substances contains nitrosamines and sulphur.

Furthermore, the lifetime of latex products is shortened by the fact that their structure contains double linkings which are sensitive when exposed to UV radiation, resulting in a decomposition of the material, whereby the properties of the product may deteriorate drastically.

In addition, this production method leaves much to be desired from an environmental and manufacturing point of view. In the process ammonia is employed and often also methanol and inorganic salts, wherefore a continuous destruction of chemical residues that are detrimental to the environment must take place. A possible waste resulting from a faulty production or excess material cannot be recycled but must be discarded and destroyed.

Also, the latex dipping method is a relatively lengthy process with a typical production lead time in the range of 24 hours, meaning that industrial mass production requires comprehensive machinery.

To alleviate or avoid these disadvantages a number of propositions have been made relating to the production of uridoms and similar products using different materials and methods.

The Danish patent application No.1549/79 thus discloses a method for manufacturing prophylactic devices such as condoms and fingerstalls by thermomoulding, whereby an extruded piece of a film of a thermoplastic polyurethane elastomer is deformed by means of a mandrel. The method thus requires a pre-processing of the PUR material into film and a subsequent extrusion into small units which in the moulding process are heated to a temperature high enough to soften the material.

Applying this method it is difficult to obtain the thin wall thickness, 150-200 u, which is required

of a uridom and, added to this, polyurethane does not have sufficiently good elastic properties to be a user-friendly alternative to the conventional latex uridoms, inasmuch as a polyurethane product will be  
5 perceived as tight.

In addition, base materials which are based on polyurethanes contain substances that are detrimental to the environment, such as, e.g. isocyanate.

US Patent No.4,817,593 discloses a method for  
10 manufacturing condoms by which a mandrel is dipped into a polyurethane solution in an organic solution and is cured at a high temperature. Contrary to the latex technology the mandrel is dipped into the solution only once, but the method does not remedy the  
15 above-mentioned deficiencies in using polyurethane as base material.

US Patent No.4,808,174 discloses a method for manufacturing condoms of plastics such as polyethylene, polypropylene or vinyl. The method is identical  
20 to the one described in the above-mentioned Danish patent application, i.e. preprocessed films are heated to a temperature which is high enough to soften them and are then moulded on a mandrel.

The Danish publication No.137 243 describes a  
25 method for manufacturing rubber products by repeated dipping into an elastomer solution consisting of a SBS or SIS block copolymer strained with 5-100 percentage by weight of a mainly naphtenic/aromatic petroleum oil and dissolved in 200/1200 percentage by weight of an  
30 aliphatic hydrocarbon, preferably petrol. The method first and foremost implies an environmental hazard, because comparably large quantities of solvents are employed and, furthermore, the thermoplastic block copolymers of the type described do not sufficiently  
35 remedy the problems of deterioration and wear which

are found in latex products. It has also been found that in uridoms manufactured by applying this method, a comparatively high decontraction occurs which may be due to a too low softening temperature, and which  
5 entails that a rolled-up uridom is difficult to unroll after only a few weeks of storage.

In the Danish publication No.150 792 a method for manufacturing uridoms is proposed, according to which an extruded hose-like body of thermoplastic and  
10 elastic material is blown up in a mould. As possible materials to be used for the extrusion of the tubular body are mentioned granulated latex, rubber or thermoplastic raw material. The method has never been put into practice and the description does not give any  
15 guidelines for solving the specific product-related and environmental problems mentioned above. The publication must be considered as a rather theoretical proposition for a production method as an alternative to the known latex dipping process without providing  
20 adequate documentation for its industrial applicability.

The published international patent application WO 89/11258 discloses a contraceptive condom made of thermoplastic material and manufactured by blow ex-  
25 trusion or blow moulding, where a tubular film body is either extruded by an embedded air bubble or heated and put in a mould and blown up by means of compressed air. Subsequently, one end portion of the tubular body is automatically sealed closed.

30 For functional reasons it is desirable that the part of the tube which serves as drainage tube should have a certain rigidity with a view to its being connected to a tube connector and, in order to achieve an anti-kinking function, it is preferred that in an ad-  
35 jacent end portion of the otherwise thin-walled body

portion a constriction should be provided to serve as an anti-kinking chamber.

The above-mentioned European patent application No.0390720 describes the manufacture of such a uridom  
5 by a conventional latex dripping process.

Against this background it is the object of the invention to provide a uridom having said properties, whereby not only the observed deficiencies and disadvantages inherent in latex products are eliminated,  
10 but also the unfortunate properties and unwarranted side effects of the alternative solutions described above.

According to the invention a uridom is characterized in that a tubular portion at one end of  
15 the uridom, serving as drain for connection to a tube is produced by injection moulding in a tool, whereas a mainly cylindrical and thin-walled body portion is produced integral with said tubular portion by a subsequent controlled pull extrusion and blow moulding  
20 process, during which said tubular portion, which has increased wall thickness, is secured and retained in said tool.

As compared with latex, a synthetic and well-defined material has been used as base material, which  
25 can be produced without any content of allergy-inducing substances or other substances that make the finished products less gentle to the skin. It has proved feasible to produce a uridom which has sufficient elasticity, so that the finished product relatively  
30 easily can be deformed and thereby is not perceived as tight, which also entails that a rolled-up uridom even after having been stored for a considerable length of time can be unrolled without major difficulty.

As the production method consists in a purely  
35 thermoplastic processing of a non-preprocessed base

material, the disadvantages related to the processing which are inherent in the known dipping methods are avoided, whether in these are employed latex solutions or other solutions such as possibly thermoplastic elastomers. The production method according to the invention represents a cleaner technology, insofar as no chemical residues are generated that may be detrimental to the environment and which have to be destroyed, and all waste or excess material from the production can be recycled, as it is generally known from the processing of thermoplastic materials.

Financially, this production method has the advantage that thermoplastic processing is of a short duration with a very short production lead time, as the process in principle merely comprises heating, moulding and cooling.

According to the invention, in addition to these process-related advantages a significantly enhanced freedom of choice in respect of product design is obtained, due to the combination of injection moulding and extrusion/blow moulding, among other things as concerns variations of the wall thickness in the longitudinal direction of the products.

A preferred embodiment is thus characterized in that one or more zones in the longitudinal direction of the body portion have an increased wall thickness as compared with the otherwise thin-walled body portion.

The invention also relates to a method for manufacturing the uridom, which method is characterized in that the said tubular portion is produced by injection moulding, during which process a thermoplastic base material is fed in a plastic state through a stationary first mould part to a pouring cavity in an adjacent movable second mould part, and



that after the injection moulding, by a pull extrusion operation, during which the said second mould part is moved away from the stationary first mould part, a hose-like member is produced which is integral with  
5 the said tube portion during continued feeding of the base material, and that the portion is produced by blow moulding of said portion in a cavity, the side walls of which are formed by mould wall parts introduced between said first and second mould part, and  
10 that the rate of speed in the movement of said second mould part away from the stationary first mould part during the pull extrusion operation is controlled to impart to the hose-like member a controlled increase of the wall thickness in one or more zones in the  
15 longitudinal direction of the body portion.

According to the invention, for production of uridoms, as said non-preprocessed compound materials are preferably employed one or more polystyrene polyethylene/butylene polystyrene block polymers, the  
20 elasticity of which has been increased by adding a paraffinic process oil. A particularly well suited base material can be obtained on the basis of the compound materials marketed by Shell Chemical Company under the trade name "KRATON-G-Polymers".

25 With a view to the injection moulding process forming part of the production method a slight amount of a release agent is preferably added to the base material.

The elasticity enhancing addition of said  
30 paraffinic oil will preferably be in the range of 60-85 parts of said process oil per 100 parts of the above-mentioned preferred compound material, whereby precisely the above-mentioned advantageous combination of material properties is obtained.

For use in manufacturing the uridom when applying the method described above an apparatus is devised which is characterized in that a stationary first mould part is formed with a mainly cone shell-shaped feeding duct for said base material in plastic state with a annular nozzle orifice in a side wall of said mould part, that a second injection mould part is arranged for movement towards and away from said side wall of the stationary mould part, and having a cylindrical pouring cavity which at one end is open towards the side wall of said mould part, designed for positioning against the annular nozzle orifice, control means being provided for moving the injection mould part away from the first mould part with securing and retaining of said tube portion during an extrusion operation, two blow mould parts being designed and positioned for introduction between the first mould part and the injection mould part for provision of mould walls for a blow moulding process.

The invention will be further explained in the following with reference to the schematical drawing, in which

Figs. 1 and 2 show sectional views of a preferred embodiment of a uridom according to the invention in rolled-up and unrolled form, respectively;

Figs. 3-6 illustrate the manufacture of the uridom through a combined injection moulding, pull extrusion and blow moulding process;

Figs. 7-10 show various alternative embodiments of the part of the uridom produced in the injection moulding process.

The uridom shown in Figs. 1 and 2 comprises a soft thin-walled and flexible body portion 1 with an open end 2. At the opposite end the body portion 1 contracts towards an end portion 3 having increased

wall thickness and rigidity as compared with the body portion 1.

The end portion 3 comprises a first portion 3a with a maximum interior diameter  $D_3$  corresponding to the interior diameter of the body portion 1 and a second portion 3b, which is integral with a narrow discharge or drainage tube 4, which by means of a tube can be connected to a not shown urine collection bag, which normally is fastened to one of the user's legs.

Between the first and second portion 3a and 3b of the end portion 1, a constriction 5 is provided, having such axial and radial dimensions, that the body portion 1 in the rolled-up supply condition shown in Fig. 1 can be received and retained in the constriction. The second portion 3b of end portion 3 between the constriction 5 and the drainage tube 4 converges towards the drainage tube 4 from a maximum diameter  $D_1$ , which is larger than the bottom diameter  $D_2$  of the constriction 5 in order to provide an anti-kinking chamber, which according to the prior art prevents kinking of the drainage tube 4 and thereby back-flow of urine during use of the uridom.

As shown in Fig. 2, part of the inner side of the body portion 1, as it is known per se from the International Patent Application W086/00816, can be provided with an integral layer 7 of a pressure-sensitive adhesive, and on the outer side with a matching adhesive-rejecting layer 8 in order to prevent successive windings in the rolled-up body portion 6 from sticking together.

Furthermore, with a view to the production method described in the following, the uridom is

provided, in the illustrated preferred embodiment, with a circumferential bead around the drainage tube.

As distinct from the conventional uridom designs as shown in Figs. 1 and 2, where the uridom is made of latex and produced by repeated dipping and curing operations as, e.g. disclosed in the above-mentioned US Patent Publication, the uridom according to the invention is produced by a method which solely involves thermoplastic processing of a base material in the form of a non-preprocessed compound material based on one or more thermoplastic, polystyrene-based block copolymers, the elasticity of which has been enhanced by adding a paraffinic process oil, which causes increased elasticity and which at the same time results in less force being required to unroll a rolled-up uridom.

As main component of the compound material are preferably used one or more polystyrene polyethylene/butylene polystyrene copolymers, preferably those marketed by Shell Chemical Company under the trade name "KRATON"-G-Polymers.

Tests have shown that especially a combination of the specific polymers designated KRATON-G-1650 and KRATON-G-1652 is well suited for producing uridoms in accordance with the invention.

The elasticity-enhancing addition of paraffinic oil should preferably be in the range of 60 to 85 parts of paraffinic process oil per 100 parts of said copolymers, as a smaller amount of additive has proved not to produce the desired effect in respect of elasticity enhancement and reduced decontraction and unrolling force, whereas a larger amount of additive results in an unwarranted reduction of the strength properties of the uridom.

In addition, with a view to the injection moulding process forming part of the production method, a release agent is added, as it is prescribed per se for use of the said polymer materials in  
5 injection moulding. In connection with the production of uridoms which are to be stuck to the penis either, as shown in Figs. 1 and 2 by means of an integral adhesive layer or by means of a separate adhesive strip, it has been found that the amount of additive  
10 release agent should be kept at a low level, wherefore the added release agent preferably is only 0.1 - 0.3 parts per 100 parts of polymer material. It has also been found that sufficiently good release properties can be achieved to ensure a stable production at the  
15 same time maintaining good adhesion properties of the applied pressure-sensitive adhesive.

In order to further illustrate the manufacturing of uridoms as shown in Figs. 1 and 2, the parts of a thermoplastic processing apparatus, which in principle is known from European Patent Publications Nos. 20 0278399, 0278400, 0278401 and 0278402, necessary for understanding the invention are shown in Figs. 3-5. Such an apparatus comprises, as shown in Fig. 3, a stationary first mould part 11 having a mainly cone-  
25 shell-shaped feeding duct 12 for feeding the above-mentioned base material in a plastic state. The feeding duct 12 opens in a side wall 13 of the mould part 11 with an annular nozzle orifice 14, which can be opened and closed by means of an axially mov-  
30 able nozzle cone 15, the conical outer side of which together with the inner wall of conical cavity 16 in the mould part 11 opening at the nozzle orifice make up the feeding duct 12. For closing of the nozzle orifice 14 the nozzle cone 15 has on the major  
35 part of its length a smaller apex angle than the con-

ical cavity 16. However, the extreme portion 15a of the nozzle cone, positioned in the nozzle orifice as shown in the enlarged sectional view of Fig. 6 is homothetic to the wall of the conical cavity 16  
5 around the nozzle orifice.

An injection moulding mould part 17 is arranged for movement towards and away from the side wall 13 of the stationary mould part 11 and comprises a tubular mould cavity 18, one end of which is  
10 open towards a side wall 19 for positioning against the nozzle orifice 14.

The tubular mould cavity has a diameter corresponding to the desired outer diameter of the drainage tube 4 of the uridom and an incision 20 for  
15 provision of the circular bead 9. As core element for provision of the clear of the drainage tube 4, a mandrel 21 is mounted in the nozzle cone 15 and connected to an axially movable piston rod 22, so that the mandrel 21 as shown in Fig. 3, during the  
20 injection moulding process can be pushed up into the mould cavity 18, which in its closed end has a depression with a reduced diameter to receive the end of the mandrel 21.

With the mandrel 21 in the position shown in  
25 Fig. 3 pushed into the mould cavity 18, the drainage tube 4 of the uridom is produced by injection moulding, the above-mentioned base material in a plastic state being fed through the feeding duct.

After cooling of the injection-moulded drainage  
30 tube the mandrel 21 is retracted into the nozzle cone 15 by means of the piston rod 22 to the position shown in Fig. 4, preparing for the next step of the thermoplastic processing which consists in a pull extrusion operation, during which the injection mould-  
35 ing mould part 17 and the injection-moulded drainage

tube 4 retained therein by means of the bead 9 in the incision 20 are moved away from the first mould part 11. During the pull extrusion process and during continuous feeding of the base material through the duct 12, a hose-like member 24 is produced as shown in Fig. 4, and for achievement of the increased wall thickness in the end portion 3 in Fig. 2 of the uridom the speed at which the injection mould part moves away from mould part 11 is controlled in a way so that it moves relatively slowly at first to obtain the increased product thickness as shown at 25 in Fig. 4, and picks up speed during manufacturing of the remaining part of the hose-like member 24, which during the subsequent blow moulding operation forms the thin-walled body portion of the uridom.

In order to ensure sufficient material supply for manufacturing the end portion 3 in Fig. 2 during the extrusion process, the above-mentioned shape of the tip of the nozzle cone 15, having a conicity homogeneous to the conicity of the cavity 16 around the nozzle orifice 14, so that on a short stretch a uniform width of the feeding duct 12 is obtained, has proved essential.

After the pull extrusion process the nozzle orifice 14 is closed by means of the nozzle cone 15, which assumes the position shown in Fig. 5. With the injection mould part 17 secured in the upper position, two mould wall parts 27 and 28 are introduced between mould parts 11 and 17 by a sideways movement to provide a mould cavity 29, having a contour corresponding to the body portion 1 of the uridom, and the extruded hose-like member is blown up in mould cavity 29 by injecting compressed air through the duct 30 provided in the mandrel 21.

After a short cooling time the uridom can be removed from the mould, cut at the open end and be placed on a mandrel and an adhesive and adhesive-rejecting layer be applied, after which the uridom is  
5 rolled up.

The invention is not limited to the examples given above, since as base material also other polystyrene-based block copolymers such as, e.g. SBS OR SIS polymers, to which the addition of paraffinic process oil will result in an enhanced elasticity, can be  
10 employed.

Furthermore, when applying the described method of manufacturing, the injection-moulded drainage tube can also be secured in the injection moulding mould  
15 part by means of a number of circular beads or other types of protrusions on the outer side of the drainage tube or, possibly, by providing the free end of the drainage tube with a protruding collar which is subsequently cut off.

As compared with the conventional manufacturing technology the combined injection moulding, pull extrusion and blow moulding gives a considerably increased freedom of choice in respect of the design of the drainage tube and the adjacent end portion of the  
20 uridom.  
25

Examples of this are shown in Figs. 7-10.

A high protection against kinking can thus be obtained as shown in Fig. 7 by designing at least a part 34 of the end portion of the uridom as a corrugated hull, which partly allows a significant angular displacement between the axial direction of the drainage tube and the uridom arranged on the penis, partly can absorb uridom tension and pressure loads. The hull portion 34, which has an increased wall  
30 thickness as compared with the body portion of the  
35



uridom is produced in the pull extrusion and blow moulding process through the above-mentioned control of the speed of the movable mould part, while using mould wall parts having a shape corresponding to the  
5 desired hull shape.

By providing the drainage tube 35 or 36 either with an inwards gripping collar 37 or an outwards gripping collar 38, as shown in Figs. 8 and 9, for engagement with a corresponding gripping device on  
10 a tube connector 39, 40, either in the form of a circumferential groove 41 on the outer side of the connector 39 inserted in the drainage tube 35, or in the form of one or several external gripping claws 42, a more reliable joint between the drainage tube  
15 and the hose leading to the collection bag is ensured. In order to facilitate insertion and removal of the connector the extreme end of the drainage tube may furthermore be of a conical shape.

By designing the drainage portion 43 as shown  
20 in Fig. 10 with a short length and a comparatively large clear and with external engagement members, e.g. in the form of a thread 46 for tight but removable connection to a tube connector, comprising an internal lining collar 44 and an external tube union 45, a  
25 uridom is produced which allows urination by internal catheterization without removal of the uridom, the increased clear providing direct access for application of a catheter in the exposed urethra by removing the tube connector 44.

## P A T E N T   C L A I M S

1. A uridom for use as an external catheter in a male urinary incontinence device, manufactured by thermoplastic processing of a non-preprocessed thermoplastic elastomeric base material, c h a r a c t e r -  
5 i z e d in that a tubular portion (4) at one end of the uridom, serving as drain for connection to a tube is produced by injection moulding in a tool, whereas a mainly cylindrical and thin-walled body portion (1) is produced integral with said tubular portion by a sub-  
10 sequent controlled pull extrusion and blow moulding process, during which said tubular portion, which has increased wall thickness, is secured and retained in said tool.

2. A uridom as claimed in claim 1, c h a r -  
15 a c t e r i z e d in that one or more zones in the longitudinal direction of the body portion have an increased wall thickness as compared with the otherwise thin-walled body portion (1).

3. A uridom as claimed in claim 2, c h a r -  
20 a c t e r i z e d in that said zone or zones comprise an end part (3) of the body portion positioned at the drainage tube portion (4).

4. A uridom as claimed in claim 3, c h a r -  
a c t e r i z e d in that said end portion (3) is  
25 provided with a circumferential constriction (5) to receive the body portion (1) in rolled-up condition and to provide a bulbous anti-kinking chamber (6).

5. A uridom as claimed in claim 3 or 4,  
c h a r a c t e r i z e d in that at least a part of  
30 the end portion of the uridom is shaped as a corrugated hull (34) allowing, on the one hand, a significant angular displacement between the axial

direction of said tubular portion and the applied uridom and, on the other hand, absorbing minor tension and pressure loads.

6. A uridom as claimed in claim 1, 2 or 3,  
5 c h a r a c t e r i z e d in that said tubular portion (35, 36) is constricted as compared to the body portion and is provided with either an inwards or outwards gripping collar (37, 38) for engagement with a corresponding gripping device (41, 42) on a tube con-  
10 nector (39, 40) connected to the tubular portion.

7. A uridom as claimed in claim 1, c h a r -  
a c t e r i z e d in that said tubular portion (43) has a short length and a comparably large orifice and is provided with external engagement members (46) for  
15 tight but removable connection to a tube connector (45) allowing internal catheterization without removal of the uridom.

8. A uridom as claimed in one of the preceding claims, c h a r a c t e r i z e d in that the thin-  
20 walled body portion if provided with an internal layer of a pressure-sensitive adhesive and with a view to supply in rolled-up condition has an adhesive-rejecting layer on the outside.

9. A method of manufacturing a uridom as claim-  
25 ed in one of the preceding claims, c h a r a c t e r -  
i z e d in that said tubular portion (4) is produced by injection moulding, during which process a thermo-  
plastic base material is fed in a plastic state through a stationary first mould part (11) to a pour-  
30 ing cavity (18) in an adjacent movable second mould part (17), and that after the injection moulding, by a pull extrusion operation, during which said second mould part (17) is moved away from the stationary first mould part (11), a hose-like member (24) is pro-  
35 duced which is integral with said tube portion (4)

during continued feeding of the base material, and that the body portion (1) is produced by blow moulding of said portion (24) in a cavity (29), the side walls of which are formed by mould wall parts (27, 28) introduced between said first and second mould part (11, 17).

10 10. A method as claimed in claim 9, characterized in that the rate of speed in the movement of said second mould part (17) away from the stationary first mould part (11) during the pull extrusion operation is controlled to impart to the hose-like member (24) a controlled increase of the wall thickness in one or more zones in the longitudinal direction of the body portion (1).

15 11. A method as claimed in claim 9 or 10, characterized in that as base material are used one or more polystyrene polyethylene/butylene polystyrene copolymers, the elasticity of which has been enhanced by addition of a paraffinic process oil.

20 12. A method as claimed in one of the claims 9-12, characterized in that a small amount of release agent has been added to the base material.

25 13. A method as claimed in claim 12, characterized in that the amount of added paraffinic process oil is 60-85 parts per 100 parts of said polystyrene polyethylene/butylene polystyrene copolymers.

30 14. A method as claimed in claim 12, characterized in that the amount of added release agent is 0.1-0.3 parts per 100 parts of said polystyrene polyethylene/butylene polystyrene copolymers.

35 15. An apparatus for manufacturing a uridom as claimed in one of the claims 1-8, while applying the method as claimed in one of claims 9-14, characterized

a c t e r i z e d in that a stationary first mould part (11) is formed with a mainly cone shell-shaped feeding duct (12) for said base material in plastic state with a annular nozzle orifice (14) in a side wall (13) of said mould part, that a second injection mould part (17) is arranged for movement towards and away from said side wall (13) of the stationary mould part (11) and having a cylindrical pouring cavity (18), which at one end is open towards side wall (19) of said mould part (17), designed for positioning against the annular nozzle orifice (14), control means being provided for moving the injection mould part (17) away from the first mould part (11) with securing and retaining of said tube portion (4) during an extrusion operation, two blow mould parts (27, 28) being designed and positioned for introduction between the first mould part (11) and the injection mould part (17) for provision of mould walls for a blow moulding process.

20 16. An apparatus as claimed in claim 15, characterized in that a mandrel (21) placed in the said pouring cavity (18) during the injection moulding process is connected to a piston (22) journaled in the stationary first mould part (11) for pulling the mandrel into the first mould part (11) prior to the extrusion operation.

17. An apparatus according to claim 15, characterized in that the pouring cavity has at its other end a constricted extension (23) to receive the end of said mandrel (21) during the injection moulding process.

18. An apparatus as claimed in claim 15, characterized in that the feeding duct (12) is provided between the wall of conical cavity (16) opening at the nozzle orifice (14) and the nozzle

nozzle cone (15) coaxially positioned in said cavity, said nozzle cone having on the major part of its length a smaller apex angle than said conical cavity for closing of the nozzle orifice (14), whereas the  
5 extreme portion (15a) of the nozzle cone (15), positioned in the orifice is homothetic to the wall of said conical cavity (16).

FIG. 1

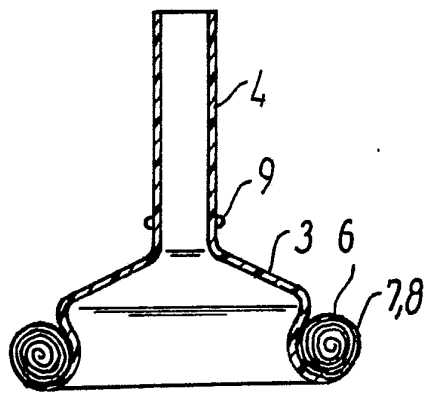
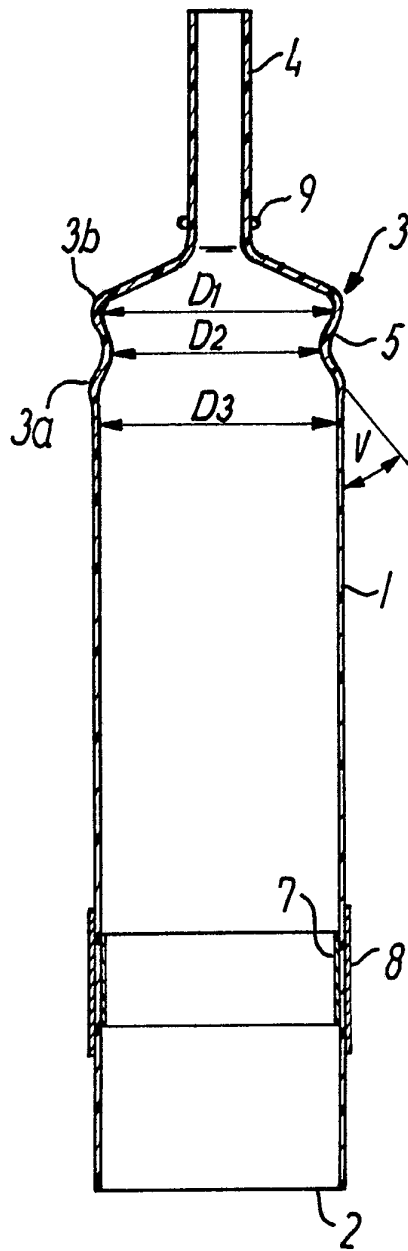
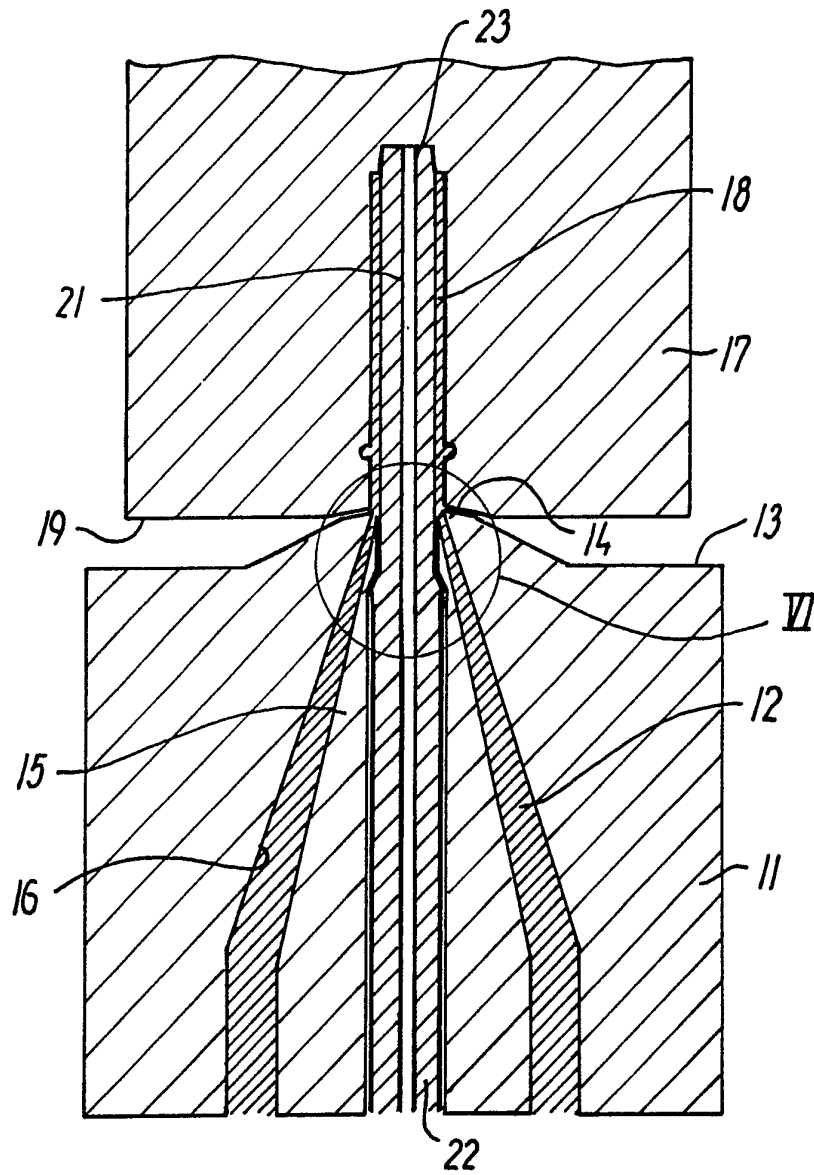

FIG. 2







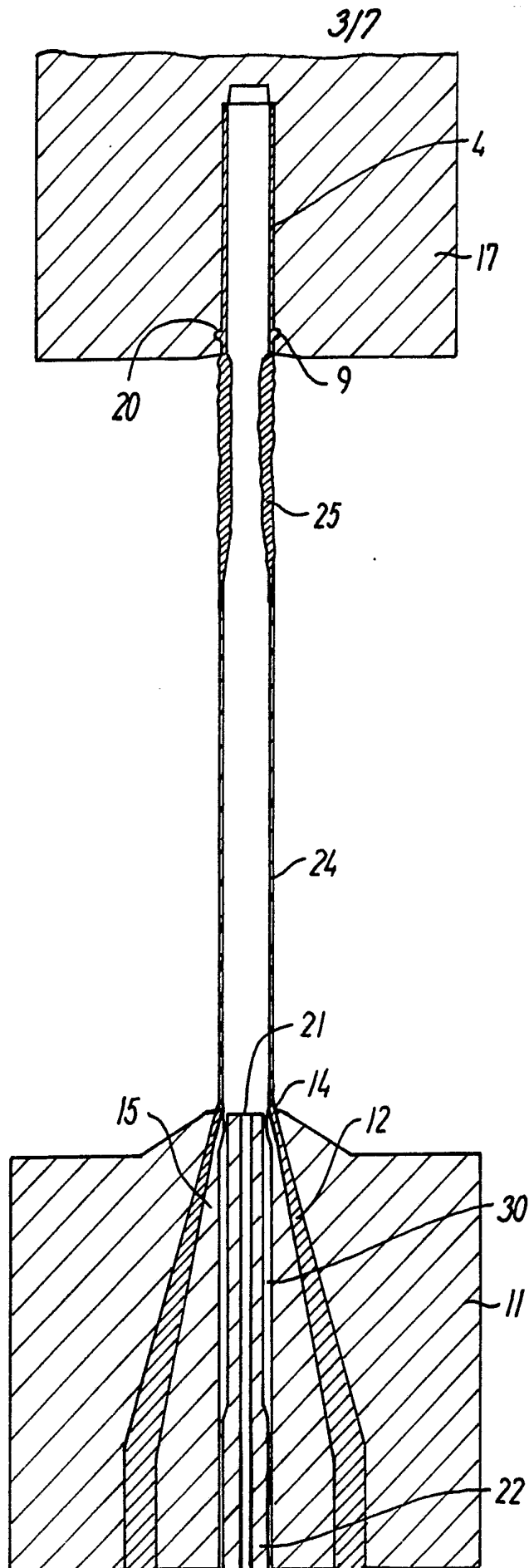
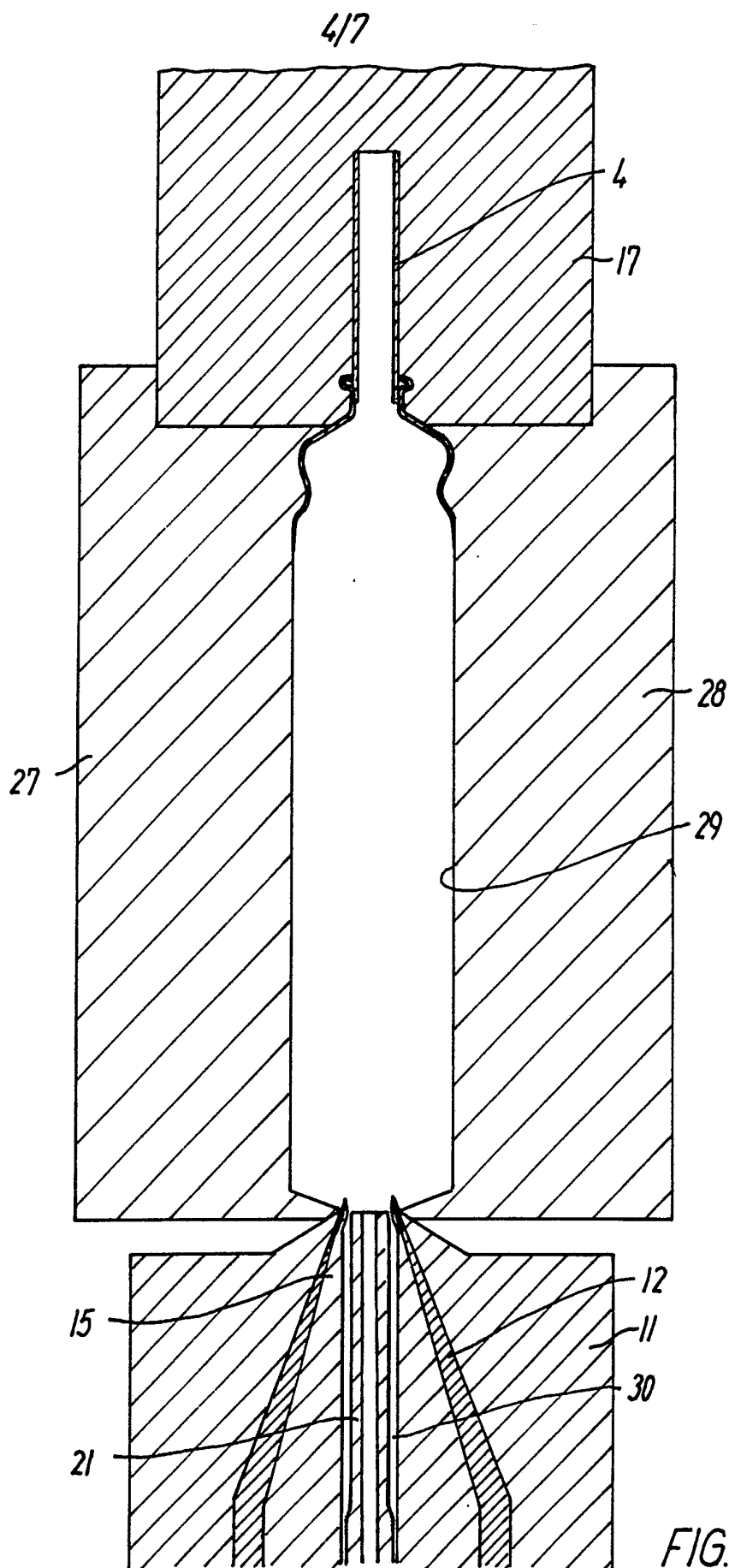

FIG. 4



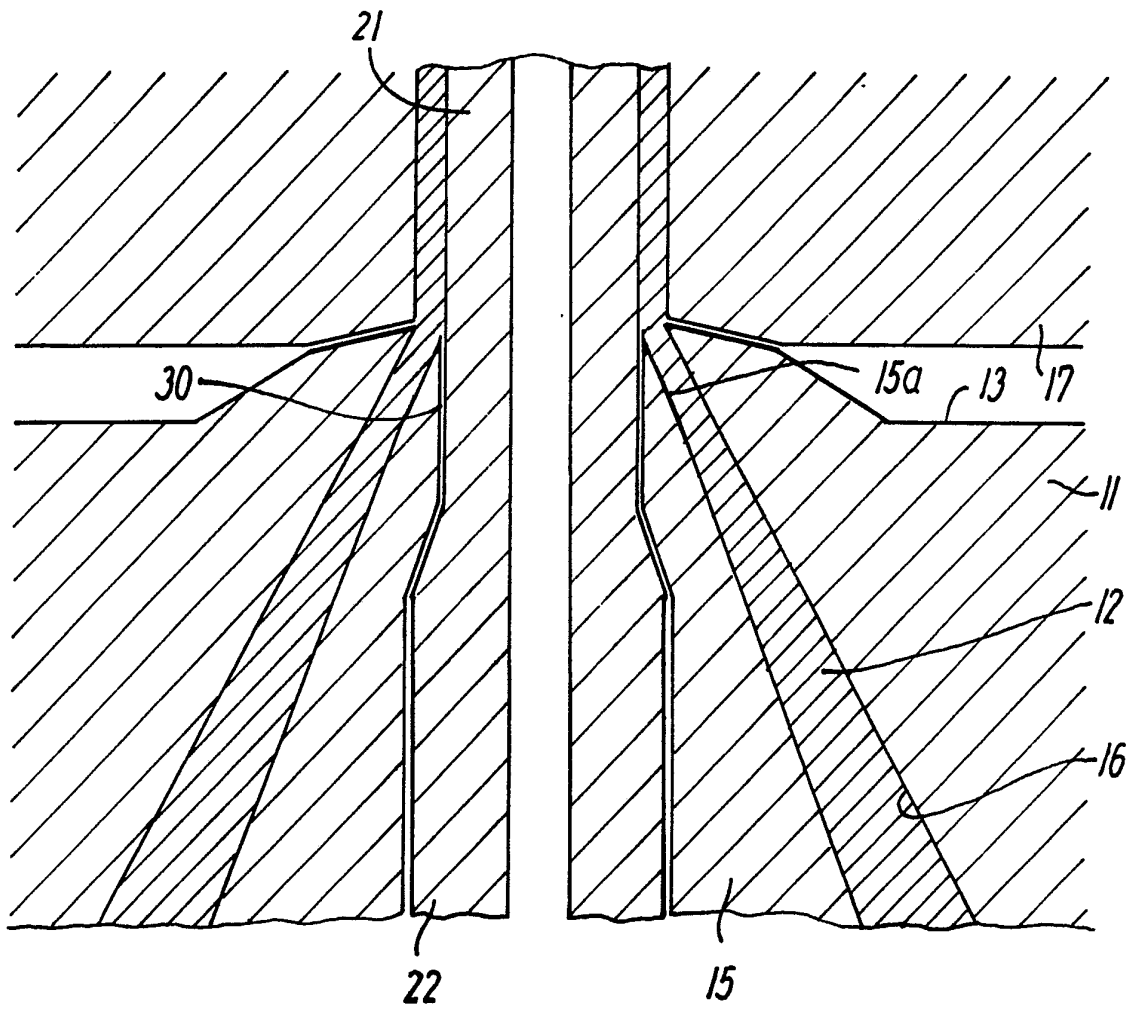

FIG. 6

6/7

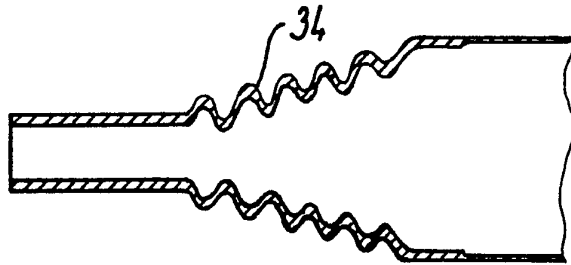

FIG. 7

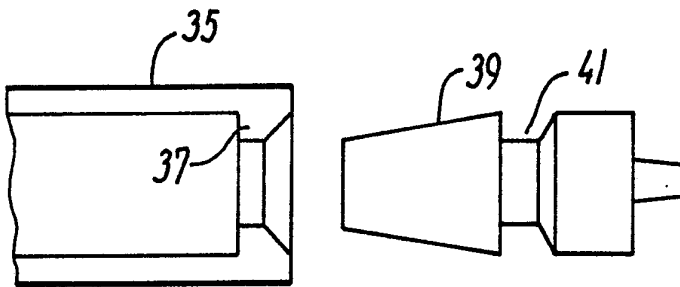

FIG. 8

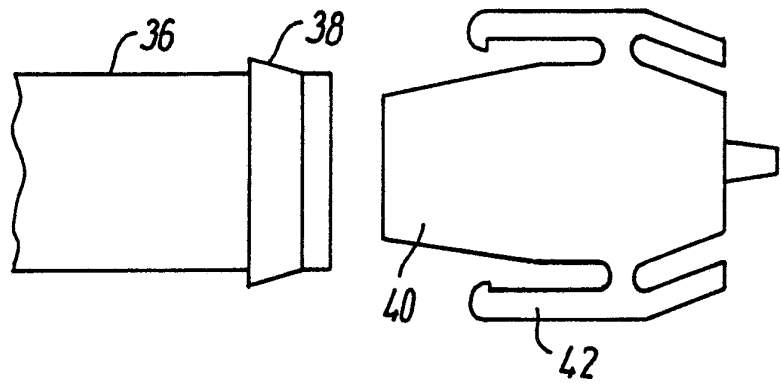

FIG. 9

7/7

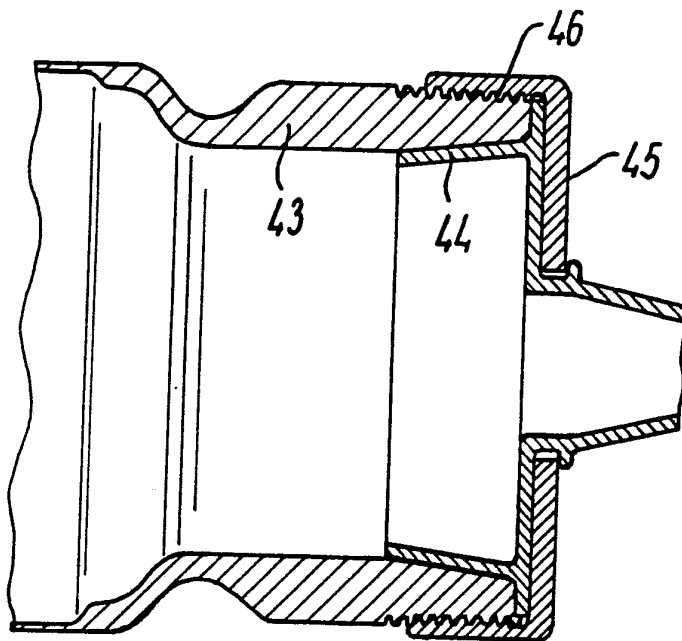
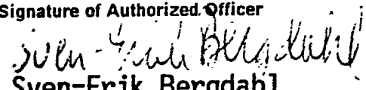

FIG. 10

# INTERNATIONAL SEARCH REPORT

International Application No **PCT/DK 91/00129**

<b>I. CLASSIFICATION OF SUBJECT MATTER</b> (if several classification symbols apply, indicate all) <sup>6</sup>		
According to International Patent Classification (IPC) or to both National Classification and IPC		
IPC5: A 61 F 5/44, 5/443, A 61 L 29/00		
<b>II. FIELDS SEARCHED</b>		
Minimum Documentation Searched <sup>7</sup>		
Classification System	Classification Symbols	
IPC5	A 61 F	
Documentation Searched other than Minimum Documentation to the Extent that such Documents are Included in Fields Searched <sup>8</sup>		
SE,DK,FI,NO classes as above		
<b>III. DOCUMENTS CONSIDERED TO BE RELEVANT<sup>9</sup></b>		
Category *	Citation of Document, <sup>11</sup> with indication, where appropriate, of the relevant passages <sup>12</sup>	Relevant to Claim No. <sup>13</sup>
Y	DK, B, 150792 (COLOPLAST A/S) 22 June 1987, see the whole document	1-4,5-7, 12-18 8,9
A	--	
Y	US, A, 4551490 (DOYLE ET AL) 5 November 1985, see column 2, line 12 - line 23; column 2, line 37 - line 52; column 5, line 33 - line 51	1-4,11- 14
Y	US, A, 4062361 (POULSEN) 13 December 1977, see column 3, line 53 - line 60	1-4
Y	EP, A2, 0278400 (OSSBERGER-TURBINENFABRIK GMBH & CO.) 17 August 1988, see the whole document	1-4,9- 18
	--	
<p>* Special categories of cited documents:<sup>10</sup></p> <p>"A" document defining the general state of the art which is not considered to be of particular relevance</p> <p>"E" earlier document but published on or after the international filing date</p> <p>"L" document which may throw doubts on priority claim(s) or which is cited to establish the publication date of another citation or other special reason (as specified)</p> <p>"O" document referring to an oral disclosure, use, exhibition or other means</p> <p>"P" document published prior to the international filing date but later than the priority date claimed</p> <p>"T" later document published after the international filing date or priority date and not in conflict with the application but cited to understand the principle or theory underlying the invention</p> <p>"X" document of particular relevance, the claimed invention cannot be considered novel or cannot be considered to involve an inventive step</p> <p>"Y" document of particular relevance, the claimed invention cannot be considered to involve an inventive step when the document is combined with one or more other such documents, such combination being obvious to a person skilled in the art.</p> <p>"&amp;" document member of the same patent family</p>		
<b>IV. CERTIFICATION</b>		
Date of the Actual Completion of the International Search	Date of Mailing of this International Search Report	
9th August 1991	1991 -08- 15	
International Searching Authority	Signature of Authorized Officer	
SWEDISH PATENT OFFICE	 Sven-Erik Bergdahl	

III. DOCUMENTS CONSIDERED TO BE RELEVANT (CONTINUED FROM THE SECOND SHEET)		
Category *	Citation of Document, with indication, where appropriate, of the relevant passages	Relevant to Claim No
Y	EP, A2, 0278399 (OSSBERGER-TURBINENFABRIK GMBH & CO.) 17 August 1988, see the whole document --	9,10,15-18
Y	EP, A2, 0278402 (OSSBERGER-TURBINENFABRIK GMBH & CO.) 17 August 1988, see the whole document -- -----	9,10,15-18

**ANNEX TO THE INTERNATIONAL SEARCH REPORT  
ON INTERNATIONAL PATENT APPLICATION NO.PCT/DK 91/00129**

This annex lists the patent family members relating to the patent documents cited in the above-mentioned international search report. The members are as contained in the Swedish Patent Office EDP file on **91-06-27**. The Swedish Patent Office is in no way liable for these particulars which are merely given for the purpose of information.

Patent document cited in search report	Publication date	Patent family member(s)	Publication date
DK-B- 150792	87-06-22	NONE	
US-A- 4551490	85-11-05	AU-B- 578612 AU-D- 2950184 CA-A- 1225764 DE-A- 3473731 EP-A-B- 0130061 JP-A- 60020976	88-11-03 85-01-10 87-08-18 88-10-06 85-01-02 85-02-02
US-A- 4062361	77-12-13	AT-B- 342759 BE-A- 831128 CH-A- 618340 DE-A-C- 2530238 FR-A-B- 2277597 JP-C- 1158125 JP-A- 51031096 JP-B- 57053097 NL-A- 7508114 SE-B-C- 405934 SE-A- 7507681	78-04-25 75-11-03 80-07-31 76-01-29 76-02-06 83-07-25 76-03-16 82-11-11 76-01-12 79-01-15 76-01-09
EP-A2- 0278400	88-08-17	DE-A-C- 3704265 EP-A- 0278402 JP-A- 63202421 JP-A- 63202422 US-A- 4806091 US-A- 4808105 ZA-A- 8800619 ZA-A- 8800621	88-08-25 88-08-17 88-08-22 88-08-22 89-02-21 89-02-28 88-08-02 88-08-02
EP-A2- 0278399	88-08-17	DE-A-C- 3704266 JP-A- 63199625 US-A- 4806093 ZA-A- 8800618	88-08-25 88-08-18 89-02-21 88-08-02
EP-A2- 0278402	88-08-17	DE-A-C- 3704265 EP-A- 0278400 JP-A- 63202421 JP-A- 63202422 US-A- 4806091 US-A- 4808105 ZA-A- 8800619 ZA-A- 8800621	88-08-25 88-08-17 88-08-22 88-08-22 89-02-21 89-02-28 88-08-02 88-08-02