



(51) International Patent Classification:

B03C 3/38 (2006.01) B03C 3/40 (2006.01)  
B03C 3/12 (2006.01)

(21) International Application Number:

PCT/KR2012/001033

(22) International Filing Date:

10 February 2012 (10.02.2012)

(25) Filing Language:

English

(26) Publication Language:

English

(30) Priority Data:

10-2011-0114659 4 November 2011 (04.11.2011) KR

(71) Applicant (for all designated States except US): **ROYAL INDUSTRIAL TECH CORP.** [KR/KR]; 63, Non-hyeon-ro 63-gil, Gangnam-gu (Yeoksam-dong), Seoul, Seoul 135-080 (KR).

(72) Inventor; and

(75) Inventor/Applicant (for US only): **CHUNG, Jong Seung** [KR/KR]; D-1202, The sharp starcity 227-7, Jayang-dong, Gwangjin-gu, Seoul, Seoul 143-190 (KR).

(74) Agent: **CHU, Heonuk**; DONGSUNG Bldg., 5th Floor, 61 Banpo-daero 20-gil, Seocho-gu (Seochodong), Seoul, DaVinci Law Group Patent Team, Seoul 137-874 (KR).

(81) Designated States (unless otherwise indicated, for every

kind of national protection available): AE, AG, AL, AM, AO, AT, AU, AZ, BA, BB, BG, BH, BR, BW, BY, BZ, CA, CH, CL, CN, CO, CR, CU, CZ, DE, DK, DM, DO, DZ, EC, EE, EG, ES, FI, GB, GD, GE, GH, GM, GT, HN, HR, HU, ID, IL, IN, IS, JP, KE, KG, KM, KN, KP, KZ, LA, LC, LK, LR, LS, LT, LU, LY, MA, MD, ME, MG, MK, MN, MW, MX, MY, MZ, NA, NG, NI, NO, NZ, OM, PE, PG, PH, PL, PT, QA, RO, RS, RU, RW, SC, SD, SE, SG, SK, SL, SM, ST, SV, SY, TH, TJ, TM, TN, TR, TT, TZ, UA, UG, US, UZ, VC, VN, ZA, ZM, ZW.

(84) Designated States (unless otherwise indicated, for every

kind of regional protection available): ARIPO (BW, GH, GM, KE, LR, LS, MW, MZ, NA, RW, SD, SL, SZ, TZ, UG, ZM, ZW), Eurasian (AM, AZ, BY, KG, KZ, MD, RU, TJ, TM), European (AL, AT, BE, BG, CH, CY, CZ, DE, DK, EE, ES, FI, FR, GB, GR, HR, HU, IE, IS, IT, LI, LU, LV, MC, MK, MT, NL, NO, PL, PT, RO, RS, SE, SI, SK, SM, TR), OAPI (BF, BJ, CF, CG, CI, CM, GA, GN, GQ, GW, ML, MR, NE, SN, TD, TG).

Published:

— with international search report (Art. 21(3))

(54) Title: INDUCTION VOLTAGE ELECTRICAL PRECIPITATOR HAVING HONEYCOMB ELECTRIC CHARGE PART

[Fig. 3]

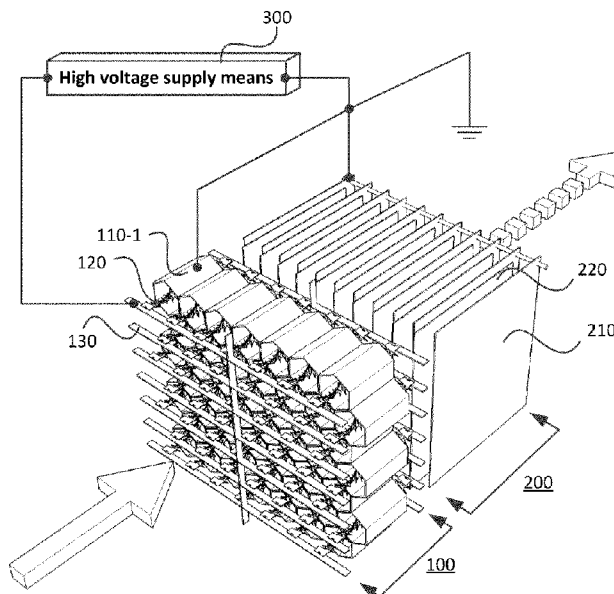

(57) Abstract: An induction voltage electrical precipitator having a honeycomb charging part of the present invention is disclosed. The conventional induction voltage electrical precipitator has a dust collecting efficiency of about 95% to 96% in terms of dust collecting performance when it is driven at 15,000 volts. However, it is difficult to obtain a higher dust collecting efficiency than this due to a structural problem and a constant dust collecting efficiency cannot be obtained at a portion where the flow is fast or a portion where the flow change is rapid. The induction voltage electrical precipitator having a honeycomb charging part of the present invention is characterized in that charging regions with a predetermined length are formed in an air flow direction by virtue of the honeycomb charging part having spin-ionizers disposed in parallel with the air flow to sufficiently charge targets to be collected and thus relatively increase the dust collecting efficiency, and also in that primary dust collection is performed in the honeycomb electric charge part and secondary dust collection is performed in the dust collecting part to relatively increase the dust collecting efficiency. The honeycomb electric charge part having a relatively longer charging interval than the conventional electrical precipitator using an induction voltage in-

creases the dust collecting efficiency by 99% or more under the same condition of applying 15,000 volts. In addition, the relatively high dust collecting efficiency is not decreased even at a portion where the flow is fast or a portion where the flow change is rapid, and the dust collecting efficiency is relatively increased by performing primary dust collection in the honeycomb electric charge part and then secondary dust collection in the dust collecting part.



## Description

### **Title of Invention: INDUCTION VOLTAGE ELECTRICAL PRECIPITATOR HAVING HONEYCOMB ELECTRIC CHARGE PART**

#### **Technical Field**

- [1] The present invention relates to an electrical precipitator including an electric charge part and a dust collecting part in which dust particles are electrically charged by the corona discharge in the electric charge part and charged dust particles are moved and collected to the dust collecting part by the Coulomb force, and more particularly, relates to an electrical precipitator in which the dust collecting part is grounded and dust is collected by an induced voltage.

[2]

#### **Background Art**

- [3] To briefly explain a principle of electrical precipitation of the electrical precipitator shown in FIG. 1, targets contained in the polluted air such as dust, motes and moisture particles to be collected are electrically charged, and Coulomb force (i.e., electrostatic force) is applied to the targets in the direction of dust collecting plates to collect the charged particles.
- [4] In the electrical precipitator using the principle mentioned above, a high voltage is typically applied to the discharging electrode to form an electric field, and then electric charges are generated and moved around the discharging electrode by the corona discharge which is a phenomenon in which the electrode having the stronger electric field among two electrodes has conductivity due to a high voltage, so that dust or the like is electrically charged. The charged dust is affected by the Coulomb force generated in the direction of the dust collecting electrode within the electric field, and is moved to the dust collecting electrode by the Coulomb force and collected on the surface of the dust collecting electrode.
- [5] The electrical precipitator using the principle described above typically includes a single-stage type and a dual-stage type, and the single-stage type precipitator is called a Cottrell electrical precipitator that integrates the discharging part and the dust collecting part as one body and is most usually employed as means for preventing air pollution.
- [6] The Cottrell precipitator typically operates at a voltage between 30 kV and 100 kV and is installed in large-scale industrial plants. In addition, because of the Cottrell precipitator's simple structure and excellent dust collecting performance, it is widely used as an industrial device that prevents dust such as liquid-state and solid-state particles

generated in various industrial plants from being emitted.

- [7] The Cottrell precipitator is effective at preventing reentrainment but cannot easily suppress deionization because electricity is repetitively applied to collect the dust particles. In addition, a high voltage should be applied to the dust collecting electrode, and the dust collecting ability may be lost when discharge takes place in the dust collecting electrode.
- [8] In addition, when the dust particles are collected up to about 8 mm to 12.7 mm in the dust collecting electrode, the dust particles should be rapped continuously to maintain the dust collecting ability. Thus, the Cottrell precipitator needs to have a sprinkler or a device for applying a mechanical impact or vibration.
- [9] When the dust particles are not rapped, the deionization occurs and the charged dust particles are neutralized, so that the dust collecting performance is significantly degraded and the collected dust particles are neutralized and reentrained.
- [10] The dual-stage precipitator includes the separate discharging part and dust collecting part. The dual-stage precipitator generates the electric field by the voltage difference between the discharging electrode of the discharging part and the dust collecting electrode of the dust collecting part, and pulls and collects the charged dust particles to the dust collecting electrode of the dust collecting part when the dust particles charged through the discharging part flow into the electric field.
- [11] Because the discharging part and the dust collecting part are separate in the dual-stage precipitator, the dual-stage precipitator is usually used in an air cleaning process having a relatively low dust density. The dual-stage precipitator does not undergo deionization, but it discharges the reentrained dust particles as is and also has a relatively complicated structure.
- [12] To cope with the problems associated with the single-stage and dual-stage precipitators mentioned above, an "Electrostatic Precipitator Using Induction Voltage" has been proposed in Korean Patent Application No. 10-2005-0127542, which explains the configuration and basic principle of the electrostatic precipitator using an induction voltage as shown in FIG. 2.
- [13] As shown in FIG. 2, a projective type discharging electrode 10 is connected to a power source and is supplied with charges at a high DC voltage of not less than 11,000 volts, and the charges applied with such a high voltage are charged at projecting portions of the projective type discharging electrode 10 and then discharged by the corona discharge phenomenon to form a charging region A2.
- [14] Targets 1 such as dust, motes and moisture particles contained in the externally polluted air are in an electrically neutral state, and when the targets 1 of the electrically neutral state enter the charging region A2, the particles of the electrically neutral state are changed to charged targets 2 of the electrically negative state by the impact or ab-

sorption with anionic gas molecules.

[15] According to the electrostatic precipitator of the related art mentioned above, the electrostatic precipitator further includes an induction voltage plate 20, which grounds the dust collecting electrode 30, is disposed independently without electrical connection and causes a voltage to be induced by the projective type discharging electrode 10. The induction voltage plate is disposed between the projective type discharging electrode 10 and the dust collecting electrode 30 to generate an electrostatic field, and an attractive force is applied to the charged dust pulled to the grounded dust collecting electrode 30 by the Coulomb force to increase the dust collecting ability.

[16] In addition, the conventional discharging electrode of the wire type is substituted with the projective type discharging electrode 10 of the saw form to increase a mechanical strength. The dust collecting electrode 30 is grounded to neutralize the charged dust attached to the dust collecting electrode 30 at the time of attachment, so that the neutralized dust 3 is detached from the dust collecting electrode 30 by gravity. Therefore, it is possible to remove dust attached to the dust collecting electrode by gravity without separate means for removing the dust attached to the dust collecting electrode 30, maintenance is easy, assembly is also easy by virtue of the simplified structure of the electric filter of the electrostatic precipitator, and the manufacturing cost of the electrostatic precipitator can be saved.

[17] The electrostatic precipitator using the induction voltage mentioned above has an advantage in that the problems described above are improved over the single-type and dual-type electrical precipitators and shows a dust collecting efficiency of about 95 to 96% in terms of dust collecting performance when it is driven at 15,000 volts. However, it is difficult to obtain a higher efficiency than this due to a structural problem.

[18] In particular, when the projective type discharging electrode 10 is formed vertically in terms of the direction of air flow to have a narrowed portion with a relatively small width of the charging region where the air flow is fast or a portion where the air flow changes rapidly as shown in FIG. 2, charging is not sufficiently performed on the targets to be collected due to the small width of the charging region, and thus the dust collecting efficiency may be decreased.

[19]

## **Disclosure of Invention**

### **Technical Problem**

[20] The present invention is directed to an electrical precipitator using an induction voltage with a relatively improved dust collecting efficiency under the same conditions as the conventional electrical precipitator using the induction voltage, and more par-

ticularly, is directed to an electrical precipitator having a dust collecting efficiency that is not decreased even at a portion where the air flow is fast or a portion where the air flow changes rapidly.

[21]

### **Solution to Problem**

[22]

One aspect of the present invention provides an induction electrical precipitator using a honeycomb electric charge part. The electrical precipitator using an induction voltage includes: a honeycomb electric charge part including: a charging subassembly having a plurality of charging dust collection subtubes, the charging dust collection subtubes being formed of a metal material having a hexagonal tube shape, being disposed in parallel with the direction in which polluted air flows, and being electrically grounded and connected in parallel; spin-ionizers, each of the spin-ionizers being formed as a metal plate relatively longer than each of the charging dust collection subtubes, having a plurality of protrusions at both edges of a longitudinal direction, connection portions at both ends, and a twisted structure for providing a centrifugal force to targets to be collected, and being inserted into the respective charging dust collection subtube and disposed at a central portion of the charging dust collection subtube; and power supply supports disposed at front and rear stages of the charging dust collection subtubes, and connected to the connection portions of the spin-ionizers to fix the spin-ionizers and electrically connect the spin-ionizers to power supply means; a dust collecting part including: a plurality of dust collecting electrode plates formed of a metal material having a plate shape, being electrically grounded and disposed in parallel with the direction in which the air flows; and a plurality of induction voltage plates formed of a metal material having a plate shape, each of the induction voltage plates being disposed between the dust collecting electrode plates, protruding toward the honeycomb electric charge part compared to the dust collecting electrode plates, and generating a voltage induced by the honeycomb electric charge part without electrical connection; a carrier included inside the honeycomb electric charge part and the dust collecting part and forming an exterior shape of the electrical precipitator; and high voltage supplying means electrically connected to the power supply supports for supplying the spin-ionizers of the honeycomb electric charge part with a high voltage.

[23]

In addition, each of the spin-ionizers of the honeycomb electric charge part has a plurality of lateral protrusions at both sides in a longitudinal direction.

[24]

In addition, each of the spin-ionizers has a width  $1/3$  to  $1/2$  times a diameter of each of the charging dust collection subtubes for generating an eddy current, and has a height of the protrusion  $1/10$  to  $1/8$  times the diameter of each of the charging dust collection subtubes.

[25] In addition, the charging dust collection subtubes of the honeycomb electric charge part finish the exterior of the precipitator using a nonflammable silicon based material having a predetermined thickness that surrounds and insulates the exterior and also maintains the assembled state of the precipitator.

[26] In addition, the precipitator further includes a dust collecting container that is in downward communication with a bottom of the carrier where the dust collecting part is located and collecting dust that is collected in the dust collecting part and falls from the dust collecting part due to gravity.

[27]

### **Advantageous Effects of Invention**

[28] According to the induction voltage electrical precipitator using a honeycomb electric charge part of the present invention, it is possible to exhaust dust with a relatively high dust collecting concentration as is possible with the conventional precipitator. In addition, a mechanical strength of the discharging electrode itself is high, a simplified structure having independent induction voltage plates and grounded dust collecting plates without electrical connections is realized, and maintenance is easy because separate dust removing means for removing dust attached to the dust collecting electrode plate such as a cleaning device or rapping device is not required. In addition, an electric filter structure of the electrical precipitator is simplified to facilitate the assembly and save the manufacturing cost of the electrical precipitator. In addition, the relatively high dust collecting efficiency is not decreased by virtue of the honeycomb electric charge part having a relatively long charging interval even at a portion where the flow is fast or a portion where the flow change is rapid. In addition, the dust collecting efficiency is relatively increased by performing primary dust collection in the honeycomb electric charge part and then secondary dust collection in the dust collecting part.

[29]

### **Brief Description of Drawings**

[30] The above and other features and advantages of the present invention will become more apparent to those of ordinary skill in the art by describing in detail exemplary embodiments thereof with reference to the attached drawings in which:

[31] FIG. 1 is a view illustrating a basic principle of an electrical precipitator;

[32] FIG. 2 is a view illustrating a configuration and a basic principle of a conventional electrical precipitator using an induction voltage;

[33] FIG. 3 is a view illustrating an induction voltage electrical precipitator having a honeycomb electric charge part according to the present invention;

[34] FIG. 4 is a view illustrating a honeycomb electric charge part of an induction voltage

electrical precipitator according to the present invention;

[35] FIG. 5 is a view illustrating a charging subassembly of an induction voltage electrical precipitator having a honeycomb electric charge part according to the present invention;

[36] FIG. 6 is a view illustrating an insulating layer of a charging subassembly of an induction voltage electrical precipitator having a honeycomb electric charge part according to the present invention;

[37] FIG. 7 is a view illustrating spin-ionizers of an induction voltage electrical precipitator having a honeycomb electric charge part according to the present invention;

[38] FIG. 8 is a view illustrating a connection structure of a spin-ionizer of an induction voltage electrical precipitator having a honeycomb electric charge part according to the present invention; and

[39] FIG. 9 is a view illustrating a carrier of an induction voltage electrical precipitator having a honeycomb electric charge part according to the present invention.

[40]

### **Mode for the Invention**

[41] Detailed description of the present invention will be given with reference to accompanying drawings which illustrate by way of example specific embodiments as which the present invention can be realized. These embodiments are described in sufficient detail that those skilled in the art can realize the present invention. It should be understood that various embodiments of the present invention may be different but need not be mutually exclusive from each other. For example, specific shapes, structures and features described herein in association with an embodiment may be realized in other embodiments without departing from the technical spirit and scope of the present invention. In addition, it should be understood that positions or locations of individual components in respective embodiments may be changed without departing from the technical spirit and scope of the present invention. Therefore, the following detailed description is not intended to be taken as limited meaning, and the scope of the present invention is limited only by the accompanying claims and all claims equivalent to the accompanying claims. In the drawings, like numbers refer to the same or like functions throughout the specification.

[42] The present invention will be described more fully hereinafter with reference to the accompanying drawings in order for those skilled in the art to easily realize the present invention.

[43] The induction voltage electrical precipitator having a honeycomb electric charge part of the present invention includes a honeycomb electric charge part 100 and a dust collecting part 200, the honeycomb electric charge part 100 includes a charging sub-

assembly 110-1, spin-ionizers 120 and power supply supports 130, and the dust collecting part 200 includes dust collecting electrode plates 210 and induction voltage plates 220 as shown in FIG. 3 illustrating the induction voltage electrical precipitator having the honeycomb electric charge part of the present invention. The honeycomb electric charge part 100 is disposed at a front stage in terms of the direction in which polluted air enters, and the dust collecting part 200 includes a plurality of dust collecting electrode plates 210 each formed of a metal material having a plate shape and disposed in parallel with the direction in which the air flows, and a plurality of induction voltage plates 220 each formed of a metal material having a plate shape, disposed between the dust collecting electrode plates 210, protruding toward the honeycomb electric charge part 100 compared to the dust collecting electrode plates 210, and generating a voltage induced by the honeycomb electric charge part 100 without electrical connection.

[44] The dust collecting part 200 is disposed serially at a rear stage of the honeycomb electric charge part 100 and is electrically connected to a high voltage supplying means 300 as shown in FIG. 3. The dust collecting part 200 is charged with a high voltage by the honeycomb electric charge part 100 to cause a negative induction voltage, and both grounded dust collecting electrode plates 210 are positively charged by electrostatic induction and electrostatic discharge.

[45] Accordingly, an electric field is generated between each of the induction voltage plates 220 and each of the dust collecting electrode plates 210, charged targets to be collected which enter the electric field are attracted by the dust collecting electrode plate 210 and are repelled by the induction voltage plate 220 to be attached to the dust collecting electrode plate 210. Here, the attraction and repulsion forces are generated by Coulomb's law, description whereof is omitted.

[46] Accordingly, the targets contained in the polluted air are sufficiently charged by the spin-ionizers 120 that are formed with a predetermined length in parallel with the air flow and generate corona discharge while passing through the honeycomb electric charge part 100. Some charged targets are collected in the honeycomb electric charge part 100, and the charged targets that have passed through the honeycomb electric charge part 100 are collected in the dust collecting electrode plates 210 while passing through the dust collecting part 200 consisting of the dust collecting electrode plates 210 and the induction voltage plates 220.

[47] That is, the charged targets are primarily collected in the charging subassembly 110-1 of the honeycomb electric charge part 100 and the rest are secondarily collected in the dust collecting part 200. As a result, both the honeycomb electric charge part 100 and the dust collecting part 200 perform the dust collection in accordance with the present invention.

- [48] The honeycomb electric charge part 100 and the dust collecting part 200 are electrically connected to the high voltage supplying means 300 as shown in FIG. 3, and are disposed within the carrier 400 having a structure that forms an exterior shape of the precipitator of the present invention and can be inserted into a venting pipe or exhausting pipe as shown in FIG. 9, which illustrates the carrier of the induction voltage electrical precipitator having the honeycomb electric charge part according to the present invention.
- [49] The dust collecting container 500 is in downward communication with a bottom of the carrier 400 in which the dust collecting part 200 is located, and is connected to the communication portion 410 of the carrier 400 so that the dust collected in the dust collecting part 200 falls due to gravity and is stored in the dust collecting container 500.
- [50] The dust collecting container 500 may have various shapes and structures, and has a structure that allows the dust collecting container to be connected to or disconnected from the carrier 400 as means for communicating with the inside of the carrier 400 and storing the targets to be collected such as dust.
- [51] Hereinafter, an essential component of the present invention, that is, the honeycomb electric charge part 100, will be described in detail. The honeycomb electric charge part 100 provides a charging interval in parallel with the air flow to perform sufficient charging on the targets to be collected, and some dust collection is performed on the charging interval.
- [52] As shown in FIG. 4 illustrating the honeycomb electric charge part of the induction voltage electrical precipitator according to the present invention, the honeycomb electric charge part 100 includes the charging subassembly 110-1 where a plurality of charging dust collection subtubes 110 are assembled in a planar way, spin-ionizers 120 inserted into respective charging dust collection subtubes 110 and generating corona discharge to form charged regions, and power supply supports 130 supplying a power to the spin-ionizers 120 while fixing the spin-ionizers.
- [53] Accordingly, the charging interval in parallel with the air flow, that is, a horizontal charging interval, is provided instead of the conventional vertical charging interval, and some charged targets are collected through the grounded charging dust collection subtubes 110.
- [54] As shown in FIG. 5, which illustrates a charging subassembly of the induction voltage electrical precipitator having the honeycomb electric charge part according to the present invention, the charging subassembly 110-1 is assembled by the charging dust collection subtubes 110, which are formed of a metal material with a high electric conductivity such as aluminum, have a predetermined length L, are disposed in parallel with the direction in which the polluted air flows, and are electrically grounded. That

is, the charging dust collection subtubes 110 are connected and assembled in a planar way as shown in FIG. 5.

[55] The length L of the charging dust collection subtube 100 is not specifically limited. However, when the length L of the charging dust collection subtube 100 is increased, a dust collecting performance is relatively enhanced whereas energy consumption is increased, so that the length L of the charging dust collection subtube 100 is determined by conditions including a dust concentration or an air flow in an environment where the electrical precipitator of the present invention is installed.

[56] In addition, the charging subassembly 110-1 has an insulating layer 140 with a predetermined thickness, which is formed of a nonflammable silicon based material for surrounding and insulating the exterior of the charging subassembly while maintaining the assembled state as shown in FIG. 5.

[57] As shown in FIG. 6, illustrating the insulating layer of the charging subassembly of the induction voltage electrical precipitator having a honeycomb electric charge part according to the present invention, the insulating layer 140 acts to fill an empty space generated between the outside of the charging subassembly 110-1 and the carrier 400 due to the hexagonal tube shape while insulating the grounded charging subassembly 110-1 and maintaining the assembled state.

[58] As shown in FIGS. 4 and 7, illustrating the spin-ionizers of the induction voltage electrical precipitator having the honeycomb electric charge part of the present invention, each of the spin-ionizers 120 is a metal plate relatively longer than each of the charging dust collection subtubes 110, has a plurality of protrusions 122 at both edges in a longitudinal direction, has the connection portions 126 at both ends, and has a twisted structure for applying a centrifugal force to the targets to be collected so that it is inserted into the respective charging dust collection subtube 110 and is disposed at a central portion.

[59] The spin-ionizers 120 may be disposed at the central portion of the charging dust collection subtubes 110 by connecting the spin-ionizers 120 between the two fixed power supply supports 130, and are electrically connected to the high voltage supplying means 300 through the power supply supports 130 as shown in FIG. 8, which illustrates a connection structure of the spin-ionizers of an induction voltage electrical precipitator having a honeycomb electric charge part according to the present invention.

[60] As shown in FIG. 7, the spin-ionizers 120 may further include a plurality of lateral protrusions 124 at both sides in a longitudinal direction. The lateral protrusions 124 relatively increase corona and charging regions by relatively increasing the number of protrusions where the corona discharge occurs, so that charging of the targets to be collected may be more smoothly performed.

[61] Each of the spin-ionizers 120 has a width  $1/3$  to  $1/2$  times a diameter of the charging dust collection subtube 110 and has a height  $1/10$  to  $1/8$  times the diameter of the charging dust collection subtube 110 for generating an eddy current.

[62] In the drawings and specification, there have been disclosed typical exemplary embodiments of the invention and, although specific terms are employed, they are used in a generic and descriptive sense only and not for purposes of limitation. As for the scope of the invention, it is to be set forth in the following claims. Therefore, it should be understood by those of ordinary skill in the art that various changes in form and details may be made therein without departing from the spirit and scope of the present invention as defined by the following claims.

[63]

## Claims

[Claim 1]

An electrical precipitator using an induction voltage, comprising:  
a honeycomb electric charge part including:  
a charging subassembly having a plurality of charging dust collection subtubes, the charging dust collection subtubes being formed of a metal material having a hexagonal tube shape, being disposed in parallel with the direction in which polluted air flows, and being electrically grounded and connected in parallel;  
spin-ionizers, each of the spin-ionizers being formed as a metal plate relatively longer than each of the charging dust collection subtubes, having a plurality of protrusions at both edges of a longitudinal direction, connection portions at both ends, and a twisted structure for providing a centrifugal force to targets to be collected, and being inserted into the respective charging dust collection subtube and disposed at a central portion of the charging dust collection subtube;  
and  
power supply supports disposed at front and rear stages of the charging dust collection subtubes, and connected to the connection portions of the spin-ionizers to fix the spin-ionizers and electrically connect the spin-ionizers to power supply means;  
a dust collecting part including:  
a plurality of dust collecting electrode plates formed of a metal material having a plate shape, being electrically grounded and disposed in parallel with the direction in which the air flows; and  
a plurality of induction voltage plates formed of a metal material having a plate shape, each of the induction voltage plates being disposed between the dust collecting electrode plates, protruding toward the honeycomb electric charge part compared to the dust collecting electrode plates, and generating a voltage induced by the honeycomb electric charge part without electrical connection;  
a carrier included inside the honeycomb electric charge part and the dust collecting part and forming an exterior shape of the electrical precipitator; and  
high voltage supplying means electrically connected to the power supply supports for supplying the spin-ionizers of the honeycomb electric charge part with a high voltage,  
wherein each of the spin-ionizers of the honeycomb electric charge part

has a plurality of lateral protrusions at both sides in a longitudinal direction.

[Claim 2] The precipitator of claim 1, wherein each of the spin-ionizers has a width  $1/3$  to  $1/2$  times a diameter of each of the charging dust collection subtubes for generating an eddy current, and has a height of the protrusion  $1/10$  to  $1/8$  times the diameter of each of the charging dust collection subtubes.

[Claim 3] The precipitator of claim 1, wherein the charging dust collection subtubes of the honeycomb electric charge part finish the exterior of the precipitator using a nonflammable silicon based material having a pre-determined thickness that surrounds and insulates the exterior and also maintains the assembled state of the precipitator.

[Claim 4] The precipitator of claim 1, further comprising:  
a dust collecting container in downward communication with a bottom of the carrier where the dust collecting part is located, and collecting dust that is collected in the dust collecting part and falls from the dust collecting part due to gravity.

[Fig. 1]

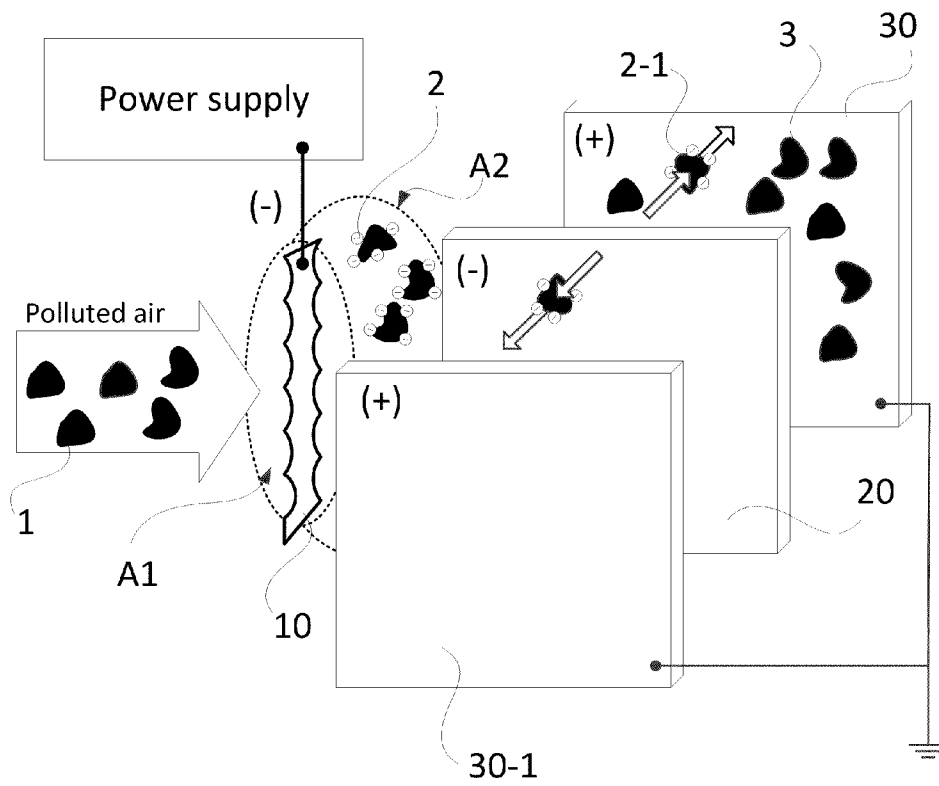

[Fig. 2]

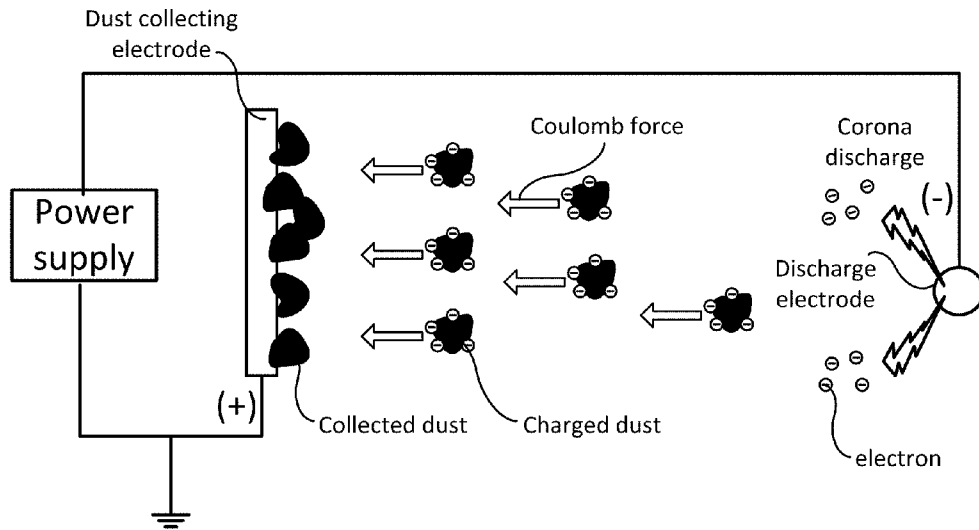

[Fig. 3]

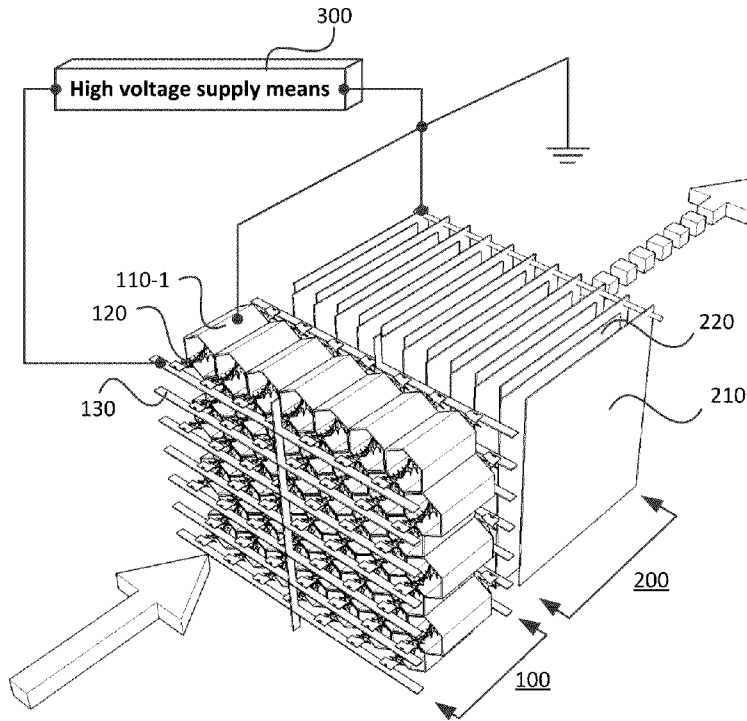

[Fig. 4]

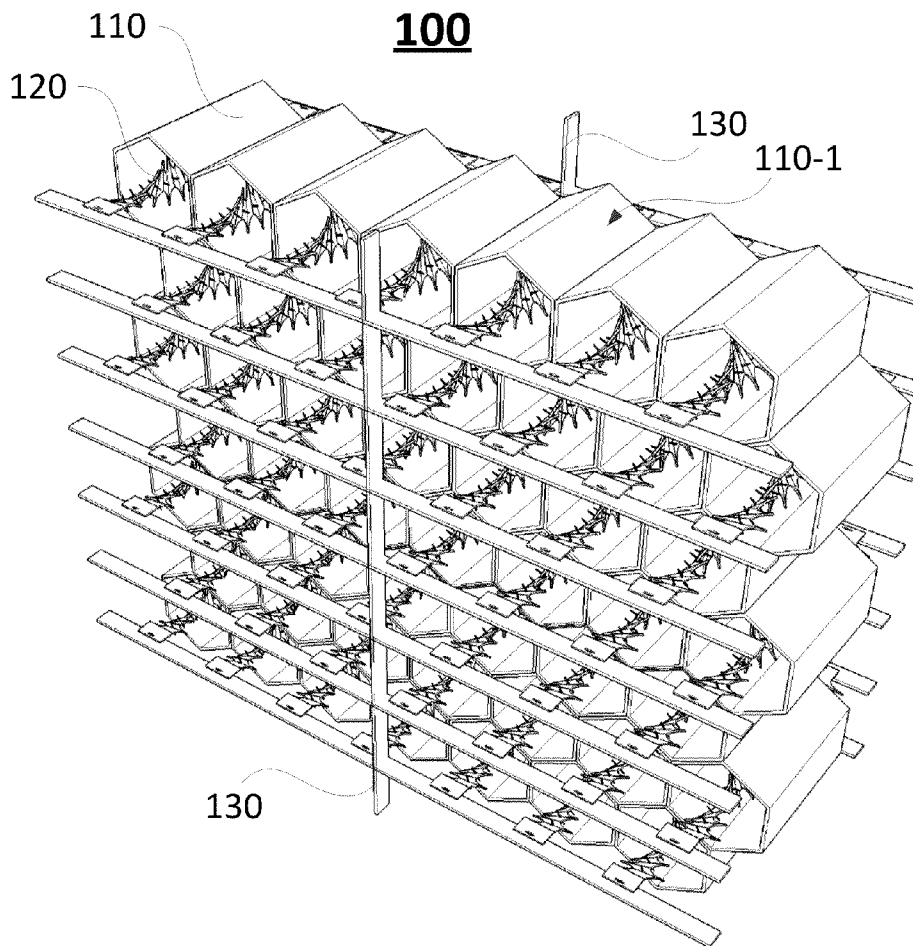

[Fig. 5]

110

**110-1**

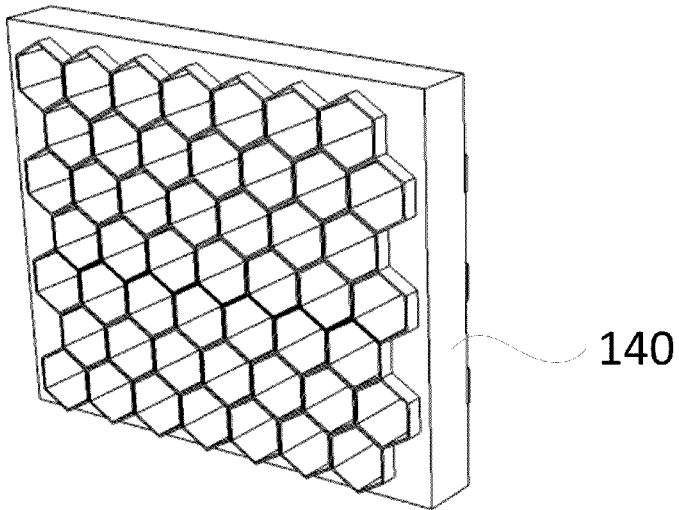
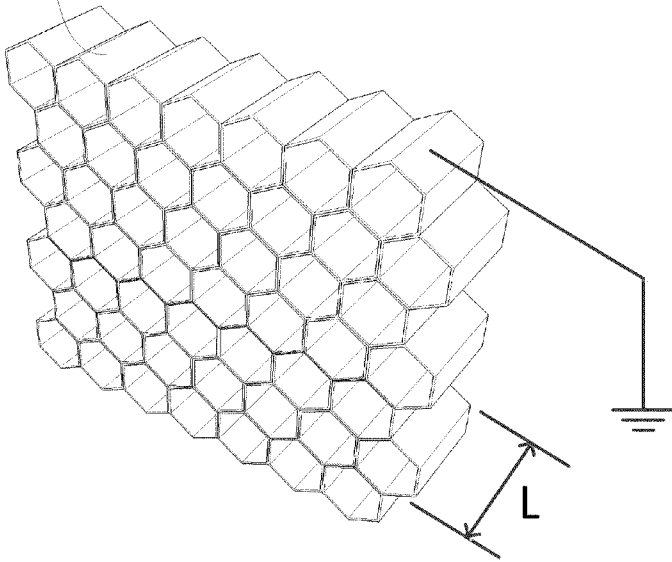

[Fig. 6]

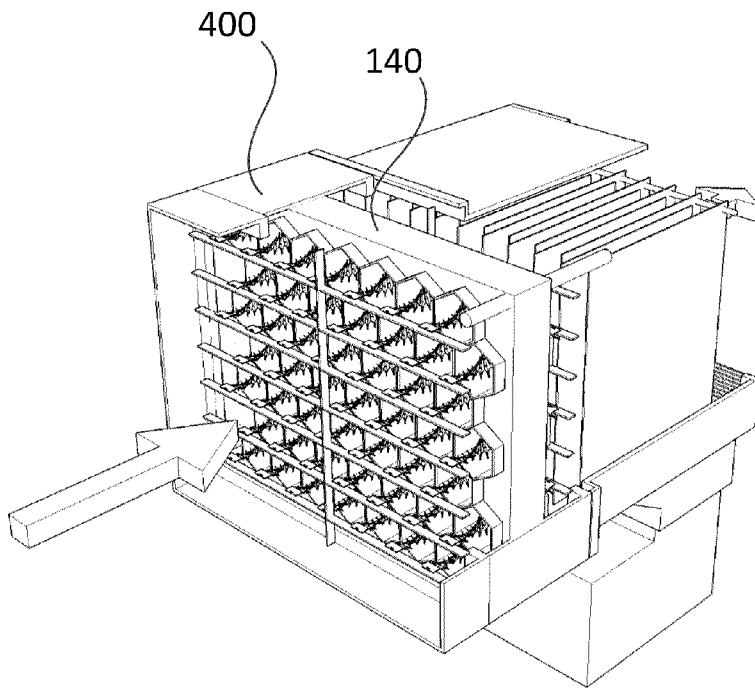

[Fig. 7]

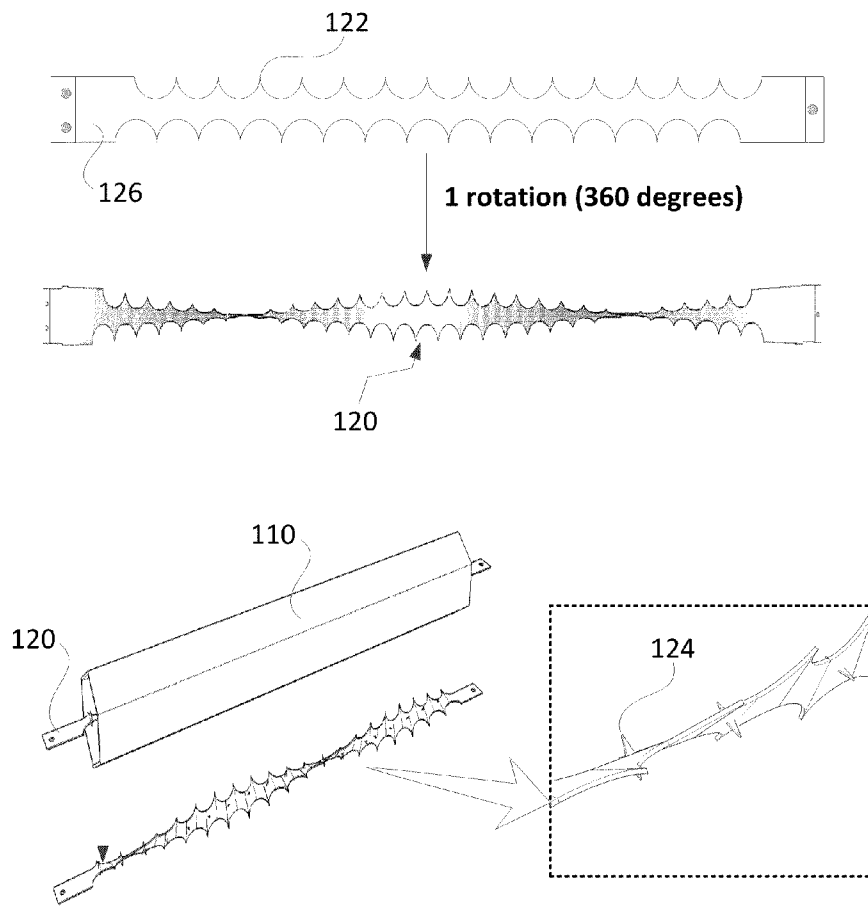

[Fig. 8]

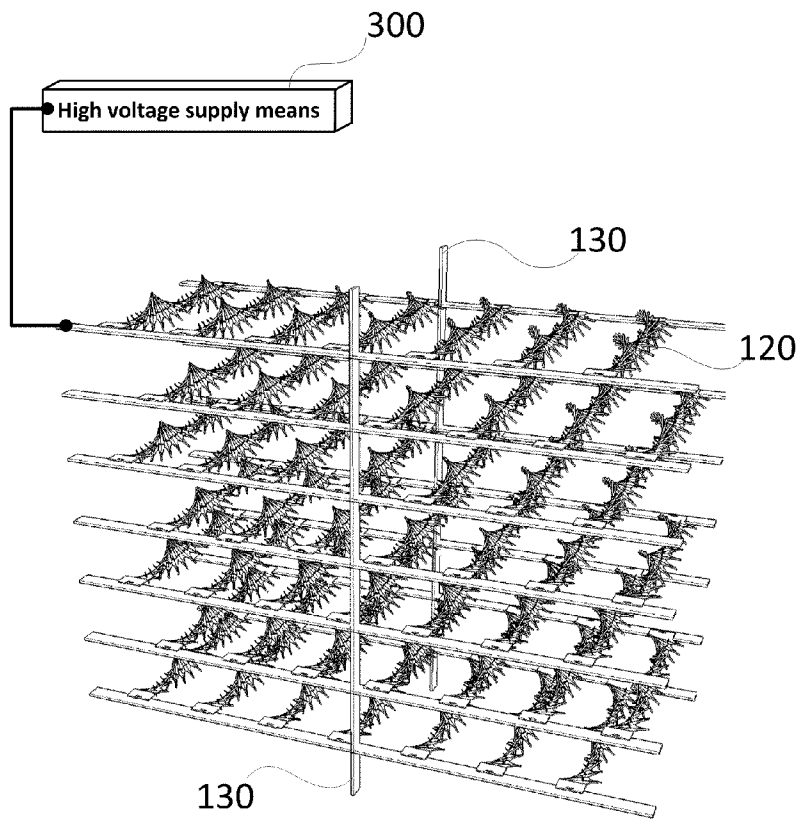

[Fig. 9]

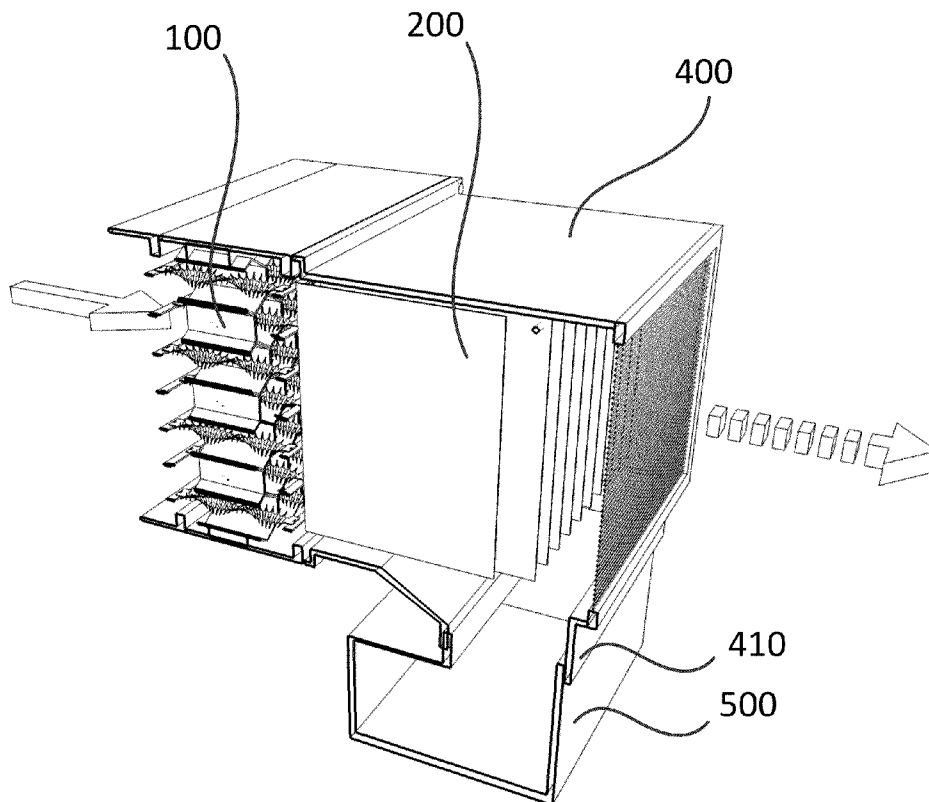

**A. CLASSIFICATION OF SUBJECT MATTER*****B03C 3/38(2006.01)i, B03C 3/12(2006.01)i, B03C 3/40(2006.01)i***

According to International Patent Classification (IPC) or to both national classification and IPC

**B. FIELDS SEARCHED**

Minimum documentation searched (classification system followed by classification symbols)

B03C 3/38; B03C 3/36; B03C 3/78; B03C 3/40; B03C 3/00; B03C 3/41

Documentation searched other than minimum documentation to the extent that such documents are included in the fields searched

Korean utility models and applications for utility models

Japanese utility models and applications for utility models

Electronic data base consulted during the international search (name of data base and, where practicable, search terms used)

eKOMPASS(KIPO internal) &amp; Keywords: electrical precipitator, honeycomb electric charge part, spin-ionizer, power supply support, dust collecting part

**C. DOCUMENTS CONSIDERED TO BE RELEVANT**

Category*	Citation of document, with indication, where appropriate, of the relevant passages	Relevant to claim No.
PX	KR 10-2011-0133081 A (Royal Ind. Tech. Corp. et al.) 12 December 2011. See paragraphs [0030]-[0049] and figures 3-9.	1-4
A	KR 10-0724556 B1 (Royal Ind. Tech. Corp.) 11 June 2007. See the entire document.	1-4
A	KR 10-0817595 B1 (Royal Ind. Tech. Corp.) 27 March 2008. See the entire document.	1-4
A	US 05254155 A (Fred E. Mensi) 19 October 1993. See the entire document.	1-4
A	KR 20-0133366 Y1 (Bo Yang Mech. Eng. Co., Ltd.) 15 January 1999. See the entire document.	1-4

 Further documents are listed in the continuation of Box C. See patent family annex.

\* Special categories of cited documents:

"A" document defining the general state of the art which is not considered to be of particular relevance

"E" earlier application or patent but published on or after the international filing date

"L" document which may throw doubts on priority claim(s) or which is cited to establish the publication date of citation or other special reason (as specified)

"O" document referring to an oral disclosure, use, exhibition or other means

"P" document published prior to the international filing date but later than the priority date claimed

"T" later document published after the international filing date or priority date and not in conflict with the application but cited to understand the principle or theory underlying the invention

"X" document of particular relevance; the claimed invention cannot be considered novel or cannot be considered to involve an inventive step when the document is taken alone

"Y" document of particular relevance; the claimed invention cannot be considered to involve an inventive step when the document is combined with one or more other such documents, such combination being obvious to a person skilled in the art

"&amp;" document member of the same patent family

Date of the actual completion of the international search

05 SEPTEMBER 2012 (05.09.2012)

Date of mailing of the international search report

**07 SEPTEMBER 2012 (07.09.2012)**

Name and mailing address of the ISA/KR

Korean Intellectual Property Office  
189 Cheongsu-ro, Seo-gu, Daejeon Metropolitan  
City, 302-701, Republic of Korea

Facsimile No. 82-42-472-7140

Authorized officer

CHANG, BONG HO

Telephone No. 82-42-481-3353



**INTERNATIONAL SEARCH REPORT**

Information on patent family members

International application No.

**PCT/KR2012/001033**

Patent document cited in search report	Publication date	Patent family member(s)	Publication date
KR 10-2011-0133081 A	12.12.2011	None	
KR 10-0724556 B1	11.06.2007	WO 2007-073020 A1	28.06.2007
KR 10-0817595 B1	27.03.2008	None	
US 05254155 A	19.10.1993	None	
KR 20-0133366 Y1	15.01.1999	None	