



(51) International Patent Classification:

G01G 11/08 (2006.01) B41J 2/175 (2006.01)
G01G 17/06 (2006.01)

(21) International Application Number:

PCT/EP2013/060302

(22) International Filing Date:

17 May 2013 (17.05.2013)

(25) Filing Language:

English

(26) Publication Language:

English

(30) Priority Data:

61/720,080 30 October 2012 (30.10.2012) US

(71) Applicant: SICPA HOLDING SA [CH/CH]; Avenue de Florissant 41, CH-1008 Prilly (CH).

(72) Inventors: BRAISSANT, Marc; Chemin de Floreyres 3, CH-1405 Pomy (CH). RAEMY, Xavier Cédric; Route d'Arnier 40, CH-1092 Belmont-sur-Lausanne (CH). DUCA, Nicola; Chemin des Semilles 25 D, CH-1870 Monthey (CH). BONDALLAZ, Carine; Rue du Petit Beaulieu 9, CH-1004 Lausanne (CH). GUERITAUULT, Thomas; Chemin de Bel-Orne 8, CH-1008 Prilly (CH).

(74) Agents: BECHER, Claus, Thomas et al.; Hoffmann · Eitle, Arabellastrasse 4, 81925 Munich (DE).

(81) Designated States (unless otherwise indicated, for every

kind of national protection available): AE, AG, AL, AM, AO, AT, AU, AZ, BA, BB, BG, BH, BN, BR, BW, BY, BZ, CA, CH, CL, CN, CO, CR, CU, CZ, DE, DK, DM, DO, DZ, EC, EE, EG, ES, FI, GB, GD, GE, GH, GM, GT, HN, HR, HU, ID, IL, IN, IS, JP, KE, KG, KM, KN, KP, KR, KZ, LA, LC, LK, LR, LS, LT, LU, LY, MA, MD, ME, MG, MK, MN, MW, MX, MY, MZ, NA, NG, NI, NO, NZ, OM, PA, PE, PG, PH, PL, PT, QA, RO, RS, RU, RW, SC, SD, SE, SG, SK, SL, SM, ST, SV, SY, TH, TJ, TM, TN, TR, TT, TZ, UA, UG, US, UZ, VC, VN, ZA, ZM, ZW.

(84) Designated States (unless otherwise indicated, for every

kind of regional protection available): ARIPO (BW, GH, GM, KE, LR, LS, MW, MZ, NA, RW, SD, SL, SZ, TZ, UG, ZM, ZW), Eurasian (AM, AZ, BY, KG, KZ, RU, TJ, TM), European (AL, AT, BE, BG, CH, CY, CZ, DE, DK, EE, ES, FI, FR, GB, GR, HR, HU, IE, IS, IT, LT, LU, LV, MC, MK, MT, NL, NO, PL, PT, RO, RS, SE, SI, SK, SM, TR), OAPI (BF, BJ, CF, CG, CI, CM, GA, GN, GQ, GW, ML, MR, NE, SN, TD, TG).

Published:

— with international search report (Art. 21(3))

(54) Title: SYSTEM AND METHOD FOR MONITORING WEIGHT OF MATERIAL IN RESERVOIR

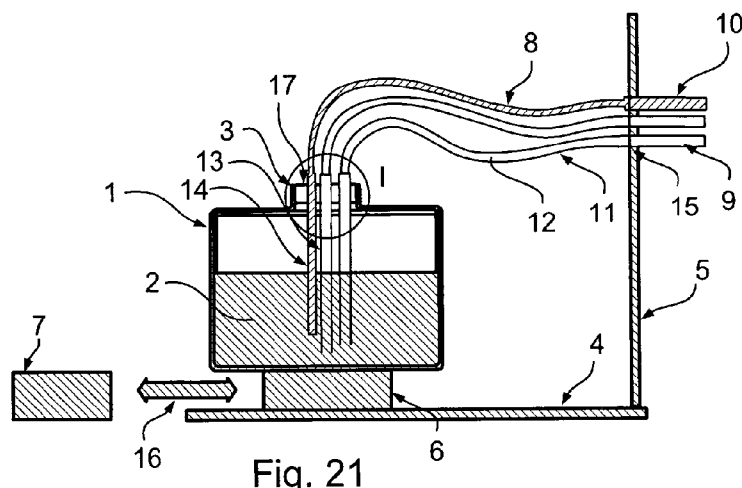

Fig. 21

(57) Abstract: So as to accurately measure the consumption of material from a reservoir to a high degree of precision during dispensing, and when calibration of the measurement device cannot be reliably performed, the invention proposes an apparatus and a method for measuring a quantity of material to be dispensed. The dispensing apparatus has a dispensing unit for dispensing at least part of the material; a reservoir containing the material to be dispensed; connectors between the reservoir and the dispensing unit; a scale under the reservoir, the scale being for connection to a processor for processing electronic signals from the scale and for converting the signals into a weight measurement; and tubes inserted into the reservoir, the tubes carrying material into and from the reservoir, the tubes being inserted into the reservoir by means of one of the following : i. through a flexible membrane surrounding the connectors, ii. with flexible tube sections between the connectors and the dispensing unit, and iii. through a reservoir cap, the cap sliding relative to the reservoir.



**SYSTEM AND METHOD FOR MONITORING WEIGHT
OF MATERIAL IN RESERVOIR**

5 **ABSTRACT:**

The present invention provides a way to monitor using a weight sensor to a high degree of precision the rate of material consumption from a reservoir while in operation by alleviating perturbations due to extraneous forces exerted on the reservoir by the connecting tubes and conduits that carry the material and transmit electrical signals between the reservoir and the other components of the dispensing system.

BACKGROUND:

15 Many types of sensors are known for measuring the height, weight, level or volume of a material (liquid, solid or gas) in a reservoir such as bubble sensors, pressure sensors, differential pressure sensors, radar sensors, ultrasonic sensors, laser interferometric sensors, linear photo sensors, 20 capacitive and conductive probes, plungers, floaters and scales. Many of these sensors cannot easily be used in industrial applications to monitor the rate of consumption of a material being dispensed from a reservoir when a high degree of precision is required because sensors of the required accuracy may be too expensive, too complicated or too fragile 25 to use in the required applications.

For example, it may be desired to monitor the consumption of 1 kg of material contained in a reservoir to a precision of 30 ± 1 gram. If the consumption is monitored by measuring the level of material, the change in level will depend on the reservoir shape and could be maximized by making a very tall reservoir with a narrow cross-section. However this is not always possible due to space constraints for the equipment in

the factory. In many cases the reservoir has a small compact shape and a 1 gram change in the quantity of material typically correspond to a change of 0.05 mm or less in the level of material in the reservoir. Measuring such a small
5 change in level may require a very sophisticated and expensive level meter. Additionally, measuring the height or level of material is also vulnerable to a number of other issues: the surface of the liquid may not be flat, and at least three points should be measured (to determine the plane) in case the
10 reservoir is inclined. Furthermore, if the liquid contains chemical agents, it may be necessary to protect the sensor from contact with the chemical to avoid damage or corrosion of the sensing apparatus.

15 Another type of sensor known to measure the amount of material in a reservoir is a strain meter or scale. This solution has the advantage of placing the sensor outside the reservoir, hence protected from the contents. Additionally, the measurement is then independent of the shape and
20 orientation of the reservoir or the chemical phase of the material contained therein. One example of this type of scale is a load cell such as Vishay Tedea-Huntleigh, Single Point Aluminum, Model 1022, which is based on the Wheatstone bridge principle. This load cell is a low-cost sensor that can
25 measure a change in strain to a high degree of precision. When this sensor is loaded with a weight, there is a vertical deformation in the sensor. The size of the deformation gives a measure of the weight of the load. Using this load cell, for example, the weight of a reservoir like the one in the
30 previous example could be measured to a precision of ± 0.01 gram if the reservoir were isolated from the rest of the dispensing apparatus.

Use of a load cell to determine the weight of the contents of a reservoir while material is being dispensed from the reservoir is described in US Pat. No. 7,770,448. The solution described therein solves the problem of measuring the usage of chemicals stored in a canister regardless of chemical type or phase, but it has the drawback that a taring function is needed to allow an operator to tare the empty weight of the canister to account for differences in forces acting on the canister from the connectors that may not be present when the canister is filled prior to insertion in the dispensing apparatus.

If the position of the connectors changes during operation or if the operation is interrupted and the reservoir moved or disconnected and reconnected, the forces exerted on the reservoir by the connectors may change and a discontinuity in the continuous measurement will be produced. This discontinuity may be interpreted as an abrupt change in the measured quantity of material that could be an order of magnitude (or more) higher than the smallest change in material consumption that should be measured. If the position of the connectors changed to exert more force on the reservoir, it would be as if material had been suddenly added to the reservoir. If the position of the connectors changed such that less force was exerted on the reservoir, it would be as material has suddenly been removed from the reservoir. In the latter case, an operator monitoring consumption might erroneously think there had been a leak.

For this reason, the invention described in US Pat. No. 7,770,448 includes a manual taring function; however manual retaring requires operator intervention and thus does not solve the problem if changes in the connector positions occur without the operator's knowledge. Furthermore, such

intervention for retaring is tedious and requires stopping the dispensing, which leads to reduced production efficiency. If operating personnel are not attentive, the operation efficiency will be further reduced.

5

In some cases, the material being consumed is highly valuable. Monitoring may be desired to ensure that material is properly accounted for or does not leak during dispensation, either before the reservoir is inserted in the dispensing device, while the device is in operation, and when the device is stopped and the reservoir removed. In this case, it is important to know how much material is left in the reservoir when it is removed from the dispensing equipment.

15 The existing solutions do not provide a way to accurately measure consumption of material from a reservoir to a high degree of precision during dispensing, and when calibration of the measurement device cannot be reliably performed.

20 For these reasons it is necessary to find a solution that allows accurate measurement without requiring manual operating intervention for taring during dispensing operations or while performing maintenance procedures.

25 **DETAILED DESCRIPTION:**

Accurate measurement of the weight of the reservoir will be possible while the dispensing unit is in operation as long as the extraneous forces exerted on the reservoir by the connectors do not vary in amplitude or direction until the dispensing operation is completed. When the connectors are constructed of flexible material, if they are moved or if their position changes within the limits of the elasticity of the length of the tubing, the material will deform in reaction

30

to the external forces, and the change in the force exerted by the tubing on the reservoir will be negligible.

5 However, since the tubing acts as a conduit for transporting the material being dispensed from the reservoir to the other components of the system, the tubing is often rigid or semi-rigid to prevent kinks which could stop the flow of the material and block the dispensing unit. To allow flexibility in removing the reservoir or performing
10 maintenance on the machine, or for cost reasons, the tubing is frequently semi-rigid so it can be easily displaced, but is only partially able to deform in response to a change in position. In this case, to prevent the tubes from exerting a variable force on the reservoir the forces must either be
15 eliminated or rendered constant.

Using a scale of adequate precision, such as a load cell, the quantity of material in the reservoir can be measured to a high degree of precision without influence from external
20 perturbations when implemented in one of the embodiments described below.

In an exemplary embodiment a scale such as a strain meter or load cell is placed under a reservoir containing material
25 to be dispensed. The material may be ink or a solvent and the reservoir may be contained in a printer. The load cell is connected to a processor that filters and processes the electronic signals from the load cell, converting the signals into a weight measurement which is sent to the dispensing
30 application control logic to record the weight during dispensing. The tubes carrying the material being dispensed into and out of the reservoir in the dispensing apparatus (for example printer) are inserted into the reservoir by one of three methods described below, each of which solve the problem

of varying external forces exerted on the reservoir by the connecting tubes. In this way, the recorded weight may be logged by a software application or dispensing control unit controller and optionally displayed to an operator on a screen.

To solve the problem of variation in forces exerted on the reservoir by the connectors between the reservoir and the dispensing unit, the following three solutions are described:

1. Flexible membrane surrounding the connectors (Figures 1-20)
2. Flexible tube sections between the connectors and the dispensing unit (Figures 21-26)
3. Sliding Cap (Figures 27-29)

1. **Flexible membrane surrounding the connectors** (All the numbers in this paragraph refer to Figures 1-20)

The external forces on the material reservoir may be eliminated by placing the connectors (such as tubes, cables, needles etc.) directly into the open mouth of the reservoir, however if the material is subject to evaporation or sublimation or if the reservoir, also called container herein, must remain closed for other reasons, or if the material is hazardous or subject to alteration, such a solution is not feasible. In this case, the opening of the reservoir may be closed with a seal, membrane, film or foil made of a suitable material (for example, Teflon FEP, PFA and TFE; polypropylene PP, polypropylene copolymer PPCO), which may be of low elasticity, into which the tubes are pushed to insert them in the reservoir and allow dispensing or refilling of the material.

Using a seal has the additional advantage of providing tamper-evidence during distribution and warehousing before the reservoir is placed into the dispensing unit. An attempt to remove or insert material into the reservoir will most likely
5 break the seal, which will leave an obvious trace (hole) in the membrane. Figure 1 illustrates a reservoir 1 with a sealed opening 3 and containing a material to be dispensed 2.

The tubes are inserted into the reservoir by pressing them
10 into the membrane as shown in Figure 6. Only one tube is shown for illustration purposes, but in practice several tubes may be inserted through the membrane if different types of materials must be added or removed. One tube may be used for dispensing the material from the reservoir while another may
15 be used for returning unused material into the reservoir. In some applications, it may be necessary to add solvents to the material to maintain a certain viscosity and an additional tube may be required in that case. Other types of connectors may be also inserted into the reservoir through the membrane,
20 such as cables or conduits connected to sensors placed in the reservoir for transmitting data or other signals, such as electrical signals, to and from the sensor and the control unit of the dispensing apparatus.

The membrane 3 is fixed to the mouth of the reservoir by
25 gluing or a method of sealing such as heat or ultrasonic sealing. Figure 3 shows an expanded view of the edge of the membrane 2 attached to the reservoir with a seal 3 across the the sides of the opening. The chosen method of sealing will
30 produce a seal that is strong enough to withstand the force applied when the membrane is perforated by the tubes so that they can be inserted without pulling the seal off the sides of the opening. A tight seal also ensures that the seal does not break if the container is turned upside down. If the material

being dispensed is corrosive, the membrane may be made of a material that is resistant to the corrosive effects of the material contained in the reservoir in order to avoid being weakened or damaged by coming in contact with the material
5 inside. For example, many industrial solvents are known to be damaging to some types of materials typically used as sealing membranes.

The end of the tube may be designed to have a special
10 shape for piercing as shown in Figures 9 and 10 or may be fitted with special cap, for example having a sharp metal point or similar shape, to aid the insertion. When the tube is inserted into the reservoir, the membrane is partially torn allowing the tube to plunge into the material in the
15 container. The opening may have a characteristic pattern, such as the diamond shape shown in Figure 8 where the circular tube touches the centers of the sides of the diamond. In this example, the seal is not perfect, and a small amount of air may pass in and out of the reservoir through gaps in the
20 corners, as shown in Figure 11.

In one embodiment, the material of the membrane is designed to include marks indicating where the tubes should be inserted. The area of the membrane around the mark may be
25 thinner than the surrounding material to control the position of the tearing so that the entire membrane is not torn when the tubes are pressed into it as shown in Figure 2. In one embodiment the marked area includes a cross-shape surrounded by a circular ring, which is pre-formed during manufacturing
30 of the membrane. The cross-section of the prepared membrane is shown in Figure 4, where the long bar of the cross is indicated 6. The thinner section of the ring 5 limits the tearing so that when the tube is pressed into the cross, the

membrane will tear, but the tear stops when it reaches the circular ring to avoid destroying the membrane entirely.

5 The tube is supported by the static friction between the tube and the membrane. As long as the applied force on the tubing is insufficient to overcome the static friction coefficient between the tube and the membrane, the material of the membrane will deform slightly to compensate and the tube will remain in place. If the force becomes larger than can be
10 absorbed by the deformation of the material and larger than the static coefficient of friction, the tube will slip, alleviating the additional forces on the tube until the coefficient of friction is again reached. The variable extraneous forces are thus substantially eliminated by this
15 stick-slip phenomenon.

If a tighter seal is required around the tubes when they are inserted into the reservoir through the membrane, then the membrane may be made of an elastic material that will attempt
20 to return to its initial shape, forming a tight seal around the tube once it is pressed into the reservoir. The deformation of the elastic membrane in response to the varying forces from the connecting tubes attenuates the influence of the varying forces on the weight measured by the load cell.

25

This is shown in Figures 14-19. The tubes are pressed into the elastic membrane, which then forms a seal around the tube as it attempts to return to its initial shape following piercing by the tube (Figure 19). As the forces on the tube
30 vary, the membrane will deform either up or down, depending on the variation in forces (Figures 17-18). The vertical component of the force exerted on the reservoir will be decomposed into a vertical and horizontal component as the membrane is deformed, so that the vertical force on the

reservoir affecting the load cell measurement will be attenuated by a factor proportional to the length of the lever arm, i.e. the radius of the membrane. The resulting difference in the vertical component of the force applied by the membrane to the plunging tubes when the membrane is displaced by its minimum and maximum amounts is inferior to the force applied to the weight sensor when a quantity of material equivalent to the desired measurement accuracy is added or removed.

10 The previous observations concerning the properties of the membrane apply: the material is fixed to the mouth of the reservoir by gluing or a method of sealing such as heat or ultrasonic sealing that will support the force applied when piercing the membrane as well as the weight of the material inside if the reservoir is turned upside down. If the material being dispensed is corrosive, the material of the membrane is chosen to be resistant to damage by the type of material contained in the reservoir to avoid being weakened or damaged by coming in contact with the contents. However in this case 20 the elastic membrane will tear when the tubes are inserted into the reservoir, but the membrane will deform almost completely without breaking under a variation in pressure from the connecting tubes.

25 **2. Flexible tube sections between the connectors and the dispensing unit** (All the numbers in this paragraph refer to Figures 21-26)

As shown in Figure 21 and Figure 24, a weight sensor 6, for example a load cell, is used to measure the weight of the reservoir 1, the contents of the reservoir 2, the reservoir cap 3, the tube holder 17, the plunged tubes 13, the plunged sensor 14, the flexible tubes 11, the tube contents 12, the sensor wire 8 and other parts related to the dispensing unit

assembly. The weight sensor is connected to the controller 7 using a data link 16. The material being dispensed 2 from the reservoir 1 could be of any type or phase (gas, liquid or solid) including: Inks, solvents or a mixture of both.

5

When all the material has been dispensed, the empty reservoir may be replaced or refilled. The replacement or refilling operation typically requires removing the reservoir cap 3, and replacing the reservoir 1 with another container. During removal, exchange, refill, inspection or other manipulation to the reservoir 1, reservoir cap 3, plunged tubes 13, plunged sensor 14 or any parts that weigh on the sensor 6, the force applied on the reservoir by the tubes 11 and cable 8 may vary. This variation is due partially to movement of the tubes 11 and the cable 8, which are not at exactly the same position before and after the manipulation. In addition, the tubes 11 and/or cable 8 are made of flexible or partially flexible materials that will allow manipulation during maintenance without breaking, while preventing kinks that could block the flow of material being dispensed from the reservoir. Because of these properties, the tubes 11 and cable 8 apply an unwanted variable force to the cap 3 and therefore to the weight sensor 6, which may register a variation in weight despite the fact that the amount of material being dispensed 2 from the reservoir remains the unchanged. The movement of the extremity of the weight sensor 6 is typically less than a few mm at full load.

To overcome described problem, the tubes 11 and cable 8 may be made of very flexible materials that generate a very low force when bent. Due to the small movement of the sensor extremity 6, the amount of unwanted force applied to the cap 3 that is dependent on the tube and/or cable position is reduced.

In this embodiment (Figures 21-23), the first extremity of the flexible tubes 11 and cable 8 are connected to the plunged tubes 13 and sensor 14 using for example standard tubing or cable fixtures. The second extremity of the flexible tubes 11 and cable 8 are connected to the rigid tubes 9 and cable 10, both tied to the tubing holder 5 using tube or cable fixture mechanisms 15 such as, but not restricted to, a hole that crimps the tubes together or off the shelf standard tubing or cable coupling systems. The second extremity of the rigid tubes 9 and cable 10 are usually connected with a dispensing unit, for example a printer or printer head (not shown in the Figures). The fixtures 15 transmit the force applied by the tubes 9 or cable 10 to the tube holder 5, which is connected to the system body 4. The length, orientations and position of the tubes 11 and cable 8 remain approximately the same during removal, exchange, refill, inspection or other manipulation of the reservoir 1, reservoir cap 3, plunged tubes 13 or sensor 14 and the flexibility of the tubes 11 and cable 8 material reduces variation in the resulting force before and after any manipulation.

In another embodiment (Figures 24-26), the first extremity of the flexible tubes 11 and cable 8 are connected to the plunged tubes 13 and sensor 14 using for example standard tube or cable fixtures. The second extremity of the tubes 11 and cable 8 are connected to the flexible tubes 19 and flexible cable 18, both tied to the container holder 22,23 using tube or cable fixture mechanisms 21 such as, but not restricted to, a hole that crimps the tubes together or off the shelf standard tube or cable coupling systems. The other extremity of the flexible tubes 19 and flexible cable 18 are connected to the rigid tubes 9 and cable 10, both tied to the tube holder 5 using tube or cable fixture mechanisms 15 such as,

but not restricted to, a hole that crimps the tubes together or off the shelf standard tube or cable coupling systems.

5 The fixtures 15 transmit the force applied by the tubes 9 or cable 10 to the tube holder 5, which is connected to the system body 4. The length, orientations and position of the tubes 19 and cable 18 remain the same during removal, exchange, refill, inspection or other manipulation of the reservoir 1, reservoir cap 3, plunged tubes 13 or sensor 14
10 and the flexibility of the tubes 19 and cable 18 material reduces variation in the resulting force due to the small movement of the reservoir holder 22,23 relative to the system body 4.

15 The forces applied to cap 3 by the cable 8, tubes 11 and the material contained therein 12 do not interfere with the measurement made by the weight sensor 6 because the concerning force loops do not pass through the weight sensor 6 but are contained within the reservoir holder 22,23. Therefore, the
20 only external forces applied to the parts measured by the weight sensor 6 are the weight of the material being dispensed plus the force applied by the flexible tubes 19 and cable 18. Because these tubes and sensor are never manipulated and only move slightly, the force applied by them is reproducible and
25 does not vary when manipulations to the reservoir 1, reservoir cap 3, plunged tubes 13 or sensor 14 are performed.

3. Sliding Cap (All the numbers in this paragraph refer to Figures 27-29)

30

In another embodiment, a weight sensor 6 is used to measure the weight of the reservoir 1, the material contained in the reservoir 2, the reservoir cap 3, and the cylindrical smooth dry bearing 20.

In a further embodiment, the plunged tubes 13 and the plunged sensor 14 are rigidly held by the tube holder 17. The tube holder 17 is further rigidly attached to the tube holder 5. The first extremity of the tubes 11 and cable 8 is connected to the plunged tubes 13 and sensor 14 using for example standard tube or cable fixtures. The second extremity of the tubes 11 and cable 8 are connected to the rigid tubes 9 and cable 10, both tied to the tube holder 5 using tube or cable fixture mechanisms 15 such as, but not restricted to, a hole that crimps the tubes together or off the shelf standard tube or cable coupling systems. The fixtures 15 transmit the force applied by the tubes 9 or cable 10 to the tube holder 5 connected to the system body 4. The weight sensor 6 is connected to the controller 7 using a data link 16. The material being dispensed 2 from the reservoir 1 could be of any type or phase including: Inks, solvents or a mixture of both.

The tube holder 17 is not attached to the cylindrical smooth dry bearing 20, which is attached firmly to the cap 3. The cylindrical smooth dry bearing 20 is free to slide vertically along the tube holder 17 and in rotation around it.

A weight placed on or removed from the weight sensor 6 results in a vertical deformation that is proportional to the amount of the weight. During the emptying (or the filling) of the reservoir 1, through the plunged tubes 13, the vertical position of the reservoir 1 thus varies. When the vertical position of the reservoir 1 varies, the cylindrical smooth dry bearing 20 (in the reservoir cap 3) slides freely (vertically, and in rotation) along (and around) the tube holder 17.

In this way, during removal, exchange, refill, inspection or other manipulation of the reservoir 1 and the reservoir cap 3, or any parts that weigh on the sensor 6, no force is applied by the plunged tubes 13, plunged sensor 14, the tubes 5 11 and cable 8 because the plunged tubes 13, plunged sensor 14, the tubes 11 and cable 8 are all attached firmly and rigidly to the tube holder 17, itself attached firmly to the tube holder 5, itself connected rigidly to the system body 4.

Claims:

1. Method of making a dispensing apparatus for measuring a quantity of material to be dispensed,
5 the dispensing apparatus having a dispensing unit for dispensing at least part of the material,
the dispensing apparatus having a reservoir containing the material to be dispensed,
the dispensing apparatus further having connectors
10 between the reservoir and the dispensing unit, and the method including the steps of:
placing a scale under the reservoir, the scale being for connection to a processor for processing electronic signals from the scale and for converting the signals
15 into a weight measurement; and
inserting tubes into the reservoir, the tubes carrying material into and from the reservoir, wherein inserting the tubes into the reservoir takes place by means of one of the following:
20 i. through a flexible membrane surrounding the connectors,
ii. with flexible tube sections between the connectors and the dispensing unit, and
iii. through a reservoir cap, the cap sliding relative to
25 the reservoir.
2. A dispensing apparatus for measuring a quantity of material to be dispensed, the dispensing apparatus having:
30 a dispensing unit for dispensing at least part of the material;
a reservoir containing the material to be dispensed;
connectors between the reservoir and the dispensing unit;
a scale under the reservoir, the scale being for connection to a processor for processing electronic

signals from the scale and for converting the signals into a weight measurement; and

tubes inserted into the reservoir, the tubes carrying material into and from the reservoir, the tubes being inserted into the reservoir by means of one of the following:

i. through a flexible membrane surrounding the connectors,

ii. with flexible tube sections between the connectors and the dispensing unit, and

iii. through a reservoir cap, the cap sliding relative to the reservoir.

3. Method as claimed in claim 1, or apparatus as claimed in claim 2, wherein the material is ink or a solvent and the reservoir is contained in a printer.

4. Method or apparatus as claimed in any of the preceding claims, wherein the scale is a load cell.

5. Method or apparatus as claimed in claim 4, wherein the load cell is connected to a processor that filters and processes the electronic signals from the load cell, converting the signals into a weight measurement which is sent to a dispensing application control logic to record the weight during dispensing

6. Method or apparatus as claimed in any of claims 1 to 5, wherein the tubes are inserted into the reservoir through the reservoir cap, a cylindrical smooth dry bearing being attached firmly to the reservoir cap.

7. Method or apparatus as claimed in claim 6, wherein the tubes are inserted into the reservoir through the reservoir cap, the reservoir further including a tube holder rigidly holding plunged tubes and the cylindrical

smooth dry bearing being free to slide vertically along the tube holder.

8. Method or apparatus as claimed in claim 7, wherein the cylindrical smooth dry bearing is free to slide in rotation around the tube holder.
9. Method or apparatus as claimed in any of the preceding claims, the tubes being inserted into the reservoir with the flexible tube sections between the connectors and the dispensing unit, the reservoir including a cap and the dispensing apparatus including at least one of a tubing holder and a reservoir holder.
10. Method or apparatus as claimed in claim 9, wherein the cap includes plunged tubes, one extremity of the tube sections being connected to the plunged tubes.
11. Method or apparatus as claimed in claim 9 and 10, a second extremity of the tube sections being connected to rigid tubes tied to the tubing holder.
12. Method or apparatus as claimed in any of claims 9 to 11, wherein the tubing holder is connected to a body of the dispensing apparatus.
13. Method or apparatus as claimed in any of claims 9 to 11, wherein the dispensing apparatus includes a tubing holder and a reservoir holder, the reservoir holder being connected to the tubing holder by means of the scale.
14. Method or apparatus as claimed in claim 13, wherein the flexible tube sections are tied to the tubing holder, a second extremity of the tube sections being connected to flexible tubes tied to the reservoir holder.

15. Method or apparatus as claimed in any of claims 1 to 5, the tubes being inserted into the reservoir through the flexible membrane, wherein the membrane is fixed to a mouth of the reservoir with a seal across the thickness of the sides of the mouth.
16. Method or apparatus as claimed in any of claims 1 to 5, the tubes being inserted into the reservoir through the flexible membrane, the tubes having one of a shape for piercing the membrane and a cap including a sharp point for piercing the membrane.
17. Method or apparatus as claimed in any of claims 1 to 5, the tubes being inserted into the reservoir through the flexible membrane, wherein the membrane includes marks indicating where the tubes are inserted
18. Method or apparatus as claimed in claim 17, wherein the membrane around the marks is thinner than the surrounding membrane material.
19. A use of the apparatus as claimed in any of claims 2 to 8 for determining the consumption of the material to be dispensed from the dispensing apparatus.
20. The use as claimed in claim 19, wherein the consumption of material is determined while the dispensing unit is in operation.

1/6

Fig. 1
Section A-A

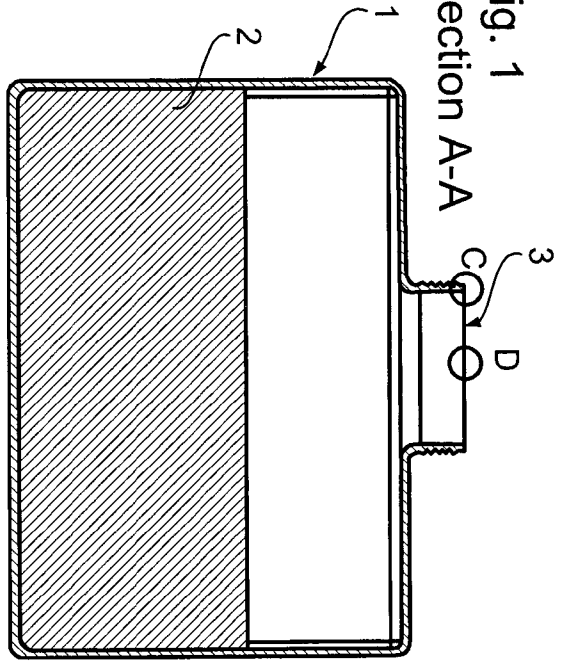

Fig. 2

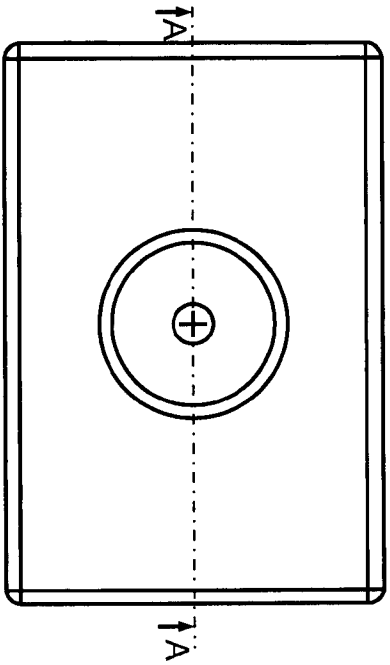

Fig. 4
Detail D

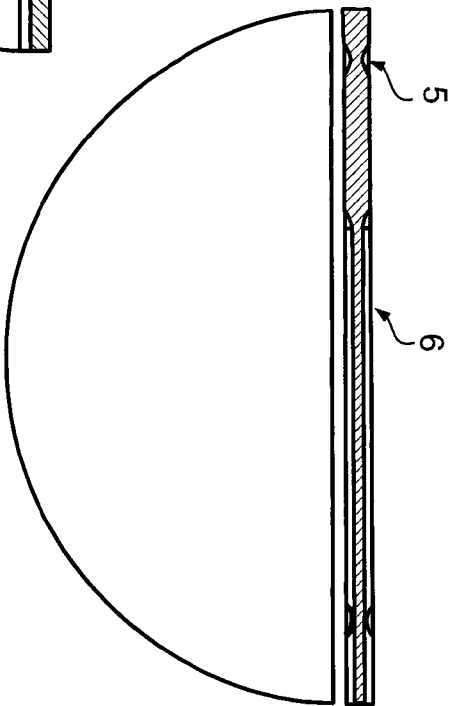

Fig. 3
Detail C

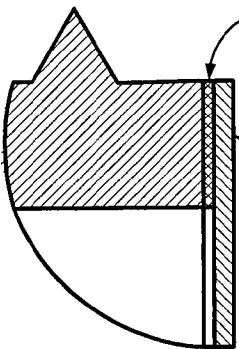

Fig. 5-a

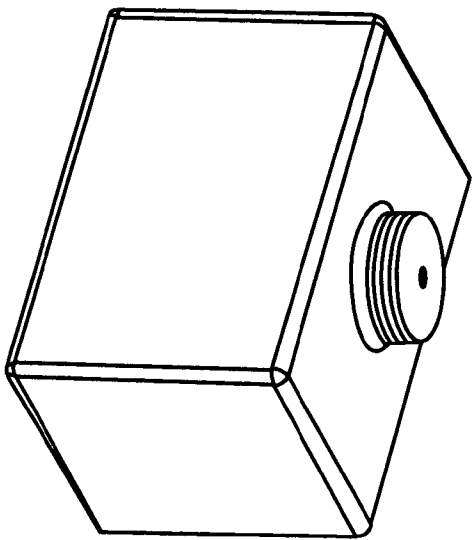
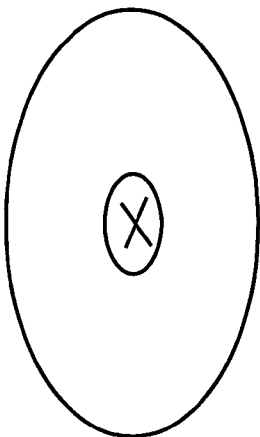

Fig. 5

2/6

Fig. 6
Section B-B

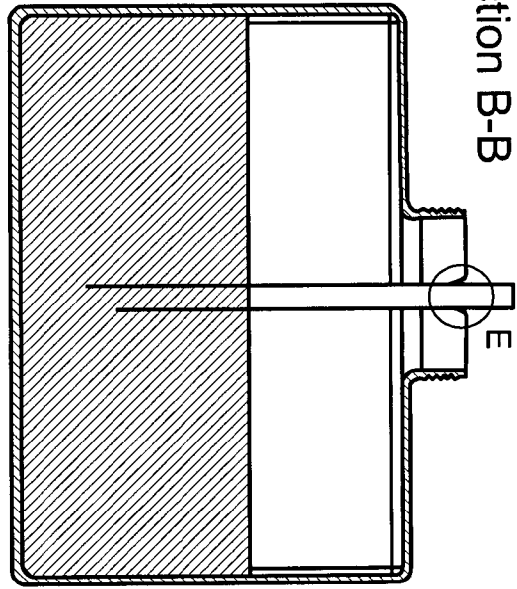

Fig. 8

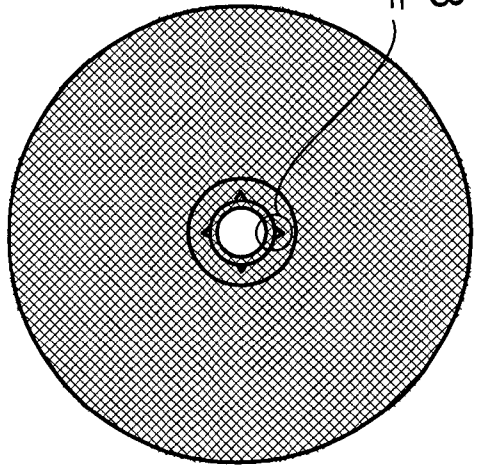

Fig. 11
Detail F

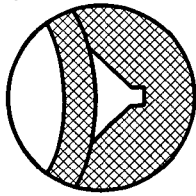

Fig. 7

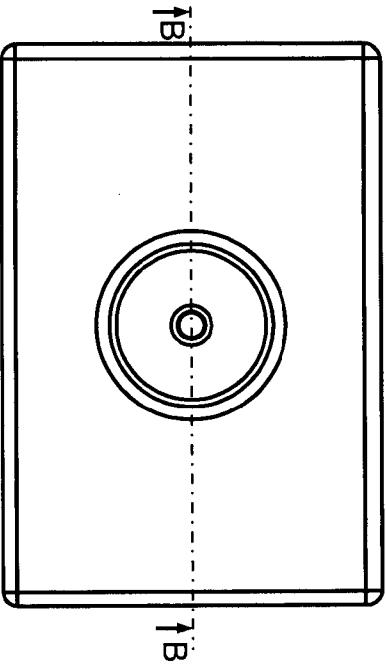

Fig. 12
Detail E

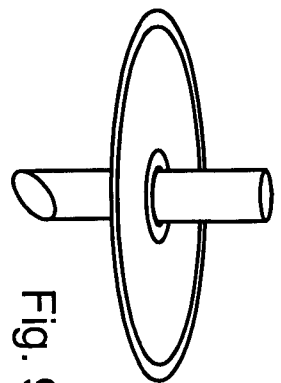
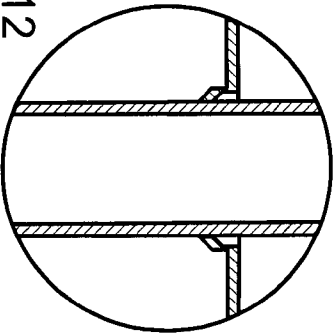

Fig. 9

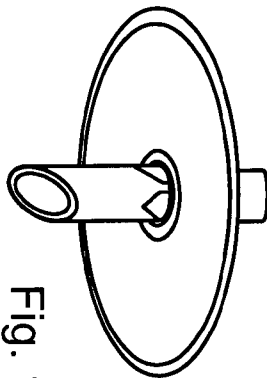

Fig. 10

Fig. 13

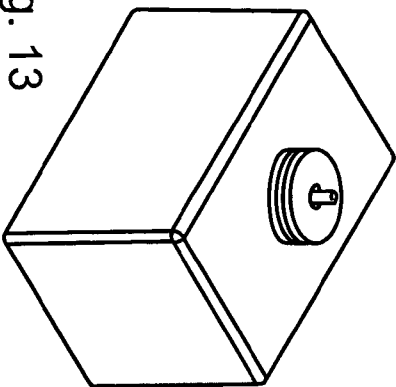

Fig. 14
Section G-G

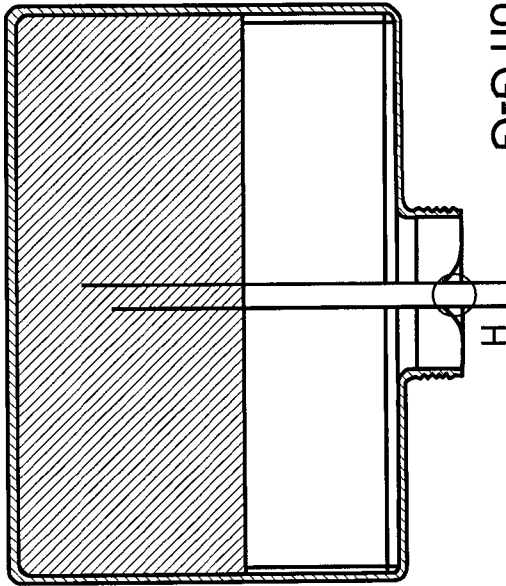

Fig. 15

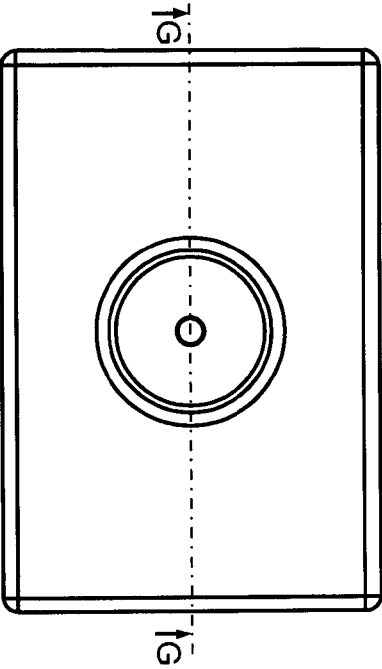

Fig. 16

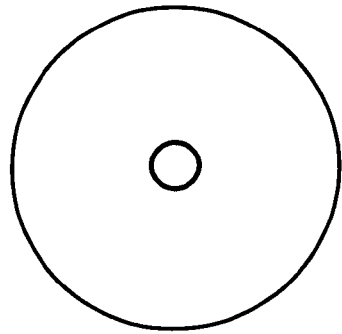

Fig. 19
Detail H

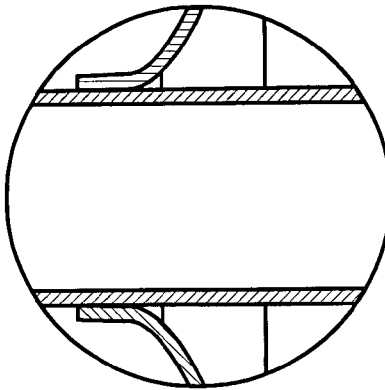

Fig. 17

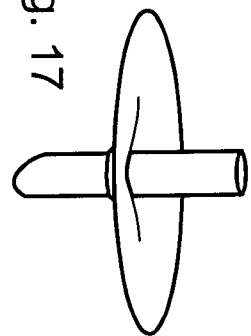

Fig. 18

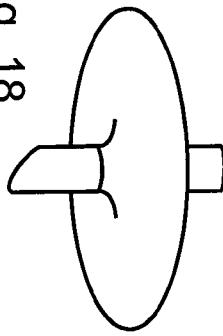
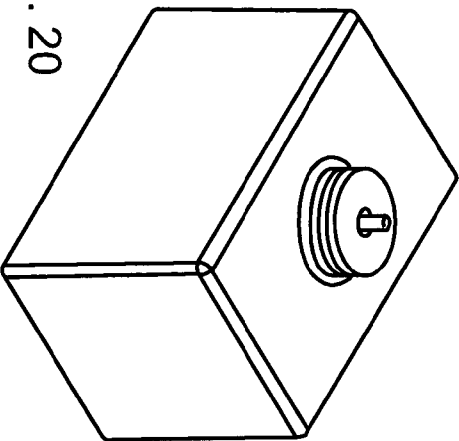

Fig. 20



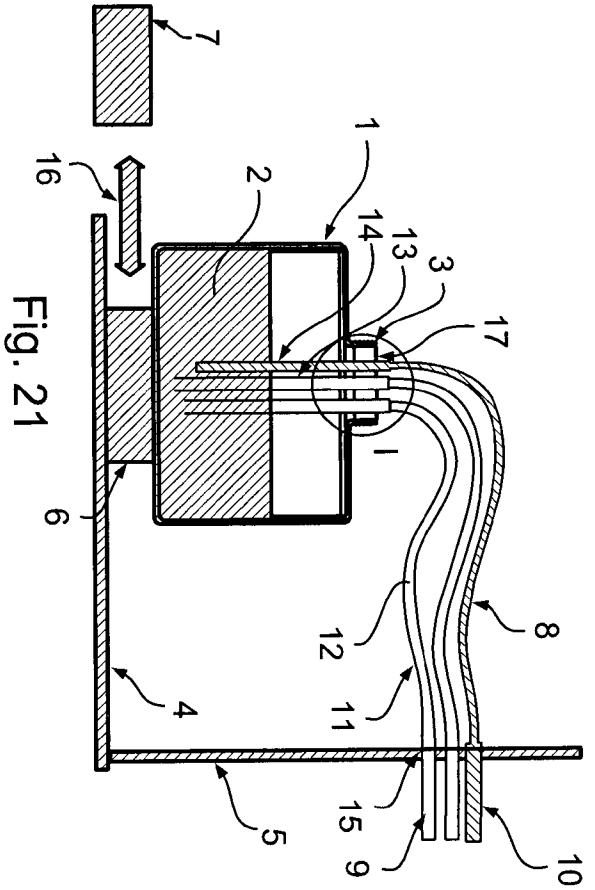

Fig. 21

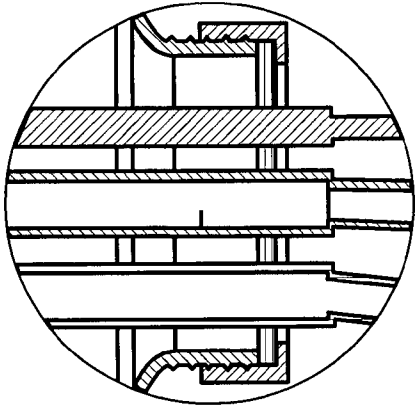

Fig. 22 Detail I

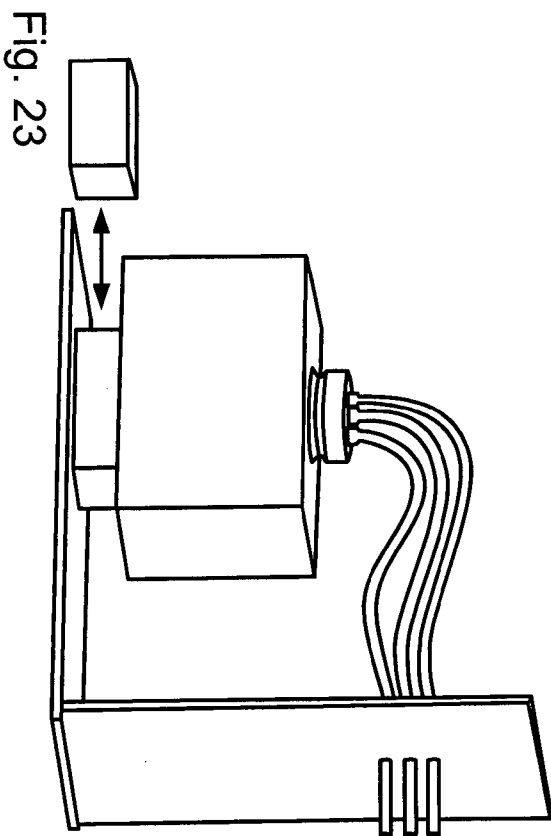

Fig. 23

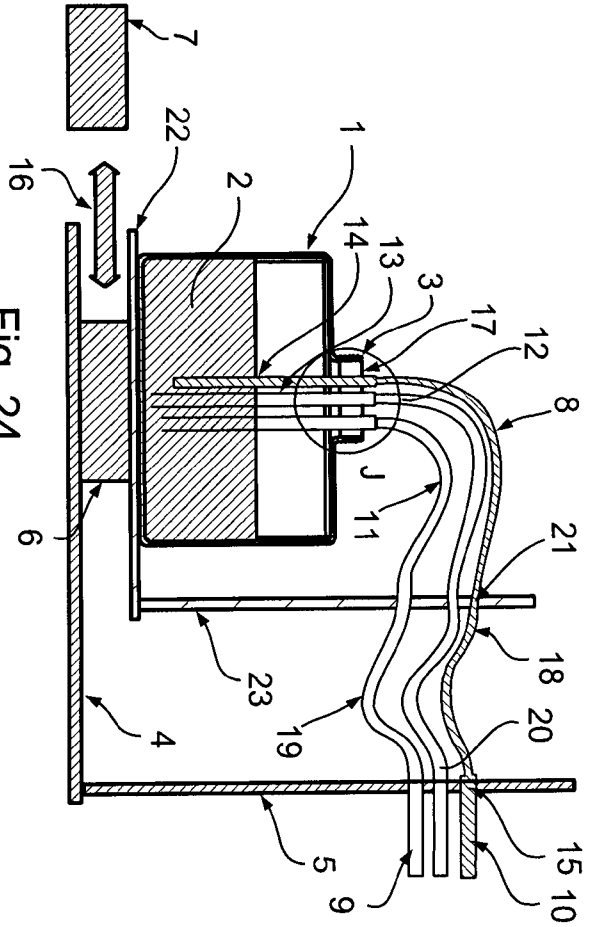

Fig. 24

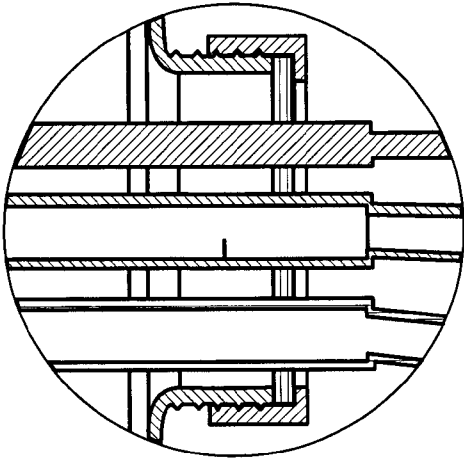

Fig. 25 Detail J

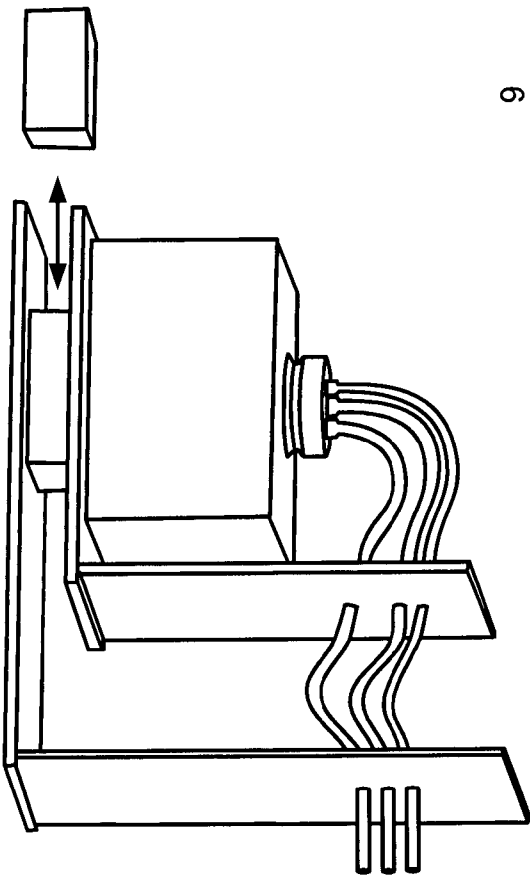

Fig. 26

6/6

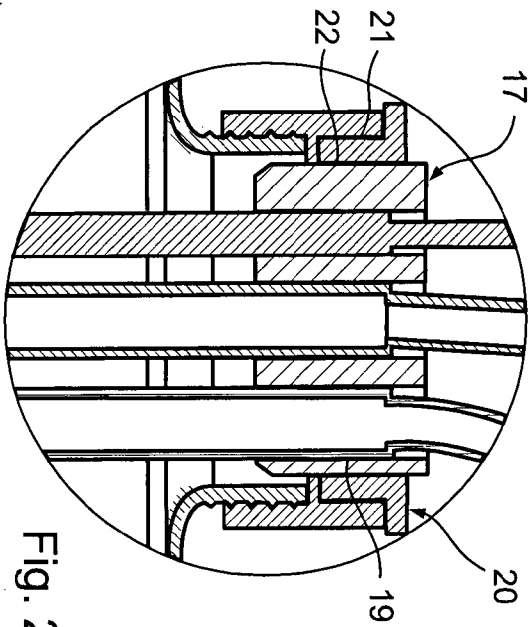

Fig. 28 Detail K

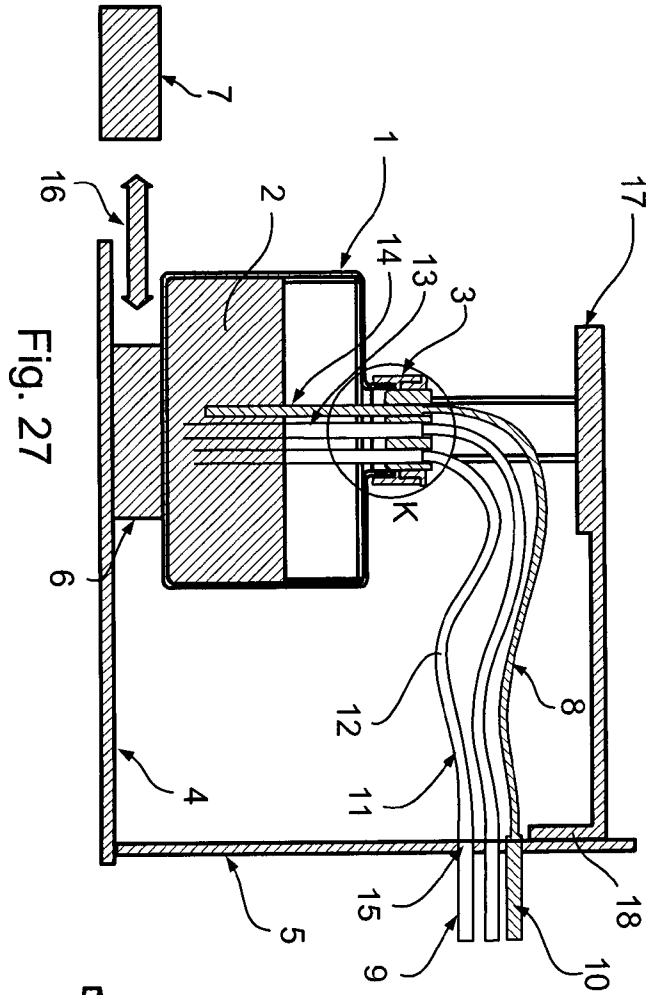

Fig. 27

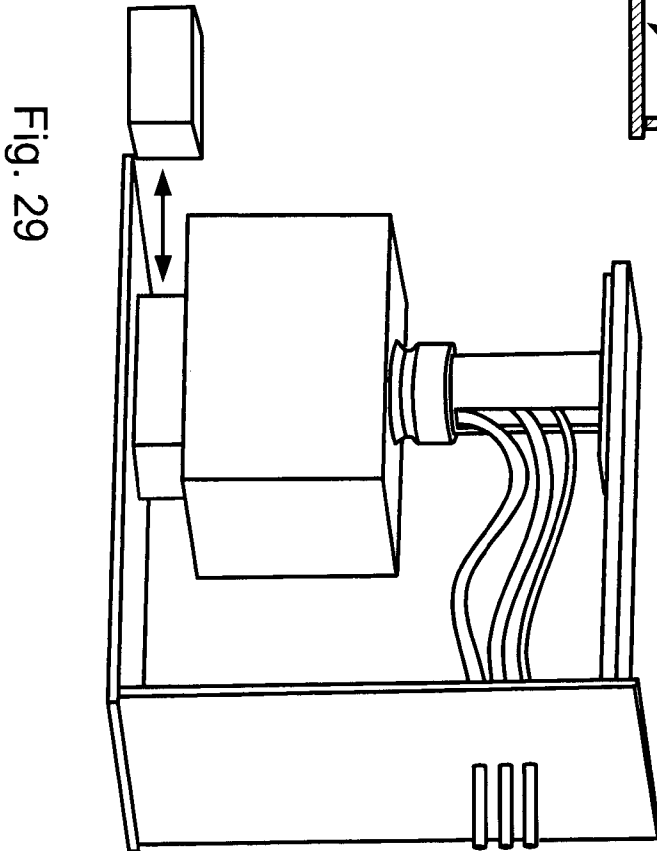

Fig. 29

INTERNATIONAL SEARCH REPORT

International application No
PCT/EP2013/060302

A. CLASSIFICATION OF SUBJECT MATTER
INV. G01G11/08 G01G17/06 B41J2/175
ADD.
According to International Patent Classification (IPC) or to both national classification and IPC

B. FIELDS SEARCHED
Minimum documentation searched (classification system followed by classification symbols)
G01G B41J

Documentation searched other than minimum documentation to the extent that such documents are included in the fields searched

Electronic data base consulted during the international search (name of data base and, where practicable, search terms used)
EPO-Internal, WPI Data

C. DOCUMENTS CONSIDERED TO BE RELEVANT

Category*	Citation of document, with indication, where appropriate, of the relevant passages	Relevant to claim No.
X	US 5 731 824 A (KNEEZEL GARY A [US] ET AL) 24 March 1998 (1998-03-24) column 1, line 32 - column 2, line 5 column 2, line 54 - column 3, line 36 column 3, line 60 - column 4, line 24 column 4, line 35 - column 5, line 3 column 5, line 64 - column 7, line 13 figures 1, 4-7	1-20
X	WO 2004/044816 A1 (OBJET GEOMETRIES LTD [IL]; MENCHIK GUY [IL]; GOTHAIT HANAN [IL]; KRITC) 27 May 2004 (2004-05-27) page 8, line 3 - page 11, line 5 figures 1-5 ----- -/--	1-20

Further documents are listed in the continuation of Box C.

See patent family annex.

* Special categories of cited documents :

- "A" document defining the general state of the art which is not considered to be of particular relevance
- "E" earlier application or patent but published on or after the international filing date
- "L" document which may throw doubts on priority claim(s) or which is cited to establish the publication date of another citation or other special reason (as specified)
- "O" document referring to an oral disclosure, use, exhibition or other means
- "P" document published prior to the international filing date but later than the priority date claimed

"T" later document published after the international filing date or priority date and not in conflict with the application but cited to understand the principle or theory underlying the invention

"X" document of particular relevance; the claimed invention cannot be considered novel or cannot be considered to involve an inventive step when the document is taken alone

"Y" document of particular relevance; the claimed invention cannot be considered to involve an inventive step when the document is combined with one or more other such documents, such combination being obvious to a person skilled in the art

"&" document member of the same patent family

Date of the actual completion of the international search 12 August 2013	Date of mailing of the international search report 28/08/2013
---	--

Name and mailing address of the ISA/ European Patent Office, P.B. 5818 Patentlaan 2 NL - 2280 HV Rijswijk Tel. (+31-70) 340-2040, Fax: (+31-70) 340-3016	Authorized officer Koch, Florian
--	---

INTERNATIONAL SEARCH REPORT

International application No

PCT/EP2013/060302

C(Continuation). DOCUMENTS CONSIDERED TO BE RELEVANT		
Category*	Citation of document, with indication, where appropriate, of the relevant passages	Relevant to claim No.
X	DE 40 02 255 A1 (FLUID VERFAHRENSTECHNIK GMBH [DE]) 1 August 1991 (1991-08-01)	1,2, 4-14,19, 20
A	column 2, line 15 - line 50 column 4, line 48 - column 6, line 21 figure 1 -----	3,15-18

INTERNATIONAL SEARCH REPORT

Information on patent family members

International application No

PCT/EP2013/060302

Patent document cited in search report	Publication date	Patent family member(s)	Publication date
US 5731824	A	24-03-1998	JP H09183237 A
			US 5731824 A

WO 2004044816	A1	27-05-2004	AT 393009 T
			AU 2003279508 A1
			DE 60320588 T2
			EP 1581902 A1
			EP 1938952 A2
			EP 2298539 A1
			US 2006127153 A1
			US 2010208016 A1
			US 2011289791 A1
			WO 2004044816 A1

DE 4002255	A1	01-08-1991	AT 115720 T
			DE 4002255 A1
			DK 0516897 T3
			EP 0516897 A1
			ES 2065612 T3
			GR 3015220 T3
