

(19) World Intellectual Property Organization
International Bureau



(43) International Publication Date
13 December 2007 (13.12.2007)

PCT

(10) International Publication Number
WO 2007/142458 A1

- (51) International Patent Classification:
G02B 5/30 (2006.01)
- (21) International Application Number:
PCT/KR2007/002733
- (22) International Filing Date: 5 June 2007 (05.06.2007)
- (25) Filing Language: English
- (26) Publication Language: English
- (30) Priority Data:
10-2006-0051636 8 June 2006 (08.06.2006) KR
- (71) Applicant (for all designated States except US): **LG CHEMICAL LTD.** [KR/KR]; 20 Youido-dong, Youngdeungpo-gu, Seoul 150-010 (KR).

- Booheung-dong Mok-po, Cheonanam-do 530-768 (KR). **PARK, Moon-Soo** [KR/KR]; 5-405 Cheongsol Apt. Samcheon-dong Seo-gu, Daejeon 302-743 (KR).
- (74) Agent: **C & S LOGOS PATENT AND LAW OFFICE**; 13th Floor, Seocho-Pyunghwa Building, 1451-34 Seocho-dong, Seocho-gu, Seoul 137-070 (KR).
- (81) Designated States (unless otherwise indicated, for every kind of national protection available): AE, AG, AL, AM, AT, AU, AZ, BA, BB, BG, BH, BR, BW, BY, BZ, CA, CH, CN, CO, CR, CU, CZ, DE, DK, DM, DO, DZ, EC, EE, EG, ES, FI, GB, GD, GE, GH, GM, GT, HN, HR, HU, ID, IL, IN, IS, JP, KE, KG, KM, KN, KP, KZ, LA, LC, LK, LR, LS, LT, LU, LY, MA, MD, ME, MG, MK, MN, MW, MX, MY, MZ, NA, NG, NI, NO, NZ, OM, PG, PH, PL, PT, RO, RS, RU, SC, SD, SE, SG, SK, SL, SM, SV, SY, TJ, TM, TN, TR, TT, TZ, UA, UG, US, UZ, VC, VN, ZA, ZM, ZW.
- (84) Designated States (unless otherwise indicated, for every kind of regional protection available): ARIPO (BW, GH, GM, KE, LS, MW, MZ, NA, SD, SL, SZ, TZ, UG, ZM, ZW), Eurasian (AM, AZ, BY, KG, KZ, MD, RU, TJ, TM), European (AT, BE, BG, CH, CY, CZ, DE, DK, EE, ES, FI, FR, GB, GR, HU, IE, IS, IT, LT, LU, LV, MC, MT, NL, PL, PT, RO, SE, SI, SK, TR), OAPI (BF, BJ, CF, CG, CI, CM, GA, GN, GQ, GW, ML, MR, NE, SN, TD, TG).

- (72) Inventors; and
- (75) Inventors/Applicants (for US only): **JEON, Byoung-Kun** [KR/KR]; #203 LG Dormitory House Doryong-dong Yuseong-gu, Daejeon 305-340 (KR). **BELYAEV, Sergey** [RU/KR]; #201 LG Dormitory House Doryong-dong Yuseong-gu, Daejeon 305-340 (KR). **YUN, Chang-Hun** [KR/KR]; 601-1503 Oceanvill Apt.

[Continued on next page]

(54) Title: INTEGRATED O FILM FOR IMPROVING VIEWING ANGLE OF TN-LCD, AND POLARIZER PLATE AND TN-LCD INCLUDING THE SAME

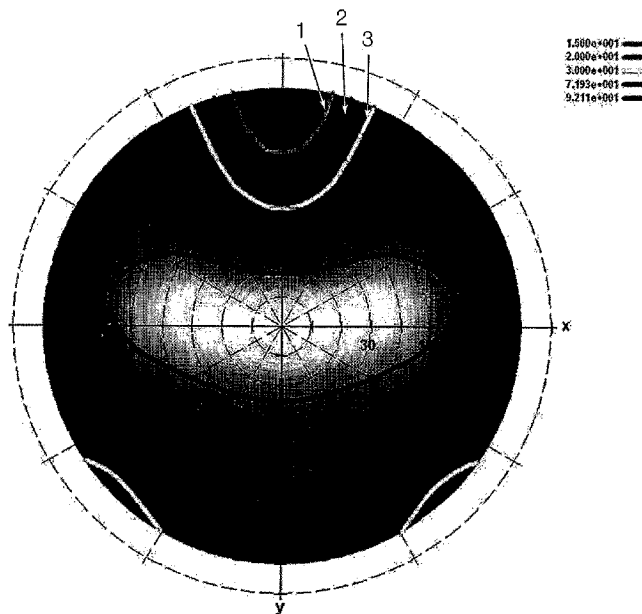

(57) Abstract: Disclosed herein are an integrated O film for improving a viewing angle of a TN-LCD, and a polarizer plate and TN-LCD including the same. Also disclosed herein are a compensation film which is capable of improving a contrast characteristic at a front side and an inclination angle and minimizing a color variation according to a viewing angle in a dark state, and a polarizer plate and TN-LCD including the same. The integrated O film includes a transversely-stretched negative biaxial (B) film and a positive O film laminated on the transversely-stretched negative B film.

WO 2007/142458 A1



Published:

— with international search report

For two-letter codes and other abbreviations, refer to the "Guidance Notes on Codes and Abbreviations" appearing at the beginning of each regular issue of the PCT Gazette.

Description

INTEGRATED O FILM FOR IMPROVING VIEWING ANGLE OF TN-LCD, AND POLARIZER PLATE AND TN-LCD INCLUDING THE SAME

Technical Field

- [1] The present invention relates to an integrated O film for improving a viewing angle of a twisted nematic liquid crystal display (TN-LCD), and a polarizer plate and a TN-LCD including the same, and more particularly, a compensation film, which is capable of improving a contrast characteristic at a front side and an inclination angle and minimizing a color variation according to a viewing angle in a dark state, and a polarizer plate and a TN-LCD including the same.

[2]

Background Art

- [3] A liquid crystal display (LCD) is a display device for implementing a desired image by selectively transmitting light emitted from a backlight using a polarization phenomenon of liquid crystal.
- [4] FIG. 1 shows a phenomenon for selectively transmitting light in a TN-LCD used widely. As shown in FIG. 1A, an angle between the polarization axes between a light source side polarizer plate 10 and a viewer side polarizer plate 20 is 90° . Nematic liquid crystal molecules 30 are filled between the two polarizer plates and the liquid crystal molecules 30, which are close to the polarizer plates, are aligned in the same directions as the polarization axes of the polarizer plates. Accordingly, the alignment directions of the liquid crystal molecules which are close to the two polarizer plates are orthogonal to each other, similar to the polarizer plates. In addition, the liquid crystal molecules in a middle portion are twisted as shown in the drawing.
- [5] Accordingly, light 40 polarized by the light source side polarizer plate rotates by 90° by the nematic liquid crystal molecules and, as a result, passes through the viewer side polarizer plate.
- [6]
- [7] However, when an electrical field is applied to the liquid crystal molecules 30, the liquid crystal molecules 30 are arranged parallel to the direction of the electrical field as shown in FIG. 1b. Accordingly, the light 40 which passes through the light source side polarizer plate 10 does not rotate and reaches the viewer side polarizer plate 20 in the direction polarized by the light source side polarizer plate such that the light does not transmit through the viewer side polarizer plate 20 which rotates by 90° with respect to the light source side polarizer plate 10.

- [8] The LCD controls the transmission and blocking of the light by selectively applying the electrical field to each pixel using the above-described phenomenon.
- [9] In the LCD, the contrast characteristic is improved when the light is surely transmitted and blocked such that a bright state and a dark state appear. In particular, when light leakage is minimized in the dark state, it is possible to improve the contrast characteristic. No problem is caused in the contrast characteristic when a display device is viewed from the front side, but the light leakage is unlikely to be perfectly prevented in the dark state when the display device is viewed at an inclination angle. As described above, in the LCD, the light is blocked by providing a polarizer plate having a transmission axis perpendicular to the light polarized linearly at the viewer side using a polarization phenomenon. However, when the light which reaches the viewer side polarizer plate is not perfectly linearly polarized, a portion of the light may be leaked.
- [10] Such a phenomenon may occur when the light travels in an inclination direction (in the viewer's direction), not in a vertical direction. That is, the dark state is perfectly implemented when the nematic liquid crystal molecules are aligned parallel to the traveling direction of the light as shown in FIG. 1b. Accordingly, since the alignment direction of the liquid crystal molecules and the traveling direction of the light are not perfectly parallel to each other when the light travels in the inclination direction, an additional phase variation occurs and thus the light is not perfectly blocked.
- [11]
- [12] Another reason why the light leakage occurs in the dark state is because the liquid crystal molecules are aligned in a horizontal direction equal to the orientation of an alignment film, not parallel to the direction of the electrical field, in the boundary between the alignment film and the liquid crystal (that is, the polarizer plate side), and become aligned parallel to the direction of the electrical field as getting away from the boundary between the alignment film and the liquid crystal, as shown in FIG. 2. Accordingly, there is caused a so-called splay alignment that the inclination angles of the liquid crystal molecules gradually increase to be close to 90 from the boundary between the alignment film and the liquid crystal to the center of the liquid crystal layer.
- [13] The light may not be perfectly blocked in the dark state by the splay alignment of the liquid crystal layer.
- [14] Conventionally, a variety of technologies were suggested in order to prevent the light leakage. For example, Korean Patent Publication No. 10-0376378 discloses the technology of improving the gray-scale characteristic and reducing light leakage using an O film. In this technology, variations in light leakage amount among gray scales according to viewing angles are minimized by an O-plate compensator having an in-

clination angle. In this technology, since light leakage amount can be properly controlled according to the viewing angles, it is possible to manufacture a LCD having a high gray-scale characteristic regardless of the viewing angle.

[15] However, in this technology, since the O film is directly formed on a glass substrate, productivity deteriorates. That is, in order to manufacture the O-plate compensator, a low pretilt alignment layer and high pretilt alignment layer are formed on the glass substrate. In this case, it takes much time to perform the process of forming the layers on the glass substrate and it is difficult to manage the substrate.

[16] In addition, in the conventional method, light leakage which occurs by the splay alignment of the liquid crystal molecules can be reduced. However, the light leakage due to the +C alignment of liquid crystal molecules (that is, since the liquid crystal molecules are aligned parallel to the direction of the electrical field, the light can be prevented from leaking to the front side. However, when the light travels in an inclination direction, a retardation occurs and thus a perfect dark state cannot appear) is unlikely to be reduced.

[17] When light reaches the polarizer plate at an inclination angle, a slight phase retardation occurs in the polarizer plate, thereby causing light leakage. However, in the Korean Patent Publication No. 10-0376378, it is difficult to perfectly prevent light from leaking due to such various causes.

[18]

Disclosure of Invention

Technical Problem

[19] The present invention has been made to solve the foregoing problems of the prior art and therefore an aspect of the present invention is to provide an integrated O film for improving a viewing angle of a TN-LCD having a improved contrast characteristic, gray-scale characteristic or color characteristic by blocking various kinds of factors for causing light leakage, and a polarizer plate and a TN-LCD including the same.

[20]

Technical Solution

[21] According to an aspect of the present invention, there is provided an integrated O film comprising a transversely-stretched negative biaxial (B) film, and a positive O film laminated on the transversely-stretched negative B film.

[22] According to another aspect of the present invention, there is provided a polarizer plate comprising: a polarization film; and an integrated O film laminated on the polarization film, wherein the integrated O film includes a transversely-stretched negative biaxial (B) film and a positive O film laminated on the transversely-stretched negative B film, and wherein in-plane optical axes of the polarization film and the transversely-

stretched negative B film are orthogonal to each other.

[23] According to another aspect of the present invention, there is provided a twisted nematic liquid crystal display (TN-LCD) comprising: a pair of glass plates which face each other; twisted nematic liquid crystal filled between the glass plates; polarizer plates attached to the outsides of the glass plates, wherein each of the polarizer plates include a polarization film and an integrated O film laminated on the polarization film, wherein the integrated O film includes a transversely-stretched negative biaxial (B) film and a positive O film laminated on the transversely-stretched negative B film.

[24] The value N_z of the negative B film expressed by Equation 1 may be 0.1 to 2.

[25] Equation 1

[26]

$$N_z = \left| \left(\frac{n_z - n_y}{n_x - n_y} \right) \right|$$

[27] where, n_x , n_y , and n_z denote refractive indexes of x, y and z directions, respectively.

[28] The thickness retardation value of the negative film may be -50 to -150 nm.

[29] More preferably, the value N_z of the negative B film may be 0.3 to 1.

[30] An average tilt angle of the positive O film expressed by Equation 2 may be 30° to 50° and a maximum value of the tilt angle may be 50° to 90°.

[31] Equation 2

[32]

$$\theta_{average} = \frac{\int_0^d \theta(z) dz}{d}$$

[33] where, d denotes a thickness of the film and $\theta(z)$ denotes a tilt angle of the film in a vertical position z.

[34] An in-plane retardation value of the positive O film may be 50 to 150 nm.

[35] The positive O film may include nematic liquid crystal.

[36] An alignment film interposed between the negative B film and the positive O film may be further included.

[37] The alignment film may be an acrylic-based alignment film.

[38] The alignment film may be an optical alignment film having an alignment characteristic by irradiation of polarized ultraviolet rays.

[39] The alignment film may include polynorbornene cinnamate or polyimide cinnamate.

[40]

Advantageous Effects

[41] As described above, an integrated O film according to the present invention is man-

ufactured by laminating a positive O film and a negative B film under an optimal condition. Accordingly, it is possible to prevent light leakage in all directions and to manufacture a TN-LCD capable of improving a contrast characteristic, gray scale characteristic and color characteristic by using the integrated O film according to the present invention.

Brief Description of the Drawings

- [42] The above and other aspects, features and other advantages of the present invention will be more clearly understood from the following detailed description taken in conjunction with the accompanying drawings, in which:
- [43] FIGS. 1A and 1B respectively are views showing a bright state and a dark state of a TN-LCD;
- [44] FIG. 2 is a schematic view showing the splay alignment of liquid crystal molecules when an electrical field is applied to a TN-LCD;
- [45] FIG. 3 is a schematic view showing the splay alignment state of a positive O film;
- [46] FIG. 4 is a graph showing a contrast characteristic distribution of a TN-LCD according to Embodiment 1 of the present invention;
- [47] FIG. 5 is a graph showing a color characteristic distribution of the TN-LCD according to Embodiment 1 of the present invention;
- [48] FIG. 6 is a graph showing a contrast characteristic distribution of a TN-LCD according to Embodiment 2 of the present invention;
- [49] FIG. 7 is a graph showing a color characteristic distribution of the TN-LCD according to Embodiment 2 of the present invention;
- [50] FIG. 8 is a graph showing a contrast characteristic distribution of a TN-LCD including a negative O film, for the purpose of comparison with the present invention; and
- [51] FIG. 9 is a graph showing a color characteristic distribution of a TN-LCD including a negative O film, for the purpose of comparison with the present invention.

[52]

Best Mode for Carrying Out the Invention

- [53] Hereinafter, the present invention will be described in detail.
- [54] As described above, light leakage occurs because light polarized by a light source side polarizer plate is subjected to a retardation before reaching a viewer side polarizer plate and thus the light cannot reach the viewer side polarizer plate in a perfectly linearly polarized state vertical to a transmission axis of the viewer side polarizer plate.
- [55] The retardation for causing light leakage is classified into three types as follows:
- [56] 1) A retardation which occurs when a TN-LCD is vertically erected, a viewing angle is not parallel to the alignment direction of the liquid crystal molecules, and thus light

travels at the viewing angle,

[57] 2) A retardation which occurs by a splay alignment portion of a TN-LCD (liquid crystal molecules in a portion close to an alignment film or in a gray state may be aligned in a splay alignment manner), and

[58] 3) A retardation which occurs when light obliquely enters a polarizer plate.

[59] Accordingly, in order to prevent light from leaking, all the above-described retardations must be compensated.

[60] The inventors of the present invention carry out research on such problems and confirm that all the retardations which occur in various patterns can be compensated when a positive O film and a negative biaxial (B) film are arranged under an adequate condition. Hereinafter, an integrated O film refers to a lamination of a positive O film and a negative B film, and an O film refers to an O film layer.

[61] Among the films, the O film is to compensate a retardation which occurs (that is, a retardation which occurs due to a splay alignment) when, since an electrical field is applied to liquid crystal molecules, the liquid crystal molecules are not vertically aligned in the boundary between an alignment film and the liquid crystal, that is, are aligned parallel to the alignment direction of the alignment film, and the liquid crystal molecules become gradually more tilted in the direction of the electrical field.

[62] As shown in FIG. 3, the molecules of the O film are preferably splay-aligned. In the splay alignment of the molecules of the O film, an average tilt angle θ_{average} defined by Equation 3 is in a range of 30° to 50° and a maximum tilt angle is preferably in a range of 50° to 90° and more preferably in a range of 60° to 90°.

[63] Equation 3

[64]

$$\theta_{\text{average}} = \frac{\int_0^d \theta(z) dz}{d}$$

[65] where, d denotes the thickness of the film and $\theta(z)$ denotes a tilt angle at a vertical position z in the film.

[66] At this time, the O film is preferably formed of nematic liquid crystal. That is, the O film is formed of liquid crystal, for the splay or oblique alignment. When the O film is formed of discotic liquid crystal, an optical axis separation angle occurs. The optical axis separation angle indicates an angle between the alignment direction of the liquid crystal molecules and a rubbing direction for aligning the liquid crystal molecules. When the optical axis separation angle occurs, front contrast ratio and color characteristic deteriorate. That is, when the optical axis separation angle occurs, light

leakage occurs at the front side and more particularly blue light leakage significantly increases. Accordingly, a front color becomes blue and the contrast deteriorates. In order to prevent contrast and color failures due to the optical axis separation angle, the optical axis separation angle should be managed within $\pm 0.5^\circ$. However, since the discotic liquid crystal molecule has a coin shape and is symmetrical with respect to all directions, the discotic liquid crystal molecules are unlikely to be aligned in a uniform direction and thus are not suitable for managing the optical axis separation angle. In contrast, since the nematic liquid crystal molecule has a rod shape, the nematic liquid crystal molecules are easily aligned in a rubbing direction and are suitable for managing the optical axis separation angle. Thus, the nematic liquid crystal is preferably used.

[67] The negative B film is an anisotropic film having the following relationship when the refractive indexes of x, y, and z directions are respectively n_x , n_y , and n_z .

[68] Equation 4

$$[69] \quad n_x \neq n_y > n_z$$

[70] The negative B film respectively has optical axes in a direction c (vertical to the surface of the film) and a direction c (parallel to the surface of the film) and performs a function similar to that of a negative C plate by the optical axis component of the direction c. Accordingly, a retardation which occurs by a positive C plate formed of liquid crystal by emitting light at an inclination angle is cancelled by a negative C plate.

[71] The direction a, which is the other optical axis of the negative B film, serves to cancel a retardation which may occur when light enters the polarizer plate at an inclination angle.

[72] The negative B film may be preferably a transversely-stretched film. As the transversely-stretched film, a biaxially stretched cyclo-olefin polymer (COP) film, a biaxially stretched polycarbonate (PC) film, a uniaxially stretched triacetate cellulose (TAC) and poly norbornene film may be used. A biaxial liquid crystal may also be used.

[73] Accordingly, the positive O film and the negative B film serve to cancel the three retardations. However, the positive O film and the negative B film must be used by the following proper combination such that the effect of the present invention can be obtained.

[74] A lamination of the O film and the B film is used. In the lamination, the optical axis of the O film and the optical axis (optical axis parallel to the surface of the film out of the two optical axes) of the B film need to be orthogonal to each other.

[75] In the lamination, the O film and the B film have adequate retardation values in order to cancel the retardation effect due to the inclination angle.

[76] That is, each film has an in-plane retardation value according to Equation 5 and a thickness retardation value according to Equation 6, all of which are in respective adequate ranges. In Equations, d denotes the thickness of the film and n_x , n_y and n_z denote the refractive indexes of x, y, and z directions.

[77] Equation 5

[78] In-plane retardation value (R_{in}) = $d \times (n_x - n_y)$

[79] Equation 6

[80] Thickness retardation value (R_{th}) = $d \times (n_z - n_y)$

[81] The present inventors obtained the researched result that the in-plane retardation value R_{in} of the B film for preventing light leakage when light reaches the polarizer plate at the inclination angle should be 150 to 250 nm. If the in-plane retardation value is less than 150 nm, the light leakage significantly increases and thus a contrast ratio decreases. In contrast, if in-plane retardation value is greater than 250 nm, the color of the dark state unpreferably varies.

[82] If the in-plane retardation value of the B film is in the above-described range, a value N_z expressed by Equation 7 is preferably in a range of 0.1 to 2 in order to further improve the contrast ratio. If the value N_z is less than 0.1, the contrast ratio decreases. In contrast, if the value N_z is greater than 2, a variation in color of the dark state unpreferably increases. It is more preferable that the value N_z is in a range of 0.3 to 1.

[83] Equation 7

[84]

$$N_z = \left| \left(\frac{n_z - n_y}{n_x - n_y} \right) \right|$$

[85] Equation 7 indicates a ratio of the thickness retardation value R_{th} to the in-plane retardation value R_{in} . Accordingly, since the preferable range of the in-plane retardation value R_{in} is previously obtained, the range of the thickness retardation value can be obtained by Equation 5.

[86] The thickness retardation value of the B film for further improving a contrast ratio while satisfying Equation 7 is -50 to -150 nm.

[87] The integrated O film is formed by laminating the O film on the B film. The retardation value of the O film should be determined in consideration of the retardation value of the B film. According to the researched result of the present inventors, it is preferable that the proper in-plane retardation value of the O film is 50 to 150 nm and the thickness retardation value is 50 to 150 nm.

[88] The various retardations can be cancelled by the combination of the positive O film and the negative B film. Accordingly, a good contrast characteristic, color characteristic and gray scale characteristic can be obtained in a wide viewing angle.

- [89] In the integrated O film, an alignment film may be further formed on the B film base in order to align the O film on the B film in a necessary direction. At this time, the alignment film is preferably an acrylic-based alignment film, for example, an alignment film including a mixture of penta acrylate and modified poly vinyl alcohol (PVA). Instead of the acrylic-based alignment film, an optical alignment film having an alignment characteristic by irradiation of polarized ultraviolet rays may be used as the alignment film. The example of the optical alignment film may include poly-norbornene cinnamate or polyimide cinnamate.
- [90] The present invention provides a polarizer plate and a TN-LCD including the integrated O film including the O film and the B film.
- [91] In the polarizer plate, the polarization film, the B film and the O film are laminated in this order, or the polarization film, the O film and the B film are laminated in this order (That is, the integrated O film is laminated on the polarization film). The B film is laminated such that the in-plane optical axis of the B film is orthogonal to the absorption axis of the polarizer plate. The O film is laminated such that the optical axis of the O film is orthogonal to the in-plane optical axis of the B film.
- [92] Integrated O films laminated on polarizer plates may have the characteristic of the integrated O film according to the present invention.
- [93] The present invention also provides a TN-LCD including a pair of glass plates which face each other, twisted nematic liquid crystal filled between the glass plates, and polarizer plates attached to the outsides of the glass plates. That is, the TN-LCD according to the present invention includes the polarizer plate, the glass plate, the liquid crystal, the glass plate and the polarizer plate, all of which are arranged in this order. The TN-LCD according to the present invention includes the polarizer plate having the characteristic of the above-described lamination.
- [94] Accordingly, the integrated O film which is the lamination included in the polarizer plate includes all the characteristics of the integrated O film according to the present invention.
- [95] When the above-described TN-LCD is used, it is possible to minimize light leakage due to the retardation compensation effect of the integrated O film.

[96]

Mode for the Invention

[97] Embodiment 1

[98] A LCD having a dielectric anisotropy of $\Delta\epsilon > 0$ and refractive indexes of liquid crystal of $n_e = 1.595$ and $n_o = 1.5$ and including an LCD panel having a thickness of $4.8\mu\text{m}$ and a compensation film was manufactured. A polarization film is aligned at an angle of 45° with horizontal direction of LCD Panel and the absorption axis of the po-

larization film is parallel to the optical axis of the LCD panel. An integrated O film was interposed between the LCD panel and the polarization film.

- [99] The integrated O film was manufactured by coating a negative B film with a splay-aligned liquid crystal film (O film). The optical axis of the O film was orthogonal to that of the B film. The absorption axis of the polarization film was parallel to the optical axis of the O film and the absorption axis of the polarization film was orthogonal to the optical axis of the negative B film.
- [100] A counter polarization film was provided on the outside of the LCD panel. The absorption axis of the counter polarization film was aligned at an angle of 135° with horizontal direction of LCD Panel and an integrated O film was interposed between the LCD panel and the counter polarization film. The absorption axis of the counter polarization film was parallel to the optical axis of the O film and was orthogonal to the optical axis of the negative B film, similar to the above-described polarization film.
- [101] The O film included in the integrated film has an in-plane retardation value of $R_{in} = 60$ nm and is formed of nematic liquid crystal. In the splay alignment of the O film, an average tilt angle expressed by Equation 3 was 45° . The in-plane retardation value of the negative B film is $R_{in} = 190$ nm and the thickness retardation value thereof is $R_{th} = -100$ nm.
- [102] The contrast characteristic is shown in FIG. 4 and the color characteristic is shown in FIG. 5. In the drawings, line 1 indicates a boundary of an area having a contrast ratio of above 15:1, line 2 indicates an area having a contrast ratio of above 20:1, and line 3 indicates an area having a contrast ratio of above 30:1. From the drawings, it can be seen that the area having the contrast ratio of above 15:1 is widely distributed and a variation in color characteristic is $\Delta u < 0.015$ and $\Delta v < 0.15$, that is, is very small.
- [103]
- [104] Embodiment 2
- [105] A TN-LCD of Embodiment 2 is similar to that of Embodiment 1 except that the in-plane retardation value of the B film included in the integrated O film is 180 nm and the thickness retardation value thereof is 100 nm. The optical characteristic and the color characteristic of the TN-LCD of Embodiment 2 were evaluated.
- [106] The contrast characteristic is shown in FIG. 6 and the color characteristic is shown in FIG. 7. In the drawings, line 1 indicates a boundary of an area having a contrast ratio of above 15:1, line 2 indicates an area having a contrast ratio of above 20:1, and line 3 indicates an area having a contrast ratio of above 30:1. From the drawings, it can be seen that the area having the contrast ratio of above 15:1 is widely distributed and a variation in color characteristic is slightly larger than that of Embodiment 1, but is very small.
- [107]

[108] Comparative Example 1

[109] A TN-LCD of Comparative Example 1 is similar to that of Embodiment 1 except that WV-EA compensation film (made by Fuji Photo Film Co., Ltd) is used as a compensation film. The optical characteristic and the color characteristic of the TN-LCD of Comparative Example 1 were evaluated.

[110] The contrast characteristic is shown in FIG. 8 and the color characteristic is shown in FIG. 9. As can be seen from the FIG. 8, the compensation film manufactured by Comparative example 1 has the same contrast characteristic as the embodiments of the present invention. However, there is a phenomenon that the front color characteristic deteriorates as shown in FIG. 9. That is, in the comparative example, an optical axis separation angle is widely distributed and a variation in color characteristic shown in FIG. 9 is $\Delta v > 0.2$ and $\Delta u > 0.03$, which is larger than those shown in FIGS. 5 and 7. Line 1 varies depending on a viewing angle.

[111] The reason why the color coordinate is shifted is supposed because the negative O film was used. That is, in the negative O film, discotic liquid crystal is used as the liquid crystal included in the O film. As described above, the discotic liquid crystal is more unlikely to be aligned in an alignment axis, compared with nematic liquid crystal used in a positive O film. As a result, an optical axis separation angle occurs.

[112]

Industrial Applicability

[113] Accordingly, the comparative example using the negative O film has a color characteristic inferior to the embodiments of the present invention.

[114] As described above, an integrated O film according to the present invention is manufactured by laminating a positive O film and a negative B film under an optimal condition. Accordingly, it is possible to prevent light leakage in all directions and to manufacture a TN-LCD capable of improving a contrast characteristic, gray scale characteristic and color characteristic by using the integrated O film according to the present invention.

[115] Although the preferred embodiments of the present invention have been disclosed for illustrative purposes, those skilled in the art will appreciate that various modifications, additions and substitutions are possible, without departing from the scope and spirit of the invention as disclosed in the accompanying claims.

[116]

Claims

- [1] An integrated O film comprising a transversely-stretched negative biaxial (B) film, and a positive O film laminated on the transversely-stretched negative B film.
- [2] The integrated O film according to claim 1, wherein an in-plane retardation value of the negative B film is 150 to 250 nm.
- [3] The integrated O film according to claim 2, wherein, a value N_z of the negative B film expressed by Equation 8 is 0.1 to 2.

Equation 8

$$N_z = \left| \left(\frac{n_z - n_y}{n_x - n_y} \right) \right|$$

where, n_x , n_y , and n_z denote refractive indexes of x, y and z directions, respectively.

- [4] The integrated O film according to claim 3, wherein a thickness retardation value of the negative film is -50 to -150 nm.
- [5] The integrated O film according to claim 3, wherein the value N_z of the negative B film is 0.3 to 1.
- [6] The integrated O film according to claim 1, wherein an average tilt angle of the positive O film expressed by Equation 9 is 30° to 50° and a maximum value of the tilt angle is 50° to 90°.

Equation 9

$$\theta_{average} = \frac{\int_0^d \theta(z) dz}{d}$$

where, d denotes a thickness of the film and $\theta(z)$ denotes a tilt angle of the film in a vertical position z.

- [7] The integrated O film according to any one of claims 2 to 6, wherein an in-plane retardation value of the positive O film is 50 to 150 nm.
- [8] The integrated O film according to claim 1, wherein the positive O film includes nematic liquid crystal.
- [9] The integrated O film according to claim 1, further comprising an alignment film interposed between the negative B film and the positive O film.
- [10] The integrated O film according to claim 9, wherein the alignment film is an

acrylic-based alignment film.

- [11] The integrated O film according to claim 9, wherein the alignment film is an optical alignment film having an alignment characteristic by irradiation of polarized ultraviolet rays.
- [12] The integrated O film according to claim 11, wherein the alignment film includes polynorbornene cinnamate or polyimide cinnamate.
- [13] A polarizer plate comprising:
a polarization film; and
an integrated O film laminated on the polarization film,
wherein the integrated O film includes a transversely-stretched negative biaxial (B) film and a positive O film laminated on the transversely-stretched negative B film, and
wherein an in-plane optical axes of the polarization film and the transversely-stretched negative B film are orthogonal to each other.
- [14] The polarizer plate according to claim 13, wherein an in-plane retardation value of the negative B film is 150 to 250 nm.
- [15] The polarizer plate according to claim 14, wherein, a value N_z of the negative B film expressed by Equation 10 is 0.1 to 2.
- Equation 10

$$N_z = \left| \left(\frac{n_z - n_y}{n_x - n_y} \right) \right|$$

where, n_x , n_y , and n_z denote refractive indexes of x, y and z directions, respectively.

- [16] The polarizer plate according to claim 13, wherein an average tilt angle of the positive O film expressed by Equation 11 is 30° to 50° and a maximum value of the tilt angle is 50° to 90°.
- Equation 11

$$\theta_{average} = \frac{\int_0^d \theta(z) dz}{d}$$

where, d denotes a thickness of the film and $\theta(z)$ denotes a tilt angle of the film in a vertical position z.

- [17] A twisted nematic liquid crystal display (TN-LCD) comprising:
a pair of glass plates which face each other;

twisted nematic liquid crystal filled between the glass plates; and polarizer plates attached to the outsides of the glass plates, wherein each of the polarizer plates include a polarization film and an integrated O film laminated on the polarization film, wherein the integrated O film includes a transversely-stretched negative biaxial (B) film and a positive O film laminated on the transversely-stretched negative B film.

[18] The TN-LCD according to claim 17, wherein an in-plane retardation value of the negative B film is 150 to 250 nm.

[19] The TN-LCD according to claim 18, wherein, a value N_z of the negative B film expressed by Equation 12 is 0.1 to 2.
Equation 12

$$N_z = \left| \left(\frac{n_z - n_y}{n_x - n_y} \right) \right|$$

where, n_x , n_y , and n_z denote refractive indexes of x, y and z directions, respectively.

[20] The TN-LCD according to claim 17, wherein an average tilt angle of the positive O film expressed by Equation 13 is 30° to 50° and a maximum value of the tilt angle is 50° to 90°.

Equation 13

$$\theta_{average} = \frac{\int_0^d \theta(z) dz}{d}$$

where, d denotes a thickness of the film and $\theta(z)$ denotes a tilt angle of the film in a vertical position z.

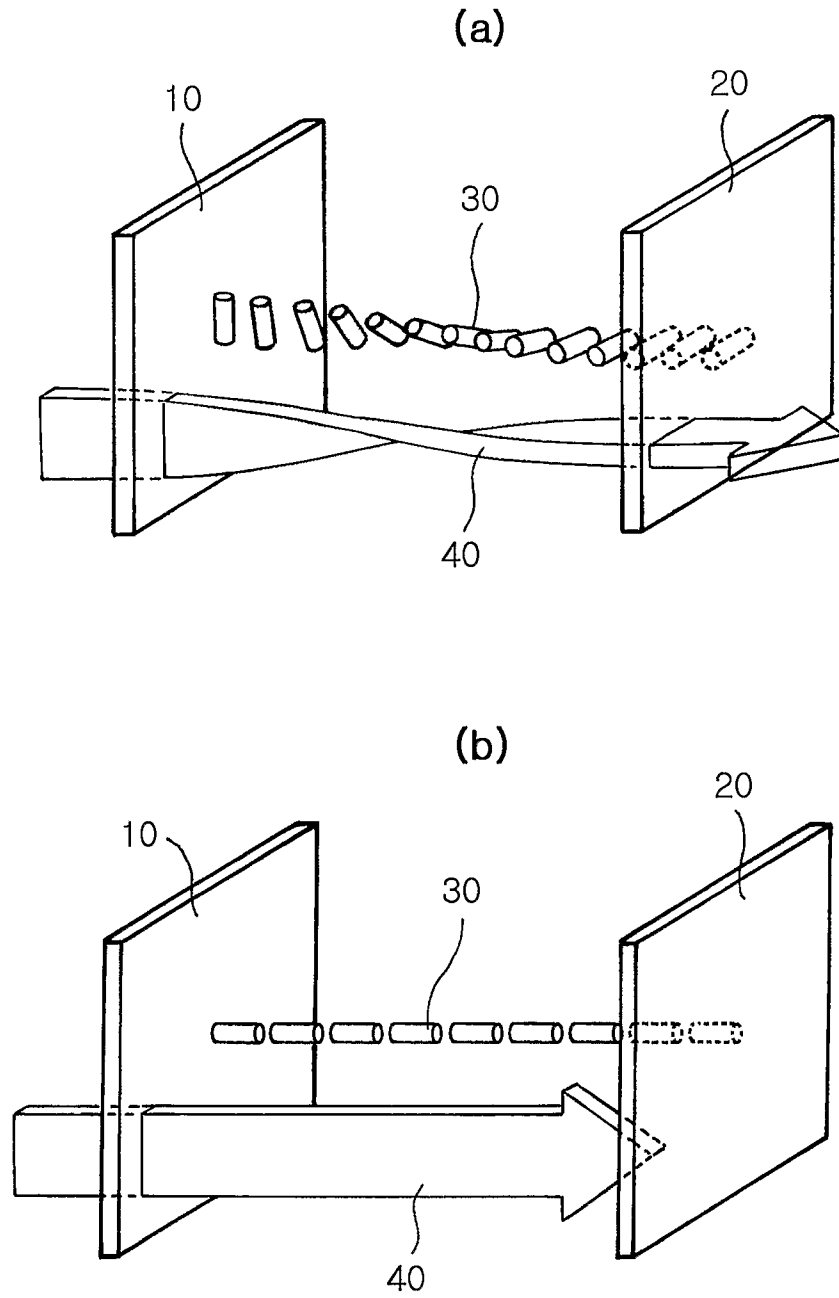

FIG. 1

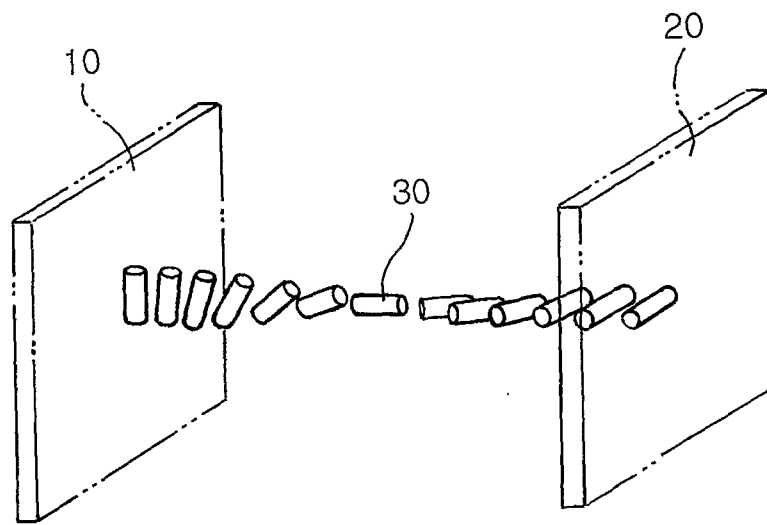

FIG. 2

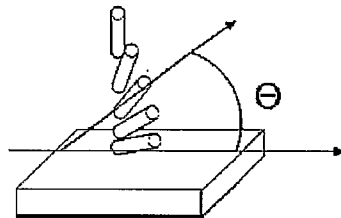

FIG. 3

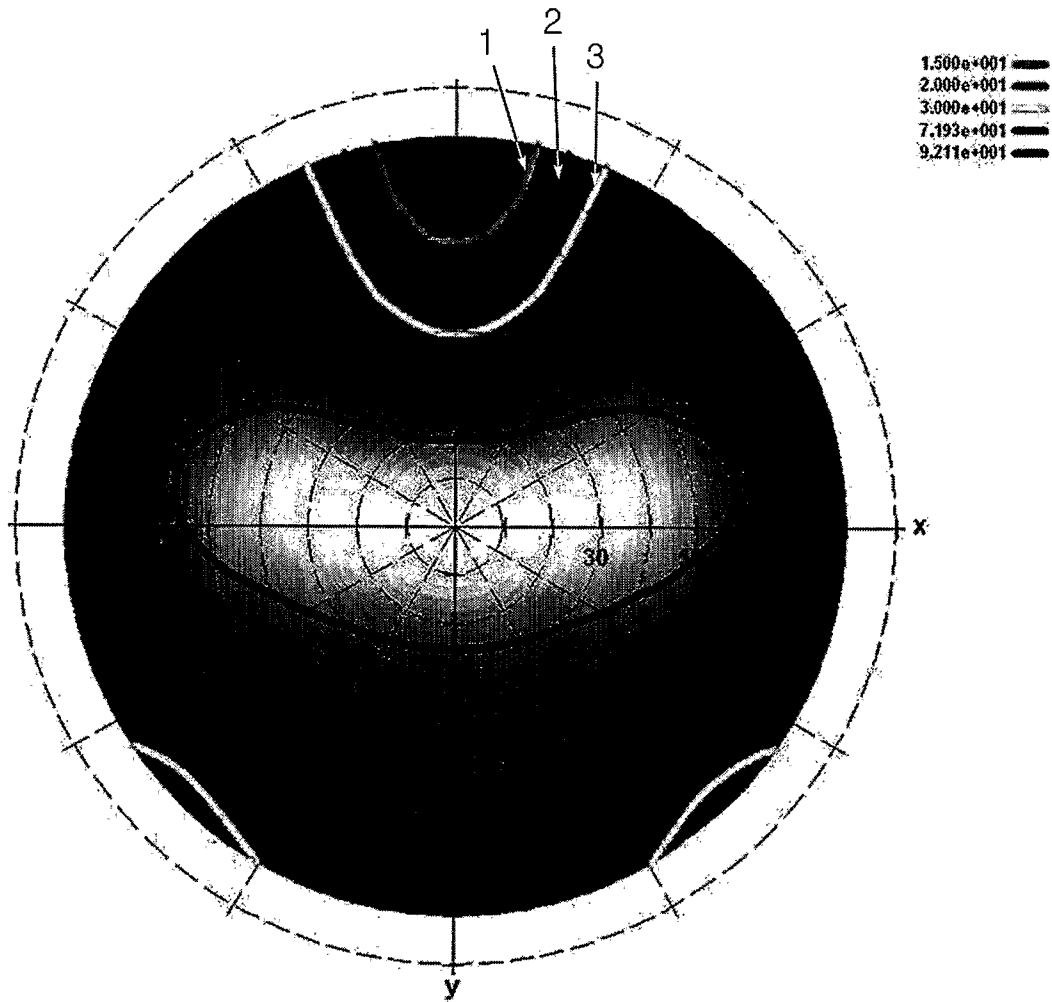

FIG. 4

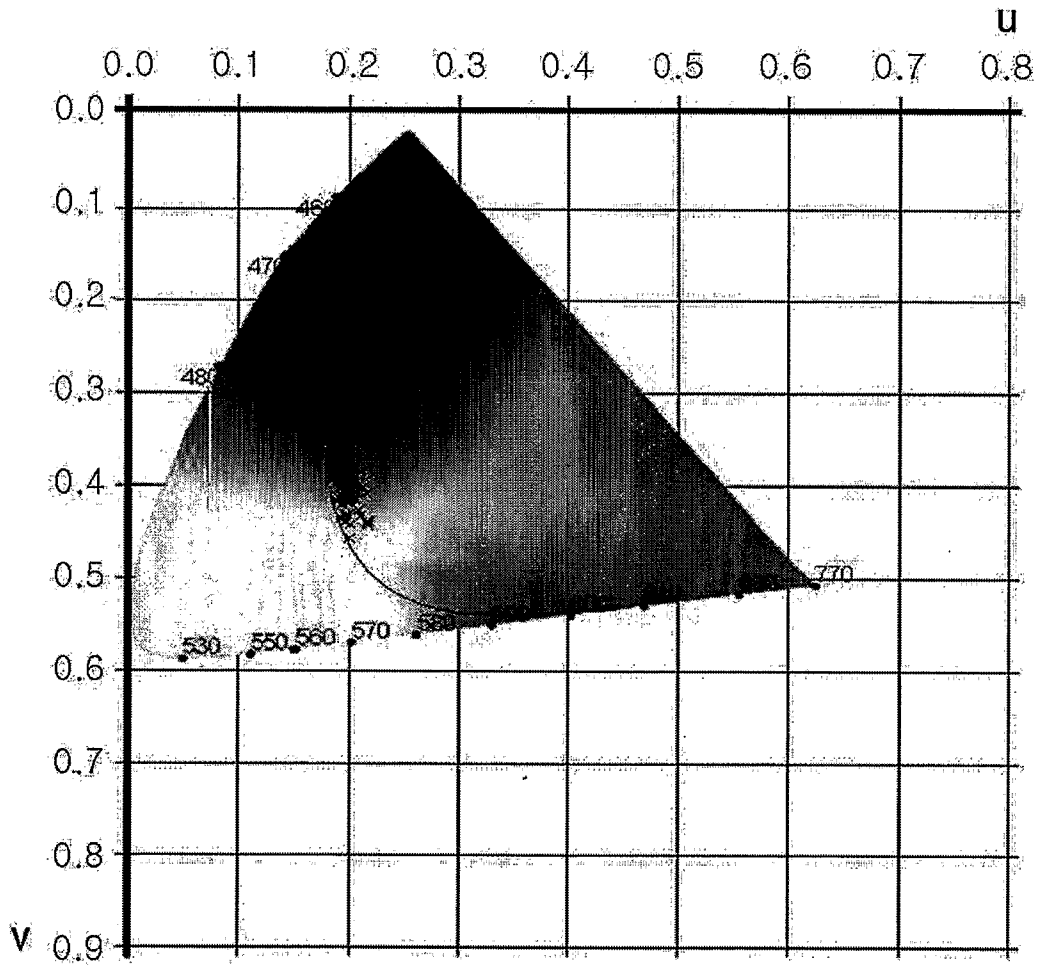

FIG. 5

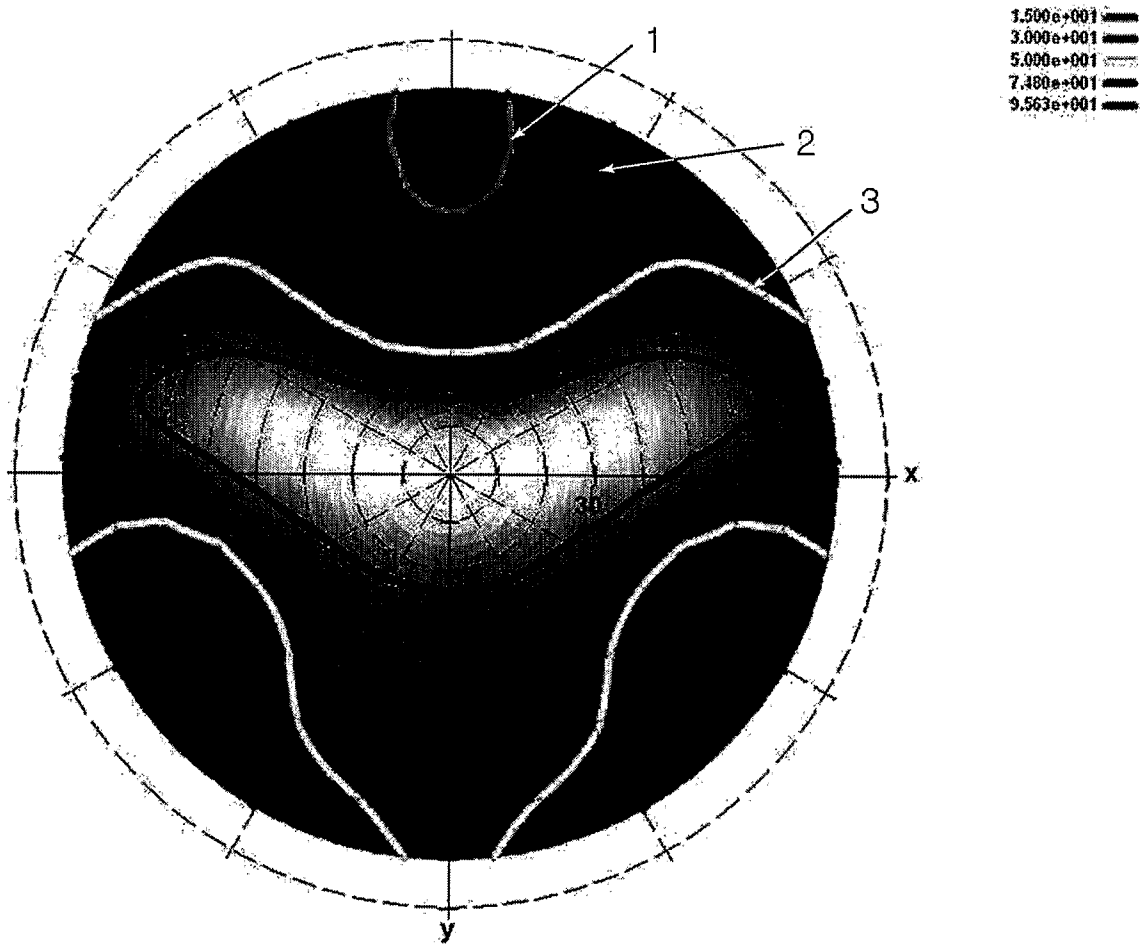

FIG. 6

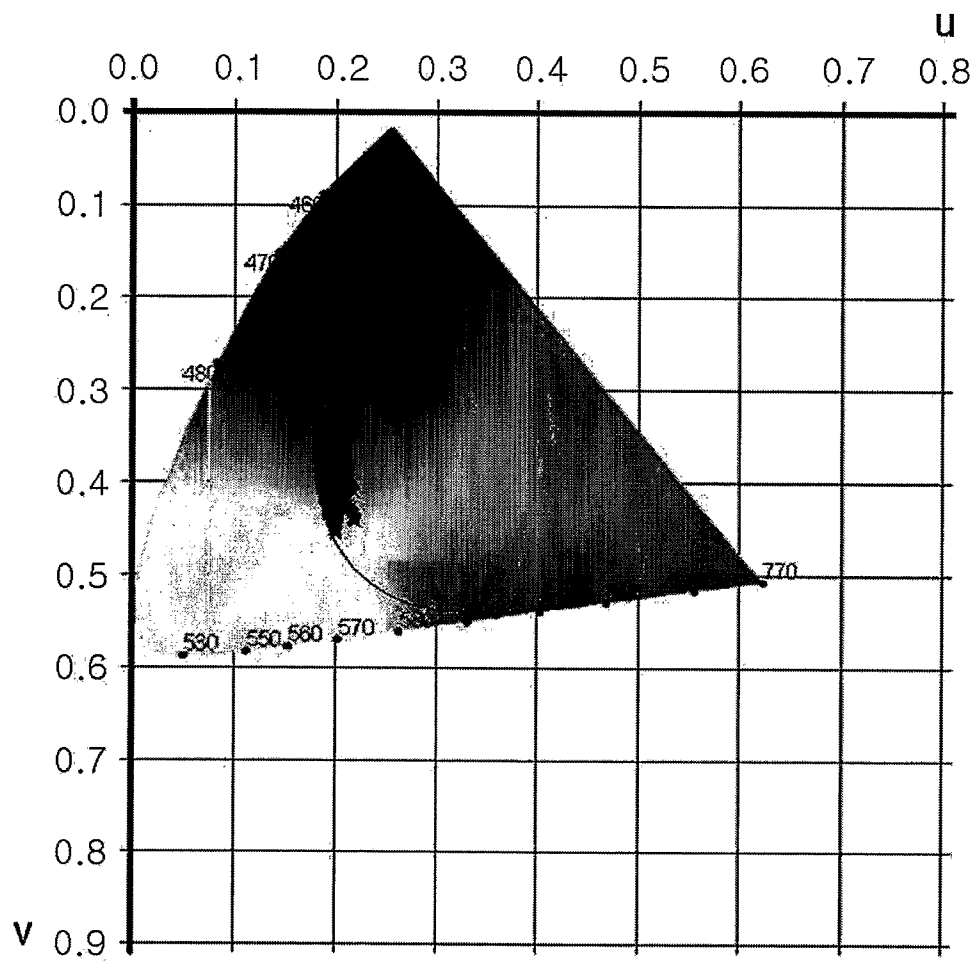

FIG. 7

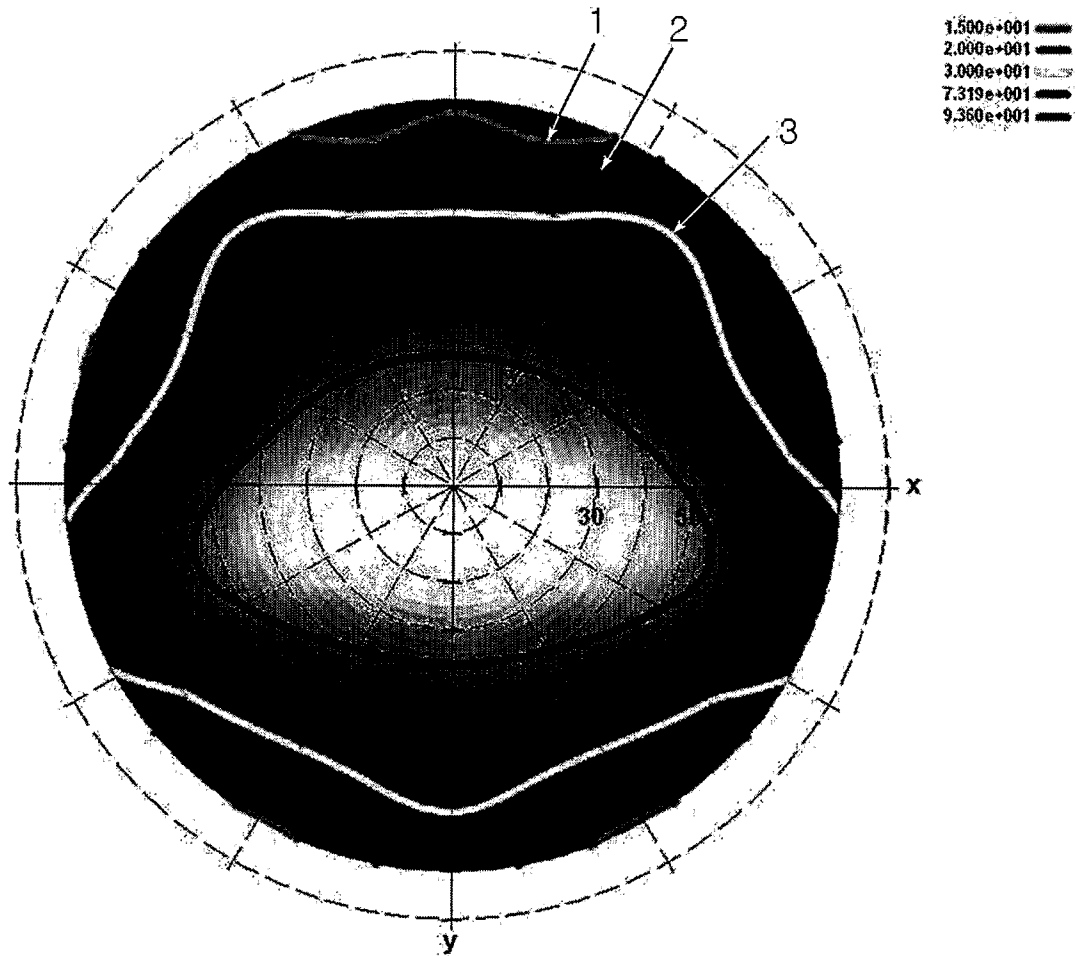

FIG. 8

9/9

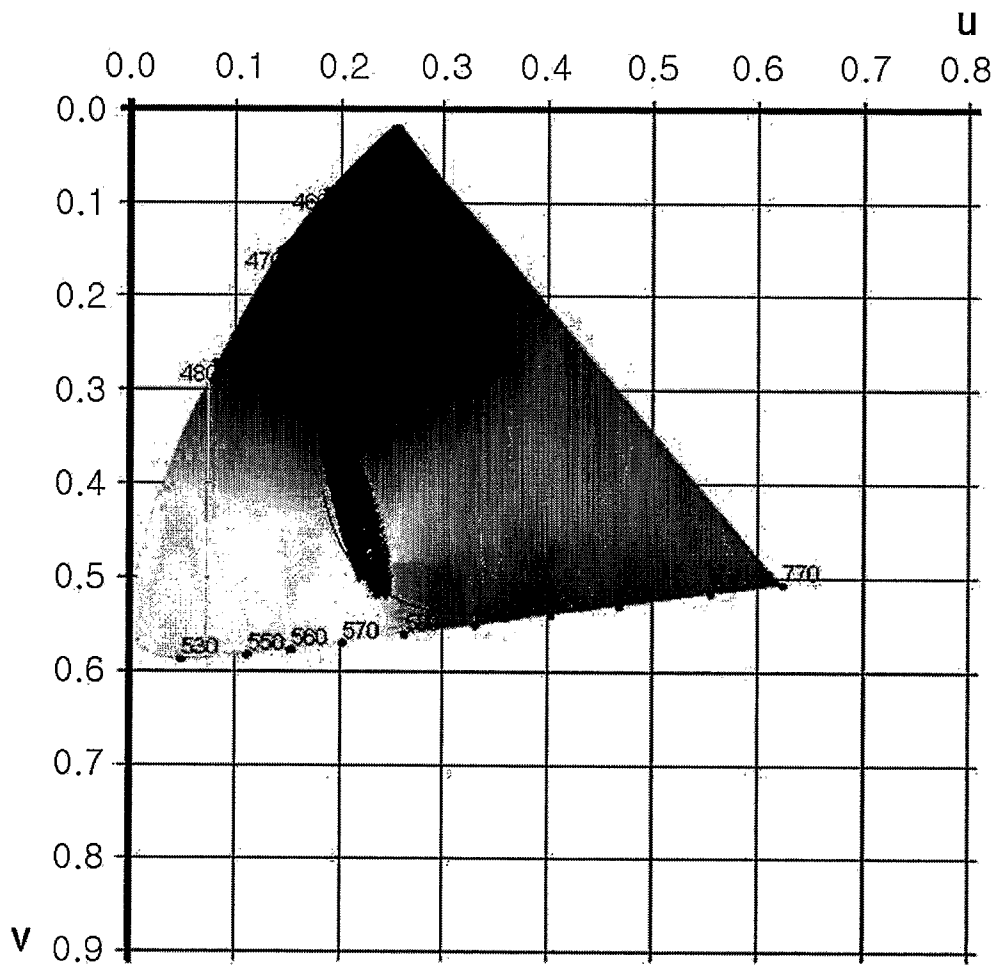

FIG. 9

INTERNATIONAL SEARCH REPORT

International application No.
PCT/KR2007/002733**A. CLASSIFICATION OF SUBJECT MATTER***G02B 5/30(2006.01)i*

According to International Patent Classification (IPC) or to both national classification and IPC

B. FIELDS SEARCHED

Minimum documentation searched (classification system followed by classification symbols)

IPC 8 : G02B

Documentation searched other than minimum documentation to the extent that such documents are included in the fields searched
Korean utility models and applications for Utility Models since 1975Electronic data base consulted during the international search (name of data base and, where practicable, search terms used)
eKIPASS(KIPO internal)**C. DOCUMENTS CONSIDERED TO BE RELEVANT**

Category*	Citation of document, with indication, where appropriate, of the relevant passages	Relevant to claim No.
X	US 2005/0219447A1 (KIM SLANEY et al.) 06 Oct. 2005 See Fig.7(C) and page5.	1-20
A	US5736066A (TAKANOBU NOGUCHI) 07 Apr. 1998 See the claims and abstract.	1-20
A	US2004/0156106A1 (RICHARD C. ALLEN et al.) 12 Aug. 2004 See the claims and abstract.	1-20
A	US2004/0080691A1 (MI XIANG-DONG et al.) 29 Apr. 2004 See the claims and abstract.	1-20

 Further documents are listed in the continuation of Box C. See patent family annex.

* Special categories of cited documents:

"A" document defining the general state of the art which is not considered to be of particular relevance

"E" earlier application or patent but published on or after the international filing date

"L" document which may throw doubts on priority claim(s) or which is cited to establish the publication date of citation or other special reason (as specified)

"O" document referring to an oral disclosure, use, exhibition or other means

"P" document published prior to the international filing date but later than the priority date claimed

"T" later document published after the international filing date or priority date and not in conflict with the application but cited to understand the principle or theory underlying the invention

"X" document of particular relevance; the claimed invention cannot be considered novel or cannot be considered to involve an inventive step when the document is taken alone

"Y" document of particular relevance; the claimed invention cannot be considered to involve an inventive step when the document is combined with one or more other such documents, such combination being obvious to a person skilled in the art

"&" document member of the same patent family

Date of the actual completion of the international search

10 SEPTEMBER 2007 (10.09.2007)

Date of mailing of the international search report

10 SEPTEMBER 2007 (10.09.2007)

Name and mailing address of the ISA/KR

Korean Intellectual Property Office
920 Dunsan-dong, Seo-gu, Daejeon 302-701,
Republic of Korea

Facsimile No. 82-42-472-7140

Authorized officer

KOH, JAE HYUN

Telephone No. 82-42-481-5687



INTERNATIONAL SEARCH REPORT

Information on patent family members

International application No.

PCT/KR2007/002733

Patent document cited in search report	Publication date	Patent family member(s)	Publication date
US20050219447A1	06. 10. 2005	AT303422E	15. 09. 2005
		AU2002366720AA	09. 07. 2003
		DE60205942C0	06. 10. 2005
		DE60205942T2	18. 05. 2006
		EP1453933A1	08. 09. 2004
		EP1453933B1	31. 08. 2005
		JP2005513241A	12. 05. 2005
		KR1020040066159A	23. 07. 2004
		W003054111A1	03. 07. 2003
		US05736066A	07. 04. 1998
DE69534771T2	21. 09. 2006		
EP00712013A2	15. 05. 1996		
EP00712013B1	08. 02. 2006		
EP01329748A2	23. 07. 2003		
EP01329748A3	02. 02. 2005		
JP08190094A	23. 07. 1996		
JP08278406A	22. 10. 1996		
JP08278410A	22. 10. 1996		
KR1019960018621A	17. 06. 1996		
US20040156106A1	12. 08. 2004	CN1748162A	15. 03. 2006
		EP01595171A1	16. 11. 2005
		JP2006517608A	27. 07. 2006
		KR1020050108354A	16. 11. 2005
		US06965474B2	15. 11. 2005
		US2004184150A1	23. 09. 2004
		US2006012879A1	19. 01. 2006
		US2006285041A1	21. 12. 2006
		US6965474B2	15. 11. 2005
		W02004072701A1	26. 08. 2004
US20040080691A1	29. 04. 2004	CN1708704A	14. 12. 2005
		JP2006504146A	02. 02. 2006
		KR1020050074972A	19. 07. 2005
		US6819381B2	16. 11. 2004
		W02004040340A1	13. 05. 2004