



- (51) International Patent Classification:
A47H 19/00 (2006.01)
- (21) International Application Number:
PCT/US2015/038729
- (22) International Filing Date:
1 July 2015 (01.07.2015)
- (25) Filing Language: English
- (26) Publication Language: English
- (30) Priority Data:
62/021,947 8 July 2014 (08.07.2014) US
- (71) Applicant: SYMPLE SOLUTIONS, LLC [US/US]; 230
Concord Street, New Haven, Connecticut 06512 (US).
- (72) Inventor: DEPONTE, Sandra; 230 Concord Street, New
Haven, Connecticut 06512 (US).
- (74) Agents: DELUCA, Peter et al.; Carter, DeLuca, Farrell &
Schmidt LLP, 445 Broadhollow Road, Suite 420, Melville,
New York 11747 (US).
- (81) Designated States (unless otherwise indicated, for every
kind of national protection available): AE, AG, AL, AM,
AO, AT, AU, AZ, BA, BB, BG, BH, BN, BR, BW, BY,
BZ, CA, CH, CL, CN, CO, CR, CU, CZ, DE, DK, DM,
DO, DZ, EC, EE, EG, ES, FI, GB, GD, GE, GH, GM, GT,
HN, HR, HU, ID, IL, IN, IR, IS, JP, KE, KG, KN, KP, KR,
KZ, LA, LC, LK, LR, LS, LU, LY, MA, MD, ME, MG,
MK, MN, MW, MX, MY, MZ, NA, NG, NI, NO, NZ, OM,
PA, PE, PG, PH, PL, PT, QA, RO, RS, RU, RW, SA, SC,
SD, SE, SG, SK, SL, SM, ST, SV, SY, TH, TJ, TM, TN,
TR, TT, TZ, UA, UG, US, UZ, VC, VN, ZA, ZM, ZW.
- (84) Designated States (unless otherwise indicated, for every
kind of regional protection available): ARIPO (BW, GH,
GM, KE, LR, LS, MW, MZ, NA, RW, SD, SL, ST, SZ,
TZ, UG, ZM, ZW), Eurasian (AM, AZ, BY, KG, KZ, RU,

[Continued on next page]

(54) Title: CURTAIN HOLDING DEVICE

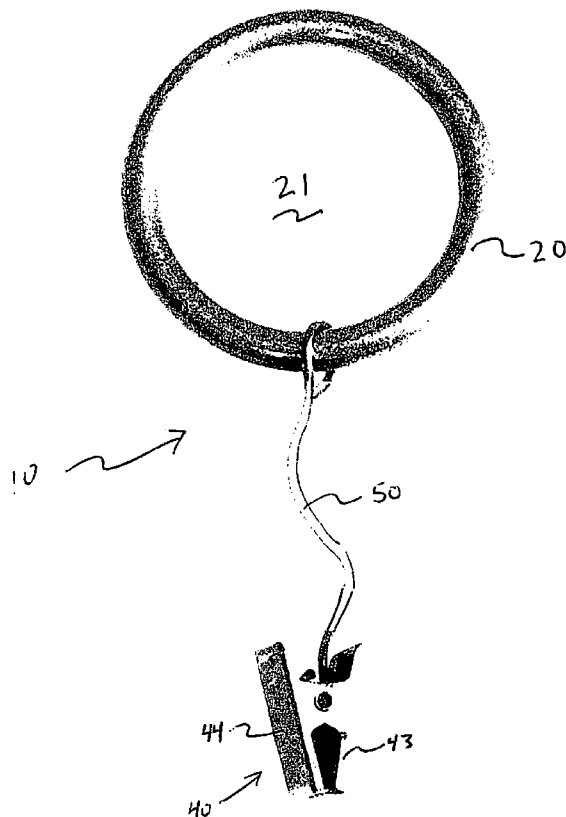

Fig. 1

(57) Abstract: An apparatus for holding curtains includes a retainer and a clip tethered to the retainer. The tether is optionally retractable by a retractor. A decorative element is optionally secured to the retainer. The present disclosure is directed to an apparatus for retaining curtains. The apparatus includes a clip tethered to a retainer. The clip is capable of securing to a curtain. The retainer includes a bore for receiving a curtain therethrough.

TJ, TM), European (AL, AT, BE, BG, CH, CY, CZ, DE, **Published:**
DK, EE, ES, FI, FR, GB, GR, HR, HU, IE, IS, IT, LT, — *with international search report (Art. 21(3))*
LU, LV, MC, MK, MT, NL, NO, PL, PT, RO, RS, SE,
SI, SK, SM, TR), OAPI (BF, BJ, CF, CG, CI, CM, GA,
GN, GQ, GW, KM, ML, MR, NE, SN, TD, TG).

CURTAIN HOLDING DEVICE

TECHNICAL FIELD

[0001] The present disclosure relates generally to a device that retains curtains, draperies, or the like, in a desired orientation (such as, for example in a poufed orientation to create a bishop sleeve or simply in a tied back position) and methods for using the device.

BACKGROUND

[0002] Devices and accessories for drawing back curtains, draperies, or the like not only enable sunlight to enter a room but also may provide a decorative flair to the window treatment or décor of the room.

[0003] Simple holdback devices, such as a tie back, consist of a rope or similar device that is looped around the drape and tied to a wall mounted hook. While these devices provide the ability to adjust the amount the drape is drawn back, the tie back must ultimately be mounted to a wall, prohibiting portability and damaging the wall.

[0004] Therefore, a continuing need exists for an improved device and an improved method for retaining drapes in a desired configuration.

SUMMARY

[0005] The present disclosure is directed to an apparatus for retaining curtains. The apparatus includes a clip tethered to a retainer. The clip is capable of securing to a curtain. The retainer includes a bore for receiving a curtain therethrough.

[0006] In embodiments, the clip is retractably tethered to the retainer by a retractor. The retractor includes a housing and a retractable tether disposed within and extendable from the housing. The retractable tether is capable of being extended in a first direction and retracted in a second direction, and is biased in the second direction by a biasing element. In embodiments, the retractor includes a lock capable of maintaining the tether at a desired length when extended from the retractor.

[0007] In embodiments, the retainer is in mechanical cooperation with an end of the retractable tether and the clip disposed on an outer surface of the housing of the retractor. In other embodiments, the retainer is in mechanical cooperation with the housing of the retractor and the clip disposed on an end of the retractable tether.

[0008] In aspects of the present disclosure, the retainer is a toroid.

[0009] In embodiments, a decorative element is secured to the retainer.

[0010] In embodiments, the retainer includes first and second jaw members movable from a first open position to a second approximated position. In the approximated position, the first and second jaw members of the retainer form a bore through which a curtain may be received. The first and second jaw members of the retainer are rotatably affixed on a first end and capable of movement relative to each other. In embodiments, a second end of the first jaw member of the retainer is releasably coupled to a second end of the second jaw member of the retainer while first and second jaw members of the retainer are in an approximated position. In embodiments, a biasing element biases the first and second jaw members of the retainer toward the approximated position.

[0011] In embodiments, the retainer includes an elongate body having a first and second end. The retainer is affixed to an end of the retractable cord between the first and

second ends of the elongate body. The first end of the elongate body is releasably coupled to the second end of the elongate body to define a bore through which a curtain can be placed. In embodiments, the first end of the elongate body is releasably coupled to the second end of the elongate body by at least one magnet or by hook and loop fastener.

[0012] A method for holding curtains provided in accordance with the present disclosure includes positioning a curtain through a bore defined through a retainer at a first location on a curtain, elevating the retainer to an elevated height that allows curtain material to billow over the retainer, and securing a clip that is tethered to the retainer to the curtain at a second location on the curtain vertically above the first location to maintain the retainer at the elevated height. In embodiments, the clip is retractably tethered to the retainer and the method further includes extending a retractable tether from a retractor housing, wherein the retractable tether is biased by a biasing element to pull the clip towards the retainer.

BRIEF DESCRIPTION OF THE DRAWINGS

[0013] The above and other aspects, features, and advantages of the present disclosure will become more apparent in light of the following detailed description when taken in conjunction with the accompanying drawings in which:

[0014] FIG. 1 illustrates an apparatus in accordance with the present disclosure;

[0015] FIGS. 2A, 2B and 2C illustrate the steps of a method of using an apparatus in accordance with the present disclosure;

[0016] FIG. 3 illustrates an apparatus in accordance with another embodiment of the present disclosure;

[0017] FIG. 4 illustrates the apparatus of FIG. 3 with the tether in an extended position;

[0018] FIG. 5 illustrates an apparatus in accordance with another embodiment of the present disclosure;

[0019] FIG. 6 is a perspective view of another apparatus for holding a curtain provided in accordance with the present disclosure shown in an open position;

[0020] FIG. 6A is a perspective view of the apparatus of FIG. 6 shown in an approximated position;

[0021] FIG. 7 is a perspective view of another apparatus for holding a curtain provided in accordance with the present disclosure shown in an open position;

[0022] FIG. 7A is a perspective view of the apparatus of FIG. 7 shown in an approximated position;

[0023] FIG. 8 illustrates an apparatus in accordance with another embodiment of the present disclosure;

[0024] FIG. 9 illustrates the apparatus of FIG. 8 installed on a curtain; and

[0025] FIGS. 10A, 10B, 10C, and 10D illustrate exemplary embodiments of decorative elements useful in connection with the embodiment of FIG. 8.

DETAILED DESCRIPTION

[0026] Embodiments of the present disclosure are now described in detail with reference to the drawings in which like reference numerals designate identical or corresponding elements in each of the several views. In the drawings and in the

description that follows, terms such as front, rear, upper, lower, top, bottom, and similar directional terms are used simply for convenience of description and are not intended to limit the disclosure. In the following description, well-known functions or constructions are not described in detail to avoid obscuring the present disclosure in unnecessary detail.

[0027] FIG. 1 illustrates a curtain holding device 10 provided in accordance with the present disclosure that generally includes a retainer 20 and a clip 40 tethered to retainer 20 by tether 50. Retainer 20 includes a bore 21 defined therethrough. As illustrated in FIG. 1, retainer 20 is generally shown as being toroidal, although other configurations are also contemplated, such as square, rectangular, or the like. Bore 21 is configured and/or dimensioned to enable a curtain “C” to be advanced therethrough. Retainer 20 can be made of any material, including metal, plastic, rubber, and the like. In embodiments, the material of construction from which retainer 20 is made will have sufficient frictional engagement with a curtain positioned through bore 21 to maintain retainer 20 at a desired position on the curtain.

[0028] Clip 40 may be any type of clip within the purview of those skilled in the art, such as, for example, any articulating clip, such as an alligator clip. As illustrated in the exemplary embodiment of FIG. 1, clip 40 includes first and second jaw members 43, 44 capable of movement relative to each other. A biasing element (not shown) biases first and second jaw members 43, 44 toward a closed position.

[0029] Tether 50 can be a cord, yarn, string or narrow length of fabric. In embodiments, tether 50 is made of an elastic material, thereby biasing clip 40 toward retainer 20 when a curtain is positioned through bore 21 and clip 40 is attached to the curtain at a position remote from retainer 20. The length of tether 50 is not critical, and

can range, for example, from about 1 inch to about 30 inches, in other embodiments, from about 3 inches to about 20 inches, in yet other embodiments from about 6 inches to about 18 inches.

[0030] In operation, curtain holding device 10 retains a curtain in a desired configuration, such as, for example in a poufed orientation to create a bishop sleeve or simply in a tied back position. Initially, curtain “C” is positioned through bore 21 of retainer 20 at a first location on the curtain as shown in FIG. 2A. Retainer 20 is then elevated to an elevated height that allows curtain material to billow over the retainer as shown in FIG. 2B. Clip 40 is then secured to the curtain at a second location on the curtain vertically above the first location on the curtain to maintain retainer 20 at the elevated height via tether 50 as shown in FIG. 2C. As will be appreciated, when in place, retainer 20 is not visible beneath the billowed or poufed fabric of the curtain.

[0031] Turning now to FIGS. 3 and 4, a curtain holding device 100 provided in accordance with another embodiment of the present disclosure generally includes a retainer 120, a retractor 130, and a clip 140 retractably tethered to retainer 120 by tether 150. Retractor 130 can be any type of retractor within the purview of those skilled in the art, such as retractor reels of the type known for holding keys, badges and the like. Suitable retractor devices are disclosed, for example in U.S. Patent Nos. 7,007,882, 6,290,158, 6,073,875, and 6,364,237, the entire disclosure of each of which is incorporated herein by this reference.

[0032] In embodiments, retractor 130 includes a ratchet mechanism so that the tether can be locked at a desired length when extended. Such retractable reels are typically lockable through a mechanism exerting some amount of force on the reel to prevent the

tether from being retracted and therefore keep the tether at a desired length. Suitable lockable retractor devices are disclosed, for example in U.S. App. Pub. No. 2005/0011982 and U.S. Patent Nos. 6,199,785; 6,019,304; 7,364,109, and 7,384,013, the entire disclosure of each of which is incorporated herein by this reference.

[0033] As illustrated in the exemplary embodiment of FIG. 3, retractor 130 includes a housing 131 to which clip 140 is affixed. Although shown as being rigidly affixed to an outer surface of housing 131, it is also contemplated that clip 140 may be affixed to an outer surface of housing 131 such that clip 140 is capable of swiveling 360 degrees about a center region of the outer surface of housing 131.

[0034] Retainer 120 includes a lug 122 that is affixed to an outer surface thereof. As illustrated in FIG. 3, lug 122 is integral to retainer 120, although other configurations are also contemplated.

[0035] While not explicitly shown in the drawings, those skilled in the art will appreciate that the internal structure of retractor 130 includes a reel (not shown) rotatably supported within the interior of housing 131 and around which tether 150 can be wrapped. A biasing element (not shown) is affixed to housing 131 on a first end and to the reel (not shown) on a second end, thereby biasing the reel towards a direction that winds tether 150 about the reel. Tether 150 is secured on a first end to the reel (not shown) and may be any extended from and retracted back into housing 131. End stop 136 is secured to a second end of tether 150 and is configured and/or dimensioned to prohibit tether 150 from being wound fully within housing 131. A second end of end stop 136 includes a bore 137 defined through an upper and lower surface thereof. A ring

138 is advanced within bore 137 and is configured and/or dimensioned to engage lug 122 such that retractor 130 and retainer 120 are coupled.

[0036] In operation, curtain holding device 100 functions in the manner described above with respect to curtain holding device 10 to retain a curtain in a poufed configuration or in a tied back position. Initially, curtain “C” is positioned through bore 121 of retainer 120 at a first location on the curtain. Retainer 120 is then elevated to an elevated height that allows curtain material to billow over the retainer. Retractable tether 150 is then extended from retractor 130 and clip 140 is secured to the curtain at a second location on the curtain vertically above the first location on the curtain to maintain retainer 120 at the elevated height via retractable tether 150.

[0037] In the alternative embodiment of curtain holding device 200 shown in FIG. 5, retractor 230 is affixed to retainer 220 and clip 240 is secured to an end of retractable tether 250. In operation, curtain holding device 200 functions in the manner described above with respect to curtain holding devices 10, 100 to retain a curtain in a poufed configuration. Initially, curtain “C” is positioned through bore 221 of retainer 220 at a first location on the curtain. Retainer 220 is then elevated to an elevated height that allows curtain material to billow over the retainer. Retractable tether 250 is then extended from retractor 230 by pulling on clip 240. Clip 240 is then secured to the curtain at a second location on the curtain vertically above the first location on the curtain to maintain retainer 220 at the elevated height via retractable tether 250.

[0038] Another embodiment of a retainer 320 which can be used with any of curtain holding devices 10, 100, 200 is illustrated in FIGS. 6 and 6A. Retainer 320 includes first and second jaw members 301, 302 capable of movement relative to each other. First and

second jaw members 301, 302 are rotatably affixed at a first end using any suitable means, such as a pin 304. A second end includes a lock 303 thereby retaining first and second jaw members 301, 302 in an approximated position. Lock 303 may be any suitable lock such as magnets, pins, hook and loop, etc.

[0039] In operation, a curtain holding device including retainer 320 functions in the manner described above with respect to curtain holding devices 10, 100, 200 to retain a curtain in a poufed configuration or in a tied back position. Retainer 320 is utilized by moving first and second jaw members 301, 302 into an open position and while in the open position, first and second jaw members 301, 302 are positioned around a curtain at a first position on the curtain. First and second jaw members 301, 302 are then moved into an approximated position, to surround the curtain within bore 321 and locked in the approximated position. Retainer 320 is then elevated to an elevated height that allows curtain material to billow over the retainer. A tethered clip can then be used to secure retainer in the elevated height as described hereinabove.

[0040] Another embodiment of a retainer 420 which can be used with any of curtain holding devices 10, 100, 200 is illustrated in FIGS. 7 and 7A. Retainer 420 includes an elongate body 401 having first and second ends. Elongate body 401 may be constructed of any suitable material being having compliant properties, e.g., rope, fabric, composites, etc. Elongate body 401 is affixed to retractor 130 at a location between the first and second ends. A lock 403 is disposed on the first and second ends of elongate body 401 such that elongate body 401 may be locked into a loop defining a bore 421 capable of retaining a curtain therein. Lock 403 may be any suitable lock such as magnets, pins, hook and loop, etc. It is also contemplated that the first and second ends of elongate

body 401 may be tied together, thereby locking elongate body into a loop including a bore 421 capable of retaining a curtain "C", drape, or the like therein.

[0041] In operation, a curtain holding device including retainer 420 functions in the manner described above with respect to curtain holding devices 10, 100, 200 to retain a curtain in a poufed configuration or in a tied back position. Retainer 420 is utilized by wrapping elongate body 401 around a curtain at a first location on the curtain to surround the curtain within bore 421 and locked in this position using lock 403. Retainer 420 is then elevated to an elevated height that allows curtain material to billow over the retainer. A tethered clip can then be used to secure retainer in the elevated height as described hereinabove.

[0042] In embodiments, the curtain holding device of the present disclosure includes a decorative element for aesthetically embellishing a curtain. As seen in the illustrative embodiment of FIG. 8, curtain holding device 500 includes a retainer 520 and a clip 540 tethered to retainer 520 by tether 550 which is secured to lug 522. Retainer 520 includes a bore 521 defined therethrough as in previous embodiments and decorative element 590 secured thereto.

[0043] Decorative element 590 can be secured to retainer 520 in any manner within the purview of those skilled in the art such as, for example, by the use of a magnet, adhesive, welding, hook and loop fastener, a loop of wire, or a mechanical fastener (e.g., a screw, tack, staple, or the like). Those skilled in the art will appreciate that certain securement techniques will allow the decorative element to be changed when desired, while other securement techniques will result in permanent attachment. In the exemplary embodiment shown in FIG. 8, decorative element 590 is secured to retainer 520 using

screw 560, which allows for decorative element 590 to be removed (due to the accessibility of screw head 562) and replaced as desired.

[0044] Decorative element 590 may include a standoff 570 to create a space between retainer 520 and decorative element 590 to accommodate a curtain “C” therein, so that decorative element 590 is visible and provides an aesthetically pleasing embellishment to the curtain, while maintaining retainer 520 hidden from view when curtain holding device 500 is installed as shown in FIG. 9.

[0045] Decorative element 590 may be made from any suitable material, such as textiles, plastics, metals, ceramics, or the like, or any combination of materials. In embodiments, the decorative element may include jewelry elements, such as decorative stones, for example diamonds, rhinestones, pearls, or the like, or a precious metal, for example, silver, gold, platinum, or the like.

[0046] Decorative element 590 may be of any desired, aesthetically pleasing design, such as may be achieved by a combination of any artistic features, such as shape, coloring, and/or texture. For example, the decorative element may be a disc which is adorned by a decorative motif or design on one side. An illustrative example of a domed, disc-shaped decorative element 590A is shown in FIG. 10C. Alternatively, the decorative member may be in the shape of a flower, including but not limited to fabric flowers, plastic molded flowers, or even fresh flowers. An illustrative example of a flower decorative element 590C is shown in FIG. 10C. An illustrative example of a decorative element 590B in the form of holly as shown in FIG. 10B is especially useful in embodiments where the securement technique employed allows the decorative element to be changed seasonally or for holidays. Alternatively, the decorative member may be in

the shape of an ornamental bow, such as, for example, a rosette bow, double loop rosette bow, bow and flower, tri-color rosette (requires three coordinating fabrics), or combinations and variations of the above-mentioned ornamental bows. An illustrative example of a decorative element 590D in the form of a bow is shown in FIG. 10D. Those skilled in the art reading this disclosure will readily envision other aesthetically pleasing designs for decorative element 590.

[0047] Persons skilled in the art will understand that the structures and methods specifically described herein and shown in the accompanying figures are non-limiting exemplary embodiments, and that the description, disclosure, and figures should be construed merely as exemplary of particular embodiments. It is to be understood, therefore, that the present disclosure is not limited to the precise embodiments described, and that various other changes and modifications may be effected by one skilled in the art without departing from the scope or spirit of the disclosure. Additionally, the elements and features shown or described in connection with certain embodiments may be combined with the elements and features of certain other embodiments without departing from the scope of the present disclosure, and that such modifications and variations are also included within the scope of the present disclosure. Accordingly, the subject matter of the present disclosure is not limited by what has been particularly shown and described.

WHAT IS CLAIMED IS:

1. An apparatus for holding curtains, comprising:
a retainer defining a bore capable of receiving a curtain;
a clip capable of securing to a curtain; and
a tether connecting the retainer to the clip.
2. The apparatus according to claim 1 further comprising a retractor, the retractor biasing the clip toward the retainer.
3. The apparatus according to claim 1 wherein the tether is retractable into a retractor.
4. The apparatus according to claim 2 wherein the clip is mounted on the retractor.
5. The apparatus according to claim 2 wherein the retractor includes a lock capable of maintaining the tether at a desired length.
6. The apparatus according to claim 1 wherein the retainer is a toroid.

7. The apparatus according to claim 1 wherein the retainer comprises first and second jaw members rotatably affixed on a first end and capable of movement relative to each other, wherein the first jaw member is releasably coupled to the second jaw member on a second end while in an approximated position.

8. The apparatus according to claim 1 wherein the retainer comprises an elongate body having a first and second end, wherein the first end of the elongate body is releasably coupled to the second end of the elongate body.

9. The apparatus according to claim 1 further comprising a decorative element attached to the retainer.

10. A method of holding a curtain, comprising:
positioning a curtain through a bore defined through a retainer at a first location on a curtain,
elevating the retainer to an elevated height that allows curtain material to billow over the retainer, and
securing a clip that is tethered to the retainer to the curtain at a second location on the curtain vertically above the first location to maintain the retainer at the elevated height.

11. The method according to claim 10 wherein the clip is retractably tethered to the retainer and the method further comprises extending a retractable tether from a retractor housing, wherein the retractable tether is biased by a biasing element to pull the clip towards the retainer.

12. The method according to claim 10 wherein positioning the curtain through a bore comprises placing a first and second jaw member of a retainer in an open position, advancing the retainer over the curtain, and placing the first and second jaw members of the retainer in an approximated position.

13. The method according to claim 10 wherein positioning the curtain through a bore comprises wrapping an elongate body around the curtain, and affixing the first end of the elongate body to the second end of the elongate body thereby retaining a curtain therein.

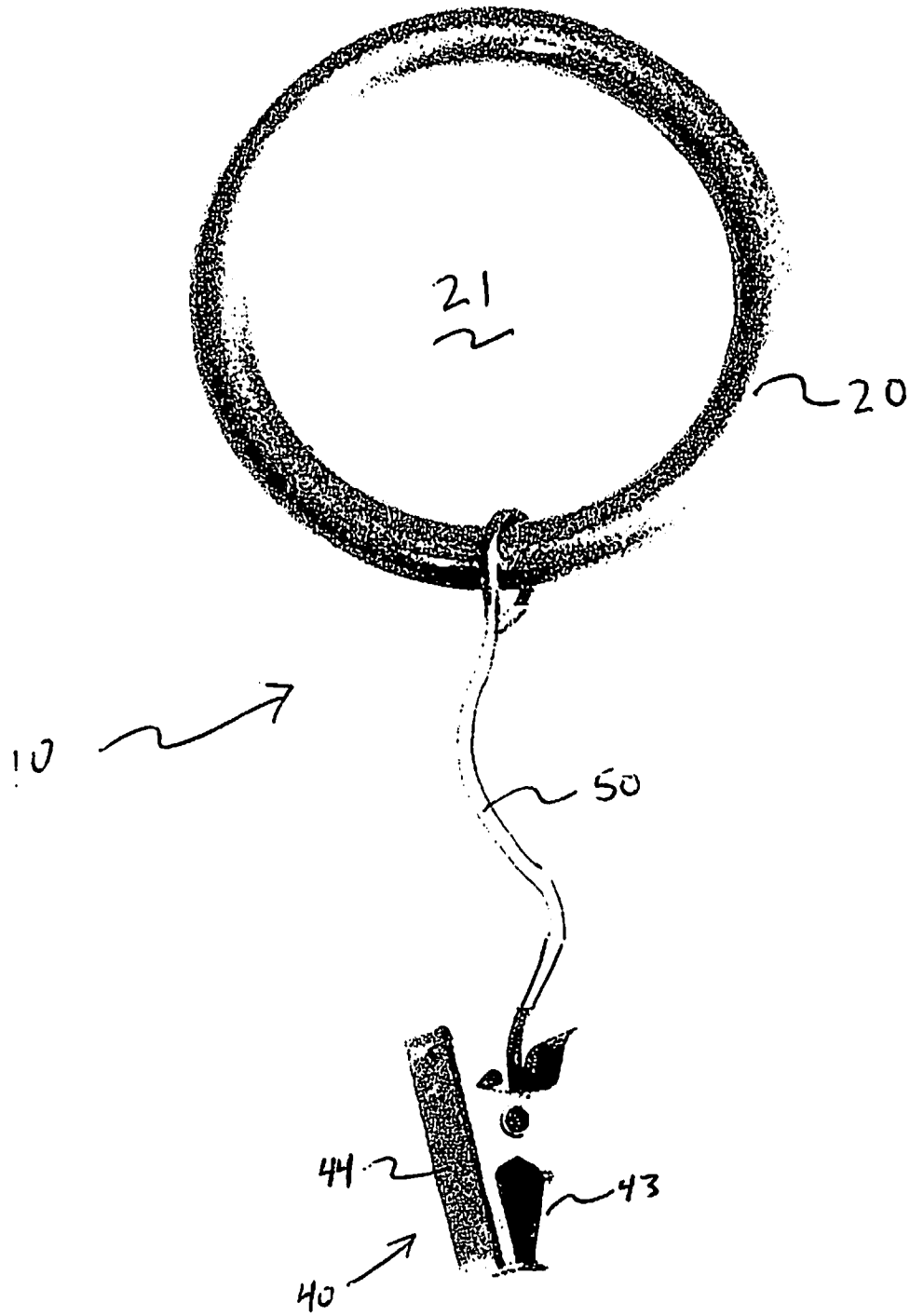

Fig. 1

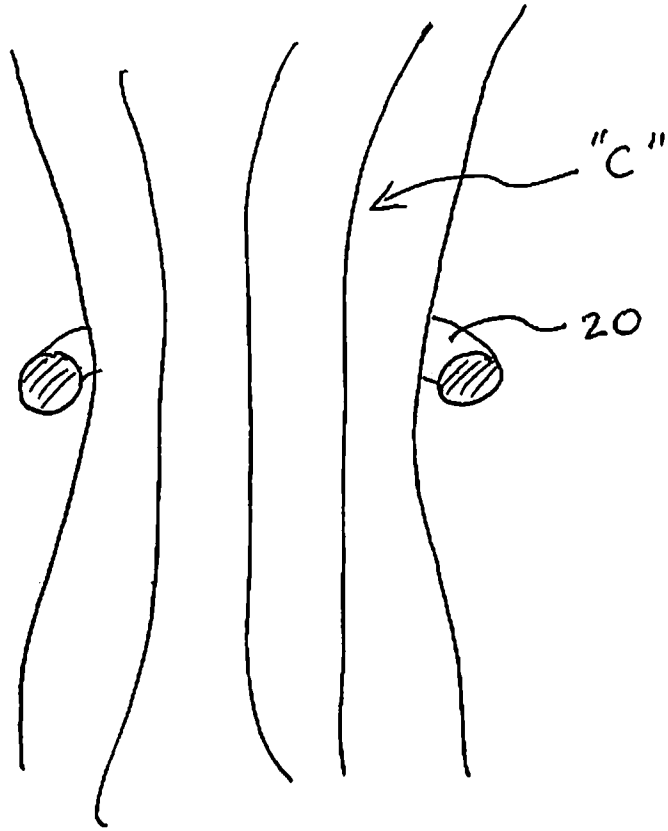

Fig 2A

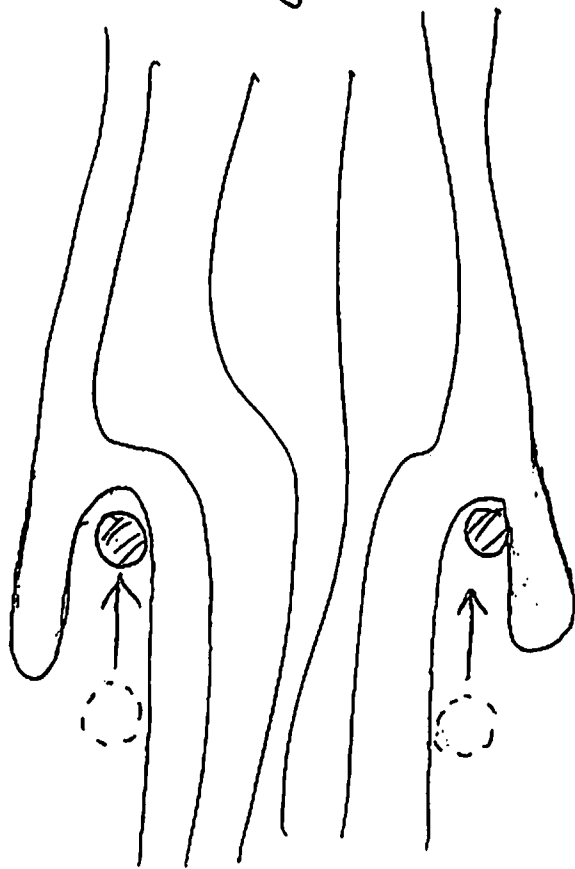

FIG. 2B

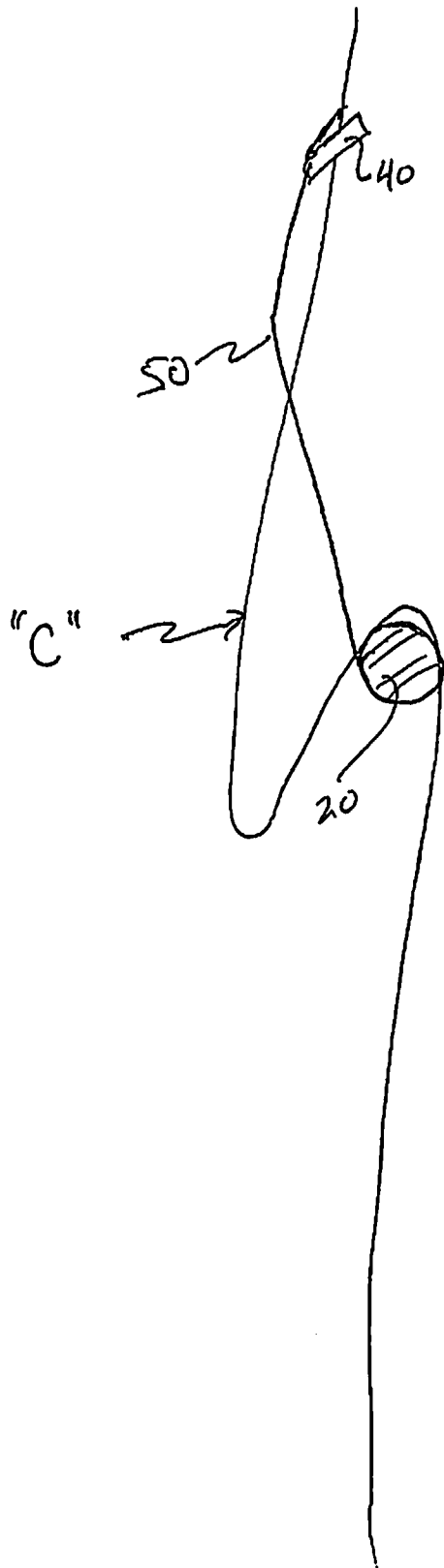

Fig. 2C

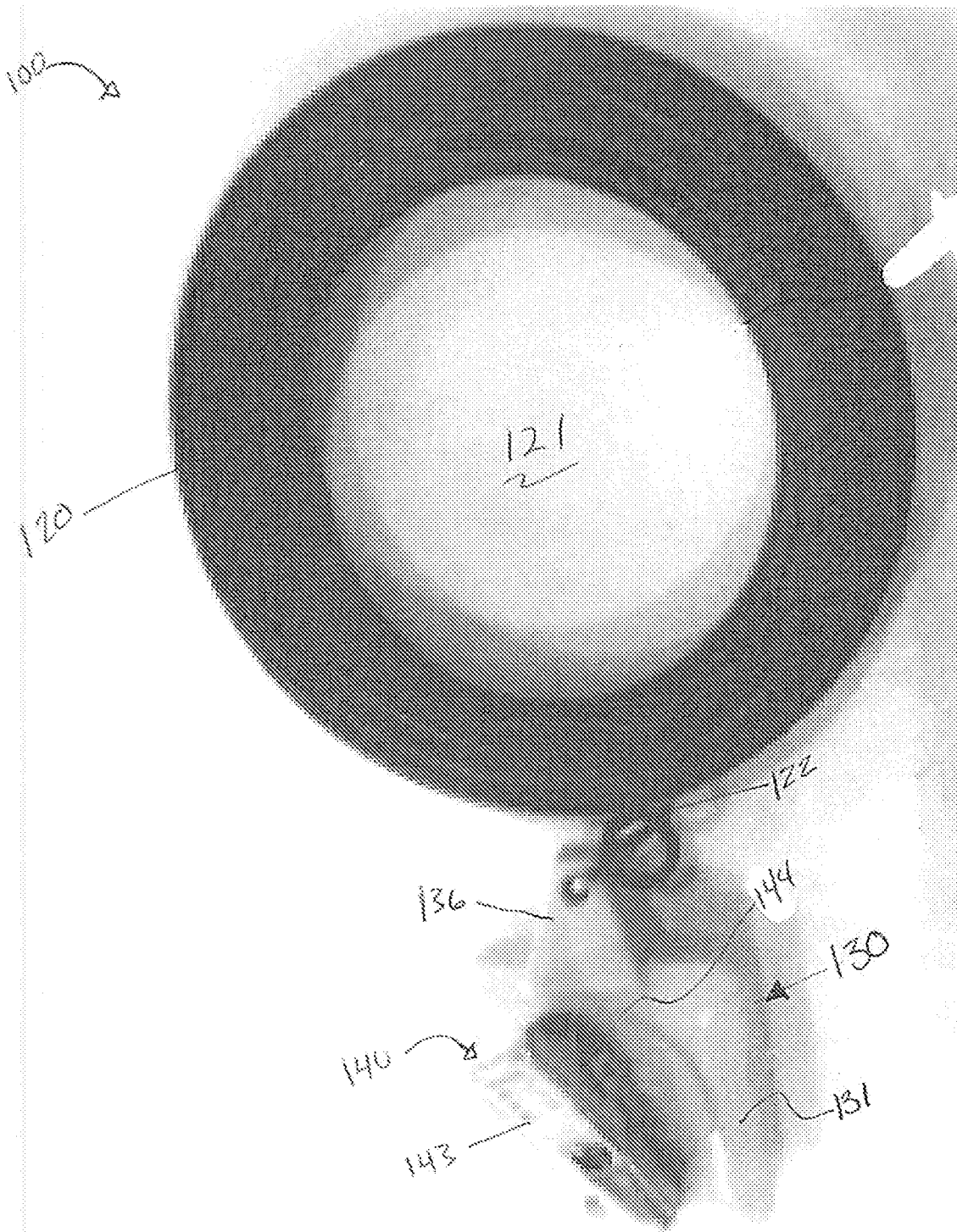

FIG. 3

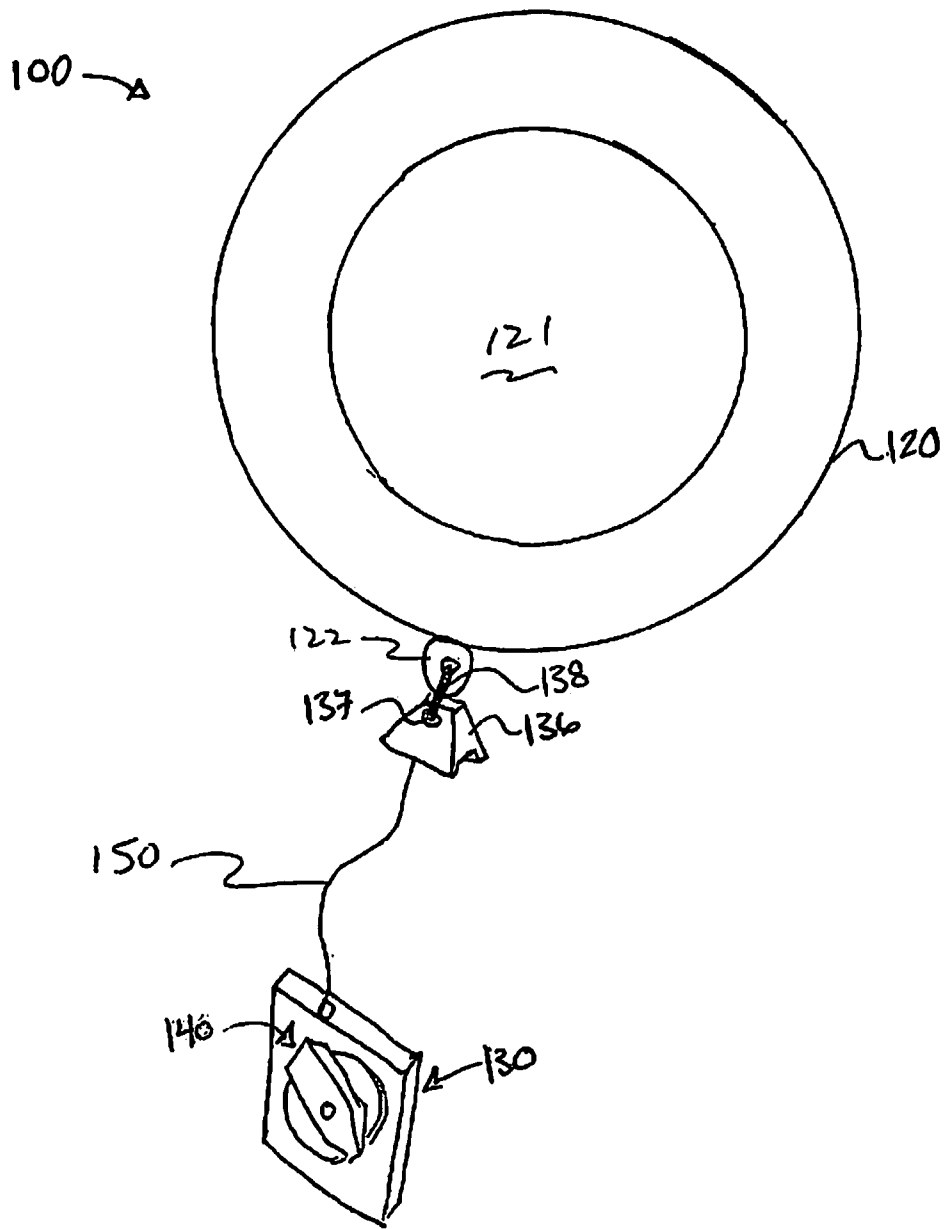

FIG. 4

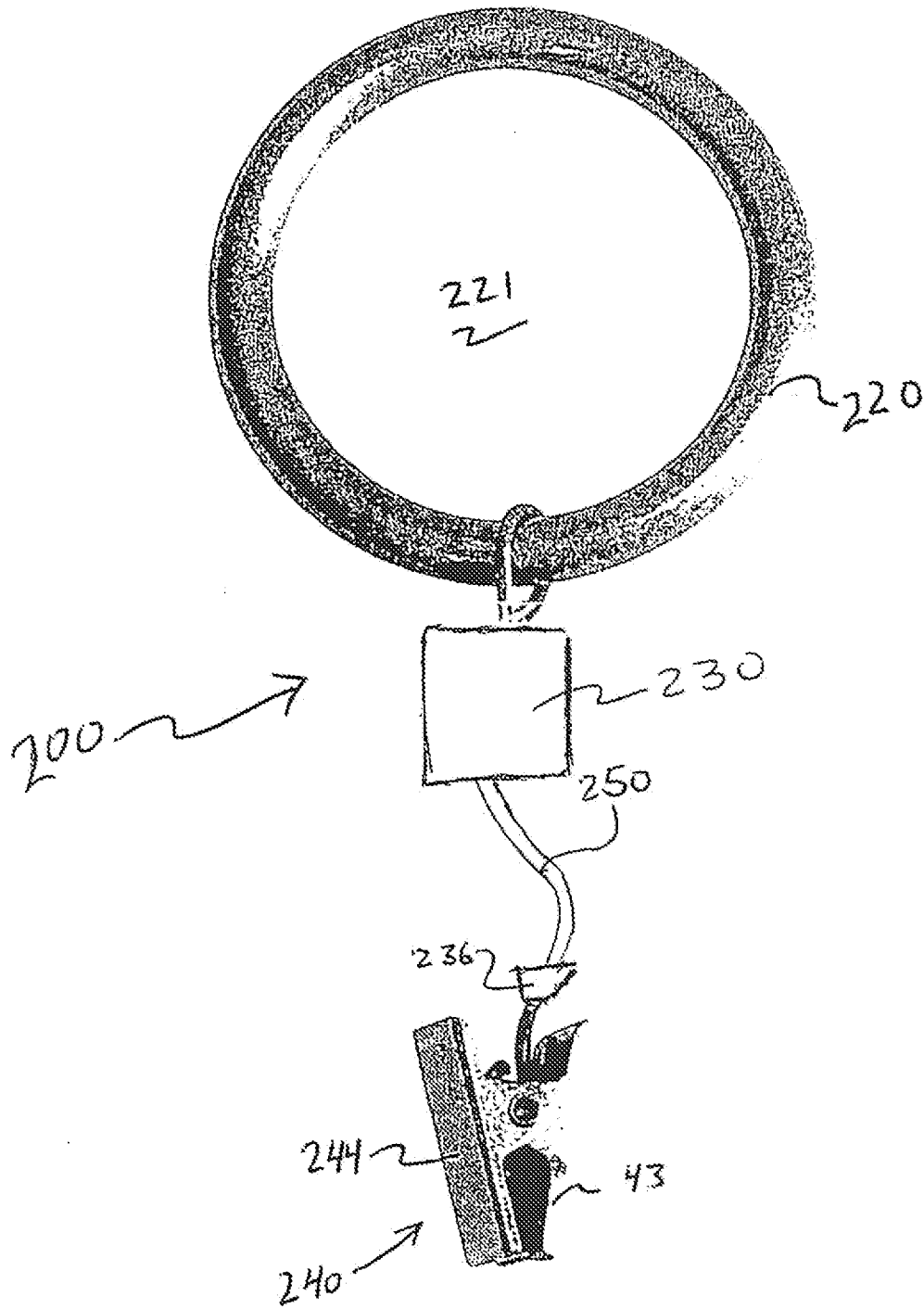

Fig. 5

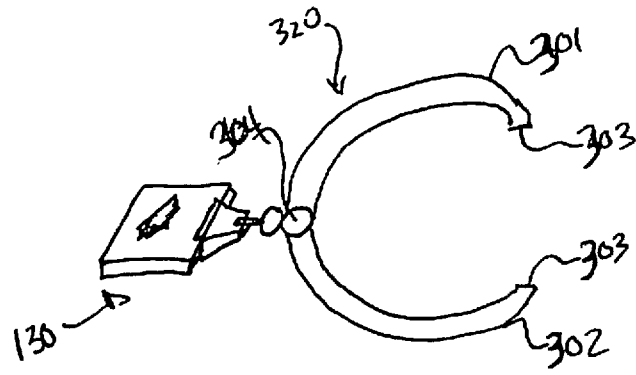

FIG. 6

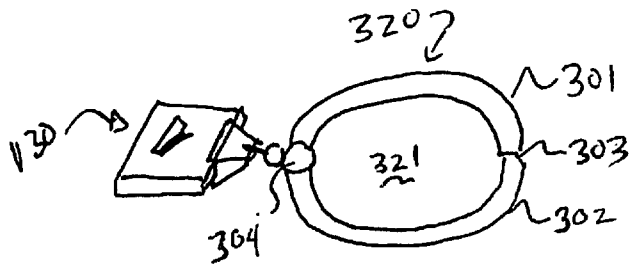

FIG. 6A

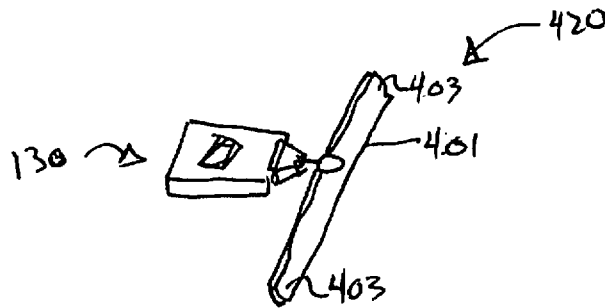

FIG. 7

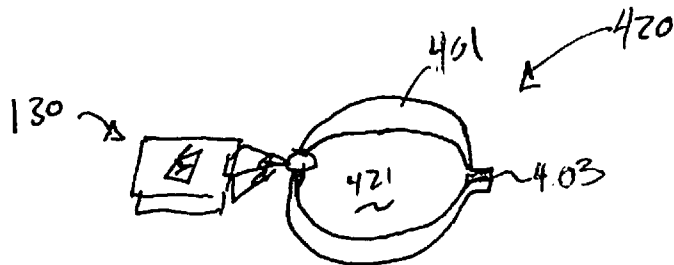

FIG. 7A

FIG. 10A

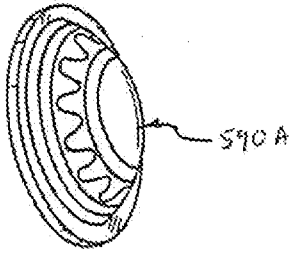

FIG. 10B



FIG. 10C

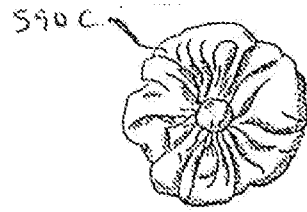
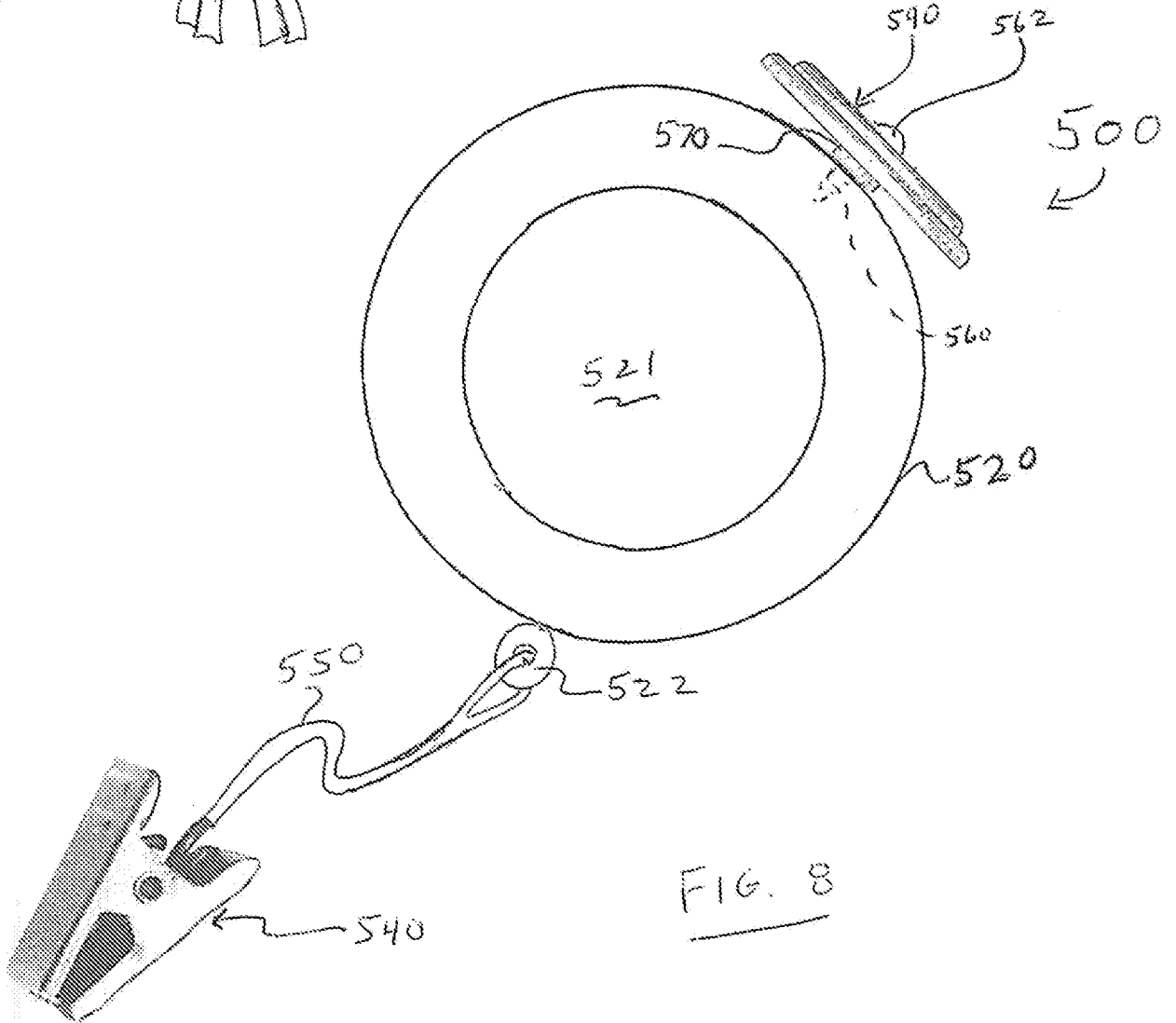
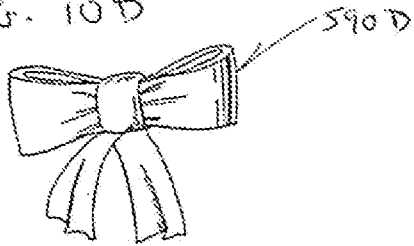

FIG. 10D



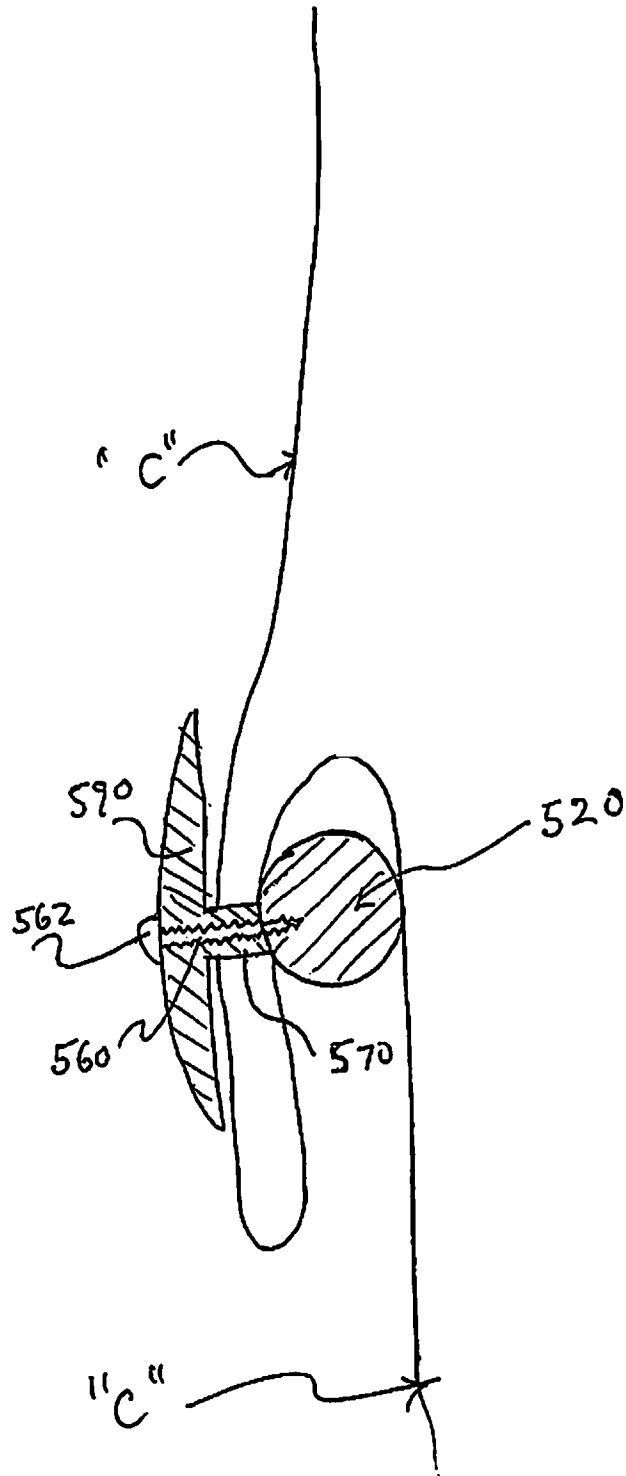

FIG. 9

INTERNATIONAL SEARCH REPORT

International application No.

PCT/US2015/038729

A. CLASSIFICATION OF SUBJECT MATTER

IPC(8) - A47H 19/00 (2015.01)

CPC - A47H 19/00 (2015.09)

According to International Patent Classification (IPC) or to both national classification and IPC

B. FIELDS SEARCHED

Minimum documentation searched (classification system followed by classification symbols)

IPC(8) - A47H 13/00, 13/01, 13/04, 13/14, 19/00 (2015.01)

CPC - A47H 13/04, 19/00, 2023/003, 2201/02 (2015.09) (keyword delimited)

Documentation searched other than minimum documentation to the extent that such documents are included in the fields searched

USPC - 24/457, 543, 716; 160/348, 349.1, 349.2

Electronic data base consulted during the international search (name of data base and, where practicable, search terms used)

PatBase, Google Patents, Google, YouTube.

Search terms used: window, curtain, draperies, ring, clip, tether, tassel, tie backs, retractor.

C. DOCUMENTS CONSIDERED TO BE RELEVANT

Category*	Citation of document, with indication, where appropriate, of the relevant passages	Relevant to claim No.
X	US 2006/0117616 A1 (JONES et al) 08 June 2006 (08.06.2006) entire document	1-4
Y		5, 11
Y	US 6,813,976 B2 (MALVINI et al) 09 November 2004 (09.11.2004) entire document	5
Y	DE 8353 C (GUSTAV et al) 24 December 1879 (24.12.1879) see machine translation	1, 6-13
Y	JP 2005-323649 A (YABUNO) 24 November 2005 (24.11.2005) see machine translation	1, 6-13
Y	US 5,305,814 A (FORD et al) 26 April 1994 (26.04.1994) entire document	10-13
A	EP 1 285 614 A1 (KARST et al) 26 February 2003 (26.02.2003) see machine translation	1-13
A	WO 2005/110172 A1 (ROBERTS) 24 November 2005 (24.11.2005) entire document	1-13
A	JP 2007-007348 A (AOYAMA) 18 January 2007 (18.01.2007) see machine translation	1-13

 Further documents are listed in the continuation of Box C. See patent family annex.

* Special categories of cited documents:

"A" document defining the general state of the art which is not considered to be of particular relevance

"E" earlier application or patent but published on or after the international filing date

"L" document which may throw doubts on priority claim(s) or which is cited to establish the publication date of another citation or other special reason (as specified)

"O" document referring to an oral disclosure, use, exhibition or other means

"P" document published prior to the international filing date but later than the priority date claimed

"T" later document published after the international filing date or priority date and not in conflict with the application but cited to understand the principle or theory underlying the invention

"X" document of particular relevance; the claimed invention cannot be considered novel or cannot be considered to involve an inventive step when the document is taken alone

"Y" document of particular relevance; the claimed invention cannot be considered to involve an inventive step when the document is combined with one or more other such documents, such combination being obvious to a person skilled in the art

"&" document member of the same patent family

Date of the actual completion of the international search

01 September 2015

Date of mailing of the international search report

21 SEP 2015

Name and mailing address of the ISA/

Mail Stop PCT, Attn: ISA/US, Commissioner for Patents

P.O. Box 1450, Alexandria, Virginia 22313-1450

Facsimile No. 571-273-8300

Authorized officer

Blaine Copenheaver

PCT Helpdesk: 571-272-4300
PCT OSP: 571-272-7774