

Feb. 6, 1940.

E. SCHULTZE

2,189,228

APPARATUS FOR HOLDING GARMENTS WHILE BEING STRETCHED

Filed Feb. 23, 1937

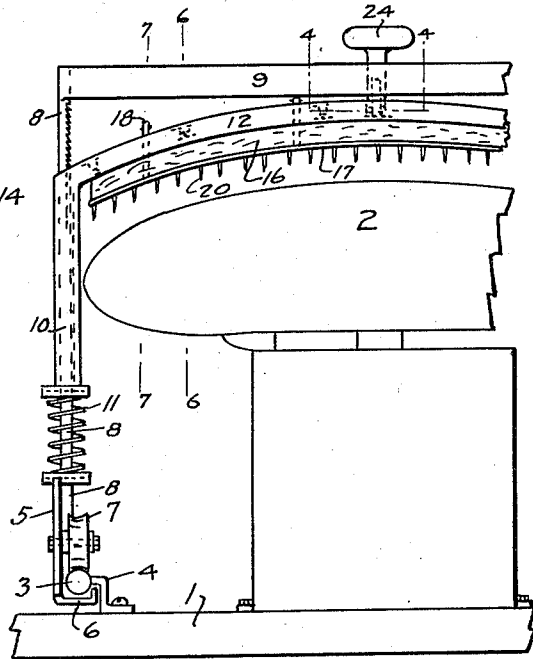
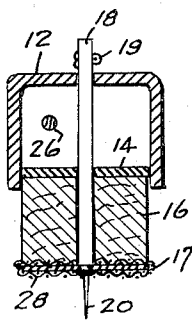
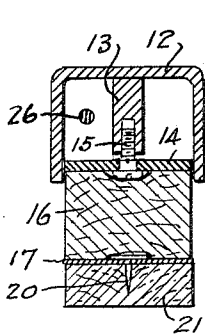
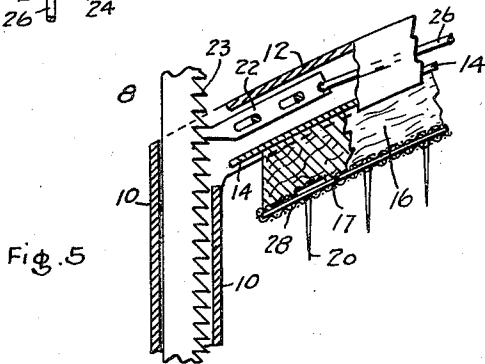
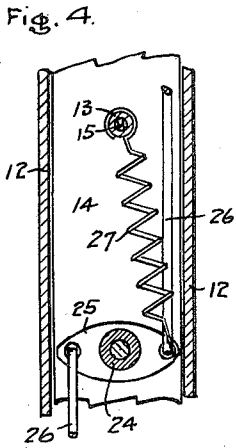
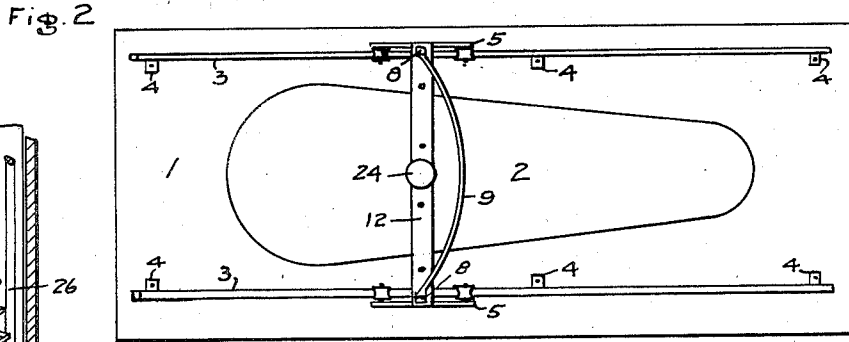
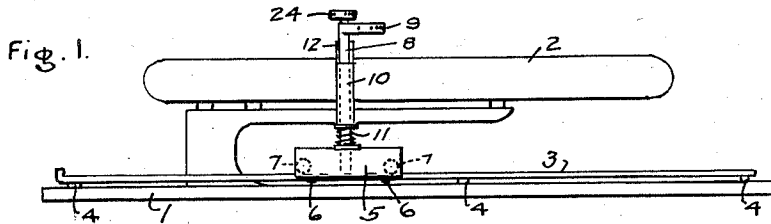

Fig. 3 Inventor

Elmer Schultze

[Handwritten Signature]
 Attorney

334

UNITED STATES PATENT OFFICE

2,189,228

APPARATUS FOR HOLDING GARMENTS WHILE BEING STRETCHED

Elmer Schultze, Tacoma, Wash.

Application February 23, 1937, Serial No. 126,986

3 Claims. (Cl. 38—12)

My invention relates to apparatus for use in cleaning and pressing establishments, and has special reference to an attachment to be mounted on the table of a steam pressing machine whereby one end of a garment may be secured thereto while steam is passed therethrough and while it is being stretched either lengthwise or crosswise of the garment.

The objects of this invention are to provide an apparatus which, when not in use, is slid to one end of the press and which does not interfere with the operation of the press in any manner; which may be quickly slid into place when needed; which can be used at any point of the press; which clamps automatically on the garment; which is resilient and conforms automatically to the shape of the press at that point; which can be used as well on silk goods as woolen or other fabric, without in any way damaging the goods; which can be instantaneously released and retracted from its operating to its inoperative position; and which is cheap and simple to make and to operate and very effective in use.

I attain these and other objects by the devices, mechanisms and arrangements illustrated in the accompanying drawing, in which—

Fig. 1 is a side view of the lower element or buck of a pressing machine, showing my apparatus in position for use thereon; Fig. 2 is a plan view thereof; Fig. 3 is a partial end view thereof drawn to a larger scale; Fig. 4 is a horizontal section of the central part of the arch taken on the line 4—4 in Fig. 3 and illustrating the means for releasing the ratchets; Fig. 5 is a vertical section of a portion thereof to illustrate one of the ratchets; Fig. 6 is a cross-section on the line 6—6 in Fig. 3 and showing the pad for use when silk goods are to be held in place; and Fig. 7 is a similar view on the line 7—7 in Fig. 3 showing the device arranged for woolen goods.

Similar numerals of reference refer to similar parts throughout the several views.

Speed and convenience of operation are the most important requirements of such an apparatus. In order to construct an apparatus which will fulfill these requirements it is necessary that it be mounted so as to be instantly available and capable of being swiftly moved to the desired location, and that it shall be, when so moved, in position for operation without adjustment; and that, when the stretching has been accomplished, it may be released and retracted without the necessity of having to unfasten buckles or straps.

My apparatus fulfills these conditions by being

mounted on guide rails and thus being at all times in operable position, and being movable to any point over the buck; and by the ratchet-clamp means between the vertically movable clamp arch and the supporting carriage, which permits the clamping to be performed by simply pressing down on the arch; and by the releasing knob which may be turned to release both the ratchets and thus permit the carriage to be retracted to the ends of the rails, completely out of the way of any further operation of the steam pressing machine. Each of these actions are exceedingly simple and can be performed with the utmost celerity so that no time is wasted in adjustment or in the removal of the apparatus.

Referring now to the drawing it will be seen that the table 1 supports the lower element or buck 2 of the steam pressing machine in the usual manner. I mount two parallel guide rails 3 on the table 1. These guide rails 3 are preferably circular in cross-section and are supported slightly above the table 1 by suitable supporting lugs 4 which are secured to the inner sides of the said rails 3.

The carriage which rides on the rails and which supports the clamping mechanism, comprises a pair of flat plates 5, having lugs 6 extending from their lower edges, said lugs 6 being bent under the said rails 3 and being adapted to engage the under sides of the said rails, respectively, when a clamping force is being used, thus holding the apparatus down in clamping position. A pair of wheels 7 are mounted at the ends of the said plates 5, on the inner sides thereof, said wheels riding on the rails 3. A pair of vertical bars 8 are mounted at the centers of the two carriage plates 5 and extend upward above the level of the buck 2, and these bars 8 are joined together across the top of the apparatus by a horizontally curved tie bar 9 (Fig. 2). The inner surfaces of these bars 8 are serrated to form a part of the ratchet mechanism (Fig. 5).

Each bar 8 is provided with a sleeve 10 which is freely movable thereon, each said sleeve 10 being impelled upward by the action of the springs 11 mounted between the upper edges of the respective carriage plates 5 and the lower ends of the corresponding sleeves 10 (Fig. 3). The upper ends of these two sleeves 10 are joined together by the arch 12. This arch conforms substantially with the curvature of the upper surface of the buck 2. The arch 12 is made of an inverted channel shape (Figs. 6 and 7), which is provided at intervals with downward-extend-

ing lugs 13 (Fig. 6). A metal arch plate 14 lies between the legs of the inverted channel 12 and is adjustably secured to the said several lugs 13 by means of screws 15, thus permitting a slight adjustment of the curvature of the said arch plate 14. A felt pad 16 is mounted on the under side of the said plate 14. A thin metal plate 17 is mounted below the said felt pad 16 and is secured in place by the loose pins 18 which extend through the pad 16, the arch plate 14 and the arch 12, and are provided with cotter pins 19, or other holding means, above the said arch 12. This thin plate 17 is provided with a plurality of sharp points 20, extending downward therefrom at suitable intervals and which are adapted for use with woolen goods, to pierce the goods and engage the pad of the buck 2. When the apparatus is to be used with silk goods a supplementary strip of felt 21 (Fig. 6) is mounted on the pins 20 to protect the goods from the pins.

The sleeves 10 are held down in clamping position by means of two sliding ratchet dogs 22 suitably mounted in the ends of the arch 12 (Fig. 5) and which extend into engagement with the suitable teeth 23 formed on the inner surfaces of the two vertical bars 8 of the carriage.

The arch 12 carries a central operating knob 24, rotatably mounted thereon, said knob 24 having a double lever or arm 25 secured thereto within the said arch 12. A pair of light rods 26 connect the said arms 25 with the respective ratchet dogs 22. A spring 27, engaging one of the arms 25, forces the dogs 22 outward into engagement with the ratchet teeth 23.

Thus, to apply clamping pressure to the goods, it is only necessary to push down on the knob 24, forcing the arch 12 and all its appliances, downward against the action of the springs 11, thus firmly clamping the goods to the buck 2; but, when it is desired to release the goods therefrom, it is only necessary to turn the knob 24, thus retracting the dogs 22 from the teeth 23, and releasing the arch 12 and its appliances from the goods; and the carriage is then free to be rolled back out of the way of further use of the steam pressing machine.

The above-described felt strip 21 is thick enough to completely envelop the pin points 20, which form a stiffener for the said strip 21 and greatly increase its gripping action on the silk goods, preventing the felt from curling away under the strain from the stretching action ap-

plied to the silk. Since the points do not completely penetrate the strip 21, they do not engage the silk and therefore the stretching force does not cause the silk to be unevenly stretched, as would be the case if it were held at separated points by means of the pin points 20.

The thin plate 17, above described, is preferably sheathed in cloth 28 (Fig. 7) to prevent moisture from condensing on the metal and thus causing the metal to stain the goods. This cloth 28 also increases the friction between the parts so that the major portion of the stress created by stretching the goods is carried by the clamping action of the arch, the points 20 simply reinforcing this clamping action.

It is, of course, understood that the invention illustrated and described herein is in the preferred form but that many variations may be made in the details thereof without departing from the spirit of my invention as outlined in the appended claims. The words and terms in the description and claims are chosen for convenience but are intended to be as generic in their meaning as the art will permit.

Having, therefore, described my invention, what I claim and desire to secure by Letters Patent, is—

1. In garment-holding apparatus, the combination with the table and buck of a pressing machine, of a pair of parallel rails secured to said table one on each side of said buck; a carriage mounted on said rails and adapted to move to any position thereon; a vertically movable clamp arch extending above and across said buck and mounted on said carriage, and adapted to clamp goods between it and the buck; and means mounted on said clamp arch and engaging said carriage and adapted to releasably hold said clamp arch in clamping position.

2. A garment-holding apparatus as set forth in claim 1, together with resilient means mounted under said clamp arch and forming a part of the clamp.

3. In a garment-holding apparatus including a buck on which the garment is spread, a clamp arch vertically movable over said buck, and releasable means to lock said clamp arch in clamping position; the combination of a clamp plate adjustably supported by screw means by said clamp arch; and a resilient pad supported under said clamp plate.

ELMER SCHULTZE.