

- 1
- 2 1
- 3 1
- 4
- 5 11

(DRAM)

가 가 가 가

가 가

가 (backlight assembly),

1mm

(210) L (210)가 (100) (110) ,
 (210) (400) 가 . (100) (110) ,

(210) (100) (110) (400) (210) (200) (21
 0) (100) (300), (400) (500)

0) (500) 3 가 , 3 (500) (400) (51
 2

1 3 (100) (300), (200), (40
 0), (500) (100) (100)
 가 (700)

2 (700) 1 L (740) , (400) 가
 가 (720)가 (710) , (730)가
 (800) 가

(700) (400) 가 , (700)
 가 (700) (700) 가 , (700)
 (700) (700) , (700)

, (700) , 3 , (800)
 (500) G

(700) (100) , (700)
 10) (710) (100) (130)가 (7
 (130)가

, (230) (230) (700)
 (760)가 (230) (400)

(700) (710) (100) (130)
 (800) 가 (730) (700)

, (800) TFT TFT 가 TFT 가
 3 , TFT TFT 가 -
 가 TFT 가 TFT (810), TFT (810) TFT (820), TFT (810) TFT (820)

	TFT	가	TFT	가	()
	(700)	(800)가	(700) 가	(730)	()
		(800)		(850)가	-
4	4	가			
4	(200)가	(100)	(300)	, 1	(210)가
L		(300)		(310)가	
		(230)		(250, 310)	
			(100)		
5	5	11	4		
5		(100)	(100)	(300)	, 6
		(100)	가	(310)가	(300)
0	, 7	(400)	(310)	(310)	(300)
				가	(40)
	(300)	(400)	, 8	(400)	(500)
		3	(500)	, 3	(500)
		(510)			(400)
9		(400)	(100)		, 4
	(200)가	-			
1		(100)	(210)가	(110)	
	(210)가 L				
	(200)가	, 10	(400) 가	(100)	
		(700)		(700)	(710)
	(100)	(130)			
	(700) 가	(720)	(400)	가	
	(200)	(210)			
	, 11	(700)	가	(730)	
	(800)	(850)	(800)	(100)	

(57)

1.

;

;

;

;

가 가

가 가

2.

1

가 , 1

;

;

;

3.

1

가 , 1 ;

가 ;

가

4.

3 , ,

5.

3 , 가

6.

2 , ,

7.

2 , 가 ,

8.

1 ,

9.

, , 가 가 가 ;

가 가

10.

;

;

1

;

;

가

,

가

11.

10

,

.

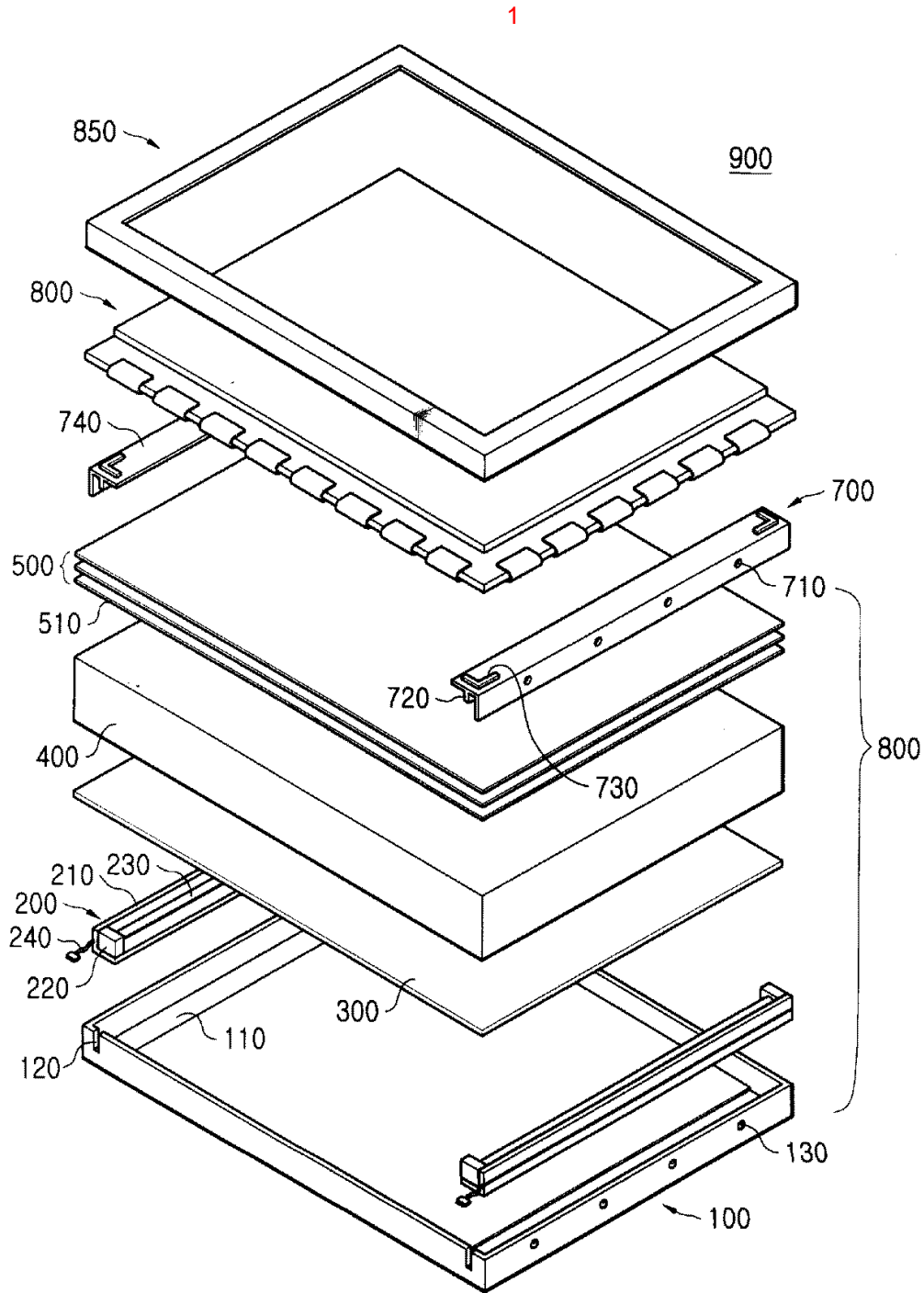

2

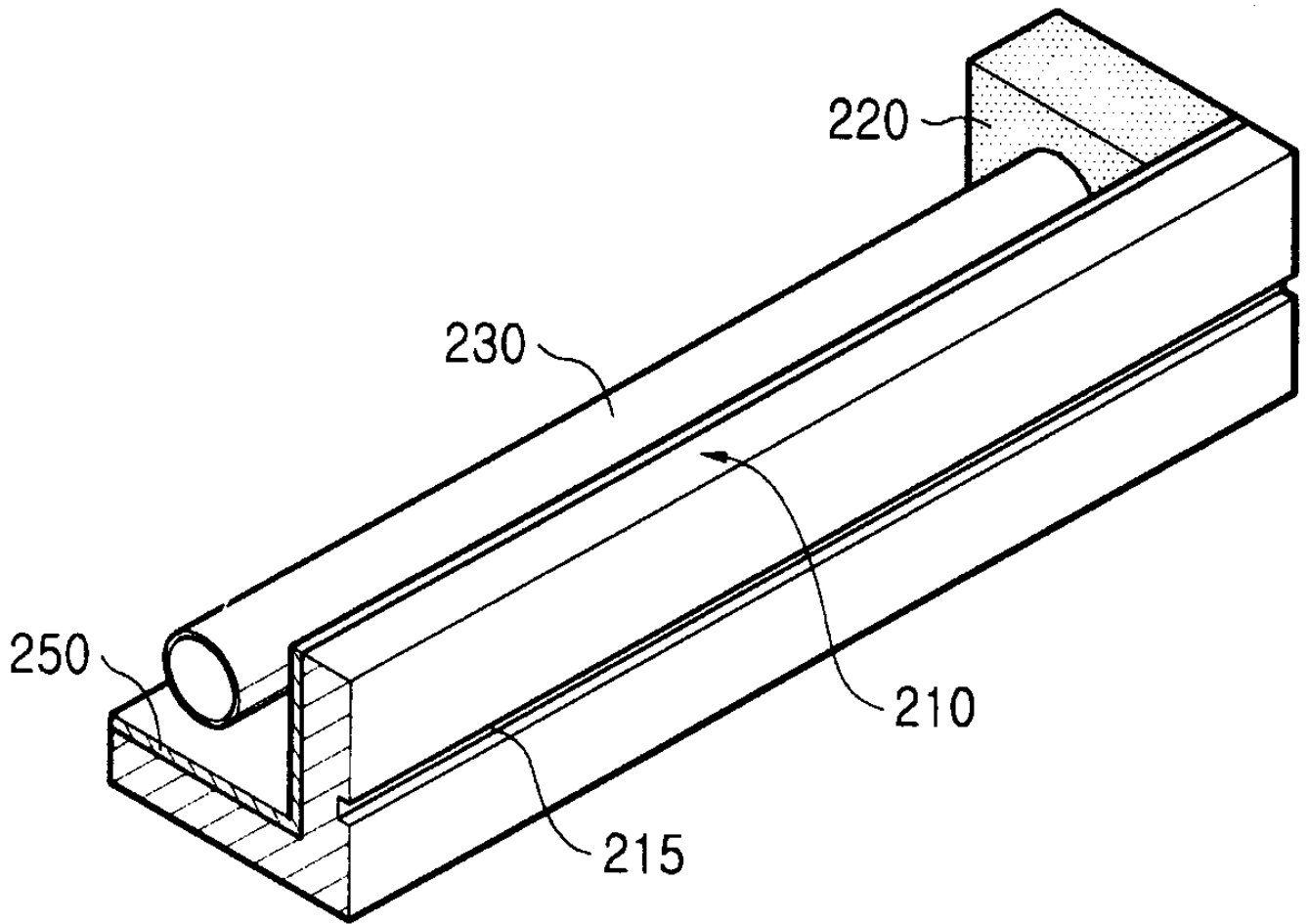

3

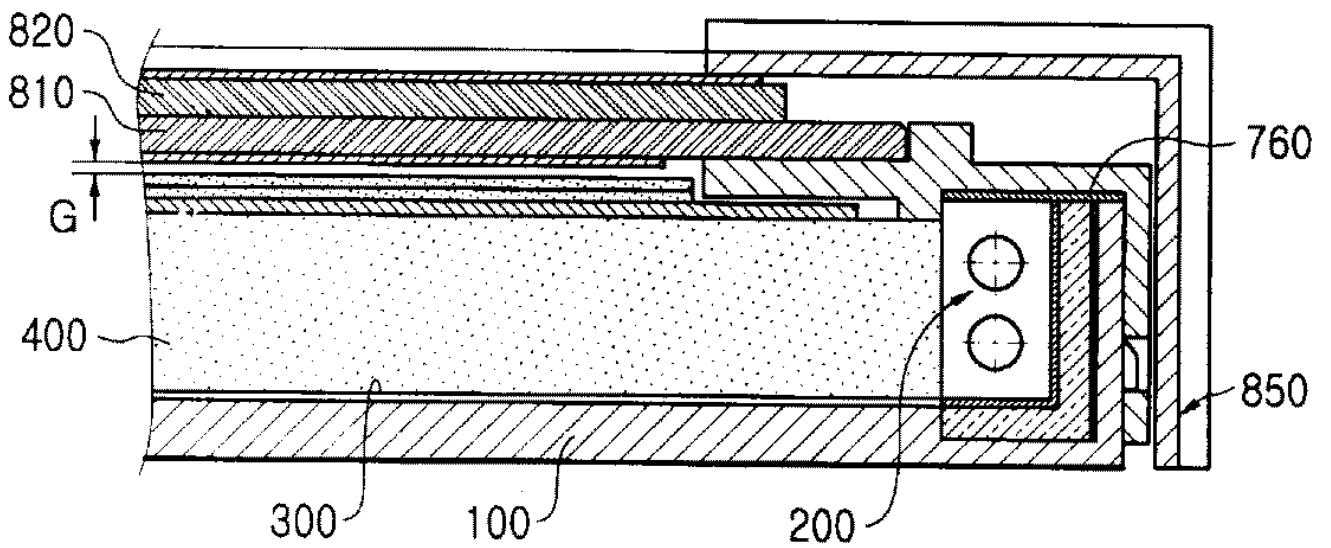

4

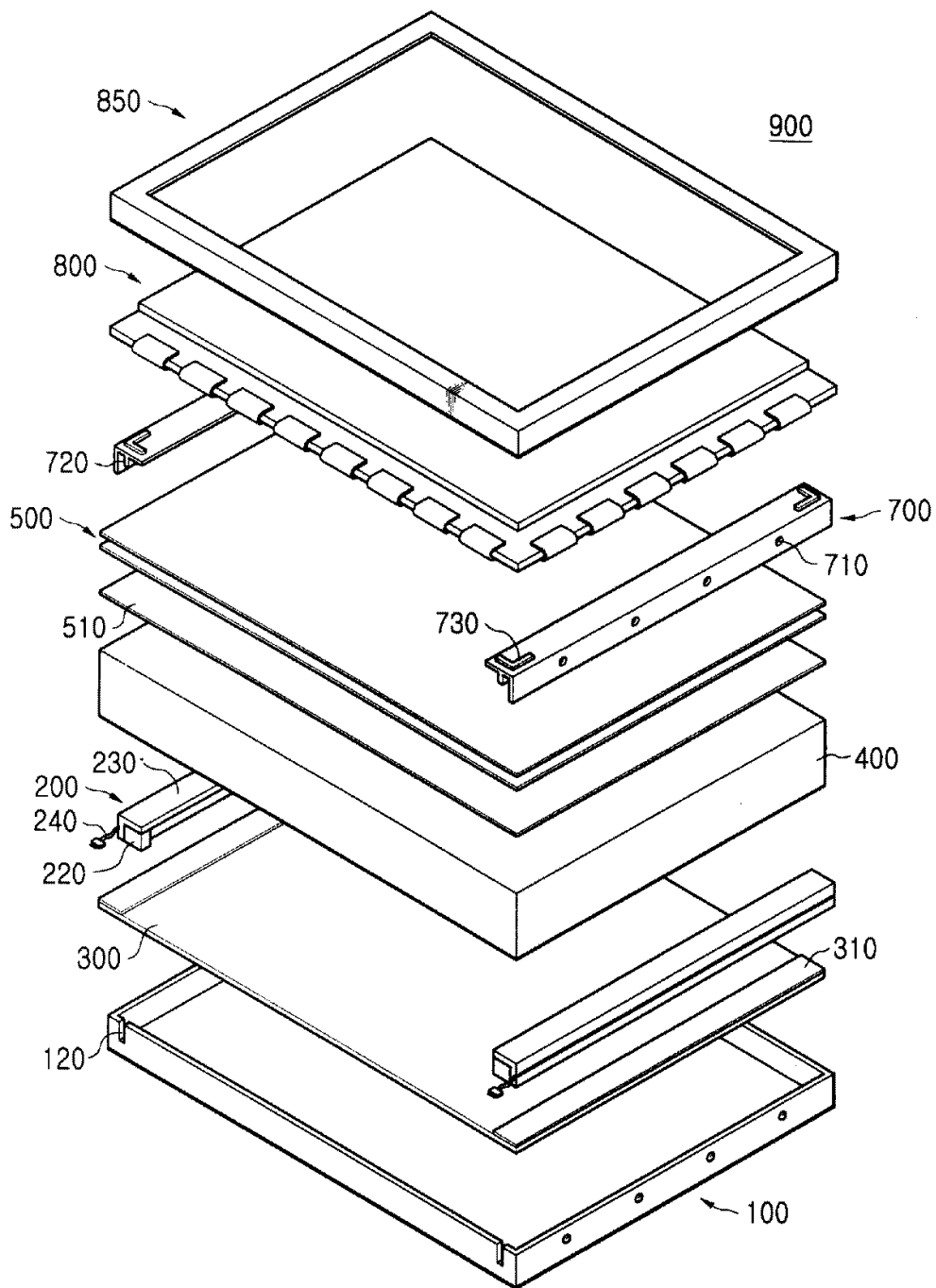

5

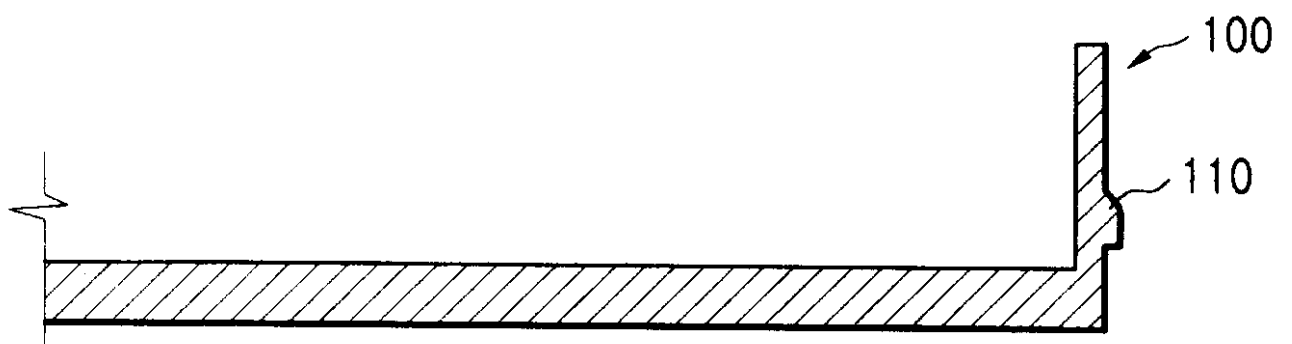

6

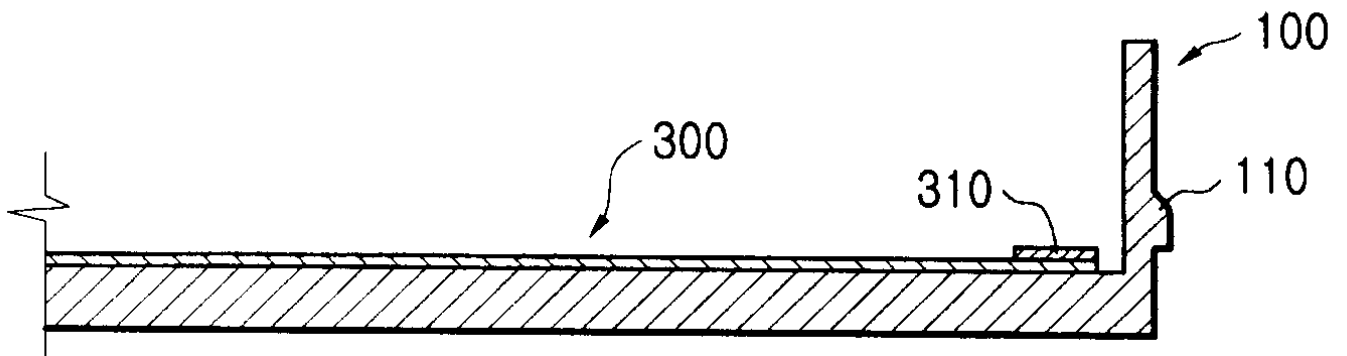

7

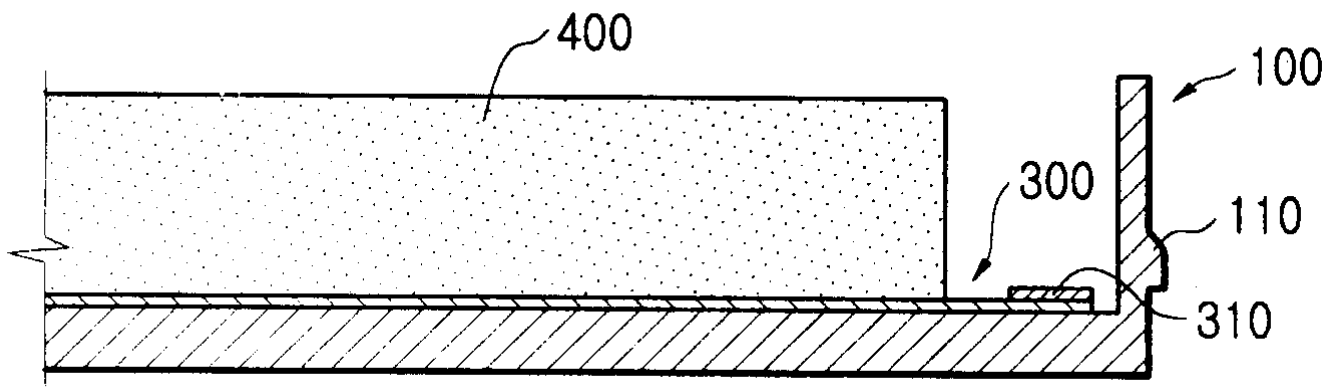

8

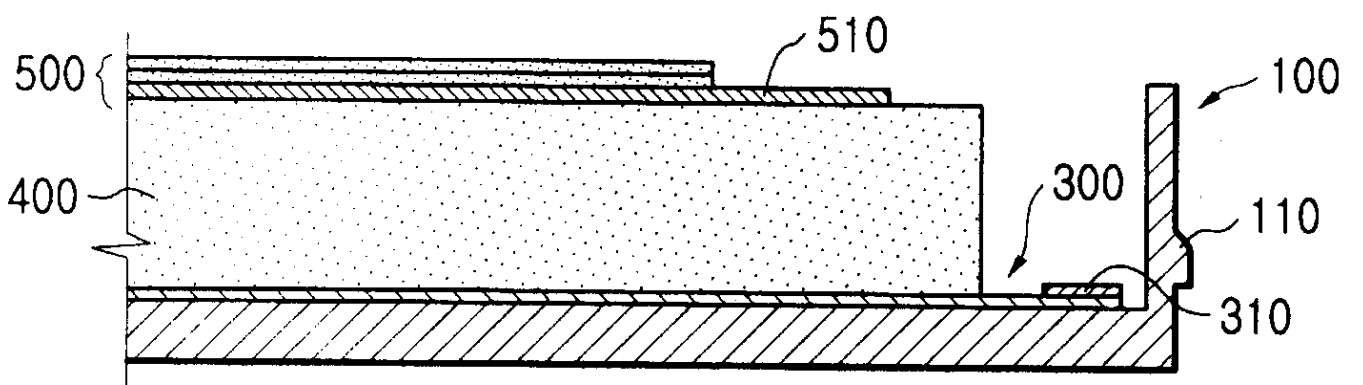

9

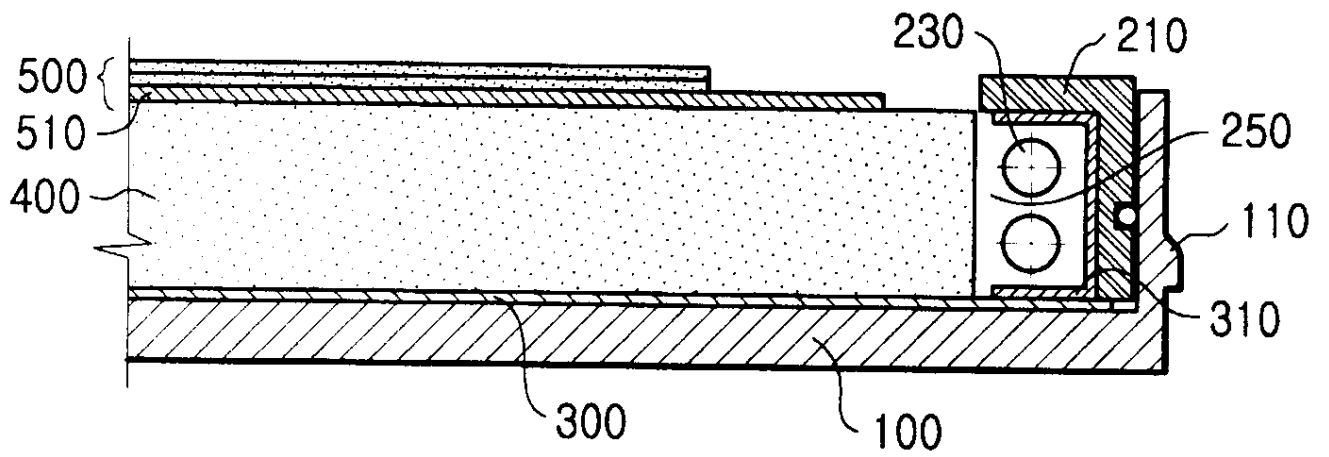

10

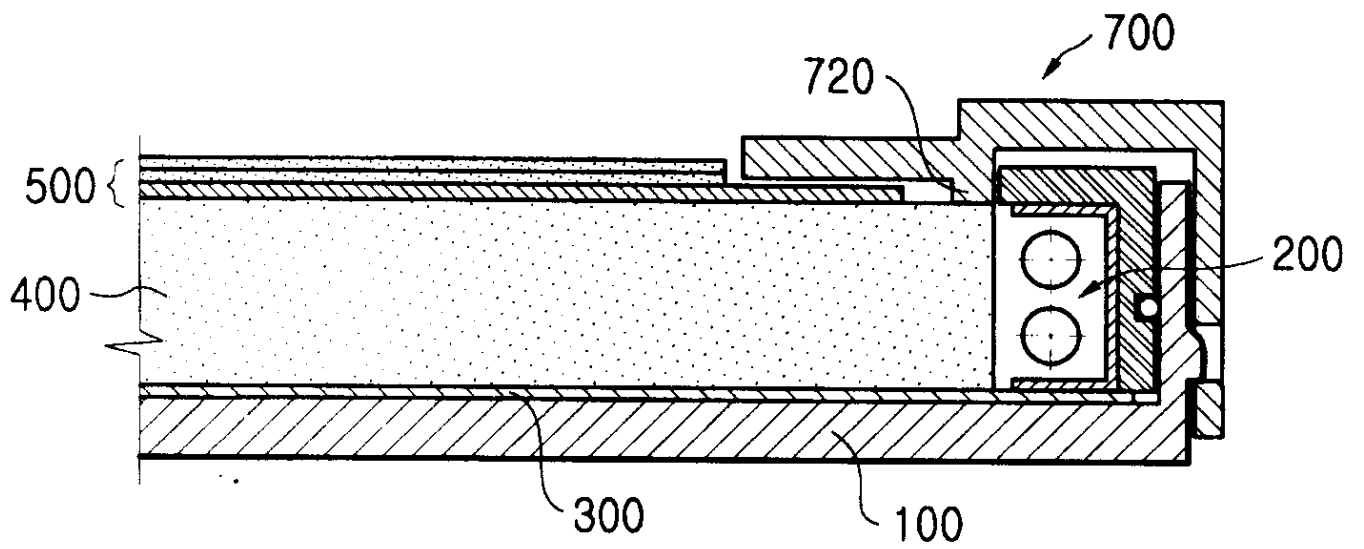

11

