

(No Model.)

3 Sheets—Sheet 1.

S. C. NORTH.
AUTOMATIC INJECTOR BURNER.

No. 494,591.

Patented Apr. 4, 1893.

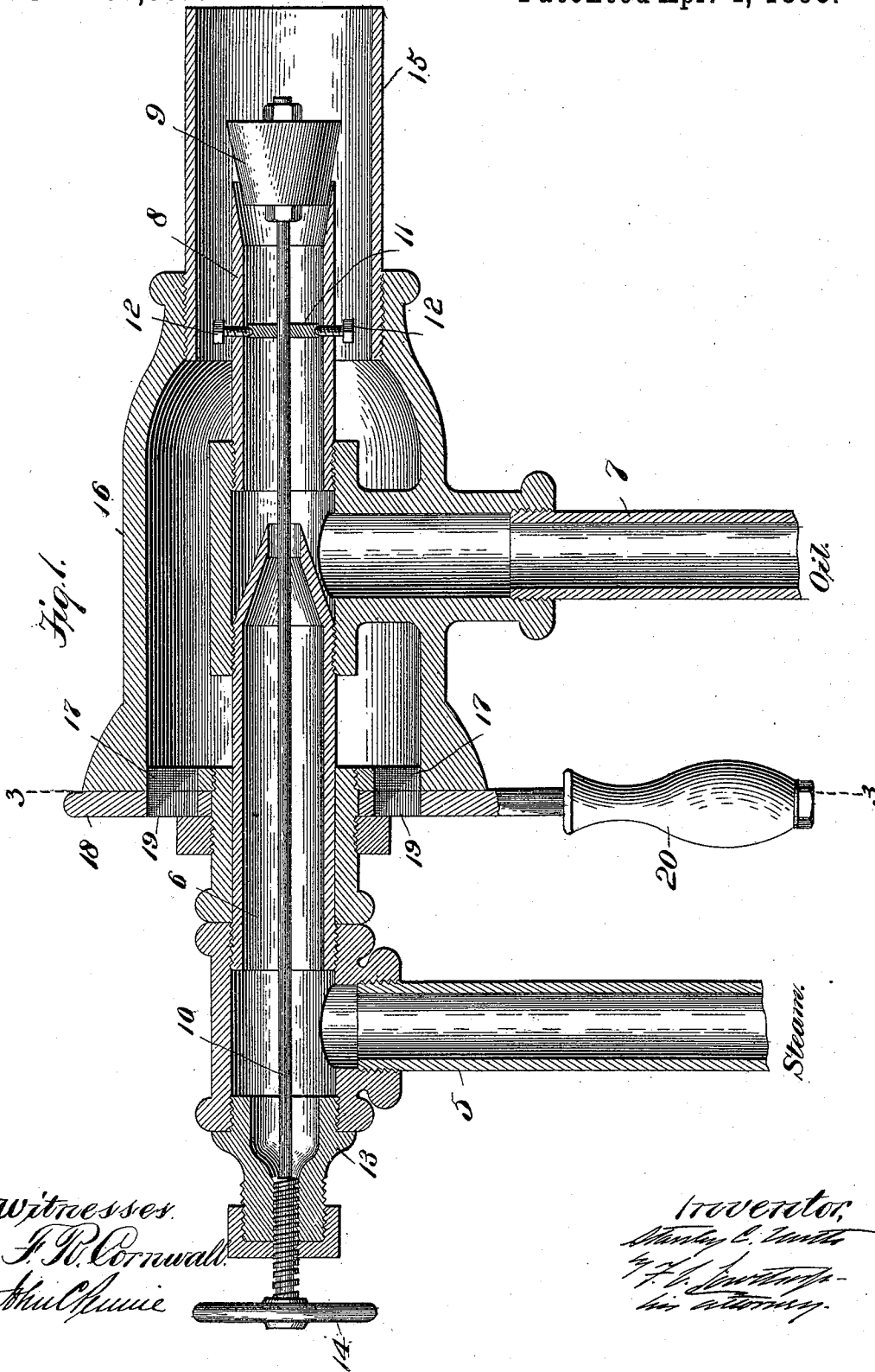

Fig. 1.

Witnesses:
J. R. Cornwall
Michael Muir

Inventor,
Samuel C. North
by
W. H. [unclear]
his attorney.

(No Model.)

3 Sheets—Sheet 2.

S. C. NORTH. AUTOMATIC INJECTOR BURNER.

No. 494,591.

Patented Apr. 4, 1893.

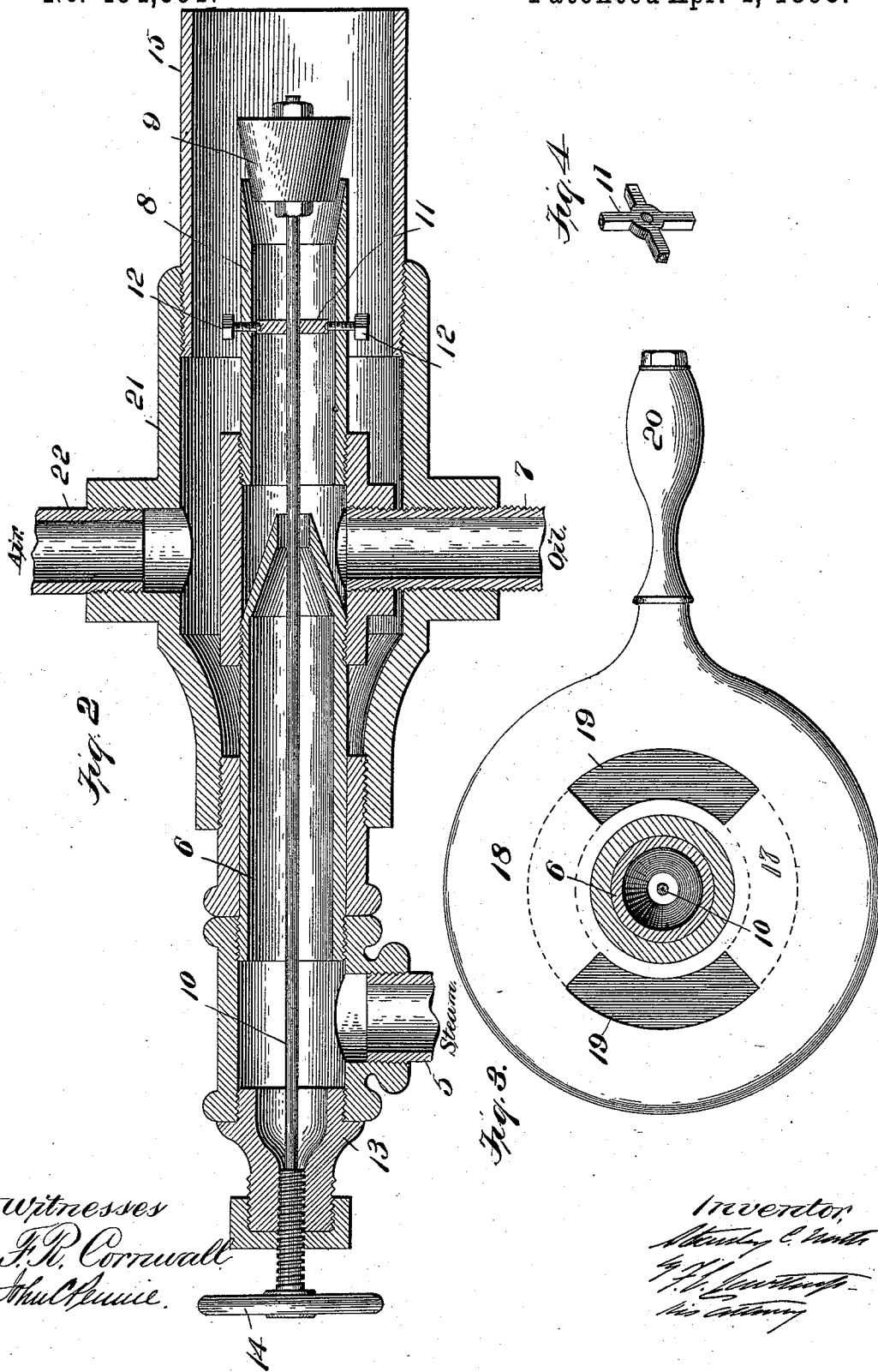

Witnesses
J. P. Cornwall
Shulman

Inventor,
S. C. North
J. H. [unclear]
his attorney

(No Model.)

3 Sheets—Sheet 3.

S. C. NORTH.
AUTOMATIC INJECTOR BURNER.

No. 494,591.

Patented Apr. 4, 1893.

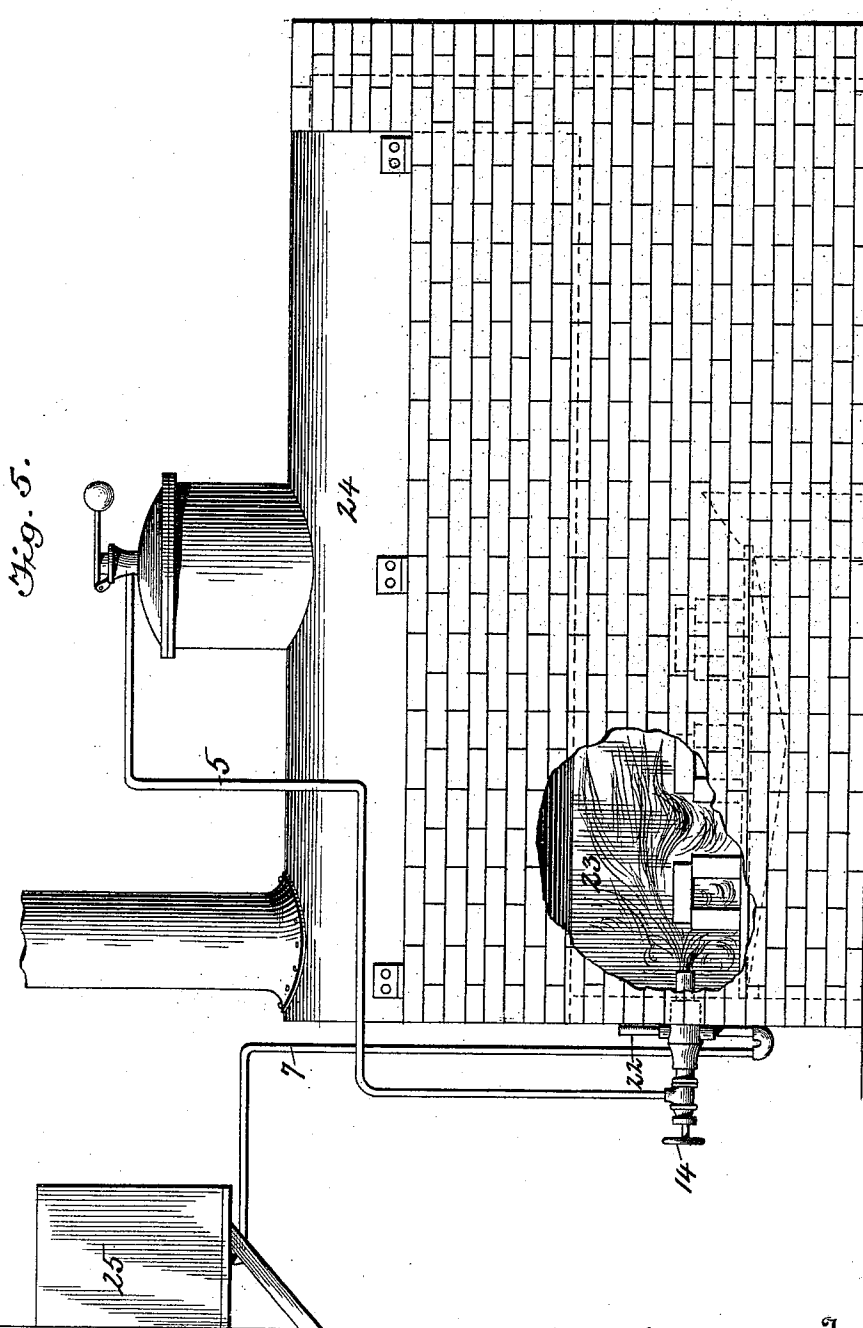

Fig. 5.

Witnesses
John D. Quinn
Lucy B. Hills

Inventor
Stanley C. North
By Quinn & Goldsborough
Attorneys

UNITED STATES PATENT OFFICE.

STANLEY C. NORTH, OF TARRYTOWN, NEW YORK.

AUTOMATIC INJECTOR-BURNER.

SPECIFICATION forming part of Letters Patent No. 494,591, dated April 4, 1893.

Application filed February 11, 1892. Serial No. 421,149. (No model.)

To all whom it may concern:

Be it known that I, STANLEY C. NORTH, a citizen of the United States, residing at Tarrytown, in the county of Westchester and State of New York, have invented certain new and useful Improvements in Automatic Injector-Burners; and I do hereby declare the following to be a full, clear, and exact description of the invention, such as will enable others skilled in the art to which it appertains to make and use the same.

The object of my invention is to provide an injector burner wherein the supply of oil through the flame outlet is automatically varied inversely to the pressure of the steam injecting it; so that should said pressure either fall below or exceed the normal limit at which the apparatus is set, the amount of oil injected will be correspondingly increased or diminished. A steam boiler furnace supplied with a burner or burners of this character will therefore automatically vary their calorific effect to maintain constantly a predetermined pressure of steam within the steam generator; thereby avoiding waste of fuel, while, at the same time, causing the burners to respond automatically, without manual intervention, to the varying demands put upon them.

In the accompanying drawings, Figure 1 represents a longitudinal central section of one form or modification of my invention. Fig. 2 represents a like view of a second form or modification thereof. Fig. 3 represents a cross section and elevation on the line 3—3 of Fig. 1. Fig. 4 represents, in perspective, a detail of construction. Fig. 5 represents a side elevation of a steam boiler furnace fitted with my improved burner, a portion of the furnace wall being shown as broken away.

Similar numerals of reference indicate similar parts throughout the several views.

Referring to the drawings it will be noted that the apparatus is provided with a steam supply pipe 5 communicating with a jet nozzle 6, whose discharge orifice is in close proximity to an oil supply pipe 7. In front of the jet nozzle 6 is located a pipe 8, said pipe being preferably provided with a flaring delivery end whose inner walls correspond in outline to a conical plug 9, fixed upon the end of a spindle 10. The spindle 10 is supported

near its outer end, for instance, by the spider 11, held in place by set screws 12 so that the plug may be accurately centered within the flaring end of the pipe 8; at its inner end the spindle is externally screw-threaded, as shown, where it passes through the bushing 13 and is provided with an operating hand-wheel 14, whereby the plug 9 may be set so as to establish an annular space of the dimensions appropriate to the particular requirements of the case in hand.

Surrounding the pipe 8 and extending beyond it is an outer pipe 15, for the supply of air to the issuing oil and steam. In the form of my invention shown in Figs. 1 and 3, this pipe forms the continuation of a chamber 16 having openings 17 adapted to be regulated in area by means of the rotatory register slide 18 having similar openings 19 and provided with an operating handle 20.

In the form of my invention shown in Fig. 2, I have adopted a form of chamber 21, having an air supply pipe 22, whereby, if desired, pre-heated air instead of cold air may be supplied to the burner.

The operation of the invention is as follows: By means of the hand-wheel 14 and its spindle 10, the plug 9 is set at such an adjustment within the flaring end of the pipe 8 as has been found to be appropriate for the generation of steam at the pressure desired. Steam is then admitted through the pipe 5 and in passing the oil pipe 7 it draws oil up through said pipe and together with the oil enters the mixing and regulating pipe 8, and thence passes through the annular space between the plug 9 and the end of the pipe 8. The current of oil and steam is ignited as it issues into the pipe 15, where it meets a current of air aiding combustion. It will be noted that the pipe 15 is extended beyond the pipe 8 and plug 9 to such a distance that the combined jet of steam and oil is directed upon the inner walls of the pipe 15. It results that the current of air drawn in by the steam and oil jet is consequently brought into the most intimate contact with the particles of said jet, thereby insuring an efficient combustion. The admission of air may be regulated by adjusting the register slide 18, or by means of a cock in the pipe 22, as the case may be. If

now, the steam supplied through the pipe 5 increases in pressure beyond the normal degree to which the burner is set, the back pressure from the plug 9 will be correspondingly increased, and will cause a diminution in the oil-supply, by reason of the fact that such back pressure interferes with the effective lifting action of the steam jet above the oil supply pipe. Consequently, the supply of oil to the burner is cut down, the heating effect of the burner will be correspondingly diminished and this will continue until the pressure in the boiler supplying the steam is brought back to the normal degree. In like manner, a decrease in the pressure of the steam, causing a diminished back pressure within the pipe 8 will permit the jet pipe 6 to draw up and inject an increased supply of oil, thereby raising the heating effect of the burner until the steam resumes its normal pressure. It will thus be seen that where the burner is employed to generate steam, a portion of the steam being used to supply the pipe 5, the burner operates automatically to maintain the boiler pressure to which the apparatus is set. It is evident that by operating the hand wheel 14 so as to adjust the plug to a different position with respect to the end of the pipe 8, the burner may be set to correspond with and automatically maintain, a different steam pressure within the boiler. In practice, I have found that the burner is extremely sensitive in operation, responding at once to accidental variations of steam pressure and restoring the normal pressure with facility and celerity.

It will, of course, be understood that in starting the burner, steam may be admitted into the supply pipe 5 from any suitable source; but after steam of the desired pressure has been raised in the boiler heated by the burner, then the pipe 5 is to receive its supply from said boiler.

In Fig. 5, I have shown a boiler furnace provided with one of my improved burners, entering the combustion chamber 23, the steam supply being derived from the dome of the boiler 24, and the oil supply from the reservoir 25.

Having thus described my invention, what I claim is—

1. An automatic injector burner, comprising a steam inlet pipe having a jet discharge opening; an oil supply pipe whose inlet is in close proximity to the steam jet; a mixing and regulating pipe into which the steam and oil pipes enter, said mixing and regulating pipe having a contractible outlet; and an air inlet pipe surrounding the mixing and regulating pipe; substantially as described.

2. An automatic injector burner, comprising a steam inlet pipe having a jet discharge opening; an oil supply pipe whose inlet is in close proximity to the steam jet; a mixing and regulating pipe into which the steam and oil pipes enter, said mixing and regulating pipe having a contractible outlet; substantially as described.

3. In an automatic injector burner comprising a steam inlet pipe having a jet discharge opening; an oil supply pipe whose inlet is in close proximity to the steam jet; a mixing and regulating pipe into which the steam and oil pipes enter; a plug located within the discharge opening of the mixing and regulating pipe; and a spindle for causing said plug to advance or recede so as to vary the annular space between it and the pipe end; substantially as described.

4. In an automatic injector burner comprising a steam inlet pipe having a jet discharge opening; an oil supply pipe whose inlet is in close proximity to the steam jet; a mixing and regulating pipe into which the steam and oil pipes enter; a plug located within the discharge opening of the mixing and regulating pipe; and a spindle for causing said plug to advance or recede so as to vary the annular space between it and the pipe end; and an air inlet pipe surrounding the mixing and regulating pipe; substantially as described.

In testimony whereof I affix my signature in presence of two witnesses.

STANLEY C. NORTH.

Witnesses:

J. B. CONKLING,
S. W. VAN SYCKEL.