



(51) International Patent Classification:

H03K 17/96 (2006.01) H03K 17/94 (2006.01)

(21) International Application Number:

PCT/US2018/064662

(22) International Filing Date:

10 December 2018 (10.12.2018)

(25) Filing Language:

English

(26) Publication Language:

English

(30) Priority Data:

62/596,522 08 December 2017 (08.12.2017) US

(71) Applicant: **MOLEX, LLC** [US/US]; 2222 Wellington Court, Lisle, Illinois 60532 (US).

(72) Inventors: **FULTON, Steven**; c/o Molex, LLC, 2222 Wellington Court, Lisle, Illinois 60532 (US). **SHANNON, Matthew**; c/o Molex, LLC, 2222 Wellington Court, Lisle, Illinois 60532 (US).

(74) Agent: **HUANG, Bo**; Molex, LLC, 2222 Wellington Court, Lisle, Illinois 60532 (US).

(81) Designated States (unless otherwise indicated, for every kind of national protection available): AE, AG, AL, AM, AO, AT, AU, AZ, BA, BB, BG, BH, BN, BR, BW, BY, BZ, CA, CH, CL, CN, CO, CR, CU, CZ, DE, DJ, DK, DM, DO, DZ, EC, EE, EG, ES, FI, GB, GD, GE, GH, GM, GT, HN, HR, HU, ID, IL, IN, IR, IS, JO, JP, KE, KG, KH, KN, KP, KR, KW, KZ, LA, LC, LK, LR, LS, LU, LY, MA, MD, ME, MG, MK, MN, MW, MX, MY, MZ, NA, NG, NI, NO, NZ,

OM, PA, PE, PG, PH, PL, PT, QA, RO, RS, RU, RW, SA, SC, SD, SE, SG, SK, SL, SM, ST, SV, SY, TH, TJ, TM, TN, TR, TT, TZ, UA, UG, US, UZ, VC, VN, ZA, ZM, ZW.

(84) Designated States (unless otherwise indicated, for every kind of regional protection available):

ARIPO (BW, GH, GM, KE, LR, LS, MW, MZ, NA, RW, SD, SL, ST, SZ, TZ, UG, ZM, ZW), Eurasian (AM, AZ, BY, KG, KZ, RU, TJ, TM), European (AL, AT, BE, BG, CH, CY, CZ, DE, DK, EE, ES, FI, FR, GB, GR, HR, HU, IE, IS, IT, LT, LU, LV, MC, MK, MT, NL, NO, PL, PT, RO, RS, SE, SI, SK, SM, TR), OAPI (BF, BJ, CF, CG, CI, CM, GA, GN, GQ, GW, KM, ML, MR, NE, SN, TD, TG).

Published:

- with international search report (Art. 21(3))
- before the expiration of the time limit for amending the claims and to be republished in the event of receipt of amendments (Rule 48.2(h))

(54) Title: BACKLIT USER INTERFACE

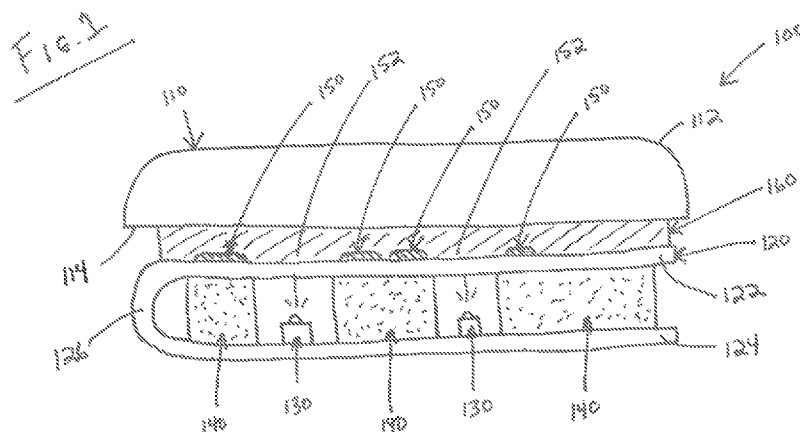

(57) Abstract: An user interface device includes a lens with a top surface and a bottom surface, where the bottom surface includes at least one graphic that is visible through the top surface of the lens. The user interface device further includes a transparent circuit film with a top surface and a bottom surface, at least one light emitting diode (LED), at least one silver conductor, and a layer of transparent pressure-sensitive adhesive that secures the bottom surface of the lens to the top surface of the transparent circuit film.



BACKLIT USER INTERFACE

CROSS-REFERENCE TO RELATED APPLICATIONS

[0001] This application claims the benefit under 35 U.S.C. § 119(e) of the filing date of U.S. Provisional Patent Application No. 62/596,522, for “BACKLIT USER INTERFACE” which was filed on December 8, 2017, and which is incorporated here by reference.

FIELD OF THE INVENTION

[0002] The present disclosure relates to user interfaces for use on various devices, including virtual personal assistants, home appliances and medical devices.

DESCRIPTION OF RELATED ART

[0003] User interfaces for use on various devices are known. These user interfaces typically use capacitive touch sensing technology. Such user interfaces, however, traditionally require higher cost substrates like printed circuit boards (PCBs) or flexible printed circuits (FPC). These PCBs and FPCs then also require the use of molded light pipes and light guides as the PCBs and FPCs do not allow light to transfer from one side thereof to the other side thereof. Furthermore, flexible light guide films provide poor quality of backlighting and PCBs cannot accommodate curved surfaces or be in-molded. As a result, certain individuals would appreciate further improvements to user interfaces.

SUMMARY

[0004] A user interface device includes a lens with a top surface and a bottom surface, where the bottom surface includes at least one graphic that is visible through the top surface of the lens. The user interface device further includes a transparent circuit film with a top surface and a bottom surface, at least one light emitting diode (LED), at least one silver conductor, and a layer of transparent pressure-sensitive adhesive that secures the bottom surface of the lens to the top surface of the transparent circuit film.

[0005] In a first aspect, the transparent circuit film is in a fold-over configuration such that the transparent circuit film has a top layer and a bottom layer that are connected by a connecting

end portion, where the top layer and the bottom layer are separated a desired distance from one another to allow for the at least one LED and at least one spacer to be positioned therebetween

[0006] In a second aspect, user interface device further includes a reflector film.

BRIEF DESCRIPTION OF THE DRAWINGS

[0007] The present disclosure is illustrated by way of example, and not limited, in the accompanying figures, which are not drawn to scale, in which like reference numerals indicate similar elements and in which:

[0008] FIG. 1 illustrates features of a first embodiment of a backlit user interface;

[0009] FIG. 2 illustrates features of a second embodiment of a backlit user interface;

[0010] FIG. 3 illustrates features of a third embodiment of a backlit user interface;

[0011] FIG. 4 illustrates features of a fourth embodiment of a backlit user interface; and

[0012] FIG. 5 illustrates features of a fifth embodiment of a backlit user interface.

DETAILED DESCRIPTION

[0013] FIGS. 1-5 illustrate exemplary embodiments of the present disclosure and it is to be understood that the disclosed embodiments are merely exemplary of the disclosure, which may be embodied in various forms. Therefore, specific details disclosed herein are not to be interpreted as limiting, but merely as a basis for the claims and as a representative basis for teaching one skilled in the art to variously employ the present disclosure. It is further to be understood that the illustrations are not drawn to scale.

[0014] FIG. 1 illustrates a first embodiment of a backlit user interface 100. The backlit user interface 100 includes a lens 110, a transparent circuit film 120, at least one light emitting diode (LED) 130, at least one spacer 140, at least one silver conductor 150, and a layer of transparent pressure-sensitive adhesive 160.

[0015] The lens 110 is preferably formed of plastic material which is generally transparent. The lens 110 has a top surface 112 and a bottom surface 114. The top surface 112 is preferably curved and is intended to be contacted by a user. The bottom surface 114 is preferably flat and

is intended to have at least one graphic (not illustrated) provided thereon such that the graphic is visible by viewing through the top surface 112 of the lens 110. The graphic may be applied to the bottom surface 114 of the lens 110 in any suitable manner, e.g., spray paint, laser etch, screen-print or digital print.

[0016] The transparent circuit film 120 is preferably formed of polyester (PET). The transparent circuit film 120 is preferably provided in a fold-over configuration such that the transparent circuit film 120 is provided with a top layer 122 and a bottom layer 124 that are connected by a connecting end portion 126. The top layer 122 and the bottom layer 124 are separated a desired distance from one another to allow for the at least one LED 130 and the at least one spacer 140 to be positioned therebetween. The transparent circuit film 120 may be electrically connected to another portion of the device on which the backlit user interface 100 is provided, e.g., by a header connector attached to the circuit with low-temp solder, facing down away from the lens, by a tail that is compatible with a ZIF connector or by contact pads provided on the bottom layer 124, possibly with carbon coating, that are intended for pogo-pins.

[0017] The at least one LED 130 is bonded to the bottom layer 124 of the transparent circuit film 120 in a top-fire position, preferably using a low temperature solder material, such that the at least one LED 130 emits light toward and through the top layer 122 of the transparent circuit film 120.

[0018] The at least one spacer 140 is preferably formed of foam. The at least one spacer 140 is preferably bonded in place between the top and bottom layer 122, 124 of the transparent circuit film 120. The at least one spacer 140 is positioned around the at least one LED 130 and, if more than one LED 130 is provided, the at least one spacer 140 is positioned to separate one LED 130 from another LED 130.

[0019] The at least one silver conductor 150 is preferably screen printed on the top layer 122 of the transparent circuit film 120 to provide at least one capacitive touch sensor. The at least one silver conductor 150 is preferably opaque. The number of silver conductors 150 provided will typically match the number of LEDs 130 provided. Each silver conductor 150 is generally formed in a ring-like configuration such that a space 152 is defined within a middle of the ring-like configuration. In this context, ring-like is intended to mean completely closed (e.g., in an O-shape) or partially closed (e.g., in a C-shape or a U-shape). Each silver conductor

150 is positioned generally above (as viewed in FIG. 1) one of the LEDs 130 such that the space 152 defined is in general vertical alignment (as viewed in FIG. 1) with the LED 130.

[0020] The lens 110 and the transparent circuit film 120 are preferably secured to one another by the layer of transparent pressure-sensitive adhesive 160 and positioned between the bottom surface 114 of the lens 110 and either the top layer 122 of the transparent circuit film 120 or the at least one silver conductor 150. Thus, the layer of transparent pressure-sensitive adhesive 160 occupies the space 152 defined by the at least one silver conductor 150.

[0021] In operation, the light emitted by the at least one LED 130 will pass through the transparent circuit film 120, through the layer of transparent pressure-sensitive adhesive 160 (including the portion thereof that occupies space 152), and onto the graphic (as the graphic is also positioned in general vertical alignment (as viewed in FIG. 1) with the space 152), thereby providing backlighting for the user interface 100 which allows the user to easily view the graphic.

[0022] FIG. 2 illustrates a second embodiment of a backlit user interface 200. The backlit user interface 200 includes a lens 210, a transparent circuit film 220, at least one light emitting diode (LED) 230, a reflector film 270, at least one silver conductor 250, and a layer of transparent pressure-sensitive adhesive 260.

[0023] The lens 210 is preferably formed of plastic material which is generally transparent. The lens 210 has a top surface 212 and a bottom surface 214. The top surface 212 is preferably curved and is intended to be contacted by a user. The bottom surface 214 is preferably flat and is intended to have at least one graphic (not illustrated) provided thereon such that the graphic is visible by viewing through the top surface 212 of the lens 210. The graphic may be applied to the bottom surface 214 of the lens 210 in any suitable manner, e.g., spray paint, laser etch, screen-print or digital print.

[0024] The transparent circuit film 220 is preferably formed of polyester (PET). The transparent circuit film 220 is preferably provided in a single layer 221 having a top surface 223 and a bottom surface 225. The transparent circuit film 220 may be electrically connected to another portion of the device on which the backlit user interface 200 is provided, e.g., by a header connector attached to the circuit with low-temp solder, facing down away from the lens, by a tail that is compatible with a ZIF connector or by contact pads provided on the bottom surface 225, possibly with carbon coating, that are intended for pogo-pins.

[0025] The at least one LED 230 is bonded to the bottom surface 225 of the transparent circuit film 220 in a right angle-fire position, preferably using a low temperature solder material, such that the at least one LED 230 emits light generally parallel to the transparent circuit film 220.

[0026] The reflector film 270 is preferably formed of a white reflector material. The reflector film 270 is preferably bonded in place to the bottom surface 225 of the transparent circuit film 220. The reflector film 270 is configured to provide at least one embossed area 272 which defines a pocket 274 between the reflector film 270 and the bottom surface 225 of the transparent circuit film 220. The number of pockets 274 defined corresponds to the number of LEDs 230 provided as each LED 230 is positioned in a corresponding pocket 274.

[0027] The at least one silver conductor 250 is preferably screen printed on the top surface 223 of the transparent circuit film 220 to provide at least one capacitive touch sensor. The at least one silver conductor 150 is preferably opaque. The number of silver conductors 250 provided will typically match the number of LEDs 230 provided. Each silver conductor 250 is generally formed in a ring-like configuration such that a space 252 is defined within a middle of the ring-like configuration. In this context, ring-like is intended to mean completely closed (e.g., in an O-shape) or partially closed (e.g., in a C-shape or a U-shape). Each silver conductor 250 is positioned generally above (as viewed in FIG. 2) one of the pockets 274 such that the space 252 defined is in general offset from being in vertical alignment (as viewed in FIG. 2) with the LED 230.

[0028] The lens 210 and the transparent circuit film 220 are preferably secured to one another by the layer of transparent pressure-sensitive adhesive 260 and positioned between the bottom surface 214 of the lens 210 and either the top surface 223 of the transparent circuit film 220 or the at least one silver conductor 250. Thus, the layer of transparent pressure-sensitive adhesive 260 occupies the space 252 defined by the at least one silver conductor 250.

[0029] In operation, light emitted by the at least one LED 230 will pass through the transparent circuit film 220 (either directly or after bouncing off of the reflector film 270), through the layer of transparent pressure-sensitive adhesive 260 (including the portion thereof that occupies space 252), and onto the graphic (as the graphic is also positioned in general vertical alignment (as viewed in FIG. 2) with the space 252), thereby providing backlighting for the user interface 200 which allows the user to easily view the graphic.

[0030] FIG. 3 illustrates a third embodiment of a backlit user interface 300. The backlit user interface 300 includes a lens 310, a transparent circuit film 320, at least one light emitting diode (LED) 330, a reflector film 370, at least one spacer 340, at least one silver conductor 350, and a layer of transparent pressure-sensitive adhesive 360.

[0031] The lens 310 is preferably formed of plastic material which is generally transparent. The lens 310 has a top surface 312 and a bottom surface 314. The top surface 312 is preferably curved and is intended to be contacted by a user. The bottom surface 314 is preferably flat and is intended to have at least one graphic (not illustrated) provided thereon such that the graphic is visible by viewing through the top surface 312 of the lens 310. The graphic may be applied to the bottom surface 314 of the lens 310 in any suitable manner, e.g., spray paint, laser etch, screen-print or digital print.

[0032] The transparent circuit film 320 is preferably formed of polyester (PET). The transparent circuit film 320 is preferably provided in a single layer 321 having a top surface 323 and a bottom surface 325. The transparent circuit film 320 may be electrically connected to another portion of the device on which the backlit user interface 300 is provided, e.g., by a header connector attached to the circuit with low-temp solder, facing down away from the lens, by a tail that is compatible with a ZIF connector or by contact pads provided on the bottom surface 325, possibly with carbon coating, that are intended for pogo-pins.

[0033] The reflector film 370 is preferably formed of a white reflector material. The reflector film 370 is preferably provided in a single layer 371 having a top surface 373 and a bottom surface 375.

[0034] The at least one LED 330 is bonded to the bottom surface 325 of the transparent circuit film 320 in a right angle-fire position, preferably using a low temperature solder material, such that the at least one LED 330 emits light generally parallel to the transparent circuit film 320.

[0035] The at least one spacer 340 is preferably formed of foam. The at least one spacer 340 is preferably bonded in place between the bottom surface 325 of the transparent circuit film 320 and the top surface 373 of the reflector film 370. The at least one spacer 340 is positioned around the at least one LED 330 and, if more than one LED 330 is provided, the at least one spacer 340 is positioned to separate one LED 330 from another LED 330.

[0036] The at least one silver conductor 350 is preferably screen printed on the top surface 323 of the transparent circuit film 320 to provide at least one capacitive touch sensor. The at least one silver conductor 350 is preferably opaque. The number of silver conductors 350 provided will typically match the number of LEDs 330 provided. Each silver conductor 350 is generally formed in a ring-like configuration such that a space 352 is defined within a middle of the ring-like configuration. In this context, ring-like is intended to mean completely closed (e.g., in an O-shape) or partially closed (e.g., in a C-shape or a U-shape). Each silver conductor 350 is positioned generally above (as viewed in FIG. 3) one of the LEDs 330 such that the space 352 defined is in general vertical alignment (as viewed in FIG. 3) with the LED 330.

[0037] The lens 310 and the transparent circuit film 320 are preferably secured to one another by the layer of transparent pressure-sensitive adhesive 360, which is positioned between the bottom surface 314 of the lens 310 and either the top surface 323 of the transparent circuit film 320 or the at least one silver conductor 350. Thus, the layer of transparent pressure-sensitive occupies the space 352 defined by the at least one silver conductor 350.

[0038] In operation, light emitted by the at least one LED 330 will pass through the transparent circuit film 320 (either directly or after bouncing off of the reflector film 370), through the layer of transparent pressure-sensitive adhesive 360 (including the portion thereof that occupies space 352), and onto the graphic (as the graphic is also positioned in general vertical alignment (as viewed in FIG. 3) with the space 352), thereby providing backlighting for the user interface 300 which allows the user to easily view the graphic.

[0039] FIG. 4 illustrates a fourth embodiment of a backlit user interface 400. The backlit user interface 400 is identical to the first embodiment of the backlit user interface 100 (see FIG. 1), except that backlit user interface 400 also includes a microphone 480 as a part thereof, where the lens 110, the layer of pressure-sensitive adhesive 160 and the top layer 122 of the transparent circuit film 120 have an aperture 482 therethrough for the microphone 480. The microphone 480 is preferably bonded to the top layer 122 of the transparent circuit film 120, on the opposite side of the top layer 122 as compared to the at least one silver conductor 150.

[0040] FIG. 5 illustrates a fifth embodiment of a backlit user interface 500. The backlit user interface 500 is identical to the second embodiment of the backlit user interface 200 (see FIG. 2), except that the backlit user interface 500 also includes a microphone 580 as a part thereof, where the lens 210, the layer of pressure-sensitive adhesive 260 and the transparent circuit film

220 have an aperture 582 therethrough for the microphone 580. The microphone 580 is preferably bonded to the bottom surface 225 of the transparent circuit film 220.

[0041] It will be understood that there are numerous modifications of the illustrated embodiments described above which will be readily apparent to one skilled in the art, including combinations of features disclosed herein that are individually disclosed or claimed herein, explicitly including additional combinations of such features, or alternatively other types of embodiments of the same. Also, there are many possible variations in the materials and configurations, including, but not limited to, as examples: (a) the embodiments could be provided with a graphic film could be used instead of a lens; (b) the embodiments could be provided with or without LEDs; (c) the embodiments could be provided with or without LED drive circuitry; (d) the embodiments could be provided with or without microphones; (e) the embodiments could be provided with or without cap-touch chip and firmware; (f) the embodiments could be provided with backlighting of a user interface with LEDs bonded to a low-cost circuit (which provides lower cost as compared to traditional backlit user interfaces); (g) the embodiments could be provided with a substrate that is flexible polyester (which provides the benefits of being lower cost, flexible and transparent); (h) the embodiments could utilize reflective material behind the LEDs to direct the light to the user (which provides better lighting quality); (i) the embodiments could have graphic overlays on top surfaces to create backlit icons; (j) the embodiments could have combined graphical and electrical circuit on one substrate material (which provides lower costs); (k) the embodiments could have graphic/circuit in-molded into a lens/bezel (which allows for use of a curved surface and better appearance); (l) the embodiments could have capacitive touch for sensing user input; (m) the embodiments could have capacitive sensors with ring geometry, allowing backlighting through the transparent center of the ring (which allows for backlighting for keys and better quality than light guide film); (n) the embodiments could have a transparent center of the touch sensor with either no conductor or a transparent conductor (which provides improved backlighting and improved capacitive sensing through thick materials); (o) the embodiments could have LEDs bonded to the circuit with low-temp solder (which provides that there is no substrate damage during SMT); (p) the embodiments could have microprocessor-based circuitry included on the polyester circuit (which provides lower cost); (q) the embodiments could have silver circuit traces applied to the substrate with screen printing (which provides lower cost); (r) the embodiments could have LEDs located a distance away from the capacitive sensor to improve capacitive sensitivity (which allows touch sensing through thicker materials; (s) the

embodiments could have LEDs which are top-fire, right-angle fire, or reverse-fire (which provides different options for quality lighting); (t) the embodiments could have transparent, conductive ink provided in the opening defined by the silver conductor, such that the silver conductor does not need to surround the opening as much as it needs to if the transparent, conductive ink is not used.

CLAIMS

1. An user interface device, comprising:
 - a lens with a top surface and a bottom surface, wherein the bottom surface comprises at least one graphic that is visible through the top surface of the lens;
 - a transparent circuit film with a top surface and a bottom surface;
 - at least one light emitting diode (LED);
 - at least one silver conductor; and
 - a layer of transparent pressure-sensitive adhesive that secures the bottom surface of the lens to the top surface of the transparent circuit film.
2. The user interface device of claim 1, wherein the top surface of the lens is curved and configured to contact a user.
3. The user interface device of claim 1, wherein the graphic is applied to the bottom surface of the lens by at least one of spray paint, laser etch, screen-print, or digital print.
4. The user interface device of claim 1, wherein the bottom surface of the lens is flat.
5. The user interface device of claim 1, wherein the transparent circuit film is formed of polyester (PET).
6. The user interface device of claim 1, wherein the transparent circuit film is in a fold-over configuration such that the transparent circuit film has a top layer and a bottom layer that are connected by a connecting end portion, wherein the top layer and the bottom layer are separated by a desired distance to allow for the at least one LED and at least one spacer to be positioned therebetween.
7. The user interface device of claim 6, wherein the at least one LED is bonded to the bottom layer of the transparent circuit film in a top-fire position, such that the at least one LED emits light toward and through the top layer of the transparent circuit film.
8. The user interface device of claim 6, wherein the at least one spacer is formed of foam and bonded in place between the top and bottom layer of the transparent circuit film.

9. The user interface of claim 6, further comprising a microphone bonded to the top layer of the transparent circuit film.
10. The user interface of claim 9, wherein the lens, the layer of pressure-sensitive adhesive, and the top layer of the transparent circuit film have an aperture therethrough for the microphone.
11. The user interface device of claim 1, wherein the at least one silver conductor is screen printed on the top surface of the transparent circuit film to provide at least one capacitive touch sensor.
12. The user interface device of claim 1, further comprising a reflector film across from the bottom surface of the transparent circuit film.
13. The user interface of claim 12, wherein the reflector film is bonded to the bottom surface of the transparent circuit film, wherein the reflector film is configured to provide at least one embossed area which defines a pocket between the reflector film and the bottom surface of the transparent circuit film.
14. The user interface device of claim 12, wherein the at least one LED is bonded to the bottom surface of the transparent circuit film in a right angle-fire position.
15. The user interface device of claim 12, further comprising at least one spacer bonded in place between the bottom surface of the transparent circuit film and a top surface of the reflector film, wherein the at least one spacer is positioned around the at least one LED.
16. The user interface of claim 12, further comprising a microphone bonded to the bottom surface of the transparent circuit film.
17. The user interface of claim 16, wherein the lens, the layer of pressure-sensitive adhesive, and the transparent circuit film, have an aperture therethrough for the microphone.

FIG. 1

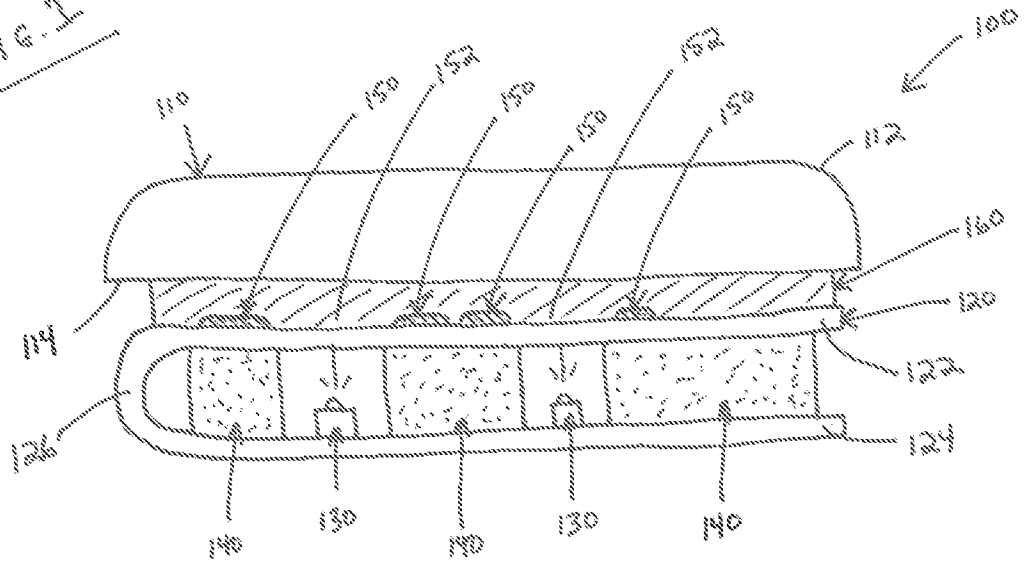

FIG. 2

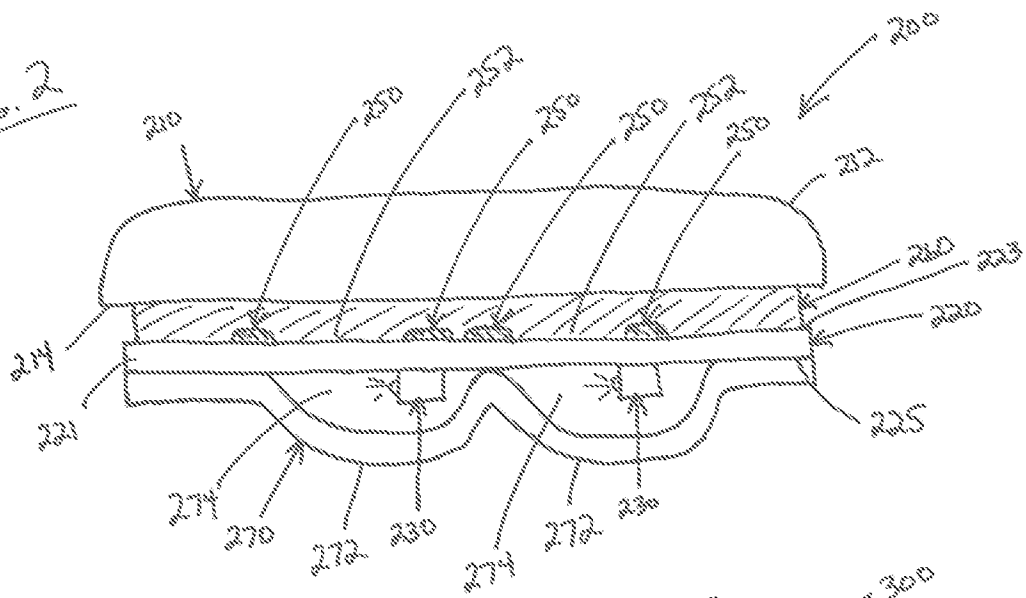

FIG. 3

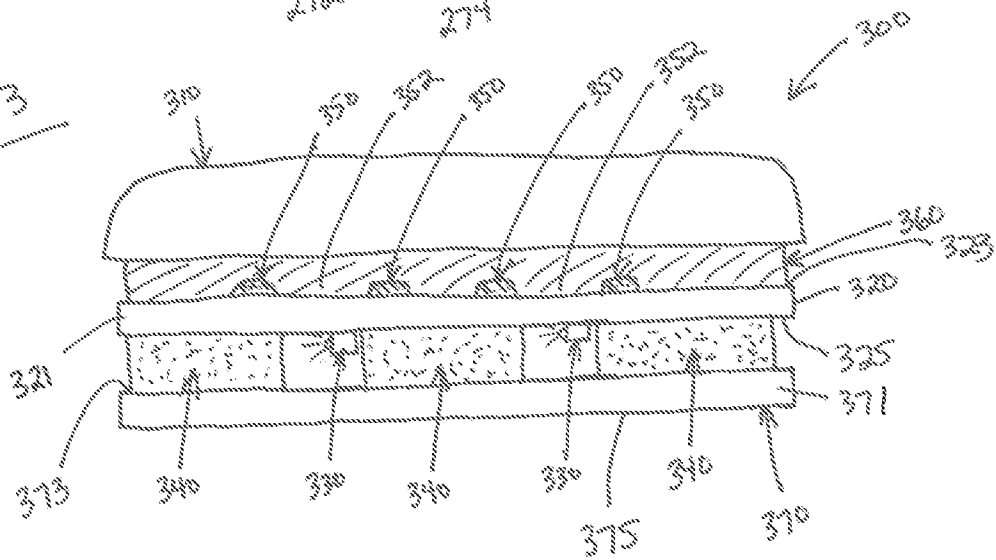

FIG. 4

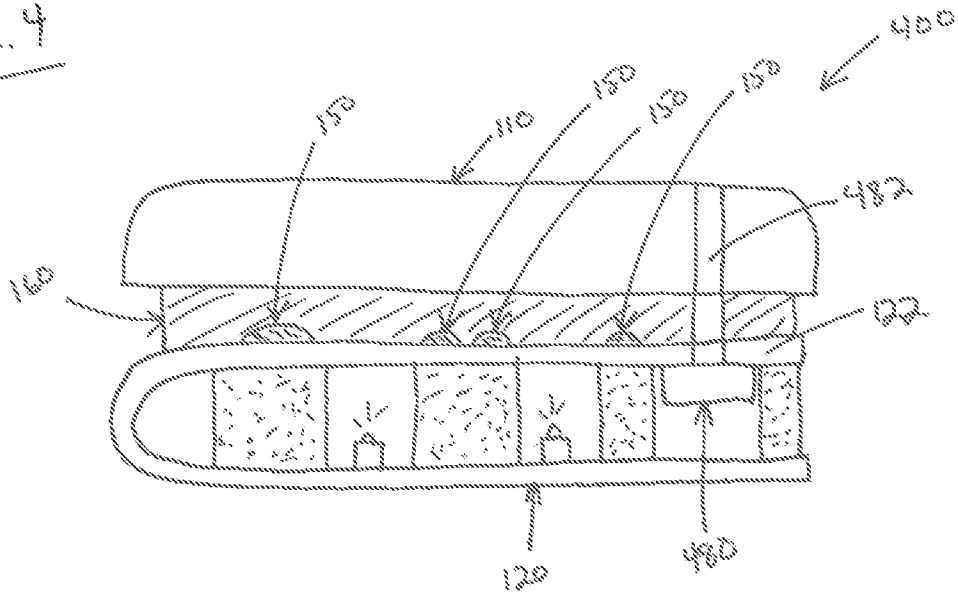
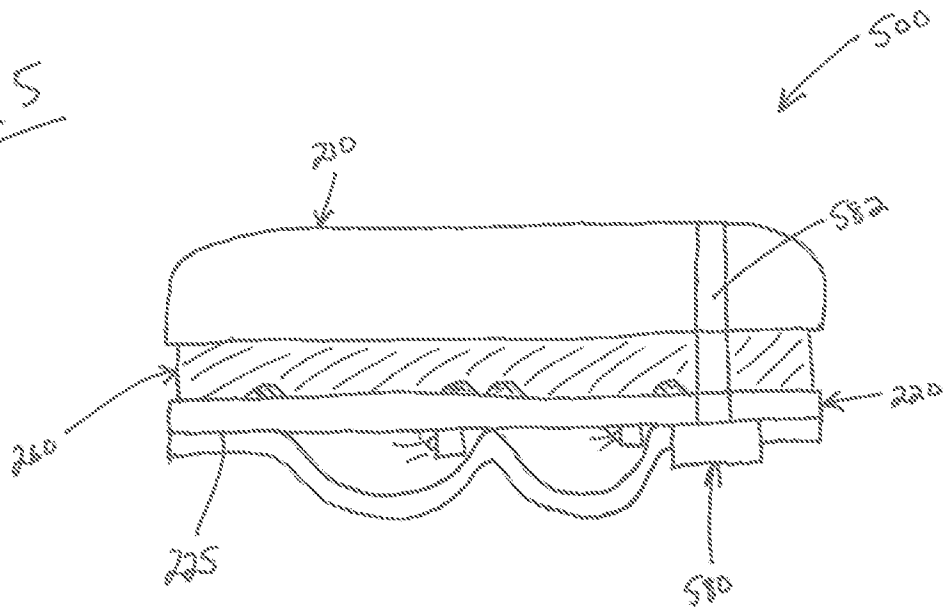

FIG. 5



INTERNATIONAL SEARCH REPORT

International application No.
PCT/US2018/064662**A. CLASSIFICATION OF SUBJECT MATTER****H03K 17/96(2006.01)i, H03K 17/94(2006.01)j**

According to International Patent Classification (IPC) or to both national classification and IPC

B. FIELDS SEARCHED

Minimum documentation searched (classification system followed by classification symbols)

H03K 17/96; B32B 3/00; B32B 7/02; F21V 7/04; G02F 1/017; G02F 1/1335; H01H 9/02; H03K 17/94

Documentation searched other than minimum documentation to the extent that such documents are included in the fields searched

Korean utility models and applications for utility models

Japanese utility models and applications for utility models

Electronic data base consulted during the international search (name of data base and, where practicable, search terms used)

eKOMPASS(KIPO internal) & Keywords: user interface device, lens, graphic, transparent circuit film, light emitting diode (LED), silver conductor, transparent pressure-sensitive adhesive, backlit

C. DOCUMENTS CONSIDERED TO BE RELEVANT

Category*	Citation of document, with indication, where appropriate, of the relevant passages	Relevant to claim No.
A	US 2015-0062490 A1 (JIN HYUK KWON) 05 March 2015 See paragraphs [0033]-[0045] and figure 1.	1-17
A	US 2009-0162617 A1 (YUTAKA MOROISHI et al.) 25 June 2009 See paragraphs [0067]-[0069], [0121] and figure 5.	1-17
A	US 2016-0103365 A1 (LG DISPLAY CO., LTD.) 14 April 2016 See paragraphs [0030]-[0072] and figures 1-2.	1-17
A	US 2006-0268567 A1 (JUN HO JANG et al.) 30 November 2006 See paragraphs [0035]-[0048] and figures 3-7.	1-17
A	US 2007-0209916 A1 (PAUL T. CLEGG et al.) 13 September 2007 See paragraphs [0111]-[0121] and figure 26.	1-17

 Further documents are listed in the continuation of Box C. See patent family annex.

* Special categories of cited documents:

"A" document defining the general state of the art which is not considered to be of particular relevance

"E" earlier application or patent but published on or after the international filing date

"L" document which may throw doubts on priority claim(s) or which is cited to establish the publication date of another citation or other special reason (as specified)

"O" document referring to an oral disclosure, use, exhibition or other means

"P" document published prior to the international filing date but later than the priority date claimed

"T" later document published after the international filing date or priority date and not in conflict with the application but cited to understand the principle or theory underlying the invention

"X" document of particular relevance; the claimed invention cannot be considered novel or cannot be considered to involve an inventive step when the document is taken alone

"Y" document of particular relevance; the claimed invention cannot be considered to involve an inventive step when the document is combined with one or more other such documents, such combination being obvious to a person skilled in the art

"&" document member of the same patent family

Date of the actual completion of the international search

05 April 2019 (05.04.2019)

Date of mailing of the international search report

05 April 2019 (05.04.2019)

Name and mailing address of the ISA/KR

International Application Division
Korean Intellectual Property Office
189 Cheongsa-ro, Seo-gu, Daejeon, 35208, Republic of Korea

Facsimile No. +82-42-481-8578

Authorized officer

KANG, Sung Chul

Telephone No. +82-42-481-8405



INTERNATIONAL SEARCH REPORT

Information on patent family members

International application No.

PCT/US2018/064662

Patent document cited in search report	Publication date	Patent family member(s)	Publication date
US 2015-0062490 A1	05/03/2015	KR 10-1348565 B1	16/01/2014
		KR 10-2013-0083807 A	23/07/2013
		WO 2013-105710 A1	18/07/2013
US 2009-0162617 A1	25/06/2009	CN 101542195 A	23/09/2009
		CN 101542195 B	05/12/2012
		CN 102654261 A	05/09/2012
		CN 102654261 B	15/10/2014
		EP 2028412 A1	25/02/2009
		EP 2028412 B1	10/04/2013
		EP 2544044 A1	09/01/2013
		EP 2544044 B1	17/09/2014
		JP 2008-243803 A	09/10/2008
		JP 2009-075595 A	09/04/2009
		JP 2009-076463 A	09/04/2009
		JP 2011-155010 A	11/08/2011
		JP 2012-004127 A	05/01/2012
		JP 4228026 B2	25/02/2009
		JP 4700722 B2	15/06/2011
		JP 4782183 B2	28/09/2011
		JP 5248642 B2	31/07/2013
		KR 10-1064096 B1	08/09/2011
		KR 10-2009-0064350 A	18/06/2009
		TW 200905314 A	01/02/2009
TW 201312219 A	16/03/2013		
TW I427365 B	21/02/2014		
TW I502250 B	01/10/2015		
WO 2008-105423 A1	04/09/2008		
US 2016-0103365 A1	14/04/2016	JP 2016-075838 A	12/05/2016
		JP 6401994 B2	10/10/2018
		KR 10-1657518 B1	19/09/2016
		KR 10-2016-0041753 A	18/04/2016
		US 9778507 B2	03/10/2017
US 2006-0268567 A1	30/11/2006	CN 1880836 A	20/12/2006
		CN 1880836 B	15/06/2011
		EP 1729058 A1	06/12/2006
		EP 1729058 B1	05/07/2017
		JP 2006-339151 A	14/12/2006
		JP 4246218 B2	02/04/2009
		KR 10-1093324 B1	14/12/2011
		KR 10-2006-0123965 A	05/12/2006
		US 7427145 B2	23/09/2008
US 2007-0209916 A1	13/09/2007	AU 2002-254085 A1	12/09/2002
		US 2002-0117386 A1	29/08/2002
		US 2004-0074742 A1	22/04/2004
		US 2004-0163936 A1	26/08/2004

INTERNATIONAL SEARCH REPORT

Information on patent family members

International application No.

PCT/US2018/064662

Patent document cited in search report	Publication date	Patent family member(s)	Publication date
		US 2007-0209912 A1	13/09/2007
		US 2007-0209913 A1	13/09/2007
		US 6660948 B2	09/12/2003
		US 6930260 B2	16/08/2005
		US 7361853 B2	22/04/2008
		US 7414210 B2	19/08/2008
		US 7432460 B2	07/10/2008
		US 7432463 B2	07/10/2008
		WO 02-069480 A2	06/09/2002
		WO 02-069480 A3	01/05/2003