

J. Turney,

Stump Elevator.

N^o 71,088.

Patented Nov 19, 1867.

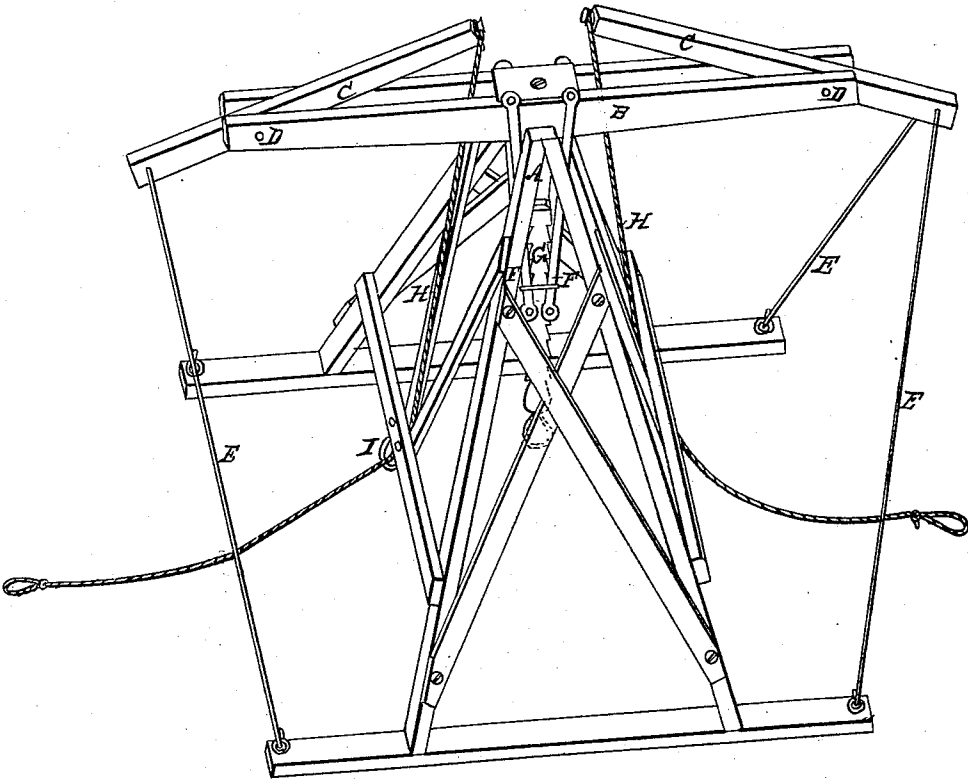

Witnesses
W. S. Sprague
Wm. A. King

Inventor
John Turney
by his atty

United States Patent Office

JOHN TURNER, OF GRAND HAVEN, MICHIGAN.

Letters Patent No. 71,088, dated November 19, 1867.

IMPROVEMENT IN STUMP-EXTRACTOR.

The Schedule referred to in these Letters Patent and making part of the same.

TO WHOM IT MAY CONCERN:

Be it known that I, JOHN TURNER, of Grand Haven, in the county of Ottawa, in the State of Michigan, have invented a new and useful Improvement in Stump-Extractors; and I do declare that the following is a true and accurate description thereof, reference being had to the accompanying drawings, and to the letters of reference marked thereon, and being a part of this specification.

I will now describe the manner of building my machine, so that those skilled in the art can manufacture it, especial reference being had to the drawings.

A is a proper and suitable frame, to sustain the working parts of the machine. On the top of this frame A, I hang the working-beam B. To the outer ends of this working-beam A, I attach the levers C C, hung upon proper bearings D D. One end of these levers C C is held firmly in place, and attached to the bottom of the frame A by the braces E E. From the centre of the working-beam B, I suspend the links F F, the lower ends of which catch and hold the sides of the double rack G. H H are chains or ropes, firmly attached to the inner ends of the levers C C, and then pass downwards and through the blocks I I.

When I wish to use my machine, I draw it astride the stump to be operated upon; then pass a bull-chain around the stump, and attach the chain to the hook K, which is fastened to the bottom of the double rack G. Then I hitch a horse to each of the chains or ropes H H. I start up one horse, who, drawing on the rope, depresses simultaneously the inner end of the lever C and the outer end of the beam B. By this means one of the links F F, opposite the side being pulled upon, drops into the next lower catch in the rack. Then I start up the other horse, when the same operation takes place; and so on alternately, until the stump is lifted out of the ground.

What I claim as my invention and desire to secure by Letters Patent, is—

The combination of the frame A with the working-beam B, the levers C C, hung upon the bearings D D, the braces E E, the links F F, the double rack G, the chains or ropes H H, the blocks I I, and the hook K, all arranged substantially as described, for the purpose designed.

JOHN TURNER.

Witnesses:

H. S. SPRAGUE,
WM. A. KRAG.