



(51) International Patent Classification:

B31F 1/00 (2006.01) *B32B 29/08* (2006.01)
B31B 1/00 (2006.01) *B65D 5/42* (2006.01)
B31B 1/25 (2006.01) *B65H 45/12* (2006.01)
B31F 1/08 (2006.01)

(21) International Application Number:

PCT/US2017/027614

(22) International Filing Date:

14 April 2017 (14.04.2017)

(25) Filing Language:

English

(26) Publication Language:

English

(30) Priority Data:

15/134,176 20 April 2016 (20.04.2016) US

(71) Applicant: **SCORRBOARD, LLC** [US/US]; 1100 SW 27th Street, Renton, WA 98057 (US).

(72) Inventor: **GREENFIELD, Giles**; 1100 SW 27th Street, Renton, WA 98057 (US).

(74) Agent: **JABLONSKI, Kevin, D.**; c/o Lane Powell PC, 1420 Fifth Avenue, Suite 4200, P.O. Box 91302, Seattle, WA 98111-9402 (US).

(81) Designated States (*unless otherwise indicated, for every kind of national protection available*): AE, AG, AL, AM, AO, AT, AU, AZ, BA, BB, BG, BH, BN, BR, BW, BY, BZ, CA, CH, CL, CN, CO, CR, CU, CZ, DE, DJ, DK, DM, DO, DZ, EC, EE, EG, ES, FI, GB, GD, GE, GH, GM, GT, HN, HR, HU, ID, IL, IN, IR, IS, JP, KE, KG, KH, KN, KP, KR, KW, KZ, LA, LC, LK, LR, LS, LU, LY, MA, MD, ME, MG, MK, MN, MW, MX, MY, MZ, NA, NG, NI, NO, NZ, OM, PA, PE, PG, PH, PL, PT, QA, RO, RS, RU, RW, SA, SC,

SD, SE, SG, SK, SL, SM, ST, SV, SY, TH, TJ, TM, TN, TR, TT, TZ, UA, UG, US, UZ, VC, VN, ZA, ZM, ZW.

(84) Designated States (*unless otherwise indicated, for every kind of regional protection available*): ARIPO (BW, GH, GM, KE, LR, LS, MW, MZ, NA, RW, SD, SL, ST, SZ, TZ, UG, ZM, ZW), Eurasian (AM, AZ, BY, KG, KZ, RU, TJ, TM), European (AL, AT, BE, BG, CH, CY, CZ, DE, DK, EE, ES, FI, FR, GB, GR, HR, HU, IE, IS, IT, LT, LU, LV, MC, MK, MT, NL, NO, PL, PT, RO, RS, SE, SI, SK, SM, TR), OAPI (BF, BJ, CF, CG, CI, CM, GA, GN, GQ, GW, KM, ML, MR, NE, SN, TD, TG).

Declarations under Rule 4.17:

— *as to applicant's entitlement to apply for and be granted a patent (Rule 4.17(ii))*

Published:

— *with international search report (Art. 21(3))*

(54) Title: SYSTEM AND METHOD FOR PRODUCING AN ARTICULATING BOARD PRODUCT HAVING A FACING WITH SCORE LINES IN REGISTER TO FLUTING

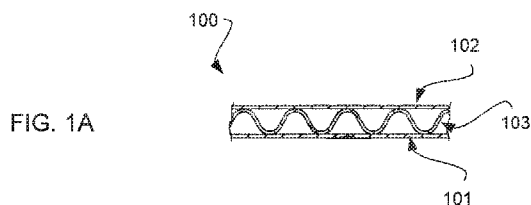

(57) Abstract: A system and method for producing a board product made from paper products that have a pre-scored facing in addition to a medium (sometimes called fluting). Conventional corrugated board may feature a cross-corrugated medium and one or more facing that have no score lines that are imprinted (at least prior to assembly with the corrugated medium). Such a conventional board product may be inferior because any score lines that are imprinted will damage the underlying corrugated medium in some manner. A breakdown in the strength of the underlying medium leads to poor precision when the eventual board product is scored, cut, and bent. A lack of precision in folding a board product is known as fishtailing as any articulated portion of the board product may not maintain a precise plane of articulation when bent. Hence, the articulated portion "fishtails" out of alignment. Having precisely located impression Sines in register to underlying flutes of a medium ensures correct and precise articulation.



SYSTEM AND METHOD FOR PRODUCING AN ARTICULATING BOARD PRODUCT HAVING A FACING WITH SCORE LINES IN REGISTER TO FLUTING

BACKGROUND

[1] Modern paper-making techniques use paper machines at paper mills to produce rolls of paper that, in turn, can be used by board makers to produce board products (*i.e.*, corrugated board). As a result, rolls of paper may be produced from machines that operate continuously. Modern paper machines typically produce paper from a number of substances including wood pulp that comprise wood fibers (although other fibers may also be used). These fibers tend to be elongated and suitable to be aligned next to one another. The fiber starts as a slurry that can be fed onto a moving screen from a head box of the paper machine. In modern paper machines, the fibers tend to align with each other and align with a direction in which the screen is moving. This alignment direction of underlying fibers is called the major direction of the paper and is in line with the machine direction. Thus, the major direction is often simply called the machine direction (MD) and the paper that is produced has an associated MD value.

[2] When paper is used to make a board product, portions or layers of the board product may be corrugated. Conventional corrugating machines will corrugate the underlying paper product in the cross direction (CD) of the paper thereby failing to take advantage of the natural strength bias of the paper in the machine direction. Further, the greater natural strength qualities of paper in the machine direction are left unharnessed by cross corrugation techniques in board making solutions. Further yet, conventional corrugated medium includes flutes that take on a sinusoidal shape because of the shape of the protrusions in a conventional pair of corrugating rolls. As a result, companies that

produce conventional board products remain entrenched in old production processes that limit the strength of the board product.

BRIEF DESCRIPTION OF THE DRAWINGS

[3] Aspects and many of the attendant advantages of the claims will become more readily appreciated as the same become better understood by reference to the following detailed description, when taken in conjunction with the accompanying drawings, wherein:

[4] **FIGs. 1A-1B** are views of a corrugated single wall conventional board product before and after major fold articulation without benefit of score lines in one or more facings.

[5] **FIGs. 2A-2C** show various states of a blank having slots cut and conventional impression lines such that the blank may be manipulated into a container.

[6] **FIG. 3** is an isometric cutaway view of a scored facing that may be part of one or more board products according to one or more embodiments of the subject matter disclosed herein.

[7] **FIG. 4** is an isometric cutaway view of an embossed medium that may be part of one or more board products according to one or more embodiments of the subject matter disclosed herein.

[8] **FIG. 5** is an isometric cutaway view of a board product having the scored facing of **FIG. 3** and medium of **FIG. 4** according to an embodiment of the subject matter disclosed herein.

[9] FIGs. 6A-6C are a series of views of the board product of FIG. 5 being articulated with benefit of score lines in one or more facings according to an embodiment of the subject matter disclosed herein.

[10] FIG. 7 shows a side-by-side comparison of an articulated conventional board product and an articulate board product of FIG. 5.

[11] FIGs. 8A-8B are views of a board product before and after articulation with benefit of one score line in one or more facings according to an embodiment of the subject matter disclosed herein.

[12] FIG. 9 is a diagram of aspects of a machine configured to produce the board product of FIG. 3 according to an embodiment of the subject matter disclosed herein.

DETAILED DESCRIPTION

[13] The following discussion is presented to enable a person skilled in the art to make and use the subject matter disclosed herein. The general principles described herein may be applied to embodiments and applications other than those detailed herein without departing from the spirit and scope of the present detailed description. The present disclosure is not intended to be limited to the embodiments shown, but is to be accorded the widest scope consistent with the principles and features disclosed or suggested herein.

[14] By way of overview, the subject matter disclosed herein may be directed to a system and method for producing a board product made from paper products that have a pre-scored facing in addition to a medium (sometimes called fluting) such that precise articulation may be induced. A conventional board product may feature a cross-

corrugated medium and one or more facings that have no score lines that are imprinted (at least prior to assembly with the corrugated medium). Such a conventional board product may be inferior because any score lines that are imprinted will damage the underlying corrugated medium in some manner. A breakdown in the strength of the underlying medium leads to poor precision when the eventual board product is scored, cut, and folded. A lack of precision in a folded container leads to gap variation and fishtailing, as any articulated portion of the board product may not maintain a precise plane of articulation when folded. Hence, the articulated portion "fishtails" out of alignment.

[15] Having a pre-scored facing (sometimes called wall or liner) with strategically placed score lines (e.g., strategically placed with respect to an eventual articulation point and/or with respect to underlying flutes in an attached medium), eliminates problems with fishtailing. This is because the pre-score lines bias the facing to give way at the score lines when articulated. As a result, the fold line on the facing is precisely aligned along the pre-score line (making any fold aligned with a desired box corner pattern) as well as precisely placed with respect to any underlying flutes (making any fold also aligned with the flute pattern). The effects of pre-score lines in a facing may be enhanced when used in conjunction with an embossed medium that exhibit greater structural characteristics when compared to conventional cross-corrugated medium. These advantages and additional aspects of various embodiments of the subject matter disclosed herein are discussed below with respect to **FIGs. 1-8**.

[16] **FIGs. 1A-1B** are views of a conventional board product **100** before and after major fold articulation without benefit of score lines in one or more facings. As discussed briefly

in the summary, score lines will assist with board articulation such that articulation of the board product is precise. In an effort to show problems of conventional board product **100**, the views in **FIGs. 1A-1B** are shown and then various problems with an eventual container are shown in **FIGs. 2B-2C** to illustrate the effects of the problems of the conventional board product **100**. A conventional board product **100** may have some form of a medium **103** that is attached to a first facing **101** and a second facing **202**. Of course, these facings do not have any score lines predisposed. As such, certainly there are no score lines in register to the flutes of the medium **103**. Further, the medium **103** may also be a conventional cross-corrugated medium having flutes aligned in the cross direction (discussed further below) of the paper of the medium **103**.

[17] When one wishes to articulate the board product **100**, which is often the case when the board product is eventually used for containers and boxes, a machine may produce a score line (or sometimes, an indentation, an impression, or some other form of marking in order to induce a fold line) at a line intended for articulation (e.g., intended to be a corner or fold point without reference to underlying flutes). Thus, in looking at **FIG. 1B**, a fold may be intended at point **104**. As can be seen, the board product **100** is being articulated (at approximately 180 degrees in this view). A 180 degree fold is sometimes called a major fold and may be a manufacturer requirement for producing folded box blanks. A blank is an unfolded container in a flat open state (as shown **FIG. 2A**) that is manufactured to eventually be manipulated into a container or box. A conventional regular slotted container (RSC) blank is discussed below with respect to **FIGs. 2A-2C**.

[18] When a machine makes an impression in the board product in production of a blank, a mechanical impression collar may be used to impress a crease line at a specific

location. This location is in relation to an edge of the blank (e.g., 36 inches from the edge of the blank, as but one example); such a location, in conventional methods, is not in relation to underlying flutes of the medium. As a consequence, when the mechanical impression collar impresses a fold line, any underlying flutes that happen to be within the impression area are crushed. By crushing the interior flutes, a significant localized amount of board structure is compromised. Thus, the fold point **104** begins to flex inward and the exterior fold point begins to stretch out around the fold. The interior flutes around the fold begin to narrow as the two legs begin to come together.

[19] **FIG. 1B** shows the conventional board product in full 180 degree articulation. The first facing **101** has been folded in half so as to come into contact with itself. The second facing **102** has stretched enough at point **104** to accommodate the additional distance around the 180 degree fold point **104**. As can be seen, the interior fluting of the medium **103** loses structure as the localized flutes are significantly damaged. Further, the second facing **102** may often fracture at the 180 degree fold point **104**. Such fracturing weakens the board product at point **104** significantly. As a result of the fold point **104** causing a breakdown in medium structure as well as possible fracturing in one or more facings, additional undesirable variations in the eventual container or box product will exhibit. These undesired variations are discussed next with respect to **FIGs. 2A-2C**.

[20] **FIGs. 2A-2C** show various states of a blank **105** having slots **106** cut and conventional impression lines **108b**, **108c**, **108d** and **108e** such that the blank **105** may be manipulated into a container. In **FIG. 2A**, the blank **105** is shown where a board product may be altered to have the desired features, such as slots and impression lines. Thus, the board product may have a pairs of slots **106** that have been cut along eventual

fold lines **108b**, **108c**, **108d** and **108e**. The slots **106** should be precisely aligned and sized for the intended purpose and the dimensions shown in **FIG. 2A** are for illustrative purpose only as but one example of a flat blank **105**. As a typical requirement for the end user of a blank, the left-most panel **107a** may be folded (at fold line **108b**) 180 degrees to lay flat on top of panel **107b**. This 180 degree fold is called a major fold. Similarly, the right-most panel **107d** may be folded (at fold line **108d**) 180 degrees to lay flat on top of panel **107c**. Once folded, the ends **108a** and **108e** of the blank **105** may then be situated adjacent to each other with a glue lap **109** positioned to in an overlapping manner such that the edge **108a** may be adhered to the glue lap **109**. When precisely aligned, the edge **108a** is positioned next to the edge **108e** such that the distance between edges **108a** and **108e** is the same width of other slots **106** in the blank **105**.

[21] When articulated in the manner, the knocked down container blank **105** may be in a folded condition to be fed into a machine for erecting a box or container from the blank. Such an articulation may be useful for packaging and shipping the resultant knocked-down container blank **105** prior to being erected into the box or container. These articulations, when performed on conventional board product, often lead to undesired variations as shown in **FIG. 2B-2C**.

[22] A first undesired variation is shown in **FIG. 2B** and is called a gap variation. Gap variation may occur when the edge **108a** and **108e** are not precisely aligned adjacent to each so as to exhibit a gap that is the same as the width of other slots when the glue lap **109** is adhered to the panel **107a**. The gap may be too narrow if the major folds at folds lines **108b** and **108d** are rolled inward and may be too wide if the major folds at folds lines **108b** and **108d** are rolled outward. In this view, one can see that the panel **107a** has been

articulated 180 degrees along major fold line **108b** and panel **107d** has been articulated 180 degrees along major fold line **108d**. However, the glue lap **109** does not significantly overlap the panel **107a** and the edges **108a** and **108e** are too far apart. Without precise overlap, the edges **108a** and **108e** with glue lap **109** may not be in position to be properly adhered to each other. This gap variation may be caused by compromised major fold lines **108b** and **108d** because of a lack of precision in the fold lines. Another variation that is not shown in the figures may be when the edge **108a** and **108e** are too close or even overlap. Gap variations may be characterized as the glue lap having too much overlap or not enough overlap (or even no overlap) and is a variability that leads to undesired problems in the finished container.

[23] A second undesired variation is shown in FIG. 2C and is called "fishtailing." Fishtailing occurs when the fold results in one or more panels being not parallel with other panels. In the example shown in FIG. 2C, the panel **107a** is not parallel with the panel **107d**. As such, the edge **108a** is also not parallel with the edge **108e** and the glue lap will not interface with the panel **107a** in a precise manner. Here, the major fold **108b** may be precise enough, but the major fold **108d** is not precise and results in the folded over panel **107d** fishtailing out of alignment. This results in problems for set-up machines that erect the RSC blanks into boxes or containers.

[24] The problems shown in FIGs. 2A-2C typically occur because of scoring and folding conventional board product without regard to the position of any underlying flutes in the medium. In addition, after-assembly scoring (e.g., scoring that occurs after a board product is assembled) causes damage to flutes as collateral flutes becomes partially or completely crushed to prevent the flutes from tracking the fold line on either side of the

desired fold position. Not only does this degrade board/box strength, it allows for irregular folding (rolling scores), resulting in gap variation, as measured at the manufacturers joint. These and other problems may be overcome by pre-scoring facings and then assembling a board product with score lines in register to the underlying flutes of the medium.

[25] Prior to discussing the various embodiments, a brief discussion about cross corrugating and linear embossing is presented. As has been briefly stated above, conventional board products include a conventionally produced corrugated medium (sometimes called a corrugated fluting), *e.g.*, a cross-corrugated medium. A cross-corrugated medium has flutes formed perpendicular to most underlying fibers of the paper product. This results in flutes that are not aligned with the majority of underlying fibers and, therefore, do not take advantage of the natural strength of the MD value of the paper (when compared to the CD value). Such a failure to harness the MD value of the paper leads to loss of opportunity in the manufacturing of board products when specific board strength is to be realized. That is, it will necessarily take more paper (heavier paper, larger flutes, and the like) to realize the required board strength.

[26] A linearly-embossed medium is different from a cross-corrugated medium in that the induced flutes are aligned with the MD value of the paper product. This results in flutes that are aligned with the majority of underlying fibers and, therefore, take advantage of the natural strength of the MD value of the paper (when compared to the CD value). Harnessing the MD value of the paper leads to efficiencies in the manufacturing of board products when specific board strength is to be realized. That is, it will necessarily take less paper (lighter paper, smaller flutes, and the like) to realize the required board strength. Aspects of making, producing, and using linearly embossed mediums are

discussed in greater detail in U.S. Patent Application No. 15/077,250 entitled "SYSTEM AND METHOD FOR INDUCING FLUTING IN A PAPER PRODUCT BY EMBOSSING WITH RESPECT TO MACHINE DIRECTION" and filed on March 22, 2016, which is incorporated herein by reference in its entirety and for all purposes. Some aspects of a linearly embossed medium are discussed below with respect to **FIG. 4**. Next, aspects of a pre-scored liner are discussed with respect to **FIG. 3**.

[27] **FIG. 3** is an isometric cutaway view of a scored facing **110** that may be part of one or more board products according to one or more embodiments of the subject matter disclosed herein. In this embodiment, a facing may be produced having a MD value in the MD direction **122** and having a weight and materials commonly used for a board product facing. The facing **110** may sometimes be called a liner or wall as this layer of a board product is often an innermost portion of the board product. As was briefly discussed above, a facing **110** may often be scored to elicit articulation along a particular line. However, if the facing has already been coupled with one or more additional layers of a board product (e.g., a corrugated medium, an embossed medium, another facing, and the like), then the scoring process will not only leave an impression on the facing **110**, but also on any other layer in the board product. As shown in **FIGs. 2B-2C**, such after-assembly scoring leads to undesired variations and structural damage of the additional layers of the board product, which, in turns, weakens the board product significantly at the articulation point.

[28] The embodiment of **FIG. 3**, however, may be a facing **110** that has undergone a pre-scoring process such that score lines **115** are impressed into the facing **110** prior to the facing **110** being combined with any other paper product (e.g., any other layer of a

board product). In the embodiment shown in **FIG. 3**, the pre-score lines **115** are equidistant with respect to each other and may be strategically spaced to also be in alignment with an eventual embossed medium (not shown in **FIG. 3**) having flutes of a similar specific pitch dimension. Further, the score lines may be continuous impressions into the facing **110**. However, the "score" line may be any localized weakening of the facing **110** at the desired point of fold of the board product that is strategically placed with respect to the underlying flutes. In other embodiments then, the score may be a crease impression (continuous linear or intermittent), partial slit through the facing **110** (continuous linear or intermittent), perforation in the facing **110**, and the like.

[29] In other embodiments not shown, the pre-score lines **115** may be less than consistent across a facing **110**. For example, two score lines **115** may be grouped together at approximately five mm apart from each other and then spaced apart from another grouping of two of these five-mm-spaced score lines. In yet another example, only a single grouping of scores may be present on a facing or even a single score line. Although five mm intervals are given as an example, any width of interval may be possible and common intervals will match common flute profiles, such as C-Flute, B-Flute, R-Flute and the like. These groupings may correspond to anticipated articulation points for a specific box machine. However, for the purposes of efficient production of a consistent facing **110**, score lines **115** may be impressed by a scoring machine at strategically selected intervals (e.g., every five mm) such that any portion of the pre-scored facing **110** may be combined with other layers of an eventual board product. The embossed medium **130** of **FIG. 4** may be one such additional layer.

[30] FIG. 4 is an isometric cutaway view of an embossed medium 130 that may be part of one or more board products according to one or more embodiments of the subject matter disclosed herein. This diagram shows an isometric view of a portion of an embossed medium 130 that may be formed from an embossing process. That is, flutes 131 are formed from passing the initial paper product through embossing rolls using a linear-embossing technique such that the flutes 131 are formed congruent with a majority of underlying fibers 125 of the paper. The flutes 131 are also formed congruent with the machine direction 122. A linearly-embossed medium 130 harnesses the natural strength of the paper in the machine direction 122 as the flutes 131 are formed in the machine direction 122 of the paper (e.g., congruent with a majority the underlying fibers 125). Therefore, a linearly-embossed medium 130 harnesses the natural strength of the paper in the machine direction 122. Such an embossed medium 130 may be a component/layer of a board product as discussed below with respect to FIG. 5.

[31] Further, as is shown in FIG. 4, the flutes 131 may form a triangular pattern when viewed from a cutaway perspective. This flute pattern having a triangular repeating shape is referred to as a flute profile. This flute profile provides an improvement in structural integrity of the embossed medium 130 when compared to a flute profile the exhibits a curvilinear or sinusoidal flute profile. Such a curvilinear or sinusoidal flute profile is prevalent in conventional cross-corrugated mediums. Therefore, the triangular flute profile as shown in FIG. 4 is also superior to corrugated mediums with respect to board strength and structural integrity. The flute profile exhibits apexes 132 that may be adhered to a facing (not shown). The apexes may be spaced apart in a repetitive manner at a specific distance (such as five mm, for example). As will be discussed next, when

coupled to a matching pre-scored facing **110** of **FIG. 3**, the apexes **132** of the embossed medium **130** may be precisely aligned in a desired manner to yield precise and less damaging articulation of any resulting board product.

[32] **FIG. 5** is an isometric cutaway side view of a board product **300** having the scored facing **110** of **FIG. 1** and the medium **130** of **FIG. 4** according to an embodiment of the subject matter disclosed herein. In this embodiment, the board product **300** includes three layers: the first facing **110**, the medium **130**, and a second facing **140**. As is shown, the first facing **110** may form an inner wall (although the top/bottom direction reference to alignment of the board product **300** is arbitrary) that is coupled to one side of the embossed medium **130**. The coupling may be through an adhesive applied to the apex of each flute on the top-side of the medium **130** such that the facing **110** is glued to the medium **130** where adhesive is applied. In other embodiments, glue may be applied to the entirety of the facing **110** prior to being coupled to the medium **130**.

[33] Likewise, a second facing **140** may form a bottom-side outer wall (again, the top/bottom direction reference is arbitrary) that is coupled to an opposite side of the embossed medium **130**. The coupling may be through an adhesive applied to the apex of each flute on the bottom-side of the embossed medium **130** such that the facing **140** is glued to the embossed medium **130** where adhesive is applied. In other embodiments, glue may be applied to the entirety of the facing **140** prior to being coupled to the embossed medium **130**.

[34] The score lines **115** are aligned in the direction of underlying flutes of the embossed medium. Both the score lines and the flutes are also aligned with the machine direction **122** of the underlying paper in the scored facing **110**, the facing **140** and the

medium **130**. Further, in this embodiment, the score lines **115** of the scored facing **110** are aligned in a manner such that the score lines are placed equidistant from respective apex locations of the affixed embossed medium. For example, if the top-side apexes of the embossed medium **130** are spaced five mm apart from each other, then the score lines **115** are also spaced five mm apart from each other, but offset by 2.5 mm. That is, for every pair of top-side apexes that are five mm apart, the affixed facing **110** features a score line **115** half way between each pair of top-side apexes at approximately 2.5 mm from each one.

[35] With precisely placed score lines in a facing that is affixed to a medium having linear flutes, precise articulation lines may be induced. That is, if one were to fold the board product **300**, the scored facing would give way along one or more score lines in a precise manner. That is, the fold would precisely lie in a single plane that is normal to the score line being articulated. Such a fold may be precise and will serve to prevent the articulation direction from veering out of the normal to the plane of the score line. In other embodiments (not shown), the bottom-side facing **140** may also be pre-scored with a similar pattern of score lines precisely aligned with bottom-side apexes of the embossed medium **130**. Further, the pre-scored lines in any facing may cover less than all of the area of the facing (e.g., only score lines in anticipated articulation points).

[36] When all three layers are assembled and affixed, the resultant board product **300** is superior to conventional board product because of several factors. First, because the flutes of the embossed medium **130** are strategically aligned with respect to the score lines of the pre-scored facing **110**, any articulation of the board product will be precise resulting in accuracy in the finished box container. Such precision prevents gap variation

and fishtailing. Further, the linearly embossed medium **130** includes a flute profile that exhibits superior strength because of the leg structures of the triangular nature of each flute. Further yet, adhesive may be continuously and uniformly applied to each apex in a predictable manner with greater precision as portions of the adhesive will not spill over to the legs as may be the case with sinusoidal apexes having no flat receiving area. Lastly, a pre-scored facing **110** prevents having a scoring step after board assembly that leads to damage of underlying layers (e.g., the embossed medium **130**) when conventional board scoring techniques are used.

[37] FIGs. **6A-6C** are a series of views of the board product **300** of FIG. **5** being articulated with benefit of score lines in one or more facings according to an embodiment of the subject matter disclosed herein. In FIG. **6A**, the board product **300** is shown from an edge view so as to better illustrate what happens when the board product **300** is articulated. As shown, the board product **300** includes a first facing **110**, a second facing **140** and a medium **130**. The medium **130** is disposed between the first facing **110** and the second facing **140**. The first facing may further include score lines **115**. In this example view of FIG. **6A**, the first facing **110** is shown facing down simply for illustrative purposes. Further, only two score lines **115** are shown for ease of illustration as there may be many more score lines in register to the flutes of the medium **130** including score lines on the second facing **140** as well. Further yet, the medium **130** is shown having a sinusoidal flute profile, though it is understood that any shape of flute profile may be used.

[38] In the next view of FIG. **6B**, the board product **300** has begun articulation. Here, the fold lines will follow precisely the score lines **115** in the facing **110**. Thus a first fold point **603** corresponds to a first score line **115** and a second point **604** corresponds to a

second score line. As can be seen in this view of **FIG. 6B**, an articulation that will result in an eventual 180 degree articulation will comprise two different folds of approximately 90 degrees each. Further, the first fold point **603** is located directly between two apexes (of downward facing flutes – *i.e.*, two apexes affixed to the first facing **110**) of the medium **130** such that the legs of this flute begin to move toward each other. As a result, a first stretch point **601** of the second facing **140** begins to form directly over the first fold point **603**. Similarly, the second fold point **604** is located directly between two apexes (of downward facing flutes – *i.e.*, two apexes affixed to the first facing **110**) of the medium **130** such that the legs of this flute also begin to move toward each other. As a result, a second stretch point **602** of the second facing **140** begins to form directly over the second fold point **604**.

[39] In **FIG. 6C**, the board product **300** is shown fully articulated to the 180 degree position. Thus, the first stretch point **601** and the second stretch point **602** are each approximately 90 degrees. Different from the conventional example of **FIGs. 1A-1B** where the stretch point folded a full 180 degrees, this embodiment accomplishes a full 180 degrees of board product articulation with only having approximately 90 degrees of fold causing a stretch at any given location. Having a full 180 degree articulation with only 90 degrees of stretch at any given point leads to less stress at the stretch points to underlying fibers in the facing **140**. This, in turn, leads to greater strength at corners of boxes and containers due to less stretch damage to the facing **140** and no loss of flute structure in the medium **130**.

[40] Further, the fold points **603** and **604** fold all the way into a respective flute such that secondary flutes are formed to provide additional corner structure from liner **110**.

That is, at the first fold point **603**, a first secondary fold flute **610** is formed from facing **110** inside of a first primary fold flute **605**. Likewise, a second secondary fold flute **611** is formed from facing **110** inside of a second primary fold flute **606**. Secondary flutes **610** and **611** provide additional corner strength in boxes and containers.

[41] FIG. 7 shows a side-by-side comparison of an articulated conventional board product **100** and an articulate board product **300** of FIG. 5. As can be seen, the conventional board **100** shows a distortion in the medium structure at and adjacent to the 180 degree articulation point. Here, the underlying flutes have been compromised because the fold point did not happen to line up with a respective flute in the medium. This corner will have demonstrably less predictability in folding. Differently, the embodiment of the board product with precisely located score lines exhibits the additional secondary flutes as discussed above with respect to FIG. 6C. This articulation point in the board product **300** will have superior strength when compared to the conventional example **100**.

[42] FIGs. 8A-8B are views of a board product before and after articulation with benefit of one score line in one or more facings according to an embodiment of the subject matter disclosed herein. In FIG. 8A, the board product **800** is shown from a edge view so as to better illustrate what happens when the board product **800** is articulated. As shown, the board product **800** includes a first facing **810**, a second facing **840** and a medium **830**. The medium **830** is disposed between the first facing **810** and the second facing **840**. The first facing may further include one score line **815**. In this example view of FIG. 8A, the first facing **810** is shown facing down simply for illustrative purposes. Further, only one score line **815** is shown that is precisely located below an apex of a flute in the

medium **830**. Further yet, the medium **830** is shown having a sinusoidal flute profile, though it is understood that any shape of flute profile may be used and the medium **830** may be embossed or corrugated.

[43] In the next view of **FIG. 8B**, the board product **300** has begun articulation. Here, the fold line will follow precisely the score line **815** in the facing **810**. Thus a first fold point **804** corresponds to a first score line **815**. As can be seen in this view of **FIG. 8B**, an articulation will result in an eventual approximately 90 degree articulation without damage to underlying flutes. Further, the fold point **804** is located directly between two apexes (of downward facing flutes – *i.e.*, two apexes affixed to the first facing **810**) of the medium **830** such that the legs of this flute begin to move toward each other. As a result, a stretch point **805** of the second facing **840** begins to form directly over the fold point **804**. With a precisely located score line **815**, a 90 degree fold may be realized without causing undesired damage to the flutes of the medium **830**. Additional aspects of various embodiments of board products are discussed next with respect to the machine of **FIG. 9**.

[44] **FIG. 9** is a diagram of aspects of a machine **500** configured to produce the board product **300** of **FIG. 5** according to an embodiment of the subject matter disclosed herein. The machine **500** may produce other embodiments as well including the embodiment of the board product **800** from **FIG. 8A**. The machine **500** includes three feed rolls **510**, **530**, and **540** of paper that are used to produce a board product. These feed rolls include a first facing feed roll **510**, an embossed medium feed roll **530**, and a second facing feed roll **540**. Note that the paper that is wound on the first facing feed roll **510** is prior to scoring and the paper that is wound on the embossed medium feed roll **530** is prior to

embossing. The weights and composition of the paper for each respective feed roll may be different and designed specifically for the respective purpose.

[45] The paper from each roll may be unwound from each respective roll and fed toward a combiner **550** that is configured to combine the various layers of paper together to form a resultant board product. Prior to entering the combiner **550**, at least some of the paper from the feed rolls may be passed through one or more stages for scoring the paper. Thus, the first facing feed roll **510** may feed paper into a scoring stage **590** that scores the paper with impressions in a precise manner. In other embodiments, the lines impressed upon the facing **110** may be perforations, intermittent cuts or some other form of localized weakening the facing **110** along a precise line. As the paper exits the scoring stage **590**, it becomes the scored facing **110** as discussed above with respect to **FIG. 3**. The scored facing **110** is then fed into the combiner **550** to be combined with other materials.

[46] Further, also prior to entering the combiner **550**, at least some of the paper from the feed rolls may be passed through one or more stages for forming the paper into a medium. As used herein and in the industry, a medium may refer to a paper product that has been formed into paper having flutes. Thus, the embossed medium feed roll **530** may feed paper into first and second embossing rolls **531a** and **531b** that are aligned with respect to each other. As the paper exits the embossing stage (e.g., embossing rolls **531a** and **531b**), it becomes the embossed medium **130** as discussed above with respect to **FIG. 4**. The embossed medium **130** is then fed into the combiner **550** to be combined with other materials.

[47] Once passed through the embossing rolls **531a** and **531b**, the embossed medium **130** may be passed to an applicator **570** for applying adhesive to the newly formed apexes. The applicator may include a device for identifying the locations of each apex and then aligning a series of adhesive dispensers with the identified apexes. In other embodiments, adhesive may be transferred to the flute tips with a glue roll or rolls where the paper contacts a glue film and adheres to the flute tips. In this manner, adhesive may be applied with precision in a continuous and uniform manner. Then, the first facing **110**, the embossed medium **130**, and the second facing **140** are combined in the combiner **550** using various techniques such as adhesion, curing, wetting, drying, heating, and chemical treatment. The resultant board product **300** features at least one scored facing precisely aligned with at least one linearly-embossed medium **130** wherein the board product may be articulated with accuracy.

[48] While the subject matter discussed herein is susceptible to various modifications and alternative constructions, certain illustrated embodiments thereof are shown in the drawings and have been described above in detail. It should be understood, however, that there is no intention to limit the claims to the specific forms disclosed, but on the contrary, the intention is to cover all modifications, alternative constructions, and equivalents falling within the spirit and scope of the claims.

What is claimed is:

1. A board product, comprising:
 - a facing having a plurality of impressions;
 - a medium coupled to the facing and having a plurality of flutes; and
 - an articulation point having a first impression aligned with a first flute and a second impression aligned with a second flute.
2. The board product of claim 1, wherein the articulation point is configured to articulate 180 degrees such that the first impression aligned with the first flute forms a first angle of approximately 90 degrees and the second impression aligned with the second flute forms a second angle of approximately 90 degrees.
3. The board product of claim 1, wherein the medium further comprises an embossed medium.
4. The board product of claim 1, wherein the medium further comprises a corrugated medium.
5. The board product of claim 1, wherein the medium further comprises a linearly embossed medium.

6. The board product of claim 1, wherein each of the plurality of impressions further comprises a score line.
7. The board product of claim 1, wherein each of the plurality of impressions further comprises a series of perforations.
8. The board product of claim 1, wherein the articulation point further comprises secondary flutes formed by the facing when the articulation point is articulated.
9. A board-making method, comprising:
 - forming impression lines in a paper facing;
 - combining the paper facing with a paper medium with a plurality of flutes to the paper facing; and
 - forming an articulation point in the combination wherein a first impression line is aligned with a first flute and a second impression line is aligned with a second flute.
10. The board-making method of claim 9, further comprising embossing the medium to form the plurality of flutes.
11. The board-making method of claim 9, further comprising corrugating the medium to form the plurality of flutes.

12. The board-making method of claim 9, wherein forming impression lines in the paper facing further comprises cutting intermittent perforations in a line in the paper facing.

13. The board-making method of claim 12, wherein forming impression lines in the paper facing further comprises impressing score lines in the paper facing.

14. The board-making method of claim 9, further comprising articulating the articulation point to form a first 90 degree fold at a first impression line and a second 90 degree fold at a second impression line.

15. The board-making method of claim 9, further comprising articulating the articulation point to form a first secondary flute from the paper facing at the first impression line and a second secondary flute from the paper facing at the second impression line.

16. The board-making method of claim 9, further comprising gluing the paper medium to the paper facing.

17. The board-making method of claim 9, further comprising affixing a second paper facing with respect to the paper medium.

18. A board-making machine, comprising:

an impression forming stage configured to impress a first impression line and a second impression line in a paper facing;

a medium forming stage configured to form a medium to include a plurality of flutes; and

a combining stage configured to couple the paper facing to the medium to form an articulation point such that the first impression line is aligned with a first flute and the second impression line is aligned with a second flute.

19. The board-making machine of claim 18, further comprising a plurality of feed rolls configured to feed paper to the impression forming stage and to the medium forming stage.

20. The board-making machine of claim 18, further comprising an articulation stage configured to articulate the articulation point to form a first 90 degree fold at a first impression line and a second 90 degree fold at a second impression line.

FIG. 1A

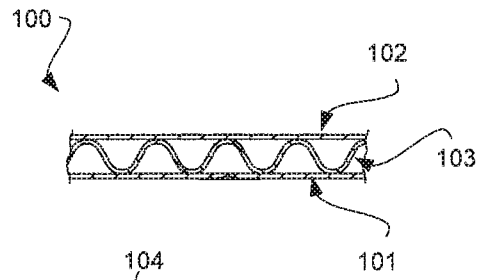

FIG. 1B

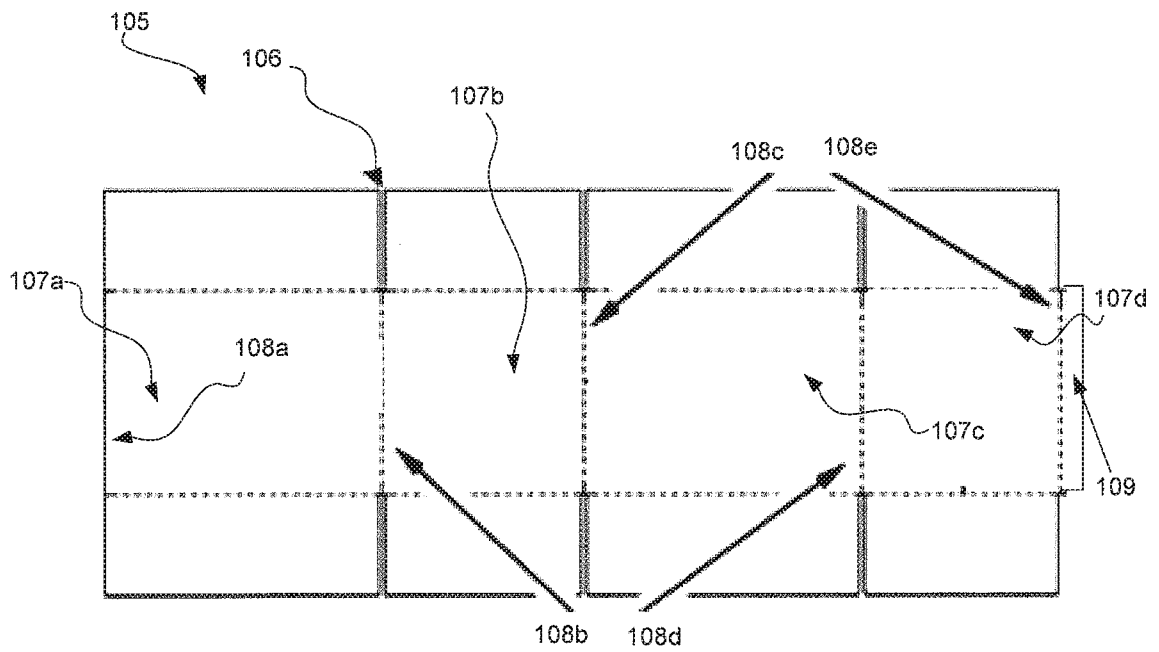
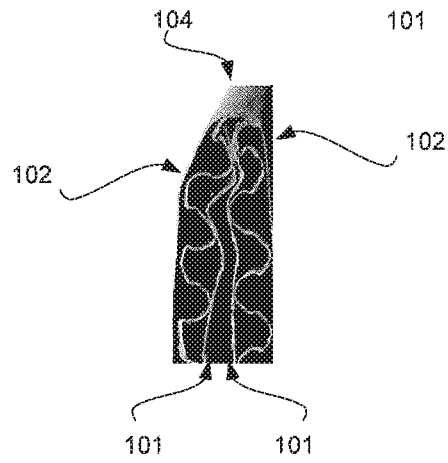

FIG. 2A

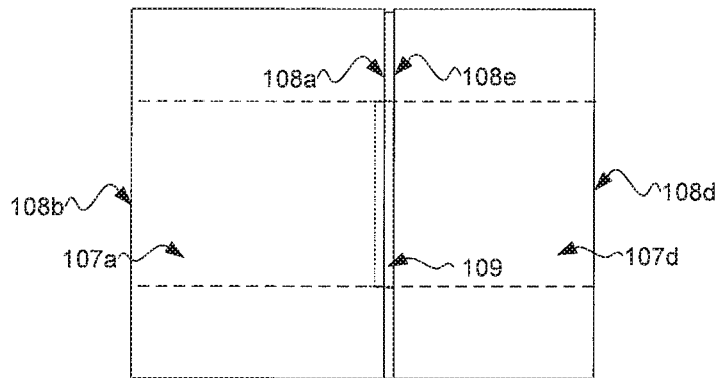

FIG. 2B

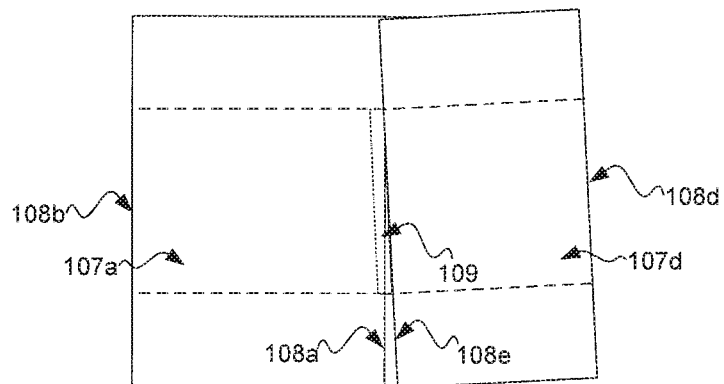

FIG. 2C

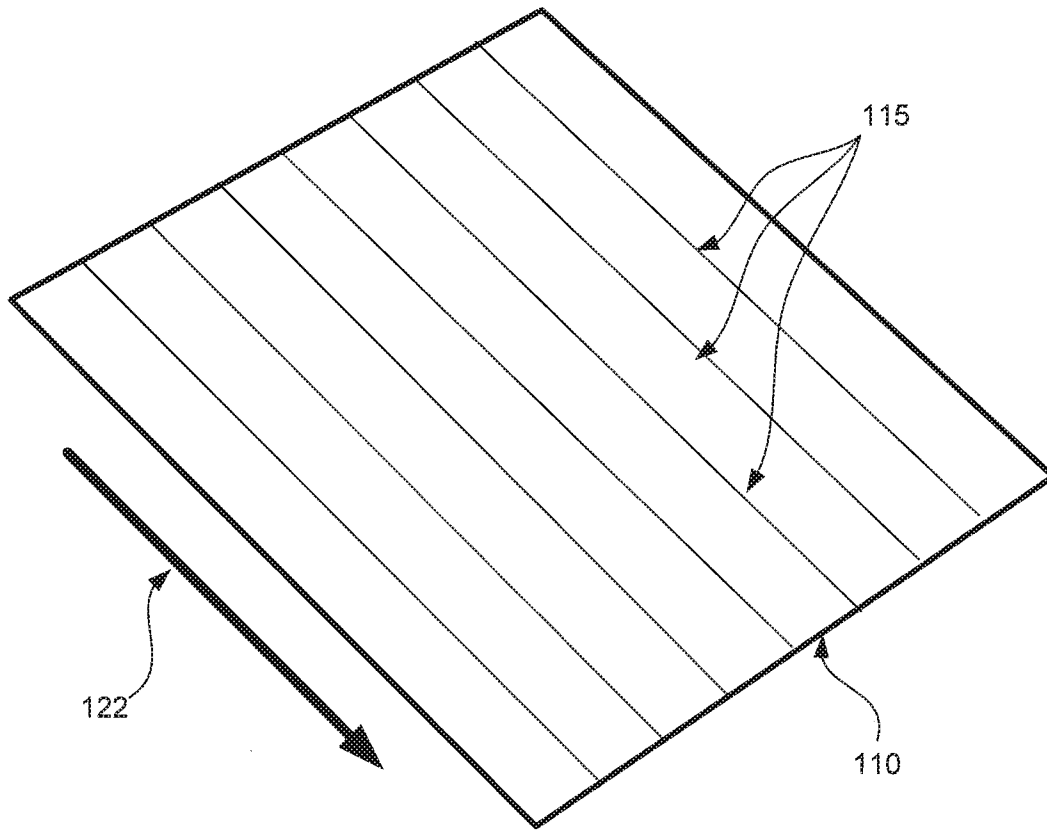

FIG. 3

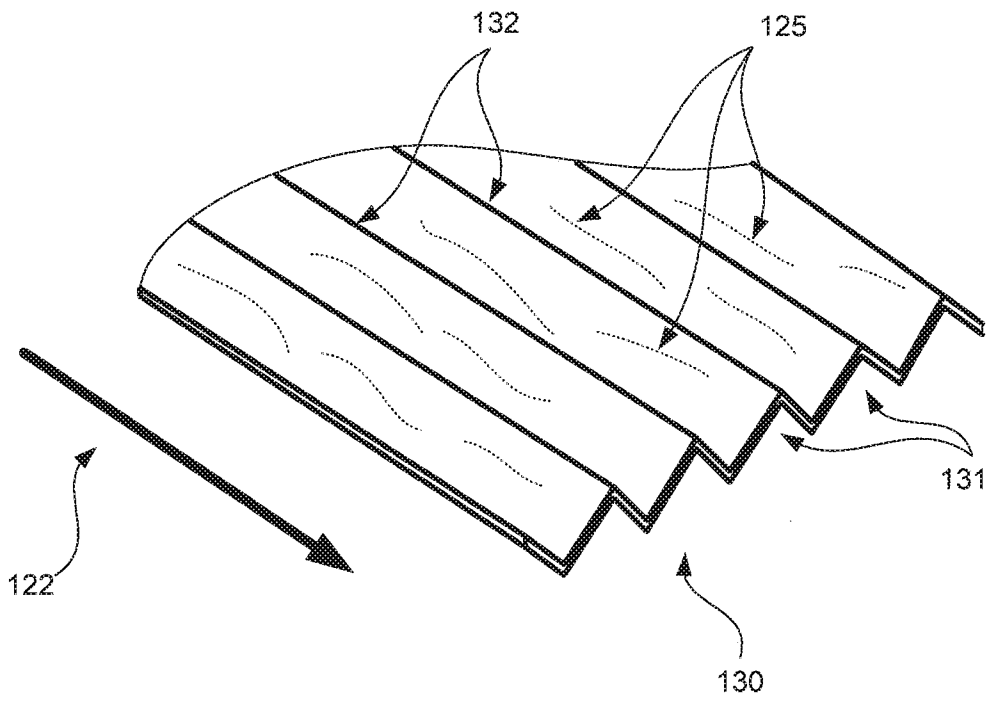

FIG. 4

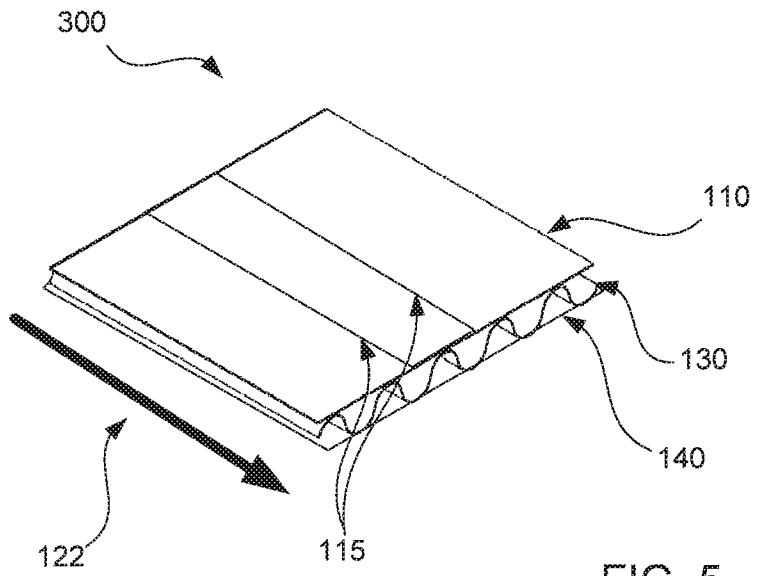

FIG. 5

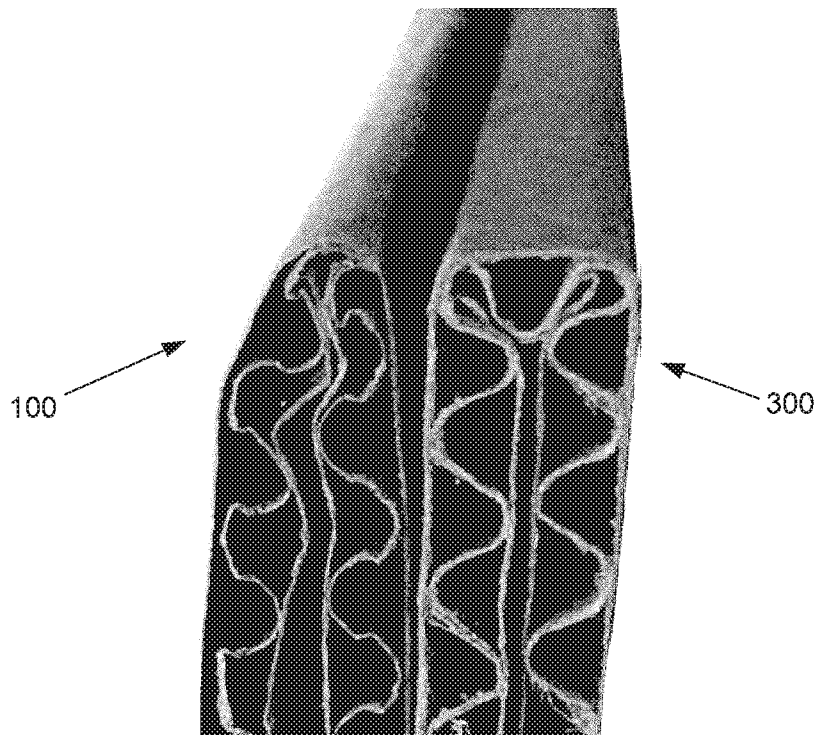

FIG. 7

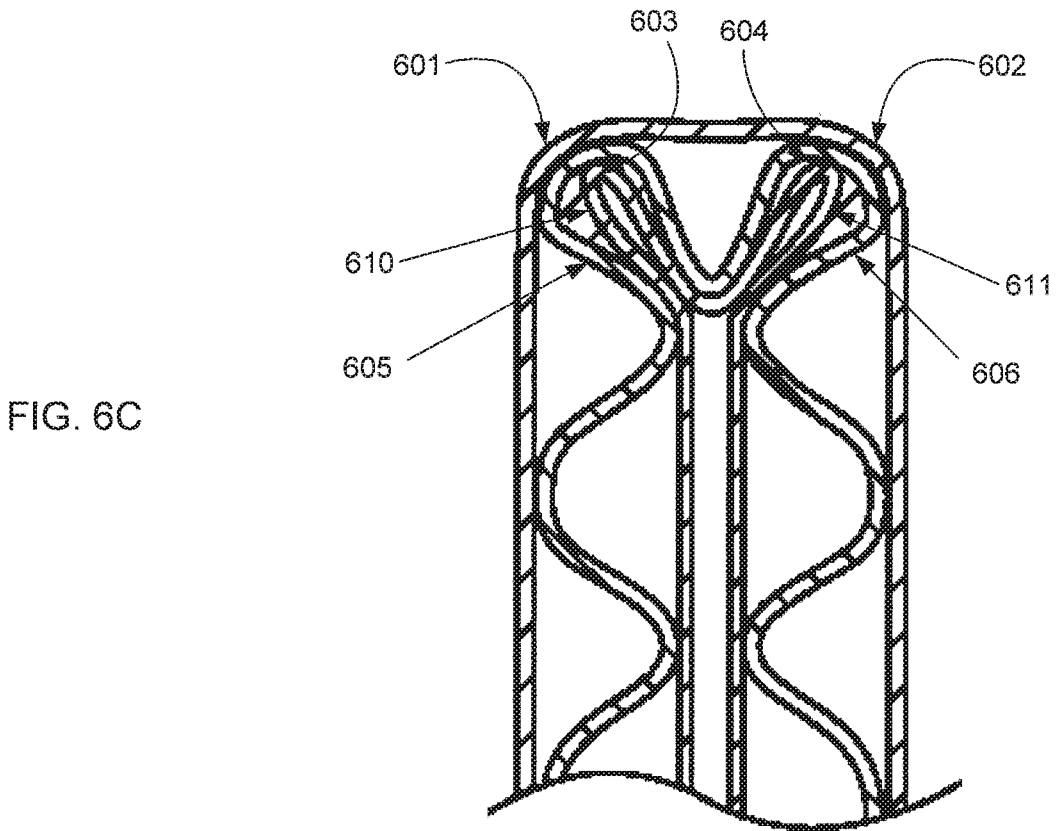
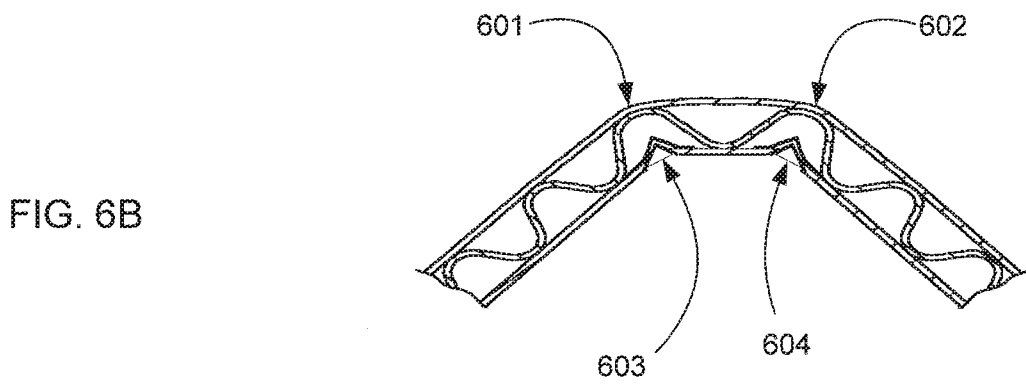
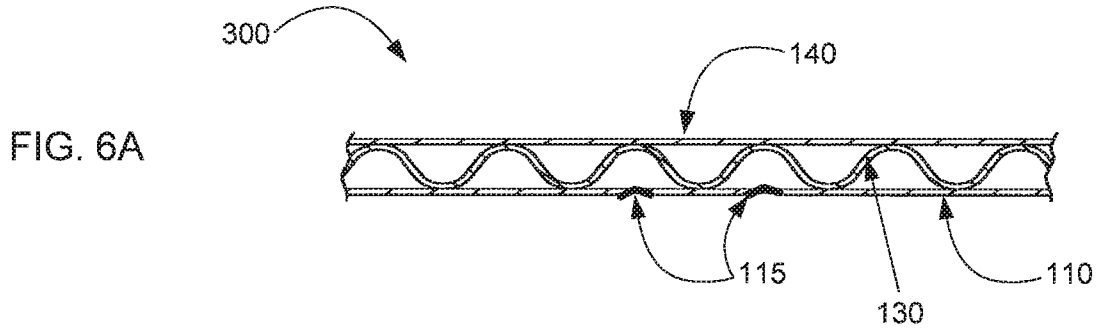

FIG. 8A

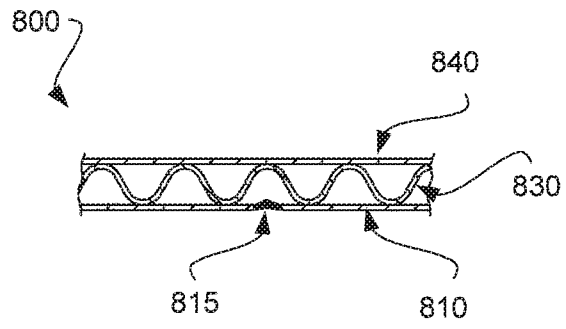
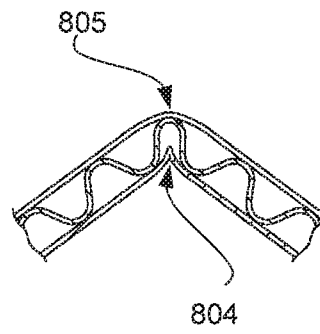

FIG. 8B



7/7

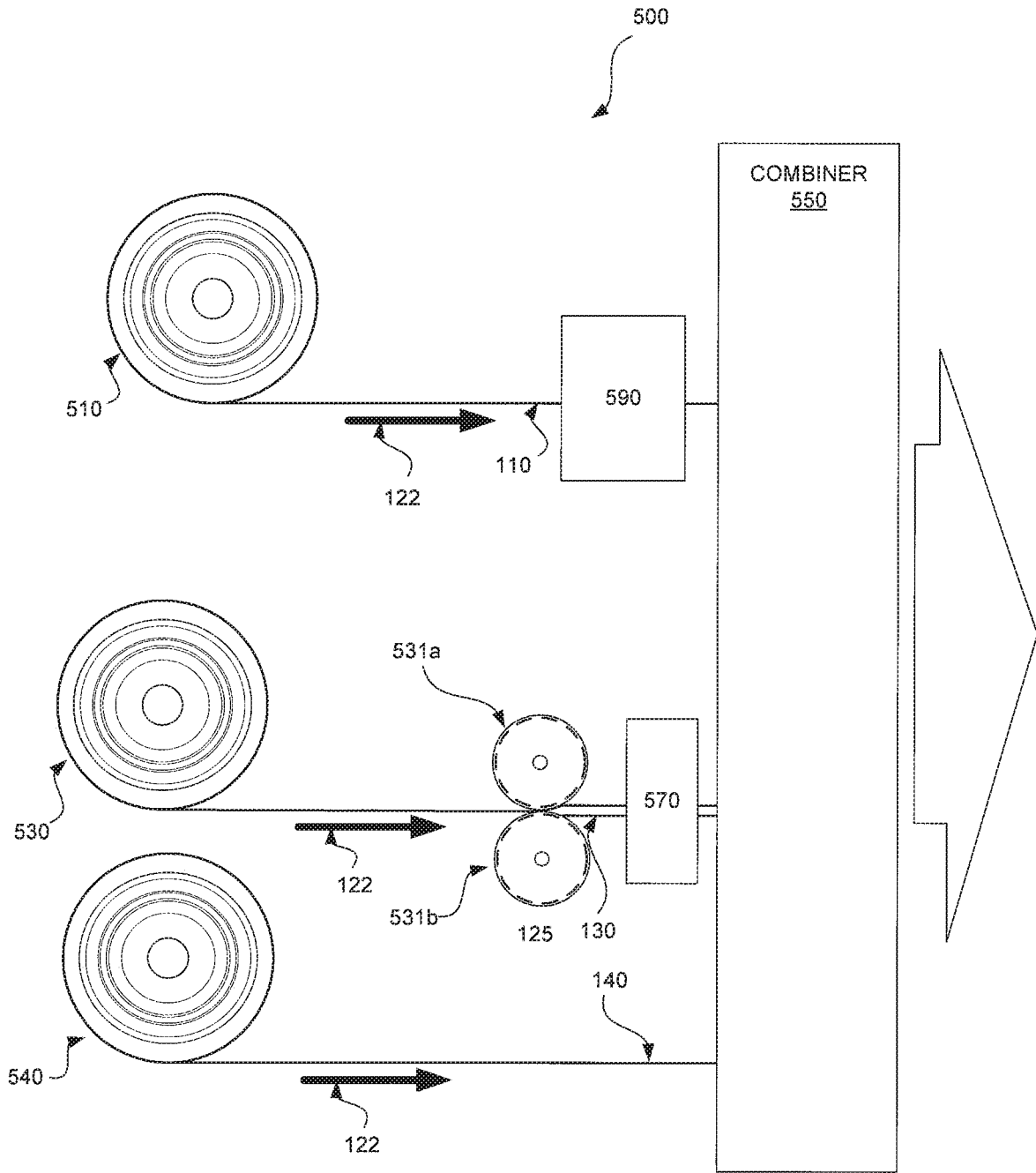

FIG. 9

INTERNATIONAL SEARCH REPORT

International application No.
PCT/US2017/027614

A. CLASSIFICATION OF SUBJECT MATTER
 IPC(8) - B31F 1/00; B31B 1/00; B31B 1/25; B31F 1/08; B32B 29/08; B65D 5/42; B65H 45/12 (2017.01)
 CPC - B31F 1/0012; B31B 2201/25; B31B 2201/252; B31F 1/08; B31F 1/28; B32B 29/08; B65D 5/4266 (2017.05)

According to International Patent Classification (IPC) or to both national classification and IPC

B. FIELDS SEARCHED

Minimum documentation searched (classification system followed by classification symbols)
 See Search History document

Documentation searched other than minimum documentation to the extent that such documents are included in the fields searched
 USPC - 229/930; 229/939; 493/59; 493/162 (keyword delimited)

Electronic data base consulted during the international search (name of data base and, where practicable, search terms used)
 See Search History document

C. DOCUMENTS CONSIDERED TO BE RELEVANT

Category*	Citation of document, with indication, where appropriate, of the relevant passages	Relevant to claim No.
X ---	US 3,039,372 A (LA BOMBARD) 19 June 1962 (19.06.1962) entire document	1, 2, 4, 8 ---
Y		3, 5-7, 9-20
Y	US 2004/0224828 A1 (NELLES) 11 November 2004 (11.11.2004) entire document	3, 5, 10, 19
Y	GB 977,069 A (PHILIPS ELECTRONIC AND ASSOCIATED INDUSTRIES LIMITED) 02 December 1964 (02.12.1964) entire document	6, 7, 12, 13
Y	US 3,529,516 A (DORSEY et al) 22 September 1970 (22.09.1970) entire document	9-20
A	WO 2014/146036 A1 (CORRUGATED SYNERGIES INTERNATIONAL, LLC et al) 18 September 2014 (18.09.2014) entire document	1-20
A	US 5,690,601 A (CUMMINGS et al) 25 November 1997 (25.11.1997) entire document	1-20

Further documents are listed in the continuation of Box C. See patent family annex.

* Special categories of cited documents:

"A" document defining the general state of the art which is not considered to be of particular relevance	"T" later document published after the international filing date or priority date and not in conflict with the application but cited to understand the principle or theory underlying the invention
"E" earlier application or patent but published on or after the international filing date	"X" document of particular relevance; the claimed invention cannot be considered novel or cannot be considered to involve an inventive step when the document is taken alone
"L" document which may throw doubts on priority claim(s) or which is cited to establish the publication date of another citation or other special reason (as specified)	"Y" document of particular relevance; the claimed invention cannot be considered to involve an inventive step when the document is combined with one or more other such documents, such combination being obvious to a person skilled in the art
"O" document referring to an oral disclosure, use, exhibition or other means	"&" document member of the same patent family
"P" document published prior to the international filing date but later than the priority date claimed	

Date of the actual completion of the international search 09 June 2017	Date of mailing of the international search report 29 JUN 2017
---	--

Name and mailing address of the ISA/US Mail Stop PCT, Attn: ISA/US, Commissioner for Patents P.O. Box 1450, Alexandria, VA 22313-1450 Facsimile No. 571-273-8300	Authorized officer Blaine R. Copenheaver PCT Helpdesk: 571-272-4300 PCT OSP: 571-272-7774
---	--