

H. RASMUSSEN.

Ventilating Apparatus for Cooking-Stoves.

No. 130,744.

Patented Aug. 20, 1872.

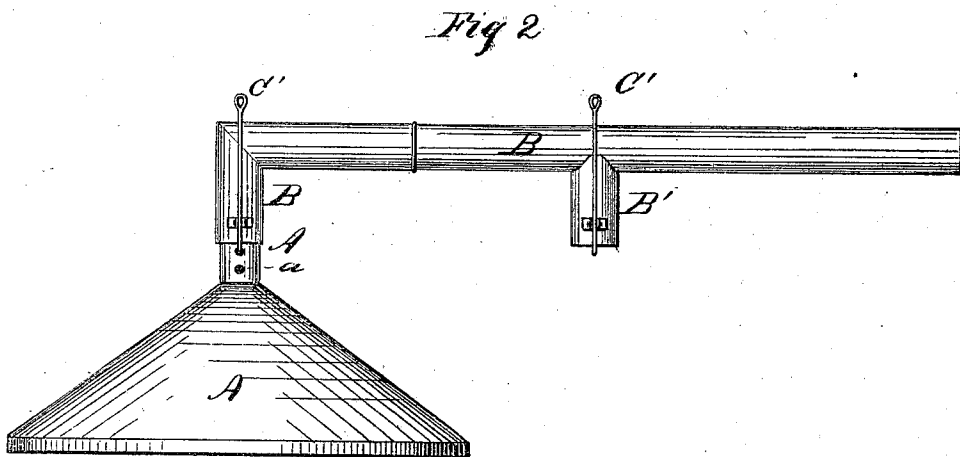
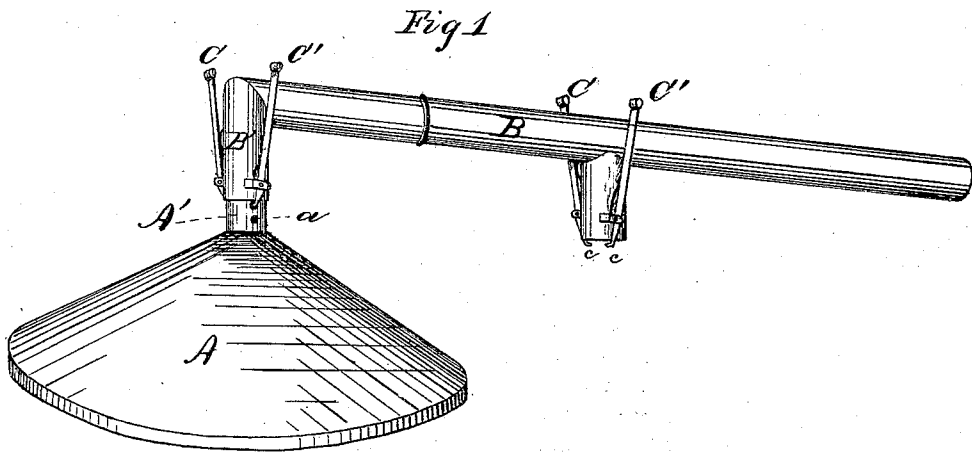

Witnesses  
W. B. Ford  
A. Ruppert.

H. Rasmussen  
Inventor:  
C. E. J. Kils  
att'y

H. RASMUSSEN.

Ventilating Apparatus for Cooking-Stoves.

No. 130,744.

Patented Aug. 20, 1872.

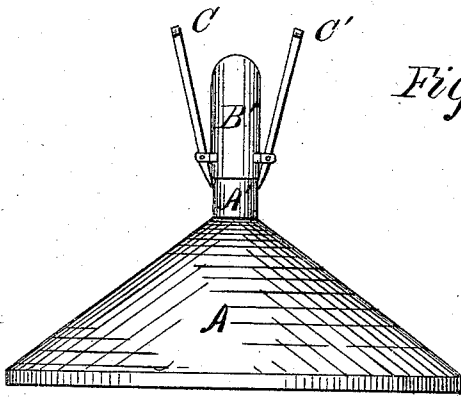

Fig 3

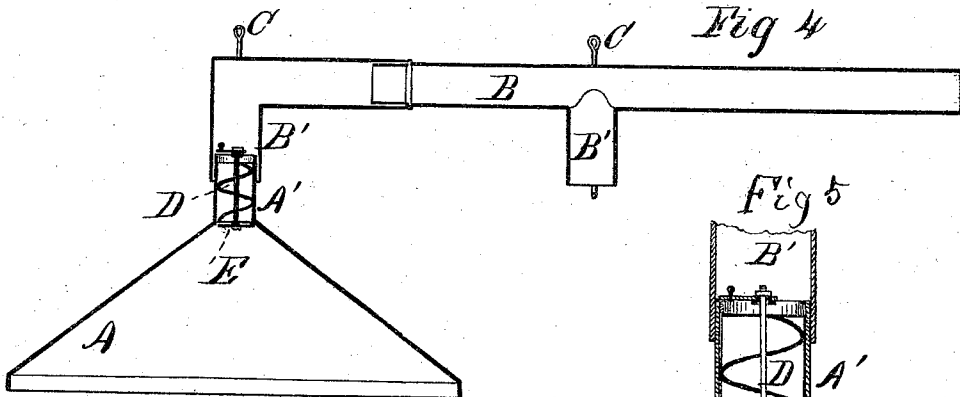

Fig 4

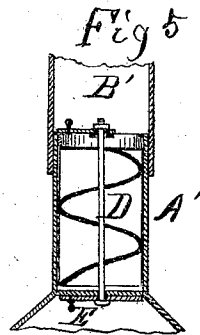

Fig 5



Fig. 7.



Fig. 8.

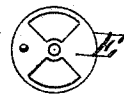

Fig. 6.

Witnesses  
 O. Bradford  
 A. Ruppert.

H. Rasmussen  
 Inventor.  
 J. S. G. Co. atty

# UNITED STATES PATENT OFFICE.

HENRIK RASMUSSEN, OF RACINE, WISCONSIN, ASSIGNOR OF ONE-HALF HIS RIGHT TO M. THORKELSON, OF SAME PLACE.

## IMPROVEMENT IN VENTILATING APPARATUS FOR COOKING-STOVES.

Specification forming part of Letters Patent No. 130,744, dated August 20, 1872.

Specification describing certain Improvements in Ventilating Apparatus for Cooking-Stoves, invented by HENRIK RASMUSSEN, residing at Racine, in the county of Racine and State of Wisconsin.

This invention relates to that class of devices which are used, in connection with cooking-stoves, to catch up the fumes and odor arising from cooking articles of food, and direct them into the smoke-pipe or chimney to be carried off with the smoke into the exterior atmosphere. My improvement consists in the employment of a hood, which is adjustably hung to a pipe, connecting it with the smoke pipe or chimney, so that it may readily be raised and lowered, and is provided with a ventilator in its throat to draw the rising fumes into the pipe, besides a register to regulate the draft through it.

Figure 1 represents my improved ventilating apparatus in perspective. Fig. 2 is a side elevation. Fig. 3 is an end elevation. Fig. 4 is a vertical longitudinal section. Figs. 5, 6, 7, and 8 are detail views.

The same letters of reference are employed in all the figures in the designation of identical parts.

The hood A is preferably made in the form of an inverted funnel, as illustrated, but may be of any other configuration adapted to the purpose it is to serve. The throat A' of the hood fits into the downwardly-projecting branch B' of the horizontal pipe B, which is either permanently or detachably connected to the smoke pipe or chimney of a cooking stove or range, and arranged to overhang the latter at a proper elevation. The pipe B, illustrated, has two branches, B', to either one of which the hood may be hung, and is made of two sections, sliding within each other. The object of constructing the pipe B as set forth is to admit of attaching a small hood, so as to cover either the front or rear stove-holes, as

occasion may require, as well as suspending a large hood covering the entire stove, in which case the outer section of the pipe will be pushed into the other section, so as to locate the outer branch B' centrally over the stove or range. The hood is suspended by spring-levers C C', which are pivoted upon opposite sides of the branches B', and the lower short arms of which are constructed with inwardly-projecting hooks c, entering corresponding holes a in the throat of the hood, a vertical series of such holes a being formed in such throat to admit of ready vertical adjustment of the hood. Each branch B' is provided with a pair of these levers, instead of which other and equivalent means may, however, be employed for the suspension of the hood, provided they admit of vertical adjustment of the latter, or, at least, of ready detachment. Suitable dampers may be arranged in the pipe B to close either of the branches B' when not in use. The hood is provided with a ventilating-wheel, D, in its throat, which, by inducing an upward draft, causes the fumes to be drawn up into the hood, to be discharged by the ventilator into the pipe B. The inner end of the throat A' is controlled by a register, E, as best seen in Figs. 5 and 6.

What I claim as my invention, and desire to secure by Letters Patent, is—

1. The combination of the hood A, sectional pipe B B', and spring-levers C C', substantially as and for the purpose specified.

2. The hood A, the throat A' of which incloses a ventilating-wheel, D, and is controlled by a register, E, substantially as and for the purpose specified.

In testimony whereof I have signed my name to this specification in the presence of two subscribing witnesses.

HENRIK RASMUSSEN.

Witnesses:

LORENZO JANES,  
DAVID G. JANES.