

(19) **DANMARK**

(10) **DK/EP 2864723 T3**



Patent- og  
Varemærkestyrelsen

(12) **Oversættelse af  
europæisk patentskrift**

- 
- (51) Int.Cl.: **F 25 D 17/04 (2006.01)**                      **A 23 B 7/148 (2006.01)**                      **A 23 L 3/3418 (2006.01)**  
**F 16 K 31/08 (2006.01)**
- (45) Oversættelsen bekendtgjort den: **2019-11-04**
- (80) Dato for Den Europæiske Patentmyndigheds bekendtgørelse om meddelelse af patentet: **2019-09-11**
- (86) Europæisk ansøgning nr.: **13722183.4**
- (86) Europæisk indleveringsdag: **2013-04-25**
- (87) Den europæiske ansøgnings publiceringsdag: **2015-04-29**
- (86) International ansøgning nr.: **US2013038104**
- (87) Internationalt publikationsnr.: **WO2014003882**
- (30) Prioritet: **2012-06-25 US 201261663868 P**
- (84) Designerede stater: **AL AT BE BG CH CY CZ DE DK EE ES FI FR GB GR HR HU IE IS IT LI LT LU LV MC MK MT NL NO PL PT RO RS SE SI SK SM TR**
- (73) Patenthaver: **Carrier Corporation, 1 Carrier Place, Farmington, CT 06034, USA**
- (72) Opfinder: **RICHARDSON, Curtis, 6350 Thompson Road, Carrier Parkway, Syracuse, NY 13206, USA**
- (74) Fuldmægtig i Danmark: **AWA Denmark A/S, Strandgade 56, 1401 København K, Danmark**
- (54) Benævnelse: **Elektromagnetisk kontraventil**
- (56) Fremdragne publikationer:  
**WO-A1-00/23350**  
**DE-A1- 3 621 332**  
**US-A- 3 921 670**  
**US-A- 4 196 751**



# DESCRIPTION

## CROSS REFERENCE TO RELATED APPLICATIONS

## BACKGROUND OF THE INVENTION

**[0001]** The invention relates generally to transport refrigeration systems and, more particularly, to an electro-magnetic check valve of a transport refrigeration system.

**[0002]** A transport refrigeration system is used to control an environment in an enclosed area, such as the insulated box on trailers, trucks, containers. The refrigeration system absorbs heat from the enclosed area and releases the heat outside of the box into the environment.

**[0003]** Perishable items that are commonly transported in such refrigeration systems respire over time, converting oxygen into carbon dioxide. If the concentration of oxygen is too low, or the concentration of carbon dioxide is too high, the cargo may be damaged. Fresh air exchanges avoid such a result by drawing fresh air into the system and forcing the carbon dioxide out an exhaust. The amount of fresh air drawn into the refrigeration system must be limited because the air may dry out the perishable items, and because power from the system must be used to cool the air.

**[0004]** US 3 921 670 A discloses an electrically controlled valve with a movable valve element which is in the form of a so-called "spider". The spider is a one piece element which includes a unitary central portion or armature and a peripheral or mounting portion. These portions are connected by arcuate spiderlike arms which act as springs between the central portion and the peripheral portion, so that the spider is yieldable in an axial direction. When a magnetic force is applied to the valve, the spider is drawn away from a first pressure port toward a second vent port.

**[0005]** WO 00/23350 A1 discloses an apparatus and methods for adjusting the atmosphere within a substantially sealed chamber containing respiring products. The chamber is provided with inlet and outlet means which each may include a plurality of valves so as to facilitate the desired air flow, and which comprise a bore, a member moveable within the bore, at least one sealing surface associated with the member, at least one aperture through which fluid may pass to pass through the valve, and a solenoid adapted to generate a magnetic field in the bore in response to the application of a direct electric current. The member is adapted to move with respect to the bore in response to said magnetic field between an open position and a closed position wherein said at least one sealing surface prevents fluid passing through each said at least one aperture.

**[0006]** DE 36 21 332 A1 discloses a microvalve with a valve chamber and with a disc-shaped

valve body which is connected via resilient elements to the rim of the valve chamber and can be moved in a controlled manner into two different positions in which it closes or exposes a valve opening at the bottom of the valve chamber. For the purpose of achieving higher actuating forces for the valve disc, the valve disc is formed as a magnet armature for an electric coil situated in the region of the valve opening.

#### **BRIEF DESCRIPTION OF THE INVENTION**

**[0007]** According to one embodiment of the invention, an electro-magnetic check valve for use in an air exchange panel of a transportation refrigeration system is provided including a valve cap positioned adjacent the air exchange panel and movable between a first position and a second position. The valve cap includes a magnetic portion and is made of an iron based steel, wherein the valve cap includes at least one sealing mechanism being connected to or integrally formed with a second surface opposite a first surface of the valve cap, wherein the sealing mechanism is a generally v-shaped peak that extends from the second surface of the valve cap. A resilient flexible member is mounted to the valve cap and is coupled to the air exchange panel. The resilient flexible member biases the valve cap into a first position. The resilient flexible member is made from a sheet metal and includes a plurality of grains such that the resilient flexible member has an increased flexibility parallel to the plurality of grains and an increased stiffness normal to the plurality of gains. An electromagnet is positioned inside the air exchange panel, opposite the valve cap. A controller is coupled to the electromagnet to selectively apply power to move the valve cap between the first position and the second position.

**[0008]** According to another embodiment of the invention, a transportation refrigeration system is provided including a container having a wall. A sensor detects a state inside the container. An air exchange panel is located with the wall of the container and includes an air intake duct. The electro-magnetic check valve of the previous paragraph is mounted to the air exchange panel.

**[0009]** According to yet another embodiment of the invention, a method for operating a transportation refrigeration system having a container configured to store cargo is provided including detecting an oxygen level within the container. Power is applied to an electromagnet if the oxygen level is greater than or equal to a threshold. The oxygen level within the container is again detected. Power is removed from the electromagnet if the oxygen level is below the threshold. The valve cap is biased into a first position by a resilient flexible member.

**[0010]** These and other advantages and features will become more apparent from the following description taken in conjunction with the drawings.

#### **BRIEF DESCRIPTION OF THE DRAWING**

**[0011]** The subject matter, which is regarded as the invention, is particularly pointed out and distinctly claimed in the claims at the conclusion of the specification. The foregoing and other features, and advantages of the invention are apparent from the following detailed description taken in conjunction with the accompanying drawings in which:

FIG. 1 is a cross-section of a portion of a transportation refrigeration system;

FIG. 2 is a perspective view of an open air exchange valve;

FIG. 3 is a perspective view of a closed air exchange valve;

FIG. 4 is a perspective view of an air exchange panel;

FIG. 5 is a perspective view of an air exchange panel; and

FIG. 6 is a cross-section of another air exchange valve, not part of the present invention.

#### **DETAILED DESCRIPTION OF THE INVENTION**

**[0012]** Referring to FIG. 1, a simplified schematic diagram of a portion of an exemplary transport refrigeration system 10 is illustrated. The system 10 includes a container 12 for storing cargo, such as perishable goods for example. At least one wall 14 of the container 12 includes an air exchange panel 20. The air exchange panel 20 includes at least one air intake duct 22, at least one air exhaust duct 24, an air exchange valve 100 and a sensor 26. The air intake duct 24 receives oxygen-rich air external to the system, such as from the atmosphere for example. The carbon dioxide-rich air within the container 12 flows through the air exhaust duct 24 and is discharged outside the container 12. In one embodiment, the sensor 26 is configured to detect the amount of oxygen in the container 12 and based on the oxygen level detected to selectively operate the air exchange valve 100. More specifically, if the sensed oxygen level is below a predetermined value, a controller 28 in communication with the sensor 26 will open the air exchange valve 100, so that oxygen-rich air will flow through the air intake duct 22 and into the container 12. It will be appreciated that alternatively, the sensor 26 may be configured to sense the amount of carbon-dioxide in the container 12.

**[0013]** The air exchange valve 100 is mounted to the air exchange panel 20 adjacent the air intake duct 22 and is movable between a closed position, in which the air flow through the air intake duct 22 is inhibited, and an open position, in which the airflow through the air intake duct 22 is allowed. The air exchange valve 100 is electrically coupled through a controller 28 to the sensor 26. During normal operation of the system, when the sensor 26 determines that the oxygen in the container 12 is at an acceptable level, the valve 100 is held in the closed position, and flow through the air intake duct 22 is prohibited or substantially inhibited. If, however, the sensor 26 determines that the oxygen level is low, the valve 100 is opened, allowing oxygen-rich air to flow through the air intake duct 22 and into the container 12.

**[0014]** Referring now to FIGS. 2 and 3, an air exchange valve 100 is illustrated. The air exchange valve 100 includes a valve cap 102 mounted to a resilient flexible member 110, the valve cap 102 being movable between an open position and a closed position. The valve cap 102 is made from an iron based steel. The valve cap 102 is sized such that when the valve cap 102 is in a closed position, the valve cap 102 inhibits air flow through the air intake ducts 22 of the air exchange panel 20. In one embodiment, a portion 112 of the resilient flexible member 110 is coupled to a first surface 104 of the valve cap 102, such as at the center of the first surface 104 for example. Alternate connections between the resilient flexible member 110 and the cap 102 are within the scope of the invention. The resilient flexible member 110 is made from a sheet metal having a grain structure such that the resilient flexible member 110 has an increased flexibility in a direction parallel to the grain and an increased stiffness in a direction normal to the grain. The resilient flexible member 110 biases the valve cap 102 into an open position. In one embodiment, when the valve cap 102 is in an open position (see FIG. 2), the resilient flexible member 110 is located within a plane and the first surface 104 of the valve cap 102 coupled to the resilient flexible member 110 is parallel to and abuts that plane. When the valve cap 102 is in a closed position, shown in FIG. 3, the portion 112 of the resilient flexible member 110 coupled to the valve cap 102 extends out of the plane in the direction of the air exchange panel 20.

**[0015]** The valve cap 102 includes at least one sealing mechanism 108 (FIG. 5) for engagement with a portion of an air exchange panel 20. The sealing mechanism 108 may be connected to or may be integrally formed with a second surface 106 (FIG. 5), opposite the first surface 104, of the valve cap 102. The sealing mechanism 108 is a generally v-shaped peak that extends from the second surface 106 of the valve cap 102 to engage a gasket on the air exchange panel 20 to seal a respective air intake duct 22. The resilient flexible member 110 includes a first flange 114 having a first hole 116 and a second flange 120 having a second hole 122. The first flange 114 and the second flange 120 are coplanar and located on opposing sides of the resilient flexible member 110. A first spacer 118 is mounted to the first flange 114 adjacent the first hole 116 and a second spacer 124 is mounted to the second flange 120 adjacent the second hole 122. The first and second spacers 118, 124 extend perpendicular to the plane of the resilient flexible member 110 in the direction of the air exchange panel 20. The spacers 118, 124 may be used to couple a portion of the resilient flexible member 110 to the air exchange panel 20 at a fixed distance.

**[0016]** FIGS. 4 and 5 are cross-sectional views of the air exchange panel 20 when the air exchange valve 100 is in an open position and a closed position. Housed within the air exchange panel 20, is an electromagnet 150. In one embodiment, the electromagnet 150 includes an iron core and a wire 152 wrapped around the iron core. The wire 152 of the electromagnet 150 is coupled to the controller 28 so that power may be selectively applied to the wire 152. At least one air intake duct 22 is disposed adjacent the electromagnet 150. The air intake duct 22 extends through the air exchange panel 20 and into the container 12. The air exchange valve 100 is mounted to an exterior surface 21 of the air exchange panel 20 using a plurality of fasteners, such as screws for example. A fastener may extend through the hole

116, 122 in the flanges 114, 120 of the resilient flexible member 110 and the adjacent spacer 118, 124 respectively into the air exchange panel 20. The spacers 118, 124 define a space between the plane of the resilient flexible member 110 and the air exchange panel 20 so that the valve cap 102 may move between an open position and a closed position.

**[0017]** During operation of the transport refrigeration system 10, the air exchange valve 100 is biased into the open position by the resilient flexible member 110, as shown in FIG. 4. When the valve cap 102 is open, air may flow through the air intake ducts 22 of the air exchange panel 20. The pressure differential between the atmosphere and the inside of the container 12 draws the air through the open air intake ducts 22 and into the container 12.

**[0018]** If the sensor 26 detects that the oxygen level inside the container 12 has reached an acceptable level, the sensor 26 generates and sends a signal to the controller 28 coupled to the electromagnet 150. The controller 28 closes the valve 100 by applying power to the wire 152. When power is applied, the electromagnet 150 generates a magnetic field that attracts the valve cap 102, such that the sealing mechanisms 108 of the valve cap 102 create a seal about the air intake duct 22. The valve 100 will remain closed as long as the controller continues to power the electromagnet 150. When the sensor 26 determines that the oxygen level in the container 12 is too low, the sensor 26 generates and sends another signal to the controller 28. The controller 28, in turn, stops supplying electricity to the wire 152 of the electromagnet 150, thereby eliminating the magnetic field that attracts the valve cap 102. Because the electromagnet 150 no longer attracts the valve cap 102, the resilient flexible member 110 is able to bias the valve cap 102 into the open position. The sealing mechanisms 108 again separate from the surface 21 of the air exchange panel 20 to allow air to flow through the air intake ducts 22 and into the container 12.

**[0019]** In an alternate example, not part of the present invention, illustrated in FIG. 6, the air exchange valve 200 pivots relative to the surface 21 the air exchange panel 20, rather than moving parallel to the air exchange panel 20 as described above. A first end 204 of the valve cap 202 may be mounted to the air exchange panel 20 with a resilient flexible member 210 and at least one fastener 220. Fixed to the first end 204, adjacent the fastener 220, is a stiffener plate 212 that securely clamps the valve cap 202 in a closed position. Mounted near the free end 206 of the valve cap 202 is a magnetic material 214, such as an iron core or permanent magnet for example. The magnetic material 214 is located opposite the electromagnet 150 of the air exchange panel, such that when the electromagnet 150 generates a magnetic field, the magnetic material 214 is attracted to the electromagnet 150. During normal operation, the valve cap 202 is biased into an open position by the flexible resilient member 210. When power is applied to the electromagnet 150, the magnetic material 214 is attracted to the magnetic field of the electromagnet 150 and the valve cap 202 is held in a closed position. When power is removed from the electromagnet 150, the magnetic force attracting the permanent magnet 214 is eliminated, and the resilient flexible member 210 biases the valve cap 202 to an open position. A stop 230 may be disposed adjacent the free end 206 of the valve cap 202 to limit the angular movement of the valve cap 202 relative to the air exchange panel 20. Though it is desirable to provide a valve 202 that is open in the event of

a power failure, it is within the scope of the invention to apply power to the electromagnet 150 to open the valve 200 rather than to close it.

**[0020]** While the invention has been described in detail in connection with only a limited number of embodiments, it should be readily understood that the invention is not limited to such disclosed embodiments. Rather, the invention can be modified to incorporate any number of variations, alterations, substitutions or equivalent arrangements not heretofore described, but which are commensurate with the scope of the invention. Additionally, while various embodiments of the invention have been described, it is to be understood that aspects of the invention may include only some of the described embodiments. Accordingly, the invention is not to be seen as limited by the foregoing description, but is only limited by the scope of the appended claims.

## **REFERENCES CITED IN THE DESCRIPTION**

This list of references cited by the applicant is for the reader's convenience only. It does not form part of the European patent document. Even though great care has been taken in compiling the references, errors or omissions cannot be excluded and the EPO disclaims all liability in this regard.

### **Patent documents cited in the description**

- [US3921670A \[0004\]](#)
- [WO0023350A1 \[0005\]](#)
- [DE3621332A1 \[0006\]](#)

Patentkrav:

5

1. Elektromagnetisk kontraventil (100) til anvendelse i et luftudvekslingspanel (20) i et transportkølesystem (10) omfattende:

10 en ventilhætte (102), der er anbragt tilstødende luftudvekslingspanelet (20) og kan bevæges mellem en første position og en anden position, hvilken ventilhætte (102) indbefatter en magnetisk del og er fremstillet af et jernbaseret stål, hvor ventilhætten indbefatter mindst én forseglingsmekanisme (108), der er forbundet til eller udformet integreret med en anden overflade modsat en første overflade af ventilhætten (102), hvor forseglingsmekanismen (108) er en generelt v-formet spids, der strækker sig fra den anden overflade af ventilhætten (102),

15 et elastisk, fleksibelt element (110), der er monteret på ventilhætten (102), hvilket elastiske, fleksible element (110) er koblet til luftudvekslingspanelet (20) for at forspænde ventilhætten (102) ind i en første position, hvor det elastiske, fleksible element (110) er fremstillet af et plademetal og indbefatter en flerhed af mønstre, således at det elastiske, fleksible element (110) har en øget fleksibilitet parallelt med flerheden af mønstre og en

20 øget stivhed sammenfaldende med flerheden af mønstre, en elektromagnet (150), der er anbragt inden i luftudvekslingspanelet (20) modsat ventilhætten (102), og

en styreenhed (28), der selektivt påfører kraft på elektromagneten (150) for at bevæge ventilhætten (102) mellem den første position og den anden position.

25

2. Elektromagnetisk kontraventil (100) ifølge krav 1, hvor ventilhætten (102) indbefatter en permanent magnet.

3. Elektromagnetisk kontraventil (100) ifølge krav 1, hvor det elastiske, fleksible element (110) er placeret inden i et plan, når ventilhætten (102) er i den første position.

30

4. Elektromagnetisk kontraventil (100) ifølge krav 1, hvor det elastiske, fleksible element (110) strækker sig i et plan i retning mod elektromagneten (150), når ventilhætten (102) er i den anden position.

35

5. Transportkølesystem (10) omfattende:

en beholder (12) med en væg (14),

en sensor (26) til at registrere en tilstand inden i beholderen (12),

et luftudvekslingspanel (20) anbragt inden i væggen (14) i beholderen (12), der

40 indbefatter en luftindtagskanal, og

en elektromagnetisk kontraventil (100) ifølge et hvilket som helst af kravene 1 til 4.

6. Transportkølesystem (10) ifølge krav 5, hvor sensoren (26) registrerer en iltmængde inden i beholderen (12).

45

7. Transportkølesystem (10) ifølge krav 6, hvor sensoren (26) registrerer en kuliltemængde inden i beholderen (12).
8. Fremgangsmåde til drift af et transportkølesystem (10) med en beholder (12), der er konfigureret til at opbevare last, omfattende:
- 5 at registrere et iltniveau inden i beholderen (12),
  - at påføre kraft på en elektromagnet (150), hvis iltniveauet er over eller lig med en tærskel,
  - 10 at registrere iltniveauet inden i beholderen (12),
  - at fjerne kraft fra elektromagneten (150), hvis iltniveauet er under tærsklen, og
  - at forspænde en ventilhætte (102) ved anvendelse af et elastisk, fleksibelt element (110), der er monteret derpå, til en første position for at tillade en strømning af iltrig luft ind i beholderen (12), idet ventilhætten (102) er anbragt tilstødende luftudvekslingspanelet (20) og kan bevæges mellem en første position og en anden position, idet ventilhætten (102) indbefatter en magnetisk del og er fremstillet af et jernbaseret stål, hvor ventilhætten indbefatter mindst én forseglingsmekanisme (108), der er forbundet til eller udformet integreret med en anden overflade modsat en første overflade af ventilhætten (102), hvor forseglingsmekanismen (108) er en generelt v-formet spids, der strækker sig fra den anden overflade af ventilhætten (102), og hvor det elastiske, fleksible element (110) er monteret på ventilhætten (102), idet det elastiske, fleksible element (110) er koblet til luftudvekslingspanelet (20) for at forspænde ventilhætten (102) ind i den første position, hvor det elastiske, fleksible element (110) er fremstillet af et plademetal og indbefatter en flerhed af mønstre, således at det elastiske, fleksible element har en øget fleksibilitet parallelt med flerheden af mønstre og en øget stivhed sammenfaldende med flerheden af mønstre.
  - 15
  - 20
  - 25
9. Fremgangsmåde ifølge krav 8, hvor iltniveauet registreres af en sensor (26) inden i beholderen (12).
10. Fremgangsmåde ifølge krav 8, hvor styreenheden (28) er koblet til både sensoren (26) og elektromagneten (150).
11. Fremgangsmåde ifølge krav 10, hvor styreenheden (28) påfører kraft på og fjerner kraft fra elektromagneten (150) som reaktion på et signal fra sensoren (26).
12. Fremgangsmåde ifølge krav 8, hvor det elastiske, fleksible element (110) er koblet til ventilhætten (102).

# DRAWINGS

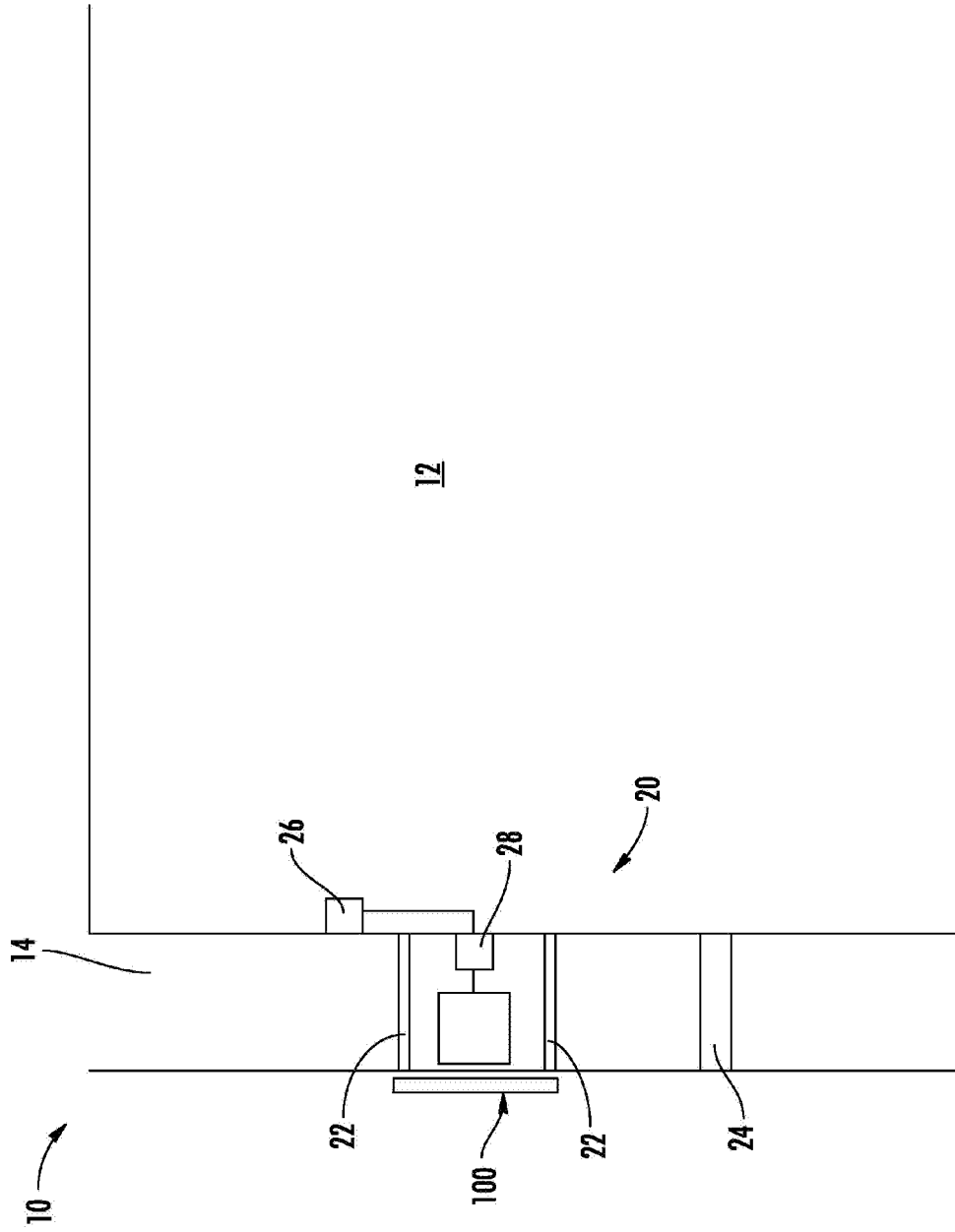

FIG. 1

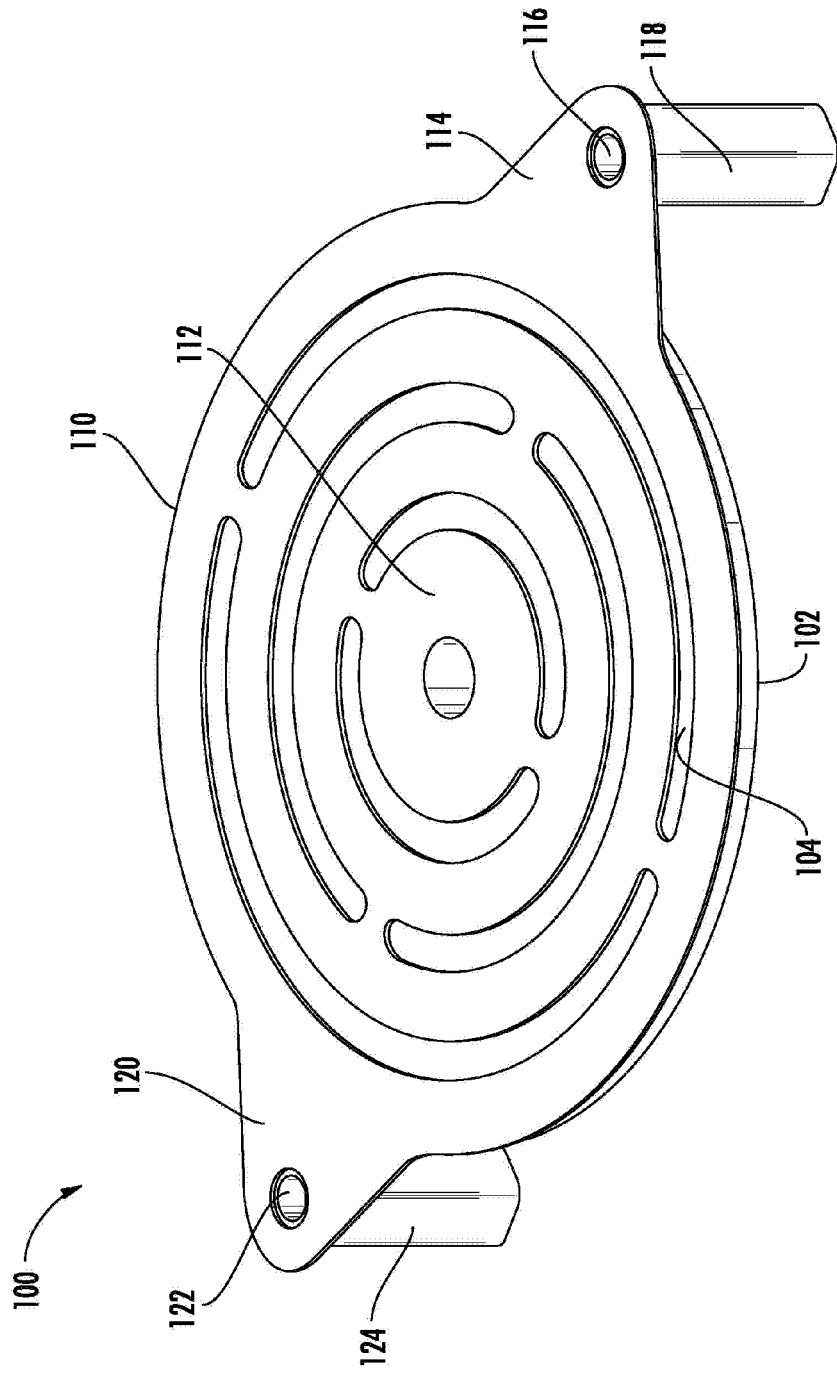

FIG. 2

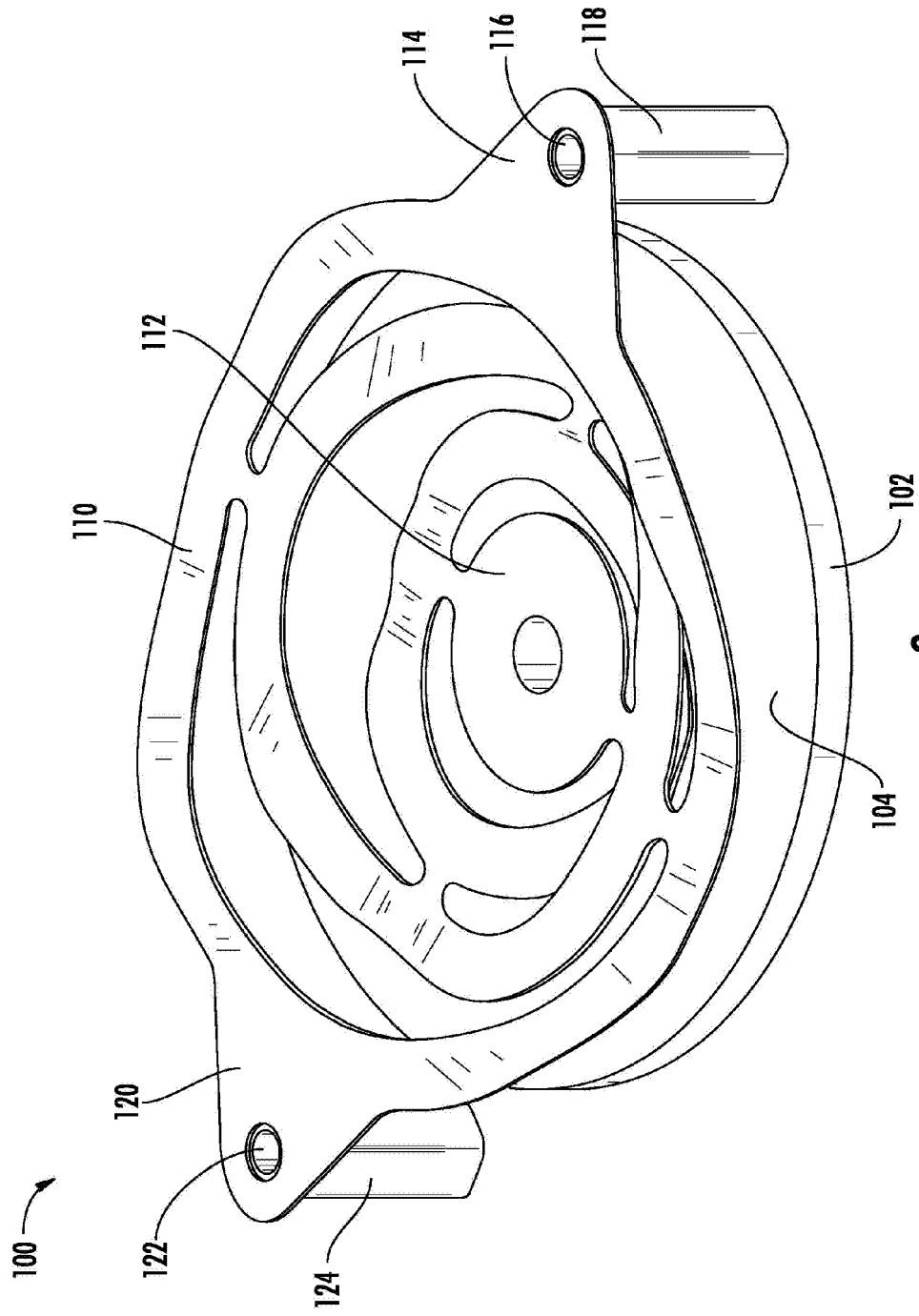
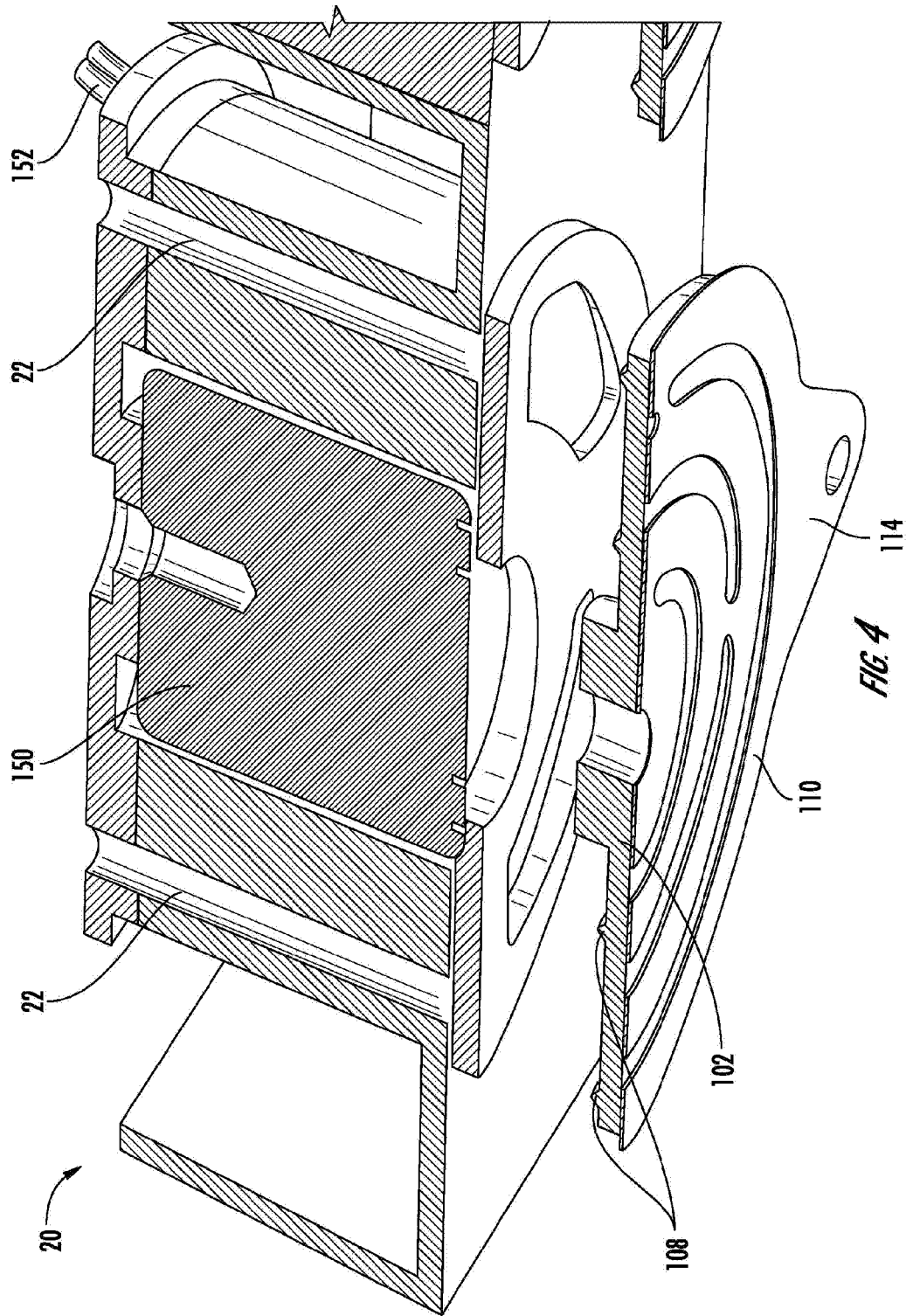

FIG. 3



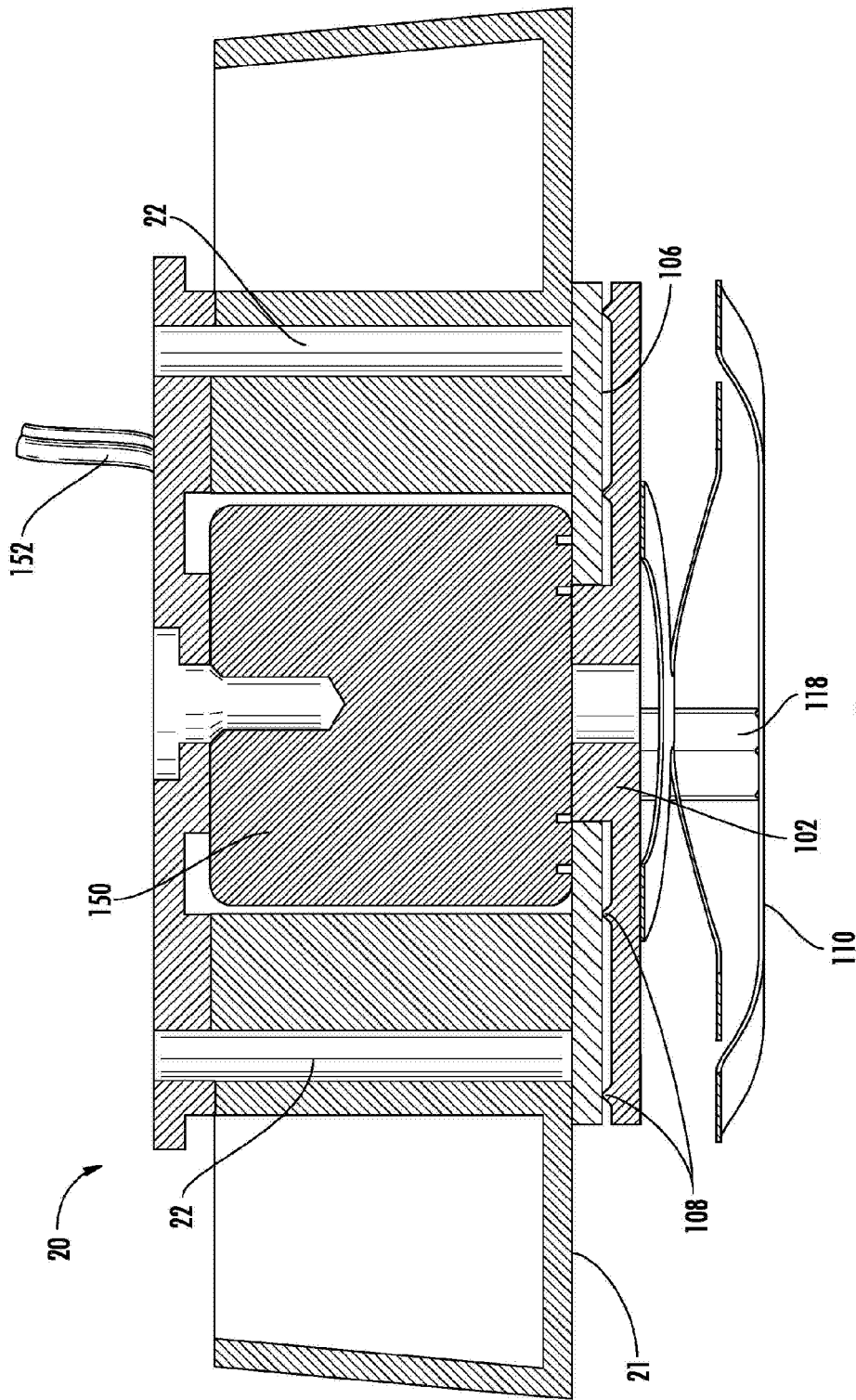

FIG. 5

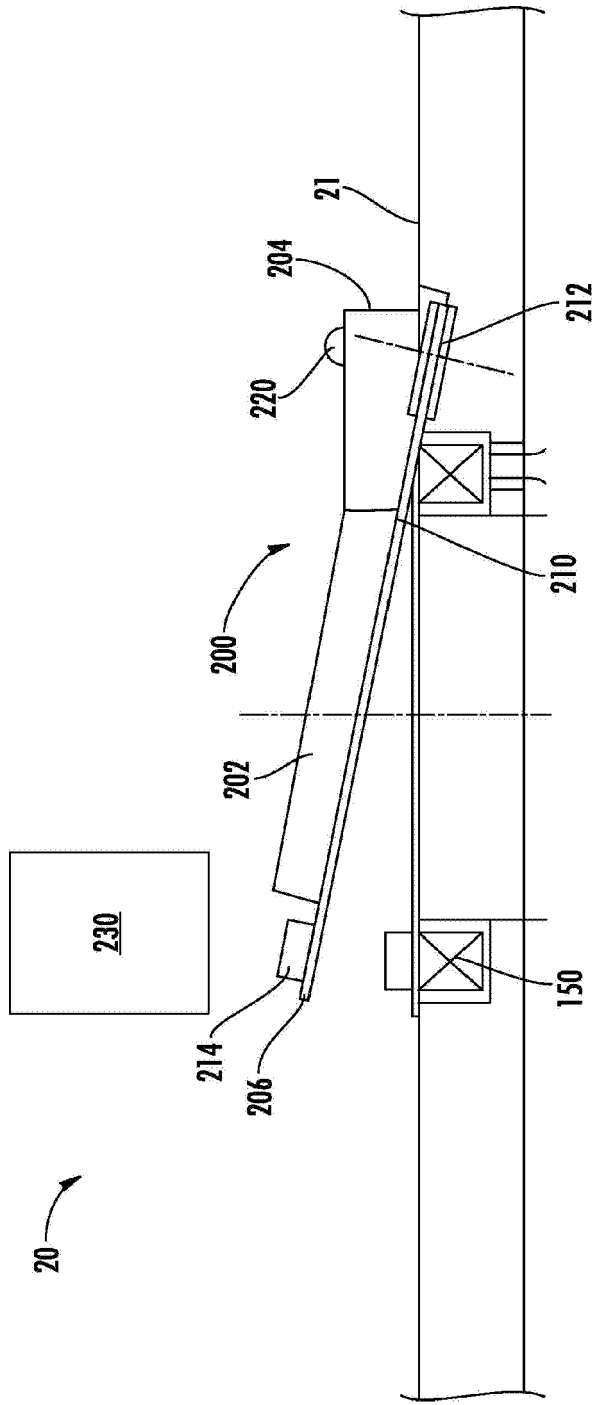

FIG. 6