

(19)
(12)

(KR)
(A)

(51) 。 Int. Cl. ⁷
E02D 3/10

(11)
(43)

2002 - 0000318
2002 01 05

(21) 10 - 2000 - 0034778
(22) 2000 06 23

(71)

175

(72)

162 303 603

1586 가 308 602

3 302 103

552 1704

(74)

:

(54)

0.3m

가

, , , ,

1

2

3

< >

1 : 2 :

3 : 4 :

5 : 6 :

7a,b,c,d,e : 8a,b :

9 : 10 :

11 : () 12 : ()

13 : 14 :

15 :

0.5 10cm

, ,

, ,

가 가

가

(Trafficability)

Mat) , (Sand

가 가

가 가

가

가, 가 10m

(14) (13)

1 (15) (1) (13)

(11) (1) (1) (11) (4) (7a) 0.3m (4)

(1) (4) (4) (9) (9) (1) (11)

(7c) (7b) (4) (4) (9) (1)

(4) (3) 30cm (5)

(5) (8a) 1 (2) (6)

(3) (5)

4) , (4) (5) (13) , (9) (1)

2 20cm (7d) (14) (9) (1) 1.0m 가 (12) 40cm (7e) , (1) 40cm (8b) (14)

3 (15) (13) (14)

(57)

1.

0.3m

가

2.

1 ,

가

3.

1 ,

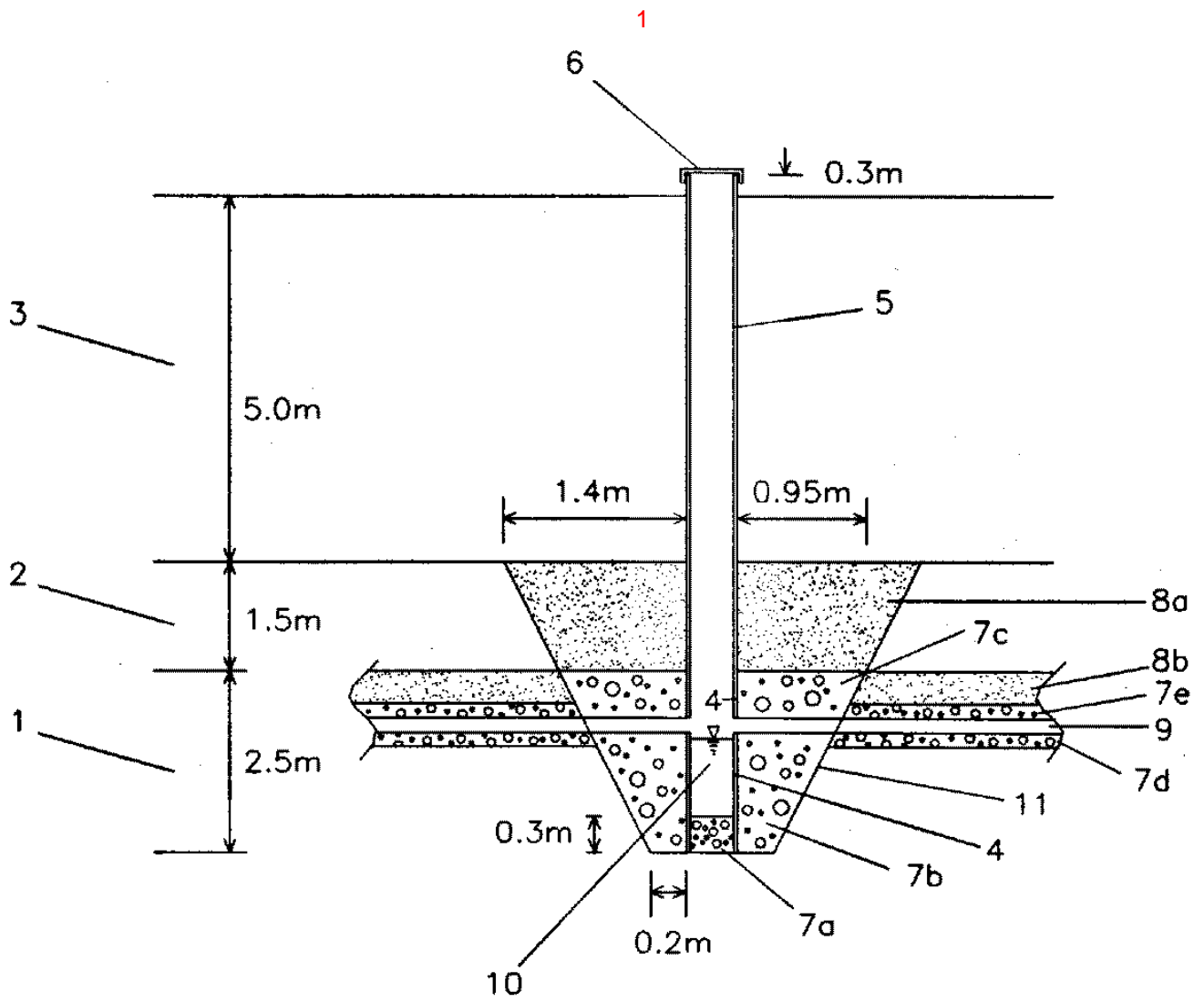

2

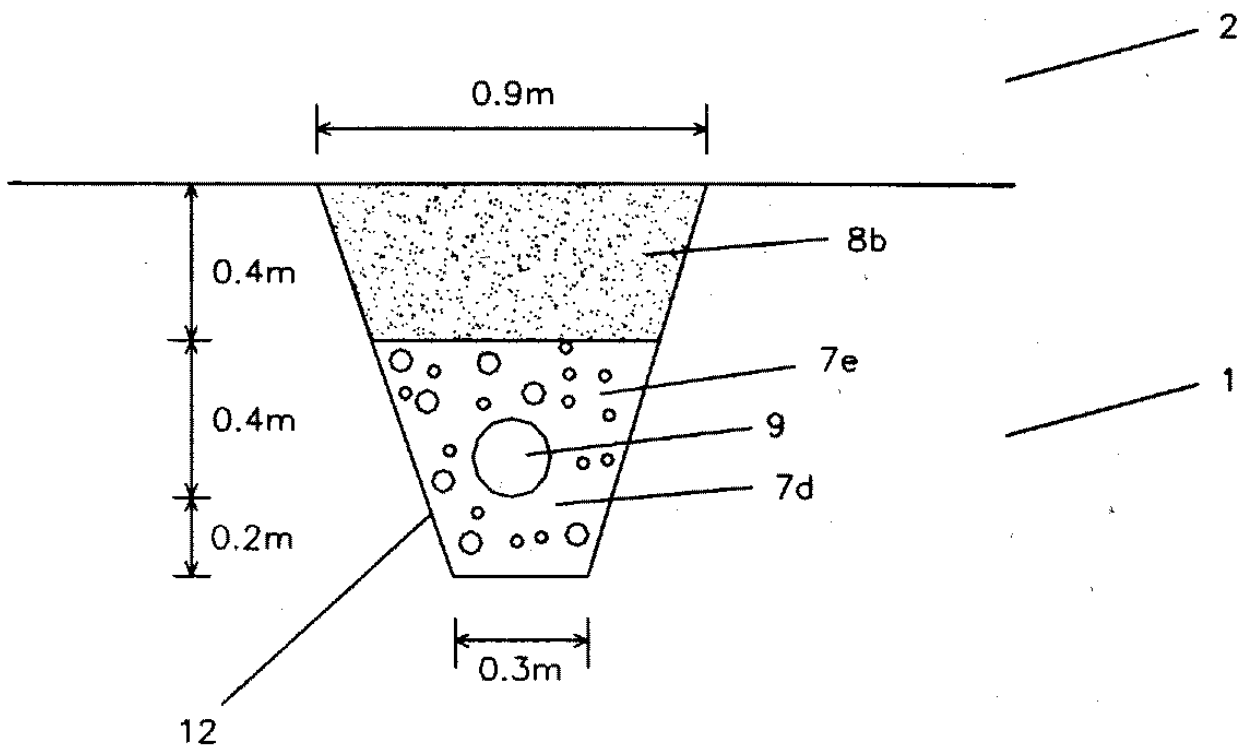

3

