

(19)



(11)

EP 2 574 253 B1

(12)

EUROPEAN PATENT SPECIFICATION

(45) Date of publication and mention of the grant of the patent:
30.08.2017 Bulletin 2017/35

(51) Int Cl.:
A45D 40/26 (2006.01)

(21) Application number: **12185652.0**

(22) Date of filing: **24.09.2012**

(54) Wiper device for cosmetic products

Abstreifvorrichtung für Kosmetikprodukte

Dispositif avec organe d'essorage pour produits cosmétiques

(84) Designated Contracting States:
AL AT BE BG CH CY CZ DE DK EE ES FI FR GB GR HR HU IE IS IT LI LT LU LV MC MK MT NL NO PL PT RO RS SE SI SK SM TR

(30) Priority: **27.09.2011 IT MI20111735**

(43) Date of publication of application:
03.04.2013 Bulletin 2013/14

(73) Proprietor: **Brivaplast S.r.l.**
20124 Milano (IT)

(72) Inventor: **Vanoncini, Stefano**
20124 Milano (IT)

(74) Representative: **Tansini, Elio Fabrizio**
Bugnion S.p.A.
Viale Lancetti 17
20158 Milano (IT)

(56) References cited:
EP-A1- 2 030 524 EP-A1- 2 374 367
EP-A2- 0 350 535 DE-A1-102008 053 905

EP 2 574 253 B1

Note: Within nine months of the publication of the mention of the grant of the European patent in the European Patent Bulletin, any person may give notice to the European Patent Office of opposition to that patent, in accordance with the Implementing Regulations. Notice of opposition shall not be deemed to have been filed until the opposition fee has been paid. (Art. 99(1) European Patent Convention).

Description

[0001] The present invention has as object a wiping device for cosmetic products. Containers intended to contain cosmetic products, preferably in liquid or semi-liquid form, such as mascara, and to allow the application thereof are known. Such containers comprise a casing, usually with cylindrical shape, which has at one end thereof an opening closed by a removable cap.

[0002] Mounted on the cap is a stem that bears an applicator, e.g. in brush form.

[0003] When the cap closes the container, the applicator is situated inside the casing, immersed in the cosmetic product. Inside the casing, close to the opening, a wiping device is also installed whose function is to eliminate, during the extraction of the stem from the casing, the excess cosmetic product present on the stem itself and on the applicator.

[0004] A wiping device of known type comprises a hollow body, counter-shaped with respect to the opening of the casing and inserted by interference in the opening itself. On the lower part of the hollow body, there is a narrowing usually defined by a frustoconical appendage made of flexible material tapered towards the bottom of the casing. When the applicator is inserted in the casing, the appendage slides against the same, offering little resistance, whereas when the applicator is extracted from the casing, the appendage interferes with the stem and with the bristles of the applicator to remove the excess cosmetic product.

[0005] In particular, in order to facilitate the assembly of the wiping device in the opening of the casing by means of automated apparatuses, and to ensure at the same time an effective wiping action on the applicator, the document EP 1771099 on behalf of the same Applicant proposes a wiper comprising a primary body with tubular conformation made of relatively rigid thermoplastic material; on one terminal edge of such body, a wiping lip with annular conformation is installed, made of softer material. Such wiping device can be made by an over-moulding process, in which a second material is injected in a moulding cavity in order to form the wiping lip directly joined to the main body previously formed by injection of a first material.

[0006] An annular gasket is made on a terminal edge of the main body opposite the wiping lip, together with the formation of the latter by injection of the second material.

[0007] An auxiliary tubular body can be arranged to completely cover the inner surface of the primary body, connecting the wiping lip and the sealing gasket together, so as to allow the flow from a single point of injection of the second material adapted to obtain the wiping lip, the gasket and the same auxiliary tubular body.

[0008] A further wiping device example, made of two parts of respectively different material, coupled by means of an over-moulding process, is illustrated in the document US 2002-195117. In this embodiment, the wiping

lip projects inside a tubular extension made of elastomer material, applied in the continuation of a primary tubular body made of rigid material. Additional examples of known wiping lips are derivable from DE 10 2008 035 905 and EP 350 535.

[0009] Nevertheless, the Applicant has found that the known implementable solutions can be improved in terms of structural reliability, assembly simplicity and production costs.

[0010] For such purpose, it was observed that the reduced size of the area available for obtaining the attachment between the two different materials at the terminal edge of the primary body tends to negatively affect the effectiveness of the anchoring between the two parts, and hence it also negatively affects the structural integrity of the wiping device following use.

[0011] Even the use of particular technical solutions, such as the selection of particular profiles in the attachment interface between the two materials close to the terminal edge of the primary body and/or the increase of the thicknesses of the primary body and the wiping lip for increasing the surface extension of the attachment interface, leads to a significant increase of costs brought by the structural complications and consequent complications in the production processes, without however offering satisfactory results.

[0012] The object of the present invention is therefore that of overcoming the limits of the prior art by providing a wiping device according to claim 1 with increased robustness and reliability. Further object of the invention is to obtain a wiping device that allows simplifying the manufacturing processes for its production and/or its assembly with a container.

[0013] For such purpose, in accordance with the present invention, it is inferred that in order to considerably increase the reliability of the anchoring of the wiping lip, it is critical to prevent separation of the lip itself at its radially external perimeter edge.

[0014] In particular, a wiping device for cosmetic products forms the object of the present invention, as defined in claim 1 and/or in one or more of the subsequent claims.

[0015] The Applicant has observed that the main cause of undesired separations is normally determined by the stresses induced during extraction of the applicator from the container. Indeed, the mechanical interference of the applicator causes a bending of the wiping lip towards the geometric axis of the passage opening. In other words, the wiping lip is bent, rotating approximately around its radially more internal attachment zone, with consequent tendency to separate its perimetricaly external edge from the primary body. The retention of the radially external edge exerted by the additional-anchoring means therefore prevents triggering breakage in the attachment interface between the holding lip and the primary body.

[0016] The effects of the invention are also extended to a container for cosmetic products, equipped with such wiping device.

[0017] Further characteristics and advantages will be

clearer from the detailed description of a preferred but not exclusive embodiment of a wiping device in accordance with the present invention. Such description is set forth hereinbelow with reference to the drawing set, provided as a mere example and hence non-limiting, in which:

- Figure 1 is a partial, sectional view of a container for cosmetic products provided with a wiping device in accordance with the present invention;
- Figure 2 shows an enlarged lateral view of the wiping device of figure 1;
- Figure 3 is a bottom view of the wiping device of figure 2;
- Figure 4 shows the wiping device sectioned along the trace IV-IV of figure 3;
- Figure 5 shows the wiping device sectioned along the trace V-V of figure 3.

[0018] With reference to the mentioned figures, with 1 a container for cosmetic products, preferably for mascara, is indicated in its entirety according to the present invention.

[0019] The container 1 comprises a casing 2, represented only in part in figure 1, intended to contain a cosmetic product, for example mascara.

[0020] The casing 2 has elongated form, preferably but not exclusively cylindrical with circular section, and it is equipped with an opening 3 through which the product content is accessed. A cap 4 is removably mounted on the casing 2, in order to close the opening 3.

[0021] According to what is represented in the enclosed figures, the opening 3 is preferably delimited by a neck 5 which is extended coaxial to a longitudinal axis "X" of the casing 2. The neck 5 is threaded and the cap 4 has a cup-like shape, with an internal thread couplable by screwing to the neck 5. A finishing element 4a can be associated with the cap 4.

[0022] The container 1 further comprises an applicator 6 integral with the cap 4.

[0023] The applicator 6, of per se known type and therefore illustrated schematically and not described in detail, can comprise a brush 6a mounted at a first end of a stem 7, whose second end is fixed to the cap 4.

[0024] The stem 7 is extended along the longitudinal axis "X" of the casing 2 and, according to what is illustrated in figure 1, it is fixed to one base 8 of the cup-like cap 4. When the cap 4 is closed on the casing 2, the applicator 6 is situated inside the casing 2 and immersed in the cosmetic product.

[0025] The container 1 further comprises a wiping device 9 which is mounted in the casing 2, preferably by interference, during assembly. The wiping device 9 is intended to enter into contact with the stem 7 and with the brush 6a, at least during the extraction of the applicator 6 from the casing 2, in order to remove the excess cosmetic product present on the same.

[0026] With particular reference to figures 2 to 5, the

wiping device 9 comprises a primary body 10 with tubular conformation having an outer side wall 11 and an inner side wall 12 preferably with substantially cylindrical conformation. The primary body 10, which for example can be made of high density polyethylene or another thermoplastic polymer, is longitudinally delimited between an upper terminal surface 13 and a lower terminal surface 14, and it is adapted to being engaged in the opening 3 of the casing 2, for example by forced insertion. For such purpose, the primary body 10 can have at least one circumferential ribbing 15 extending on its outer side wall 11, for being snap-engaged in a corresponding groove arranged in the opening 3 of the casing 2.

[0027] The wiping device 1 further comprises a wiping lip 16 extending in the continuation of the primary body 10 for defining therewith a passage extending along a geometric axis coinciding for example with the longitudinal axis X, through which the applicator 6 is insertable.

[0028] The wiping lip 16 preferably has an annular, substantially frustoconical conformation, delimited between an outer side surface 17 and an inner side surface 18 respectively extending continuously with the outer side wall 11 and the inner side wall 12 of the primary body 10.

[0029] The wiping lip 16, which for example can be made of thermoplastic elastomer softer than the material forming the primary body 10, is joined to the primary body 10 itself at an attachment interface 19 extending from the inner side surface 18 up to the outer side surface 17, at the lower terminal surface 14.

[0030] The attachment interface 19 can be extended along a plane perpendicular to the geometric axis "X" or, as in the illustrated embodiment, according to a jagged line progression, such that the wiping lip 16 has a perimeter relief 20 continuous with the outer side surface 17.

[0031] On the opposite side with respect to the attachment interface, the wiping lip 16 defines a calibrated opening 21 operating in sliding contact relation against the stem 7 and the brush 6a of the applicator 6.

[0032] The wiping lip 16 is preferably joined to the primary body 10 by molecular bonds at the attachment interface 19. Such molecular bonds are obtainable following an over-moulding process, wherein the elastomer forming the wiping lip 16 is injected in a moulding cavity containing the primary body 10, previously formed by injection of the thermoplastic polymer.

[0033] In accordance with the present invention, additional-anchoring means 22 are also provided to inhibit separation of the wiping lip 16 from the primary body 10 at least when the wiping lip 16 itself, in particular due to the stresses induced during the extraction movement of the applicator 6, is deformed towards the geometric axis "X".

[0034] The additional-anchoring means 22 are indeed preferably configured for countering the separation of the wiping lip 16 from the primary body 10 at a radially external edge of the attachment interface 19, in the illustrated embodiment at the abovementioned perimeter re-

lief 20.

[0035] For such purpose, the additional-anchoring means 22 comprise a connecting structure 23 extending along the external wall of the primary body 10, between the wiping lip 16 and a holding element 24 coupled to the primary body 10, at a position axially spaced apart from the wiping lip itself.

[0036] Such holding element 24 preferably has annular conformation and it is joined to the upper terminal surface 13 of the primary body 10, opposite to the wiping lip 16. In this case, the holding element 24 is adapted to be advantageously employed as a gasket, interposing itself between the end of the neck 5 and the cap 4 fastened by screwing on the mouth 3 of the casing 2, so as to hermetically isolate the internal of the container 1 from the external environment.

[0037] As an alternative, the holding element 24 can be exclusively arranged to cooperate with the connecting structure 23 in order to carry out a mechanical holding function.

[0038] The connecting structure 23 comprises tie-rod elements 25 extending parallel to the geometric axis "X" and having each a first end connected to the wiping lip 16 and a second end connected to said holding element 24. In the illustrated embodiment, two of said tie-rod elements 25 are provided, embedded in respective grooves arranged in diametrically opposite positions in the primary body 10, and facing the outer side wall 11 of the latter.

[0039] In a preferred embodiment, the connecting structure 23 further comprises an auxiliary holding element 26 connected to the tie-rod elements 25 and extending perimetrically relative to the primary body 10, in an intermediate position between the wiping lip 16 and the holding element 24.

[0040] The wiping lip 16, the connecting structure 23 and the holding element 24, along with the auxiliary holding element 26, are of one piece construction, preferably made by the injection over-moulding process described above with reference to the single wiping lip 16.

[0041] It is thus possible to obtain the entire connecting structure 23 and the holding elements 24, 26 at the same time as the obtainment of the wiping lip 16, without requiring additional operations.

[0042] An effective anchorage of the entire connecting structure and the holding elements 24, 26 can also be obtained, due to the molecular bonds with the primary body 10 obtainable by means of the over-moulding process.

[0043] The connecting structure 23 is thus adapted to effectively retain the wiping lip 16, preventing possible separations thereof from the primary body 10 even were the applicator 6 to be roughly extracted from the casing 2, with little care. The present invention therefore allows obtaining the wiping device 9 with limited costs, also due to the possibility of making the same in two parts by means of an over-moulding process.

[0044] The stable anchoring of the wiping lip 16 also

allows limiting, if necessary, the thickness of the primary body 10 and the wiping lip 16 itself, without the consequent reduction of the surface extension of the attachment interface 19 overly disrupting the stability of the anchoring. Such thickness reduction can be advantageous both in economical terms, e.g. by virtue of the reduced quantity of employed material, and in relation to facilitating the forced insertion of the wiping lip 16 during assembly with the container.

[0045] The improved anchoring of the wiping lip 16 also allows reducing the size of the calibrated hole 21 defined by the same for the purpose of the passage of the applicator 6. In particular, the size of the calibrated opening 21 can be significantly less than that of the stem of the applicator 6, so as to obtain a forced coupling between the same over elastic deformation of the wiping lip 16. A perfect removal of the excess product is thus ensured, without the greater stresses induced during insertion and extraction involving risks for the structural integrity of the wiping device.

[0046] At least one vent hole 27 can be radially formed through the primary body 10, to allow the inflow and outflow of air in/from the casing 2 simultaneously with the actions of introduction and extraction of the applicator 6 through the wiping device 9.

Claims

1. A wiping device for cosmetic products, comprising:

- a primary tubular body (10) having an outer side wall (11) and an inner side wall (12), longitudinally delimited between an upper terminal surface (13) and a lower terminal surface (14), and susceptible of engagement in the mouth (3) of a container for cosmetic products (1);

- a wiping lip (16) extending in the continuation of the primary body (10) for defining therewith, a passage extending along a geometric axis (X); wherein the wiping lip (16) is joined to the primary body (10) at an attachment interface (19) extending from an inner side surface (18) to an outer side surface (17) of the wiping lip (16), at the lower terminal surface (14),

- additional-anchoring means (22), to inhibit separation of the wiping lip (16) from the primary body (10) at least when the wiping lip (16) is deformed towards said geometric axis (X), **characterised in that** said additional-anchoring means (22) comprises a connecting structure (23) extending along the outer side wall (11) of the primary body (10), between the wiping lip (16) and a holding element (24) coupled to the primary body (10) at a position axially spaced apart from the wiping lip (16), wherein said wiping lip (16), connecting structure (23) and holding element (24) are of one piece construction,

wherein the connecting structure (23) comprises tie-rod elements (25) extending parallel to said geometric axis (X) and having each a first end connected to the wiping lip (16) and a second end connected to said holding element (24).

2. A device as claimed in claim 1, wherein at least the wiping lip (16) which preferably has a frustoconical conformation, is made of a softer material than the material forming the primary body (10).
3. A device as claimed in one or more of the preceding claims, wherein the wiping lip (16) is joined to the primary body (10) by molecular bonds at the attachment interface (19).
4. A device as claimed in one or more of claims 1 to 3, wherein the wiping lip (16), connecting structure (23) and holding element (24) are of one piece construction, made by injection over-moulding.
5. A device as claimed in one or more of the preceding claims, wherein said holding element (24) has an annular conformation and is joined to an end of the primary body (10) opposite to the wiping lip (16).
6. A device as claimed in one or more of the preceding claims, wherein the connecting structure (23) further comprises an auxiliary holding element (26) connected to said tie-rod elements (25) and extending perimetrically relative to the primary body (10) in an intermediate position between the wiping lip (16) and the holding element (24).
7. A device as claimed in one or more of the preceding claims, wherein at least one vent hole (27) is radially formed through the primary body (10).

Patentansprüche

1. Abstreifvorrichtung für Kosmetikprodukte, umfassend:
 - einen rohrförmigen Hauptkörper (10), aufweisend eine äußere Seitenwand (11) und eine innere Seitenwand (12), längsseitig begrenzt zwischen einer oberen Abschlussoberfläche (13) und einer unteren Abschlussoberfläche (14) und unterliegend dem Eingriff in die Öffnung (3) eines Behälters für Kosmetikprodukte (1) ;
 - eine Abstreiflippe (16), sich erstreckend in Fortsetzung des Hauptkörpers (10), um damit einen Durchgang zu definieren, der sich entlang einer geometrischen Achse (X) erstreckt, wobei die Abstreiflippe (16) mit dem Hauptkörper (10) an einer Anschlussfläche (19) zusammengefügt ist, die sich von einer inneren seitlichen Ober-

fläche (18) zu einer äußeren seitlichen Oberfläche (17) der Abstreiflippe (16) an der unteren Abschlussoberfläche (14) erstreckt;
 - zusätzliche Verankerungsmittel (22), um die Trennung der Abstreiflippe (16) vom Hauptkörper (10) zumindest dann, wenn die Abstreiflippe (16) zur geometrischen Achse (X) hinführend verformt wird, zu hemmen, **dadurch gekennzeichnet, dass** die zusätzlichen Verankerungsmittel (22) eine Verbindungsstruktur (23) umfassen, die sich entlang der äußeren Seitenwand (11) des Hauptkörpers (10) zwischen der Abstreiflippe (16) und einem Halteelement (24) erstreckt, gekuppelt mit dem Hauptelement (10) an einer Position, die axial von der Abstreiflippe (16) beabstandet ist, wobei die Abstreiflippe (16), die Verbindungsstruktur (23) und das Halteelement (24) in einem Stück gefertigt sind, wobei die Verbindungsstruktur (23) Zugankerelemente (25) umfasst, sich erstreckend parallel zur geometrischen Achse (X) und aufweisend ein erstes Ende, das mit der Abstreiflippe (16) verbunden ist, und ein zweites Ende, das mit dem Halteelement (24) verbunden ist.

2. Vorrichtung nach Anspruch 1, wobei mindestens die Abstreiflippe (16), die vorzugsweise eine stumpfkegelförmige Beschaffenheit aufweist, aus einem weichen Material besteht als das Material, das den Hauptkörper (10) bildet.
3. Vorrichtung nach einem oder mehreren der vorhergehenden Ansprüche, wobei die Abstreiflippe (16) mit dem Hauptkörper (10) zur Molekularbindungen an der Anschlussfläche (19) zusammengefügt ist.
4. Vorrichtung nach einem oder mehreren der Ansprüche 1 bis 3, wobei die Abstreiflippe (16), die Verbindungsstruktur (23) und das Halteelement (24) aus einem Stück durch Umgießen gefertigt sind.
5. Vorrichtung nach einem oder mehreren der vorhergehenden Ansprüche, wobei das Halteelement (24) eine ringförmige Beschaffenheit aufweist und mit einem Ende des Hauptkörpers (10), das gegenständig zur Abstreiflippe (16) angeordnet ist, zusammengefügt ist.
6. Vorrichtung nach einem oder mehreren der vorhergehenden Ansprüche, wobei die Verbindungsstruktur (23) zudem ein Hilfshalteelement (26) umfasst, das mit den Zugankerelementen (25) verbunden ist und sich umfangsseitig relativ zum Hauptkörper (10) an einer Zwischenposition zwischen der Abstreiflippe (16) und dem Halteelement (24) erstreckt.
7. Vorrichtung nach einem oder mehreren der vorhergehenden Ansprüche, wobei mindestens eine Ent-

lüftungsöffnung (27) radial durch den Hauptkörper (10) ausgebildet ist.

Revendications

1. Dispositif avec organe d'essorage pour produits cosmétiques, comprenant :

- un corps tubulaire principal (10), ayant une paroi latérale extérieure (11) et une paroi latérale intérieure (12), délimité longitudinalement entre une surface terminale supérieure (13) et une surface terminale inférieure (14), et susceptible de s'engager dans l'embouchure (3) d'un récipient pour produits cosmétiques (1) ;

- une lèvres d'essorage (16), s'étendant dans le prolongement du corps principal (10), pour former avec celui-ci un passage s'étendant le long d'un axe géométrique (X) ; dans lequel la lèvres d'essorage (16) est reliée au corps principal (10) à une interface de fixation (19) en s'étendant à partir d'une surface latérale intérieure (18) vers une surface latérale extérieure (17) de la lèvres d'essorage (16), à la surface inférieure terminale (14),

- des moyens d'ancrage supplémentaires (22), pour inhiber la séparation de la lèvres d'essorage (16) du corps principal (10) au moins lorsque la lèvres d'essorage (16) est déformée en direction dudit axe géométrique (X), **caractérisés en ce que** lesdits moyens supplémentaires d'ancrage (22) comprennent une structure de liaison (23) s'étendant le long de la paroi latérale extérieure (11) du corps principal (10), entre la lèvres d'essorage (16) et un élément de retenue (24) couplé au corps principal (10), dans une position espacée axialement de la lèvres d'essorage (16), où ladite lèvres d'essorage (16), la structure de liaison (23) et l'élément de retenue (24) sont construits d'une seule pièce, où la structure de liaison (23) comprend des tirants d'ancrage (25) s'étendant de manière parallèle audit axe géométrique (X) et ayant chacun une première extrémité reliée à la lèvres d'essorage (16) et une seconde extrémité reliée audit élément de retenue (24).

2. Dispositif selon la revendication 1, dans lequel au moins la lèvres d'essorage (16), qui a de préférence une conformation tronconique, est constituée d'un matériau plus doux que le matériau formant le corps principal (10).

3. Dispositif selon une ou plusieurs des revendications précédentes, dans lequel la lèvres d'essorage (16) est jointe au corps principal (10) par des liaisons moléculaires à l'interface de fixation (19).

4. Dispositif selon une ou plusieurs des revendications 1 à 3, dans lequel la lèvres d'essorage (16), la structure de liaison (23) et l'élément de retenue (24) sont construits d'une seule pièce, fabriquée par surmoulage par injection.

5. Dispositif selon une ou plusieurs des revendications précédentes, dans lequel ledit élément de retenue (24) présente une conformation annulaire et est relié à une extrémité du corps principal (10) en position opposée à la lèvres d'essorage (16).

6. Dispositif selon l'une ou plusieurs des revendications précédentes, dans lequel la structure de liaison (23) comprend en outre un élément de retenue auxiliaire (26) relié auxdits tirants d'ancrage (25) et se prolongeant de manière périmétrale par rapport au corps principal (10) dans une position intermédiaire entre la lèvres d'essorage (16) et l'élément de retenue (24).

7. Dispositif selon l'une ou plusieurs des revendications précédentes, dans lequel au moins un événement (27) est radialement formé à travers le corps principal (10).

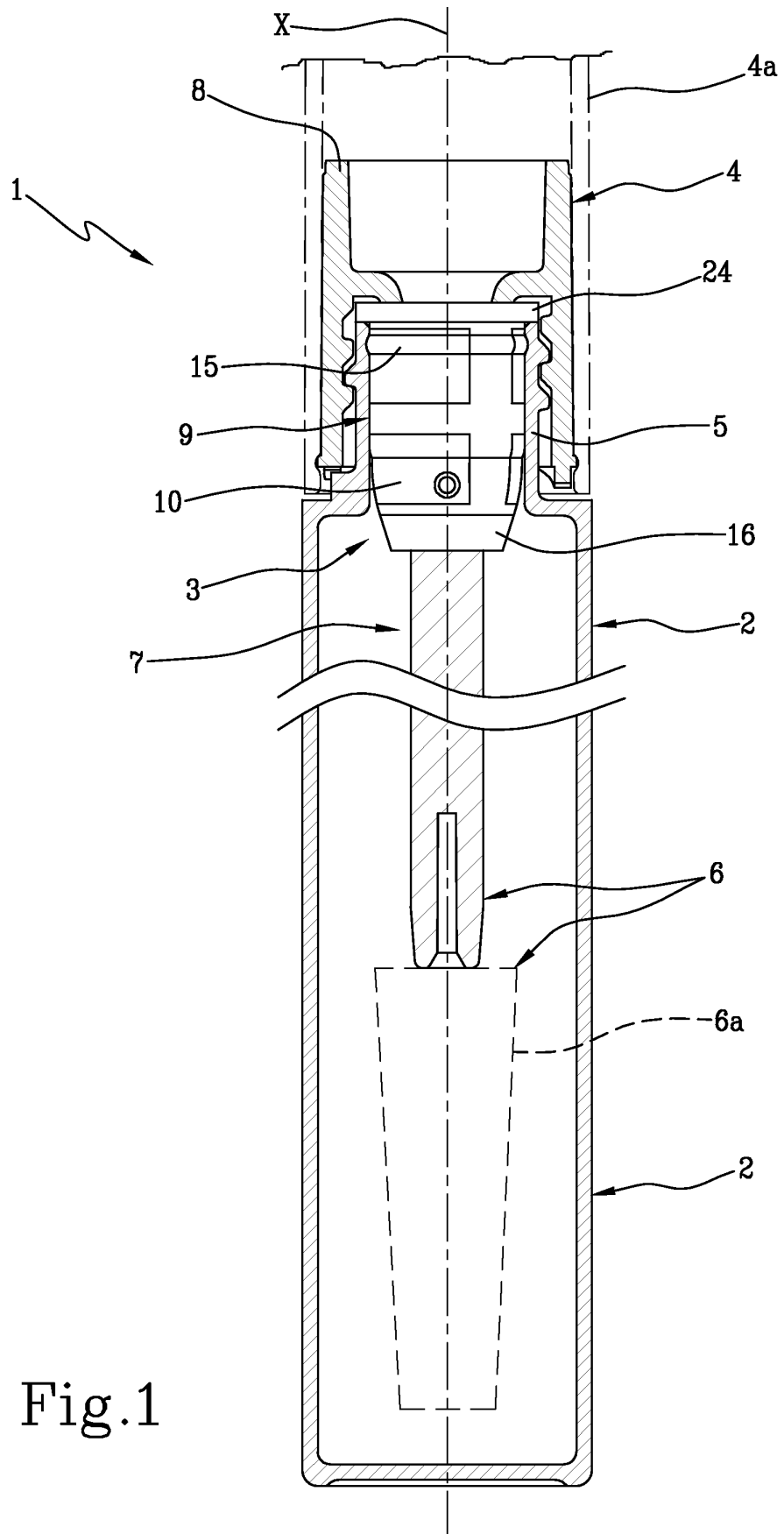

Fig.1

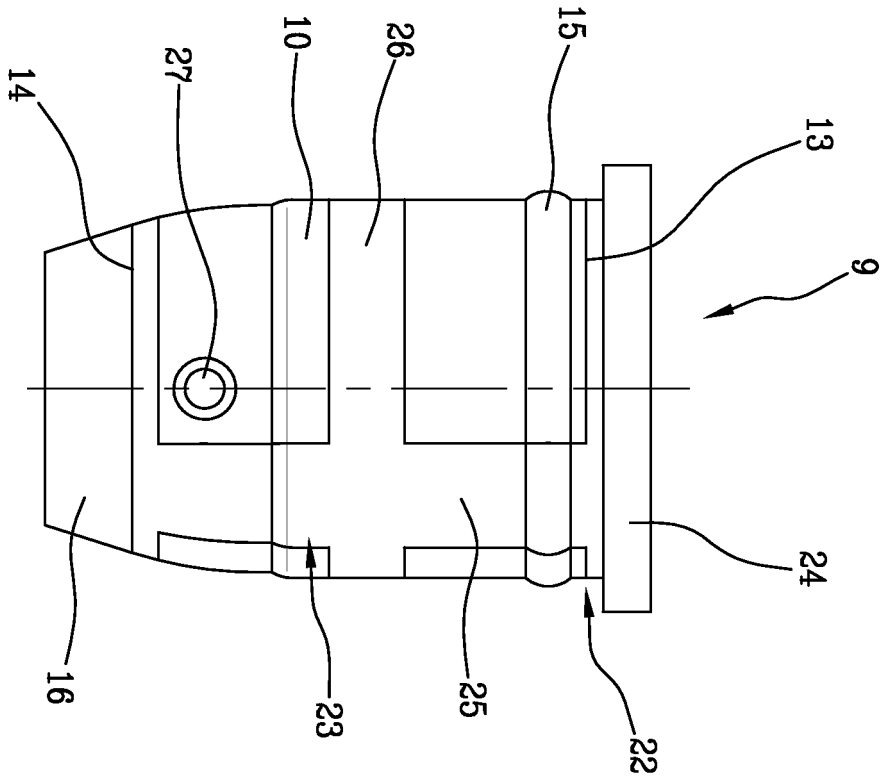

Fig. 2

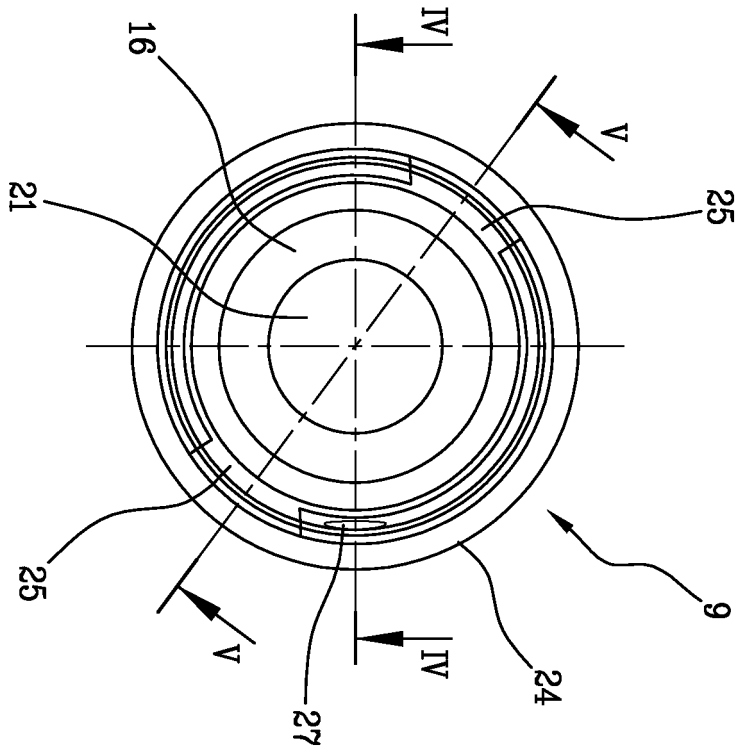

Fig. 3

Fig. 4

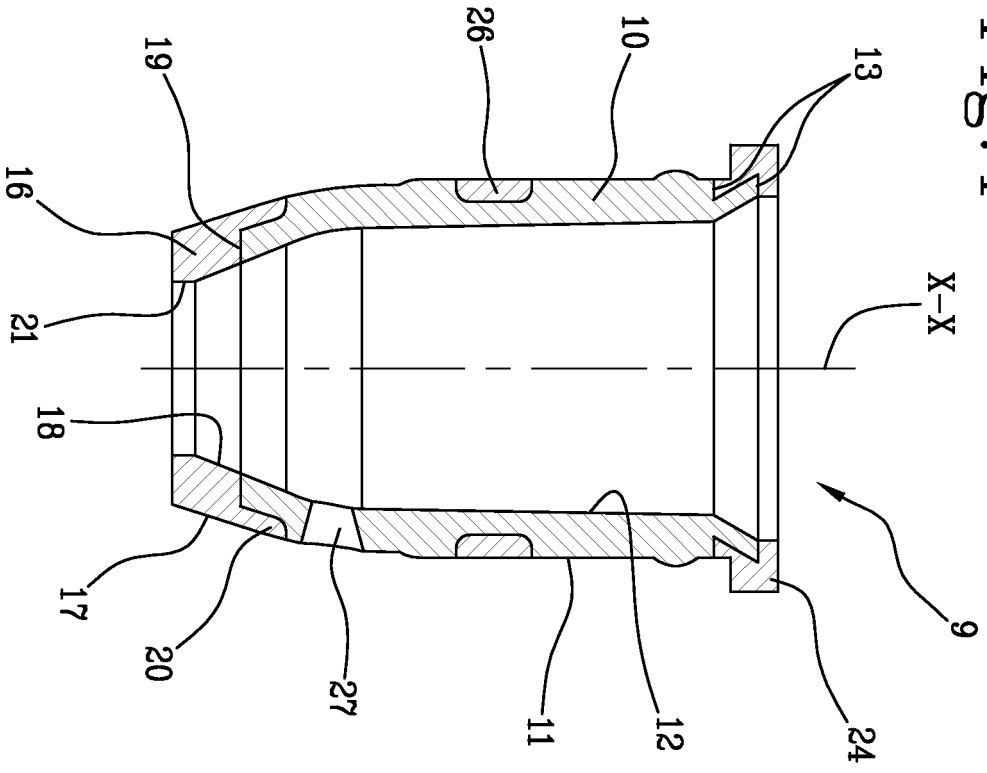
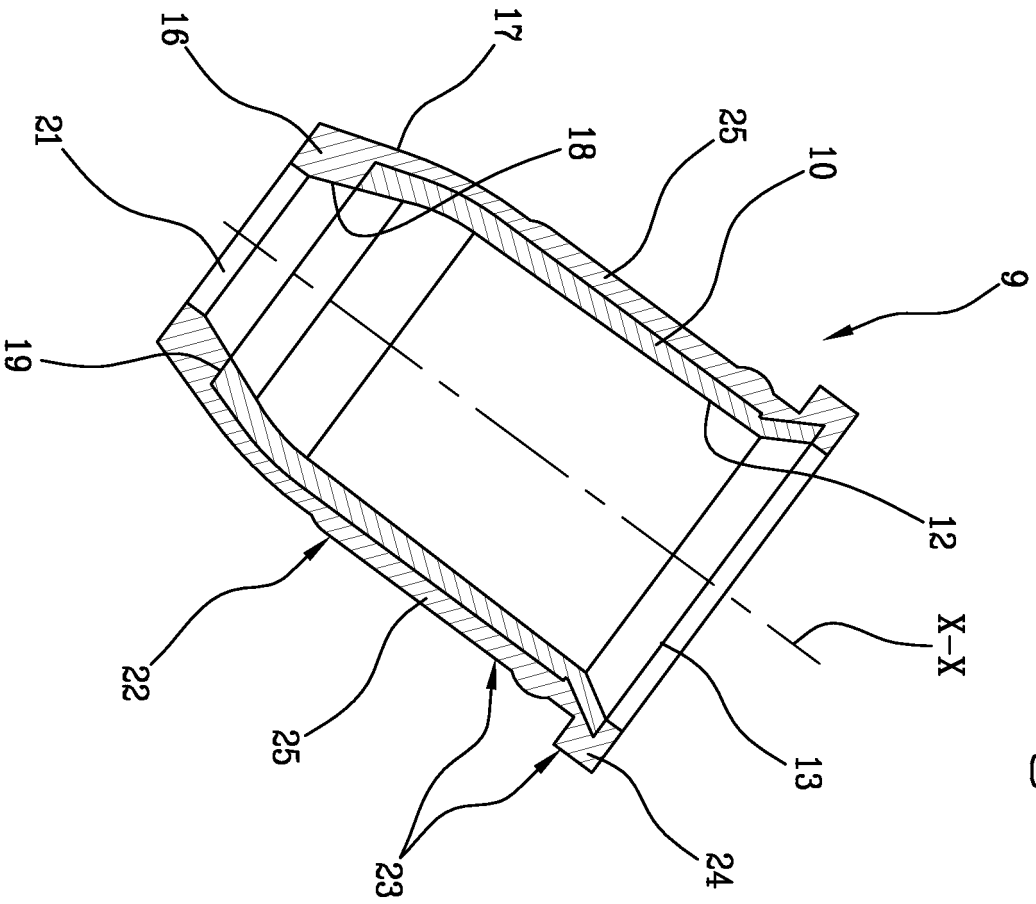

Fig. 5



REFERENCES CITED IN THE DESCRIPTION

This list of references cited by the applicant is for the reader's convenience only. It does not form part of the European patent document. Even though great care has been taken in compiling the references, errors or omissions cannot be excluded and the EPO disclaims all liability in this regard.

Patent documents cited in the description

- EP 1771099 A [0005]
- US 2002195117 A [0008]
- DE 102008035905 [0008]
- EP 350535 A [0008]