

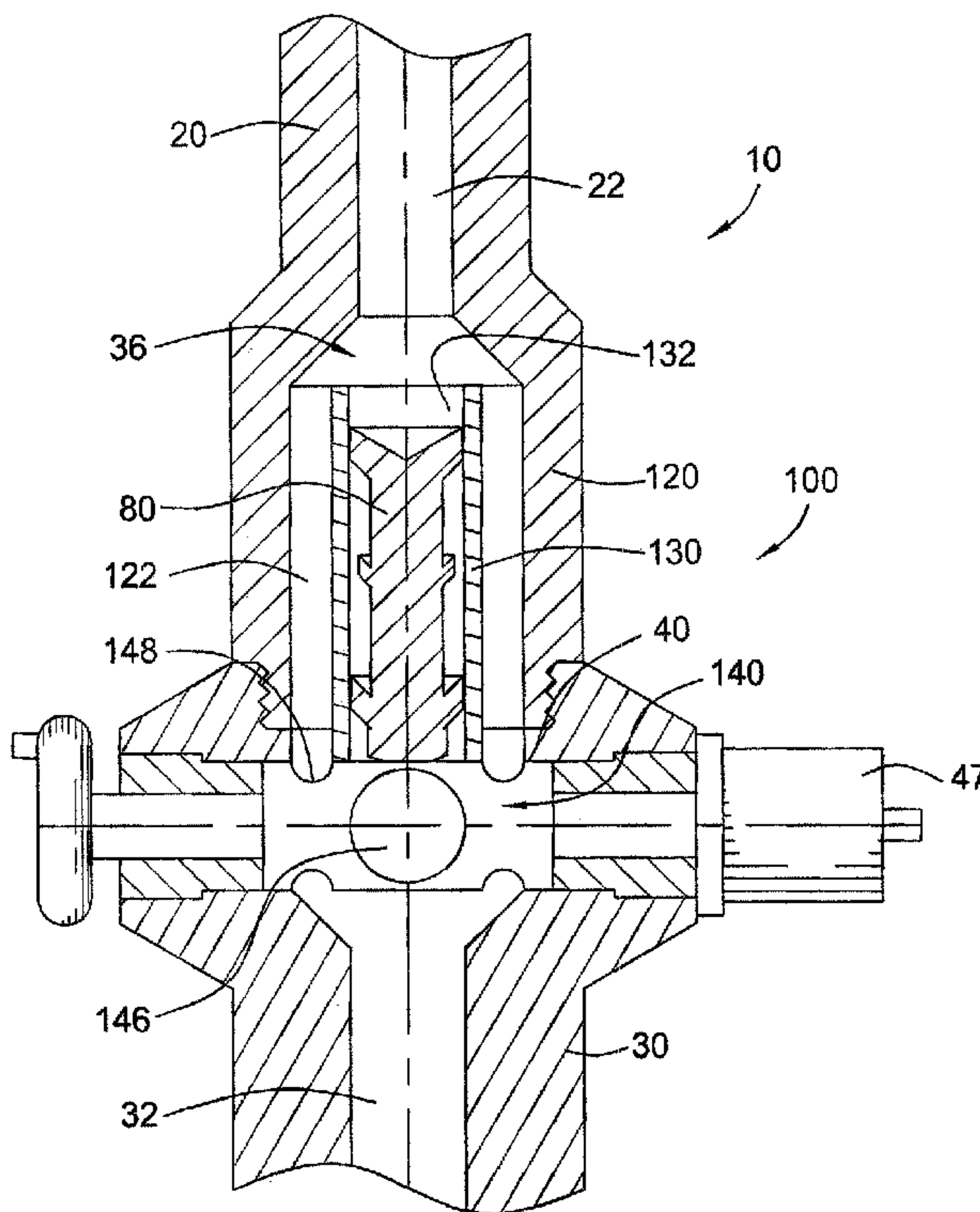

(22) Date de dépôt/Filing Date: 2004/07/08
(41) Mise à la disp. pub./Open to Public Insp.: 2005/01/10
(30) Priorité/Priority: 2003/07/10 (10/616,643) US

(51) Cl.Int.⁷/Int.Cl.⁷ E21B 33/05
(71) Demandeur/Applicant:
WEATHERFORD/LAMB, INC., US
(72) Inventeurs/Inventors:
PEDERSEN, GERALD D., US;
HIRTH, DAVID E., US
(74) Agent: DEETH WILLIAMS WALL LLP

(54) Titre : CONTENANT SERVANT A LA LIBERATION D'UN BOUCHON DANS UN Puits DE FORAGE
(54) Title: PLUG-DROPPING CONTAINER FOR RELEASING A PLUG INTO A WELLBORE



(57) **Abrégé/Abstract:**

The present invention relates to a plug-dropping container for releasing plugs or other objects into a wellbore during fluid circulation procedures. In one aspect, the plug-dropping container is used as part of a cementing head. The plug-dropping container comprises an elongated housing, and a canister disposed co-axially within the housing. The canister is configured to receive the plug, such as a drill pipe dart. A valve is disposed below the canister. The valve is movable from a plug-retained position where the plug is blocked, to a plug-released position where the plug may be released into the wellbore there below. In the plug-retained position, fluid is permitted to flow through the canister-housing annulus and around the valve.

ABSTRACT OF THE DISCLOSURE

The present invention relates to a plug-dropping container for releasing plugs or other objects into a wellbore during fluid circulation procedures. In one aspect, the plug-dropping container is used as part of a cementing head. The plug-dropping container comprises an elongated housing, and a canister disposed co-axially within the housing. The canister is configured to receive the plug, such as a drill pipe dart. A valve is disposed below the canister. The valve is movable from a plug-retained position where the plug is blocked, to a plug-released position where the plug may be released into the wellbore there below. In the plug-retained position, fluid is permitted to flow through the canister-housing annulus and around the valve.

PLUG-DROPPING CONTAINER FOR RELEASING A PLUG INTO A WELLBORE

RELATED APPLICATIONS

5 This application is a continuation-in-part of an earlier application entitled "PLUG-DROPPING CONTAINER FOR RELEASING A PLUG INTO A WELLBORE." That application was filed on January 31, 2002, and has U.S. Serial No. 10/066,460. The parent application is incorporated herein in its entirety by reference.

BACKGROUND OF THE INVENTION

10 Field of the Invention

 The present invention generally relates to an apparatus for dropping plugs into a wellbore. More particularly, the invention relates to a plug-dropping container for releasing plugs and other objects into a wellbore, such as during cementing operations.

Description of the Related Art

15 In the drilling of oil and gas wells, a wellbore is formed using a drill bit that is urged downwardly at a lower end of a drill string. After drilling a predetermined depth, the drill string and bit are removed and the wellbore is lined with a string of casing. An annular area is thus formed between the string of casing and the formation. A cementing operation is then conducted in order to fill the annular area with cement. The
20 combination of cement and casing strengthens the wellbore and facilitates the isolation of certain areas of the formation behind the casing for the production of hydrocarbons.

 It is common to employ more than one string of casing in a wellbore. In this respect, a first string of casing is set in the wellbore when the well is drilled to a first designated depth. The first string of casing is hung from the surface, and then cement
25 is circulated into the annulus behind the casing. The well is then drilled to a second designated depth, and a second string of casing, or liner, is run into the well. The second string is set at a depth such that the upper portion of the second string of casing overlaps the lower portion of the first string of casing. The second liner string is then fixed or "hung" off of the existing casing. Afterwards, the second casing string is also

cemented. This process is typically repeated with additional liner strings until the well has been drilled to total depth. In this manner, wells are typically formed with two or more strings of casing of an ever-decreasing diameter.

5 In the process of forming a wellbore, it is sometimes desirable to utilize various plugs. Plugs typically define an elongated elastomeric body used to separate fluids pumped into a wellbore. Plugs are commonly used, for example, during the cementing operations for a liner.

10 The process of cementing a liner into a wellbore typically involves the use of liner wiper plugs and drill-pipe darts. A liner wiper plug is typically located inside the top of a liner, and is lowered into the wellbore with the liner at the bottom of a working string. The liner wiper plug has radial wipers to contact and wipe the inside of the liner as the plug travels down the liner. The liner wiper plug has a cylindrical bore through it to allow passage of fluids.

15 After a sufficient volume of circulating fluid or cement has been placed into the wellbore, a drill pipe dart or pump-down plug, is deployed. Using drilling mud, cement, or other displacement fluid, the dart is pumped into the working string. As the dart travels downhole, it seats against the liner wiper plug, closing off the internal bore through the liner wiper plug. Hydraulic pressure above the dart forces the dart and the wiper plug to dislodge from the bottom of the working string and to be pumped down the
20 liner together. This forces the circulating fluid or cement that is ahead of the wiper plug and dart to travel down the liner and out into the liner annulus.

25 Typically, darts used during a cementing operation are held at the surface by plug-dropping containers. The plug-dropping container is incorporated into the cementing head above the wellbore. Fluid is directed to bypass the plug within the container until it is ready for release, at which time the fluid is directed to flow behind the plug and force it downhole. Existing plug-dropping containers, such as cementing heads, utilize a variety of designs for allowing fluid to bypass the plug before it is released. One design used is an externally plumbed bypass connected to the bore body of the container. The external bypass directs the fluid to enter the bore at a point

below the plug position. When the plug is ready for release, an external valve is actuated to direct the fluid to enter the bore at a point above the plug, thereby releasing the plug into the wellbore.

Another commonly used design is an internal bypass system having a second
5 bore in the main body of the cementing head. In this design, fluid is directed to flow into the bypass until a plug is ready for release. Thereafter, an internal valve is actuated and the flow is directed on to the plug.

There are disadvantages to both the external and internal bypass plug
10 container systems. Externally plumbed bypasses are bulky because of the external manifold used for directing fluid. Because it is often necessary to rotate or reciprocate the plug container, or cementing head, during operation, it is desirable to maintain a compact plug container without unnecessary projections extending from the bore body. As for the internal bypass, an internal bypass requires costly machining and an internal valve to direct fluid flow. Additionally, the internal valve is subject to erosion by cement
15 and drilling fluid.

In another prior art arrangement, a canister containing a plug is placed inside the bore of the plug container. The canister initially sits on a plunger. Fluid is allowed to bypass the canister and plunger until the plug is ready for release. Upon release from the plunger, the canister is forced downward by gravity and/or fluid flow and lands
20 on a seat. The seat is designed to stop the fluid from flowing around the canister and to redirect the flow in to the canister in order to release the plug. However, this design does not utilize a positive release mechanism wherein the plug is released directly. If the cement and debris is not cleaned out of the bore, downward movement of the canister is impeded. This, in turn, will prevent the canister from landing on the seat so
25 as to close off the bypass. If the bypass is not closed off, the fluid is not redirected through the canister to force the plug into the wellbore. As a result, the plug is retained in the canister even though the canister is "released."

The release mechanism in some of the container designs described above involves a threaded plunger that extends out from the bore body of the container, and
30 requires many turns to release the plug. The plunger adds to the bulkiness of the

container and increases the possibility of damage to the head member of the plug container. Furthermore, cross-holes are machined in the main body for plunger attachment. Because a plug container typically carries a heavy load due to the large amount of tubular joints hanging below it, it is desirable to minimize the size of the cross-holes because of their adverse effect on the tensile strength of the container.

In order to overcome the above obstacles, plug-dropping containers have been developed that allow release of a dart by rotating a cylindrical valve that allows the dart to pass through an internal channel and at the same time redirect the flow path to be through the canister. Known plug dropping containers of this configuration have valve designs that are complex to manufacture and require the flow to traverse a tortuous and often restricting path in the bypass position.

An example of such a plug-dropping container is shown at **100** in the Prior Art view of **Figure 1**. The plug-dropping container **100** first comprises a housing **120**. The housing **120** defines a tubular body having a top end, a bottom end, and having a fluid channel **122** therebetween. In **Figure 1**, the housing **120** is shown disposed within a cementing head **10**. The upper end of the housing **120** may be threadedly connected to an upper body portion **20** of the cementing head **10**, or may be integral as shown in **Figure 1**. This exemplary plug-dropping container of **Figure 1** is shown in Figure 3 of U.S. Patent No. 5,890,537 issued to Lavaure, *et al.* in 1999, and is described more fully therein.

Disposed generally co-axially within the housing **120** is a canister **130**. The canister **130** is likewise a tubular shaped member which resides within the housing **120** of the plug-dropping container **100**. This means that the outer diameter of the canister **130** is less than the inner diameter of the housing **120**. At the same time, the inner diameter of the canister **130** is dimensioned to generally match the inner diameter of fluid flow channel **22** for the cementing head **10**. As with the housing **120**, the canister **130** has a top opening and a bottom opening. In the arrangement shown in **FIG. 1**, the top opening of the canister **130** is in fluid communication with the upper fluid flow channel **22**. A simple slip fit is typically provided. The canister **130** has a fluid flow channel **132** placed along its longitudinal axis. The fluid flow channels **122**, **132** for the

housing **120** and for the canister **130**, respectively, are co-axial with the fluid flow channel **22** for the cementing head **10**.

A dart **80** is shown placed within the canister **130**. The dart **80** is retained within the canister **130** by a plug-retaining valve **140** (shown more fully in **FIGS. 2A-2B**).
5 The purpose of the plug-retaining valve **140** is to allow the drilling operator to selectively release a dart **80** or other plug into the wellbore. To this end, the valve **140** is constructed to have a plug-retained position, and a plug-released position. Fluid circulation is maintained in both positions of the valve **140**.

10 A bypass area **36** is provided above the canister **130**. The bypass area **36** permits fluid to be diverted into an annular region **126** around the canister **130** when the valve **140** is in its plug-retained position.

Figure 2A presents an isometric view of the plug-retaining valve **140** designed to fit into the opening **40** in the plug-dropping container **100** of **Figure 1**. **Figure 2B** is a longitudinal cross-sectional view of the prior art valve **140** of **Figure 2A**,
15 with the view taken across **line B-B** of **Figure 2A**.

The valve **140** defines a short, cylindrical body having walls **144, 144'**. The walls **144, 144'** have an essentially circular cross-section. The wall **144'** is configured to inhibit the flow of fluids from the canister **130** when the valve **140** is rotated to its plug-retained position.

20 Various openings are provided along the walls **144, 144'** of the plug-retaining valve **140**. First, one or more bypass openings **148** are placed at ends of the valve **140**. **Figure 2A** presents a pair of bypass openings **148**. The bypass openings **148** are also seen in the **Figure 2B**, which is a cross-sectional view of the plug-retaining valve **140** taken across **line B-B** of **Figure 2A**. The bypass openings **148** receive fluid from the
25 housing-canister annulus **122** when the valve **140** is in its plug-retained position. From there, fluid exits the valve **140** into the lower channel **32**.

The plug-retaining valve **140** is designed to be rotated about a pivoting connection between plug-retained and plug-released positions. Rotation is preferably accomplished by turning a shaft **47** (shown in **FIG. 1**).

The plug-retaining device **140** also has a fluid channel **146** fabricated therein. The fluid channel **146** is oriented normal to the longitudinal axis of the valve **140**. In addition, the longitudinal axis of the channel **146** is normal to the axis of rotation of the plug-retaining device **100** when rotating between the plug-retained and plug-released positions. The channel **146** is dimensioned to receive the dart **80** when the plug-retaining device **140** is rotated into its plug-released position during a cementing or other fluid circulation operation. The channel **146** is seen in the isometric view of **Figure 2A**, as well as in the cross-sectional view of **Figure 2B**.

The housing for the plug-retaining valve **140** from the prior art is cumbersome to manufacture. In this respect, the housing for the valve **140** requires extensive machining to form mating bores for openings **148**.

Therefore, there is a need for plug-dropping container for a cementing head having an improved plug-retaining mechanism. There is a further need for a plug-dropping container that is easier and less expensive to manufacture. Still further, there is a need for a plug-dropping container that provides a less restrictive and less tortuous fluid flow path in its plug-retained position.

SUMMARY OF THE INVENTION

The present invention generally relates to a plug-dropping container for use in a wellbore circulating operation. An example of such an operation is a cementing operation for a liner string. The plug-dropping container first comprises a tubular housing having a top end and a bottom end. The top end is in sealed fluid communication with a wellbore fluid circulation device, such as a cementing head. Thus, fluid injected into the cementing head will travel through the housing before being injected into the wellbore.

The plug-dropping container also comprises a canister disposed co-axially within the housing. The canister is likewise tubular in shape so as to provide a fluid channel therein. The canister has a top opening and a bottom opening, and is dimensioned to receive plugs, such as drill pipe darts, therethrough. An annulus is defined between the canister and the surrounding housing. Un upper bypass area is formed proximal to the top end of the canister, thereby permitting fluids to flow from the cementing head, through the bypass area, and into the annular region between the canister and the surrounding housing.

A plug-retaining valve is provided proximal to the lower end of the canister. The valve is used to retain one or more plugs until release of the plug into the wellbore is desired. In this respect, the plug-retaining valve is movable between a plug-retained position where the plug is blocked, to a plug-released position where the plug may be released from the canister and into the wellbore there below.

The plug-retaining valve has a solid surface that blocks release of the plug in the plug-retained position. At the same time, and contrary to the prior art valve of **Figures 1 and 2A-2B**, the valve permits fluid to flow through the annulus and around the valve. The valve also has a channel there through that receives the plug when the valve is moved to its object-released position.

In one aspect, the plug-retaining valve is a spherical member having a fluid channel therein. One portion of the spherical valve is truncated, creating a flat surface. Thus, the plug-retaining valve is eccentrically configured so that it has a substantially flat surface, and a radial surface. The radial surface is dimensioned to substantially seal the bottom end of the canister when the plug-retaining device is in its plug-retained position.

When the plug-dropping container is in its plug-retained position, the plug-retaining valve is oriented such that the radial surface of the plug-retaining device blocks the downward flow of the dart. In this position, the dart and the plug-retaining valve prohibit the flow of fluid through the canister; instead, fluid travels through the bypass ports, around the canister, through the canister-housing annulus, around the flat

surface of the valve, and into the wellbore. At the point at which plug-release is desired, the valve is rotated 90 degrees, aligning the fluid channel with the channel of the canister. At the same time, the bypass is substantially shut off by the radial surface around the perimeter of one end of the valve fluid channel closing off the gap between
5 the valve and the upper opening of the lower head channel. The plug-retaining valve then permits both the dart and fluids to flow directly through the canister and into the wellbore.

In one aspect, a travel stop is provided to limit the rotation of the device to 90 degrees. The travel stop ensures that the radial surface of the plug-retaining valve is
10 always blocking the dart when the valve is in its plug-retained position, and that the fluid channel is aligned with the channel in the canister when the valve is in its plug-released position.

In another embodiment, one or more plug-dropping containers of the present invention may be stacked for sequential release of more than one dart during a
15 cementing (or other fluid circulation) operation.

BRIEF DESCRIPTION OF THE DRAWINGS

So that the manner in which the above recited features of the present invention are attained and can be understood in detail, a more particular description of the invention, briefly summarized above, may be had by reference to the appended
20 drawings. It is to be noted, however, that the appended drawings (Figures 3 through 10D) illustrate only typical embodiments of this invention and are therefore not to be considered limiting of its scope, for the invention may admit to other equally effective embodiments.

Figure 1 is a partial cross-sectional view of a prior art cementing head having
25 a plug-dropping container. Visible in this view is a canister for receiving a plug such as a drill pipe dart through the cementing head. Also visible is a plug-retaining valve for selectively releasing the plug into the wellbore below.

Figure 2A is an isometric view of the valve from the plug-dropping container of Figure 1.

Figure 2B is a longitudinal cross-sectional view of the prior art valve of Figure 2A, with the view taken across line B-B of Figure 2A.

5 Figure 3 is a front, cross-sectional view of a plug-dropping container of the present invention, in its plug-retained position. An upper housing, lower housing, and intermediate housing are seen. In this view, a novel plug-retaining valve is in its closed position, blocking release of a plug.

10 Figure 4 is a side, cross-sectional view of the plug-dropping container of Figure 3, in its plug-retained position.

Figure 5A is an isometric view of the plug-retaining valve of the plug-dropping container of Figure 3. In this view, a flat side of the valve is on the bottom.

15 Figure 5B presents another isometric view of the plug-retaining valve of the plug-dropping container of Figure 3. In this view, the valve has been rotated for additional viewing of features of the valve.

Figure 5C is also an isometric view of the plug-retaining valve from Figure 3. In this view, the bore through the valve is seen in phantom.

Figure 5D is a front, perspective view of the plug-retaining valve of Figure 5B.

20 Figure 5E is a side, cross-sectional view of the plug-retaining valve of Figure 5B. The cut is taken across line E-E of Figure 5D.

Figure 5F represents another cross-sectional view of the plug-retaining valve of Figure 5B. The cut is taken across line F-F of Figure 5D.

Figure 6 is a front, cross-sectional view of the plug-dropping container of Figure 3. In this front view, the plug-retaining-valve has been rotated to its plug-

released position, allowing the dart to be released through the valve channel and down into the wellbore.

Figure 7 is a side, cross-sectional view of the plug-dropping container of Figure 6, in its plug-released position.

5 Figure 8A is a cross-sectional view of an alternative embodiment of a plug-dropping container of the present invention. In this view, two plug-dropping containers are stacked, one on top of the other. Both plug-dropping containers are in the plug-retained position, thereby blocking the release of darts.

10 Figure 8B is a schematic view of the plug-dropping container of Figure 8A. In this view, the lower plug-retaining valve has been rotated to release the lower dart.

Figure 8C is a schematic view of the plug-dropping container of Figure 8B. Again, two plug-dropping containers are stacked one on top of the other. In this view, the upper plug-retaining valve has been rotated to release the top dart into the wellbore.

15 Figure 9A is a cross-sectional view of still another embodiment of a plug-dropping container of the present invention. In this arrangement, the plug-retaining device is a curved flapper. Here, the flapper is in its closed position, preventing the downward release of the dart.

20 Figure 9B presents a transverse view of the plug-dropping container of Figure 9A. The view is taken through line B-B of Figure 9A. Visible in this view is the flapper, and a shaft for rotating the flapper.

Figure 9C is a cross-sectional view of the plug-dropping container of Figure 9A, in its plug-released position. Here, the flapper has been rotated from a plug-retained position to its plug-released position. It can be seen that the dart is now being released into a wellbore there below.

25 Figure 9D provides a cross-sectional view of the plug-dropping container of Figure 9C, with the view taken through line D-D of Figure 9C. It can be more clearly

seen that the flapper has been rotated from its plug-retained position against the seat to its plug-released position covering the bypass opening.

Figure 10A is a cross-sectional view of yet another embodiment of a plug-dropping container of the present invention. In this arrangement, the plug-retaining device is a horizontal plate. Here, the plate is in its closed position, preventing the downward release of the dart.

Figure 10B presents a transverse view of the plug-dropping container of Figure 10A. The view is taken through line B-B of Figure 10A. Visible in this view is the plate, and a shaft and gear for moving the plate horizontally.

Figure 10C is a cross-sectional view of the plug-dropping container of Figure 10A, in its plug-released position. Here, the plate has been translated from a plug-retained position to its plug-released position. It can be seen that the dart is now being released into a wellbore there below.

Figure 10D provides a cross-sectional view of the plug-dropping container of Figure 10C, with the view taken through line D-D of Figure 10C. It can be more clearly seen that the plate has been translated from its plug-retained position to its plug-released position

DETAILED DESCRIPTION OF THE PREFERRED EMBODIMENT

Figure 3 presents a front view of a plug-dropping container 300 of the present invention, in one embodiment. The plug-dropping container 300 is shown in cross-section with a dart 80 disposed therein. The plug-dropping container 300 is in its plug-retained position. In this way, the dart 80 is retained within the plug-dropping container 300.

Figure 4 presents a side view of the plug-dropping container 300 of Figure 1. The plug-dropping container 300 is again in its plug-retained position. The dart 80 is again seen being held within the container 300 before release into a wellbore (not shown) therebelow.

The plug-dropping container **300** is designed for use in a wellbore circulating system. An example of such a system is a cementing head **10** as might be used for cementing a liner string. The views of **Figure 3** and **Figure 4** include upper **20** and lower **30** body portions of a cementing head **10**. The body portions **20**, **30** include
5 respective fluid flow channels **22**, **32**. The fluid flow channels **22**, **32** permit fluid to be circulated from the surface into the wellbore. The plug-dropping container **300** is preferably disposed intermediate the upper **20** and lower **30** body portions, as shown in **Figures 3** and **4**.

As with the prior art plug-dropping container **100** of **FIG. 1**, the novel plug-
10 dropping container **300** of **FIG. 3** first comprises a housing **320**. The housing **320** defines a tubular body having a top end, a bottom end, and having a fluid channel **322** therebetween. In **Figure 3**, the housing **320** is shown disposed within the cementing head **10**. The upper end of the housing **320** is connected to the upper body portion **20** of the cementing head **10**. Likewise, the lower end of the housing **320** is connected to
15 the lower body portion **30** of the cementing head **10**. Preferably the connection is constructed so as to place the fluid flow channel **322** for the housing **320** co-axial with the fluid flow channels **22**, **32** for the cementing head **10**.

Disposed within the housing **320** is an elongated canister **330**. The canister **330** is a tubular shaped member which resides within the housing **320** of the plug-
20 dropping container **300**. This means that the outer diameter of the canister **330** is less than the inner diameter of the housing **320**. At the same time, the inner diameter of the canister **330** is dimensioned to generally match the inner diameter of the fluid flow channels **22**, **32** for the cementing head **10**. As with the housing **320**, the canister **330** has a top opening and a bottom opening. In the arrangement shown in **FIG. 3**, the top
25 opening of the canister **330** is in fluid communication with the upper fluid flow channel **22**. In one aspect, a threaded connection is provided between the top end of the canister **330** and the lower end of the upper cementing head body **20**. In the arrangement shown in **Figure 3**, though, a simple slip fit is provided. However, it is understood that the present invention **300** is not limited as to the manner in which the
30 canister **330** is held within the cementing head **10**.

A channel **332** is formed within the canister **330** between the top and bottom ends. The channel **332** is configured to closely receive and retain a plug **80** such as a drill pipe dart when the plug-dropping container **300** is in its plug-retained position. In the view of **FIG. 3**, a dart **80** is being retained within the channel **332** by a novel plug-retaining valve **340**. Thus, the plug-releasing container **300** is in its plug-retained position.

The canister **330** is generally co-axially aligned within the tubular housing **320**. Preferably, the canister **330** is centralized within the tubular housing **320** by spacers **334** positioned between the outer wall of the canister **330** and the inner wall of the housing **320**. The spacers **334** are preferably attached to the outer wall of the canister **330**, as shown in **Figure 3**. Alternatively, the spacers **334** may be attached to the inside of the tubular housing **320**. The spacers **334** are configured so as to allow fluid to flow through the annulus.

A fluid bypass area **336** is provided proximal to the top end of the canister **330**. The bypass area **336** may be simply a gap between the top of the canister **330** and the upper head member **20**. In the arrangement of **Figures 3** and **4**, the bypass area **336** defines one or more bypass ports formed in the canister **330**. The bypass ports **336** are disposed above the position of the dart **80** in the canister **330**. The bypass ports **336** permit fluid circulating downhole to be diverted into the annular fluid channel **322** of the housing **320** (between the canister **330** and the housing **320**).

The canister **330** is designed to be of a generally equivalent length as compared to the housing **320**. The exact relative lengths of the housing **320** and the canister **330** are variable, so long as a spacing is provided for the plug-retaining valve **340**, and to permit fluid to bypass the canister channel **332** and travel into the lower head channel **32** en route to the wellbore. In one arrangement, a gap **328** (shown in **FIGS. 3** and **4**) is provided under the valve **340** and above the lower cement body **30**.

As with the prior art plug-dropping container **100**, the plug-dropping container **300** of the present invention provides a space **40** for a plug-retaining valve. However, in the arrangement in **Figures 3** and **4**, a novel valve **340** is provided. The valve **340** is

configured to permit fluid to flow around the valve **340** when the valve **340** is in its plug-retained position, rather than only through milled ports. This potentially simplifies the manufacturing process.

Figure 5A presents an isometric view of the plug-retaining valve **340** of the plug-dropping container **300** of **Figure 3**. In this arrangement, the valve **340** generally defines a spherical body having a radial surface **344R**. The valve **340** is truncated in order to form a substantially flat surface **344F**. Thus, the valve **340** has a radial surface **344R**, and an opposing flat surface **344F**. The radial surface **344R** of the valve **340** is dimensioned to substantially seal against the canister **330** when the valve **340** is in its plug-retained orientation and to substantially close the bypass flow when the valve **340** is in its plug-released orientation. In the view of **Figure 5A**, the flat surface **344F** is on the bottom.

A fluid channel **342** is formed through the valve **340**. The fluid channel **342** is dimensioned to closely receive a drill pipe dart **80** or other plug, permitting the dart **80** to pass through the valve **340**. This occurs when the valve **340** is in its plug-released position (shown later in **Figures 6** and **7**). In one arrangement, the fluid channel **342** is axially aligned with the flat surface **344F**. Also, as will be noted, the longitudinal axis of the channel **342** is normal to the axis of rotation of the valve **340** when it is rotated between plug-retained and plug-released positions.

Figures 5B and **5C** present additional isometric views of the valve **340** of **Figure 5A**. The valve **340** is rotated for clarification of the views. In **Figure 5C**, the fluid channel **342** is seen in phantom.

Figure 5D is a front, perspective view of the plug-retaining valve **340** of **Figure 5A**. In this view, the valve **340** is oriented as in **Figure 3**. This means that the valve **340** would be in its plug-retained position within the plug-dropping container **300**. Visible at the top of the valve **340** in this orientation is the radial surface **344R**. The flat surface **344F** is at the bottom of the valve **340**. The fluid channel **342** is shown in phantom.

The plug-retaining valve **340** is designed to be rotated between plug-retained and plug-released positions. To accomplish this rotation, shafts **347** project from opposing sides of the valve **340**. The shafts **347** are perpendicular to the fluid channel **342**. The shafts **347** extend through the wall of the cementing head **10** for turning the plug-retaining valve **340**. The shaft **347** may be rotated manually. Alternatively, rotation may be power driven, or may be remotely operated by a suitable motor or drive means (not shown). It is preferred that the shafts extend on opposite sides of the cementing head **10** for pressure balancing. By turning the shaft **347**, an operator may rotate the plug-retaining valve **340** between plug-retained and plug-released positions. It is understood that any arrangement for rotating the plug-retaining valve **340** is within the scope of the present invention.

Figure 5E is a side, cross-sectional view of the plug-retaining valve **340** of **Figure 5A**. The cut is taken across line **E-E** of **Figure 5D**. **Figure 5F** is a cross-sectional view of the plug-retaining valve **340** of **Figure 5A**. The view is taken across line **F-F** of **Figure 5D**.

Referring back to **Figure 3**, **Figure 3** again presents the plug-dropping container **300** in its plug-retained position. In this view, the radial surface **344R** of the valve **340** is oriented upwards in order to block downward release of the dart **80**, and to substantially seal the lower end of the canister channel **332**. In this way, the downward progress of the dart **80** is blocked. It is noted that the radial surface **344R** of the valve **340** is dimensioned to be able to rotate along the bottom end of the canister **330**, and to substantially restrict the flow of fluids through the canister **330** when the valve **340** is in its plug-retained position. This causes fluids flowing from the upper head channel **22** to be diverted through the bypass ports **336** of the canister, and downward through the canister-housing annulus **322**. From there, fluids flow around the plug-retaining valve **340** and through the gap **328** below the valve **340**. Fluids then proceed into the wellbore through the channel **32** in the lower cementing head body **30**.

In order to release the dart **80**, the plug-retaining valve **340** is rotated into its plug-released position. To accomplish this, the valve **340** is rotated 90 degrees so as to

align the channel opening **342** with the canister channel **332** and the lower cementing head channel **32**. The valve's **340** plug-released position is shown in **Figure 6**. **Figure 6** presents a front, cross-sectional view of the plug-dropping container **300** of **Figure 3**. In this front view, the valve **340** has been rotated to its plug-released position. The fluid
5 channel **342** of the valve **340** is now aligned with the channel **332** of the canister **330**, and the radial surface **344R** of the valve **340** is no longer blocking downward progress of the dart **80**. Further, in the plug-released position of the valve **340**, the radial surface **344R** is proximate to the lower body **30** substantially closing the gap **328**. Thus, fluid no longer is allowed to pass through the annular fluid channel **322**, but is forced to flow
10 through the canister channel **332**. This fluid flow along with gravity, forces the dart **80** downhole.

Figure 7 is a side view of the plug-dropping container **300** of **Figure 6**. The flat surface **344F** of the valve **340** is not visible in this view. However, in both **FIG. 6** and **FIG. 7**, a dart **80** is being released into the wellbore below.

15 A stop member **348** is optionally provided above the lower portion of the head member **30**. In **FIGS. 3** and **6**, the stop member **348** is seen as a shoulder extending upwards from the lower head member **30**. However, other arrangements for a stop member **348** may be employed. The purpose of the stop member **348** is to serve as a "no-go" or "travel stop" with respect to the rotation of the plug-retaining valve **340**. The
20 result is that the valve **340** can only be rotated 90 degrees.

In many cementing operations, two plugs are released during sequential fluid circulation stages. In order to accommodate the release of two plugs, an alternate embodiment of the plug container is provided. **Figure 8A** is a cross-sectional view of an alternative embodiment of a plug-dropping container of the present invention. In this
25 view, two plug-dropping containers **300'**, **300''** are stacked, one on top of the other. Each plug-dropping container **300'**, **300''** is in the plug-retained position, thereby blocking the release of upper **180** and lower **280** darts.

In operation, two plug-dropping containers **300'**, **300''** according to the present invention are disposed within a head member **10**, and stacked one on top of the

other. Each tool **300'**, **300''** includes a tubular housing **320'**, **320''**, and a respective canister **330'**, **330''** disposed within the respective housings **320'**, **320''**. Each plug-retaining tool **300'**, **300''** also provides a valve **340'**, **340''** for selectively retaining and releasing a dart **180**, **280**. The valves **340'**, **340''** are designed in accordance with the
5 valve **340** described above and shown in **FIGS. 3** and **6**.

As illustrated in **Figure 8A**, the tools **300'**, **300''** are initially in their plug-retained positions. Darts **180** and **280** are disposed in the upper **300'** and lower **300''** tools, respectively. Dart **180** is held within the upper canister **330'** and retained by the upper valve **340'**. In this respect, the upper valve **340'** is rotated so that the radial
10 surface **344R** impedes the downward progress of the dart **180**. This also serves to substantially inhibit the flow of fluids through the upper canister **330'**. Likewise, dart **280** is held within the lower canister **330''** and retained by a lower valve **340''**. In this respect, the lower valve **340''** is also rotated so that the radial surface **344R** impedes the downward progress of the dart **280**. This also serves to substantially inhibit the flow
15 of fluids through the lower canister **330''**.

The top of the upper housing **320'** is fluidly connected to the bottom of the upper head body **20**. The bottom of the lower housing **320''** is fluidly connected to the top of the lower head body **30**. Intermediate the upper and lower head bodies **20**, **30** the upper and lower housings **320'**, **320''** are connected. In the arrangement of **FIG.**
20 **8A**, the bottom end of the upper housing **320'** is threadedly connected to the top end of the lower housing **320''**. In this way, the upper and lower housings **320'**, **320''** essentially form a single tubular housing. Centralizers **334** are optionally placed around the upper **330'** and lower **330''** canisters, respectively, to aid in centralizing the canisters **330'**, **330''** within the respective housings **320'**, **320''**.

25 In operation, drilling fluid, or other circulating fluid, is introduced into the upper cementing head body **20** through a fluid flow channel **22**. Because the upper valve **340'** is in its plug-retained position, fluid is not able to flow through the upper canister **330'**. A fluid bypass area **336'** is provided proximal to the top end of the canister **330'**. The bypass area **336'** may be simply a gap between the top of the canister **330'** and the

upper head member **20**. In the arrangement shown the bypass area defines bypass ports **336'** placed in the upper canister **330'**, permitting fluid to flow around the upper canister **330'** and through an upper fluid flow channel **322'** of the upper housing **320'**. Preferably, the bypass ports **336'** are proximate to the top end of the upper canister

5 **330'**.

The upper housing fluid flow channel **322'** defines the annular region between the upper canister **330'** and the upper housing **320'**. From there, fluid travels around the upper valve **340'**, and enters a gap **328'** below the upper valve **340'**. Fluid then enters the lower canister **330''** of the lower tool **300''**.

10 It is again noted that the lower valve **340''** is also in its plug-retained position. This means that fluid is not able to flow through the lower canister **330''**, at least not in any meaningful fashion. A fluid bypass area **336''** is provided proximal to the top end of the canister **330''**. The bypass area **336'** may be simply a gap between the top of the canister **330''** and the upper head member **20**. In the arrangement shown, one or more

15 bypass ports **336''** are placed proximate to the top of the lower canister **330''**. The bypass ports **336''** allow fluid to progress downwardly through the fluid channel **322''** of the lower housing **320''**. From there, fluid exits a lower gap **328''** disposed below the lower valve **340''**. Fluid then enters the fluid channel **32** in the lower head body **30**. The lower head body **30** may be a tubular in a cementing head or may be the wellbore

20 itself. In one aspect of the present invention, the lower bore **32** defines the upper portion of the wellbore.

The bottom plug **280** is disposed in the lower canister **330''** to be released into the wellbore. The bottom plug **280** may be used to clean the drill string or other piping of drilling fluid and to separate the cement from the drilling fluid. Release of the

25 bottom plug **280** is illustrated in **Figure 8B**. To release the bottom plug **280**, the lower plug-retaining valve **340''** is rotated by approximately 90 degrees. Rotation may be in accordance with any of the methods discussed above. The plug-retaining valve **340''** is rotated to align the fluid channel **342** of the lower valve **340''** with the fluid channel **332''** of the lower canister **330''**. In this manner, the plug-retaining valve **340''** is moved from

a plug-retained position to a plug-released position such that the radial surface **344R** of the bottom plug-retaining valve **340''** no longer blocks downward travel of the bottom plug **280**.

5 It should be noted that rotation of the lower valve **340''** to its plug-released position closes off the lower gap **328''**. In this way, fluids cannot continue to flow through the lower canister-housing annulus **322''**, but flow through the channel **342** of the lower valve **340''**. This, in turn, forces fluid flowing from the surface to travel through the lower canister **330''**, thereby forcing the lower dart **280** into the wellbore.

10 The bottom plug **280** travels down the wellbore and wipes the drilling fluid from the drill string with its wipers. In one use, the bottom plug **280** is forced downhole by injection of cement until it contacts a wiper plug (not shown) previously placed in the top of a liner.

15 After the lower plug **280** has been released, the upper plug **180** remains in the upper plug-retaining tool **300'**. It may be desirable to later release the upper plug **180** into the wellbore as well. For example, the upper plug **180** could be used to separate a column of cement from a displacement fluid. Thus, after a sufficient amount of cement is supplied to fill the annular space behind the liner (not shown), the top plug **180** is released behind the cement. In this instance, drilling fluid is pumped in behind the top plug **180**. The top plug **180** separates the two fluids and cleans the drill string or
20 other piping of cement. Release of the upper plug **180** is illustrated in **Figure 8C**.

To release the top plug **180**, the plug-retaining valve **340'** of the upper tubular housing **320'** is rotated by approximately 90 degrees. Rotation again may be in accordance with any of the methods discussed above. Rotation aligns the plug-retaining valve channel **342** of the upper plug retaining valve **340'** with the upper
25 canister channel **332'**, as illustrated in **Figure 8C**. After rotation, the radial surface **344R** of the upper plug-retaining valve **340'** no longer blocks downward travel of the top plug **180**. In this manner, the upper plug-retaining valve **340'** is moved from a plug-retained position to a plug-released position. Rotation of the upper valve **340'** to its plug-released position closes off the upper gap **328'**. In this way, fluids cannot continue

to flow through the upper canister-housing annulus **322'** and into the lower canister **330''**. This, in turn, forces drilling mud or other fluid flowing from the surface to travel through the upper canister **330'**, thereby forcing the upper dart **180** into the wellbore. The top plug **180** then travels through the channel **342** of the upper plug-retaining valve **340'** and continues down through the lower canister channel **332''**, and the channel **342** of the lower plug-retaining valve **340''**. The top plug **180** exits into the lower bore **32** and continues into the wellbore with the drilling mud immediately behind it.

Figure 9A is a cross-sectional view of still another embodiment of a plug-dropping container **400** of the present invention. In this arrangement, the plug-retaining device **440** is a flapper valve. Here, the valve **440** is in its closed position, preventing the downward release of the dart **80**. The canister **430** extends downward below the valve **440**. A lower bypass port **428** is milled into the canister **430** below the valve **440**. The valve **440** preferably contains a curved flapper **444**, having an outer diameter that is dimensioned to match the canister's **430** inner diameter. The flapper **444** mates with a seat **442**. The seat **442** is formed in the canister **430** and serves as the channel for the valve **440**.

The flapper **444** is designed to pivot from a plug-retained position to a plug-released position. To this end, a shaft **447** is provided for rotating the flapper **444**. **Figure 9B** presents a transverse view of the plug-dropping container **400** of **Figure 9A**. The view is taken through **line B-B** of **Figure 9A**. Visible in this view is the flapper **444**, and the shaft **447** for rotating the flapper **444**.

Figure 9C is a cross-sectional view of the plug-dropping container **400** of **Figure 9A**, in its plug-released position. Here, the flapper **444** has been rotated from its plug-retained position against the seat **442** to its plug-released position. It can be seen that the dart **80** is now being released into a wellbore there below. When the flapper **444** is rotated into the plug-released position, the flapper **444** covers the lower bypass port **428**. To this end, the outer surface of the flapper **444** is dimensioned to be received against the lower port **428** for sealing and for diverting fluid through the canister channel **432**.

Figure 9D is a cross-sectional view of the plug-dropping container **400** of **Figure 9C**, with the view taken through **line D-D** of **Figure 9C**. It can be more clearly seen that the flapper **444** has been translated from its plug-retained position to its plug-released position.

5 **Figure 10A** is a cross-sectional view of yet another embodiment of a plug-dropping container **500** of the present invention. In this arrangement, the plug-retaining device **540** is a horizontal plate. Here, the plate **540** is in its closed position, preventing the downward release of the dart **80**.

10 **Figure 10B** presents a transverse view of the plug-dropping container **500** of **Figure 10A**. The view is taken through **line B-B** of **Figure 10A**. Visible in this view is the plate **540**, and a shaft **547** for moving the plate **540** horizontally. It can be seen that the plate **540** has a solid surface **544**, and teeth **548** on at least one side of the solid surface **544**. The teeth **548** interact with at least one gear **549** (seen in **Figure 10A**) for moving the plate **540**. The shaft **547** extends through the housing **520** of the container
15 **500**, permitting the operator to actuate the plate **540**. In this respect, rotation of the shaft **547** imparts rotational movement to the gear **549**. This, in turn, drives the plate **540** between its plug-retained and plug-released positions.

The plate **540** includes a through-opening **542** that serves as the channel for receiving a dart **80**. The through-opening **542** is offset from center. In the plug-retained
20 position for the plate **540**, the through-opening **542** is disposed outside of the longitudinal axis of the canister channel **532**. In this manner, the dart **80** is retained by the solid surface **544** of the plate **540**, and fluid flow through the canister **532** is substantially blocked. At the same time, fluid may travel through the upper bypass ports **536**, through the annular region **522**, around the plate **540**, through a through a lower
25 bypass area **528** below the canister **530**, and then through the channel **32** for the lower head **30**. In this manner, fluid may be injected into the wellbore without releasing the dart **80**. However, when the plate **540** is moved to its plug-released position, the through-opening **542** of the plate **540** is aligned with the canister channel **532**. At the same time, the solid surface **544** of the plate **540** blocks the flow of fluids through the

bypass area **528**. In this manner, fluid urges the dart **80** to be released into the wellbore.

Figure 10C is a cross-sectional view of the plug-dropping container **500** of **Figure 10A**, in its plug-released position. Here, the plate **540** has been translated from its plug-retained position to its plug-released position. It can be seen that the dart **80** is now being released into a wellbore there below.

Figure 10D is a cross-sectional view of the plug-dropping container **500** of **Figure 10C**, with the view taken through **line D-D** of **Figure 10C**. It can be more clearly seen that the plate **540** has been translated from its plug-retained position to its plug-released position.

While the foregoing is directed to embodiments of the present invention, other and further embodiments of the invention may be devised without departing from the basic scope thereof, and the scope thereof is determined by the claims that follow. In this respect, it is within the scope of the present invention to use the plug containers disclosed herein to place plugs for various cleaning and fluid circulation procedures in addition to cementing operations for liners. In addition, the plug-dropping container of the present invention has utility in the context of deploying darts or plugs for the purpose of initiating subsea release of wiper plugs. It is further within the spirit and scope of the present invention to utilize the plug-dropping container disclosed herein for dropping items in addition to drill pipe darts and other plugs. Examples include, but are not limited to, balls and downhole bombs.

Claims:

1. A plug-dropping container within a head member for releasing an object into a wellbore, the plug-dropping container comprising:
 - a tubular housing;
 - 5 a tubular canister disposed within and generally aligned with the tubular housing so as to define an annulus between the tubular housing and the canister, the canister having an inner surface;
 - a channel along the inner surface of the canister, the canister channel being configured to receive the object therein;
 - 10 a valve disposed within the tubular housing proximal to the lower end of canister, the valve having a solid surface, and having a channel through the valve;
 - wherein the valve is movable from an object-retained position to an object-released position such that (1) in its object-retained position, the solid surface of the valve substantially blocks the object from exiting the canister, but fluids are permitted to
15 flow around the valve, and (2) in its object-released position, the channel of the valve is in substantial alignment with the channel of the canister thereby permitting the object to exit the canister and to travel downward through the channel of the valve, and the solid surface of the valve substantially blocks the flow of fluid around the valve.
- 20 2. The plug-dropping container of claim 1, wherein the object is a plug.
3. The plug-dropping container of claim 2, wherein the plug is a dart.
4. The plug-dropping container of claim 1, wherein the object is a ball.
- 25 5. The plug-dropping container of claim 1, wherein the object is a bomb.
6. The plug-dropping container of claim 1, wherein the tubular housing comprises a top opening and a bottom opening, and wherein the housing is in fluid communication
30 with a channel in the head member through which fluids are circulated into the wellbore.

7. The plug-dropping container of claim 6, wherein the canister further comprises:
a top opening;
a bottom opening; and
a bypass area for placing the inner surface of the canister in fluid communication
5 with the annulus between the housing and the canister.
8. The plug-dropping container of claim 7, wherein the bypass defines at least one
port disposed in the canister.
- 10 9. The plug dropping container of claim 7, wherein the bypass defines a gap
between the top opening of the canister and the head member.
10. The plug-dropping container of claim 1, wherein:
the solid surface of the valve defines a radial surface; and
15 the valve has a truncated portion so as to disrupt the radial surface around the
valve channel, thus providing a means for bypass flow past the valve when the valve is
in its object-retained position.
11. The plug-dropping container of claim 10, wherein the radial surface of the valve
20 is rotated into close proximity with a lower opening in the canister so that it blocks
release of the object when the valve is in its object-retained position.
12. The plug-dropping container of 11, wherein the valve is spherical in shape.
- 25 13. The plug-dropping container of claim 10, wherein the valve is cylindrical in shape.
14. The plug-dropping container of claims 12 and 13, further comprising a stop
member for limiting rotation of the valve to approximately 90 degrees.
- 30 15. The plug-dropping container of claim 14, wherein rotation of the retaining valve is
via a shaft.

16. The plug-dropping container of claim 15, wherein rotation of the valve is accomplished manually.
17. The plug-dropping container of claim 15, wherein rotation of the valve is power
5 driven.
18. The plug-dropping container of 1, wherein the valve defines a plate.
19. The plug-dropping container of 18, wherein the plate comprises:
10 a solid portion as the solid surface; and
a through-opening offset from the solid portion to serve as the channel.
20. The plug-dropping container of 19, wherein the plate further comprises:
teeth along at least one side of the plate for interacting with a gear;
15
21. The plug-dropping container of 1, wherein the valve defines a flapper valve.
22. The plug-dropping container of 21, wherein:
the flapper valve comprises a solid curved flapper to serve as the solid surface,
20 and a seat to serve as the channel;
the canister comprises a lower bypass port positioned below the flapper valve;
and
the flapper valve further comprises a shaft for rotating the flapper from (1) an
object-retained position such that the flapper blocks the downward release of the object
25 from the canister to an object-released position but permits fluid to flow from the
annulus, around the flapper, and through the lower bypass port, to (2) an object-
released position such that the flapper substantially seals the lower bypass port and the
seat receives the object.
- 30 23. The plug-dropping container of claim 7, wherein the head member is a cementing
head.

24. The plug-dropping container of claim 7, further comprising at least one spacer disposed between the housing and the canister for essentially centralizing the canister within the housing.

5 25. A plug-dropping container for dispensing plugs into a wellbore during a cementing operation, the plug-dropping container being connected to a cementing head having a fluid flow channel therein for receiving fluids, the plug-dropping container, comprising:

10 a tubular housing having a top opening and a bottom opening, the housing being in fluid communication with the bore in the cementing head;

an upper canister disposed within and generally aligned with the housing so as to define an upper annulus between the tubular housing and the upper canister, the upper canister also having a top opening and a bottom opening;

15 a channel within the upper canister, the channel of the upper canister being configured to receive a top plug therein;

an upper bypass proximate to the top opening of the upper canister for permitting fluid to flow into the upper annulus;

20 an upper plug-retaining valve disposed within the housing proximal to the bottom opening of the upper canister, the upper plug-retaining valve having a solid surface, and having a channel through the valve;

a lower canister disposed within and generally aligned with the housing and below the upper plug-retaining valve so as to define a lower annulus between the housing and the lower canister, the lower canister also having a top opening and a bottom opening;

25 a channel within the lower canister, the channel of the lower canister being configured to receive a bottom plug therein;

a lower bypass proximate to the top opening of the lower canister for permitting fluid to flow into the lower annulus;

30 a lower plug-retaining valve disposed within the housing below the bottom opening of the lower canister, the lower plug-retaining valve having a solid surface, and having a channel through the valve;

wherein the lower plug-retaining valve is movable from a plug-retained position to a plug-released position such that (1) in its plug-retained position, the solid surface of the lower valve substantially blocks the plug from exiting the lower canister, but fluids are permitted to flow around the lower valve, and (2) in its plug-released position, the channel of the lower valve is in substantial alignment with the channel of the lower canister thereby permitting the plug to exit the lower canister and to travel downward through the channel of the lower valve, and the solid surface of the valve substantially blocks the flow of fluid around the valve; and

wherein the upper plug-retaining valve is movable from a plug-retained position to a plug-released position such that (1) in its plug-retained position, the solid surface of the upper valve substantially blocks the plug bottom from exiting the lower canister, but fluids are permitted to flow around the lower valve, and (2) in its plug-released position, the channel of the upper valve is in substantial alignment with the channel of the upper canister thereby permitting the plug to exit the upper canister and to travel downward through the channel of the upper valve, and the solid surface of the valve substantially blocks the flow of fluid around the valve.

26. The plug-dropping container of claim 25, wherein the plug is a dart.

27. The plug-dropping container of claim 26, wherein each of the upper and lower canisters further comprises:

a top opening;

a bottom opening; and

a bypass area for placing the inner surface of the respective canister in fluid communication with the annulus between the housing and the canister.

28. The plug-dropping container of claim 27, wherein the bypass area defines at least one port disposed in the canister.

29. The plug dropping container of claim 27, wherein the bypass area defines a gap between the top opening of the respective canister and the cementing head.

30. The plug-dropping container of claim 25, wherein:
the solid surface of the upper and lower valves defines a radial surface; and
each of the valves has a truncated portion so as to disrupt the radial surface
around the respective valve channels, thus providing a means for bypass flow past the
5 valves when the valves are in their respective plug-retained positions.
31. The plug-dropping container of claim 30, wherein the radial surfaces of the
respective valves is rotated into close proximity with a lower opening in the upper and
lower canisters, respectively, so as to block release of the upper and lower plugs when
10 the upper and lower valves are in their respective plug-retained positions.
32. The plug-dropping container of 31, wherein the upper and lower valves are each
spherical in shape.
- 15 33. The plug-dropping container of claim 31, wherein the upper and lower valves are
each cylindrical in shape.
34. The plug-dropping container of claims 32 and 33, further comprising upper and
lower stop members for limiting rotation of the upper and lower valves, respectively, to
20 approximately 90 degrees.
35. The plug-dropping container of 25, wherein at least one of the upper and lower
valves defines a plate.
- 25 36. The plug-dropping container of 35, wherein the plate comprises:
a solid portion as the solid surface; and
a through-opening offset from the solid portion to serve as the channel.
37. The plug-dropping container of 36, wherein the plate further comprises:
30 teeth along at least one side of the plate for interacting with a gear;

38. The plug-dropping container of 25, wherein the at least one of the upper and lower valves defines a flapper valve.

39. The plug-dropping container of 38, wherein:

5 the flapper valve comprises a solid curved flapper to serve as the solid surface, and a seat to serve as the channel;

the canister comprises a lower bypass port positioned below the flapper valve; and

10 the flapper valve further comprises a shaft for rotating the flapper from (1) an object-retained position such that the flapper blocks the downward release of the object from the canister to an object-released position but permits fluid to flow from the annulus, around the flapper, and through the lower bypass port, to (2) an object-released position such that the flapper substantially seals the lower bypass port and the seat receives the plug.

15

40. A plug-dropping container within a head member for releasing an object into a wellbore, the plug-dropping container comprising:

a tubular housing;

20 a tubular canister disposed within and generally aligned with the tubular housing so as to define an annulus between the tubular housing and the canister, the canister having an inner surface;

a channel along the inner surface of the canister, the canister channel being configured to receive the object therein;

25 a valve disposed within the tubular housing proximal to the lower end of canister, the valve having a solid radial surface, and having a channel through the valve;

30 wherein the valve is rotatable from an object-retained position to an object-released position such that (1) in its object-retained position, the radial surface of the valve substantially blocks the object from exiting the canister, and (2) in its object-released position, the channel of the valve is in substantial alignment with the channel of the canister thereby permitting the object to exit the canister and to travel downward through the channel of the valve, and wherein the radial surface around a perimeter of

one end of the valve channel is placed in close proximity with the lower channel of the head member where it substantially blocks the flow in the annulus between the tubular housing and the canister in the object-released position.

5 41. The plug-dropping container of 40, wherein the valve is spherical in shape.

42. The plug-dropping container of 40, wherein the valve further comprises a bypass region which allows fluid to flow from the housing annulus to the lower channel of the head member when the valve is in its object-retained position.

10

43. The plug-dropping container of claim 42, wherein the valve bypass region comprises a truncated portion of the radial surface.

15

44. The plug-dropping container of claim 42, wherein the valve bypass region comprises at least one opening through the radial surface.

44. The plug-dropping container of claim 40, wherein the valve is cylindrical in shape.

20

45. The plug-dropping container of claim 40, further comprising a stop member for limiting rotation of the valve to approximately 90 degrees.

46. A plug-dropping container within a head member for releasing an object into a wellbore, the plug-dropping container comprising:

a tubular housing;

25

a tubular canister disposed within and generally aligned with the tubular housing so as to define an annulus between the tubular housing and the canister, the canister having an inner surface;

a channel along the inner surface of the canister, the canister channel being configured to receive the object therein;

a valve disposed within the tubular housing proximal to the lower end of canister, the valve defining a plate comprising a solid surface and a channel offset from the solid surface;

5 wherein the valve is movable from an object-retained position to an object-released position such that (1) in its object-retained position, the solid surface of the valve blocks the object from exiting the canister, and (2) in its object-released position, the channel of the valve is in substantial alignment with the channel of the canister thereby permitting the object to exit the canister and to travel downward through the channel of the valve.

10

47. The plug-dropping container of claim 46, wherein fluids are permitted to flow from the housing annulus, around the plate, to the lower channel of the head member when the valve is in its object-retained position, but such flow is substantially blocked by the solid surface of the plate when the plate is in its object-retained position.

15

48. The plug-dropping container of claim 46, wherein fluids are permitted to flow from the housing annulus, through at least one channel in the plate, to the lower channel of the head member when the valve is in its object-retained position, but such flow is substantially blocked by the solid surface of the plate when the plate is in its object-

20

49. The plug-dropping container of claim 45, wherein the plate further comprises: teeth along at least one side of the plate for interacting with a gear.

25 50. A plug-dropping container within a head member for releasing an object into a wellbore, the plug-dropping container comprising:

a tubular housing;

a tubular canister disposed within and generally aligned with the tubular housing so as to define an annulus between the tubular housing and the canister, the canister

30

having an inner surface and a lower bypass port;

a channel along the inner surface of the canister, the canister channel being configured to receive the object therein;

5 a flapper valve disposed within the tubular housing proximal to the lower end of the canister but above the lower bypass port, the flapper valve comprising a solid curved flapper, a shaft for rotating the flapper, and a seat to serve as the channel;

10 wherein the shaft is rotatable to move the flapper valve from an object-retained position to an object-released position such that (1) in its object-retained position, the curved flapper of the valve substantially blocks the object from exiting the canister, but fluids are permitted to flow around the flapper and through the lower bypass port, and (2) in its object-released position, the flapper moves to permit the object to exit the canister and to travel downward through the seat, and substantially seals the lower bypass port.

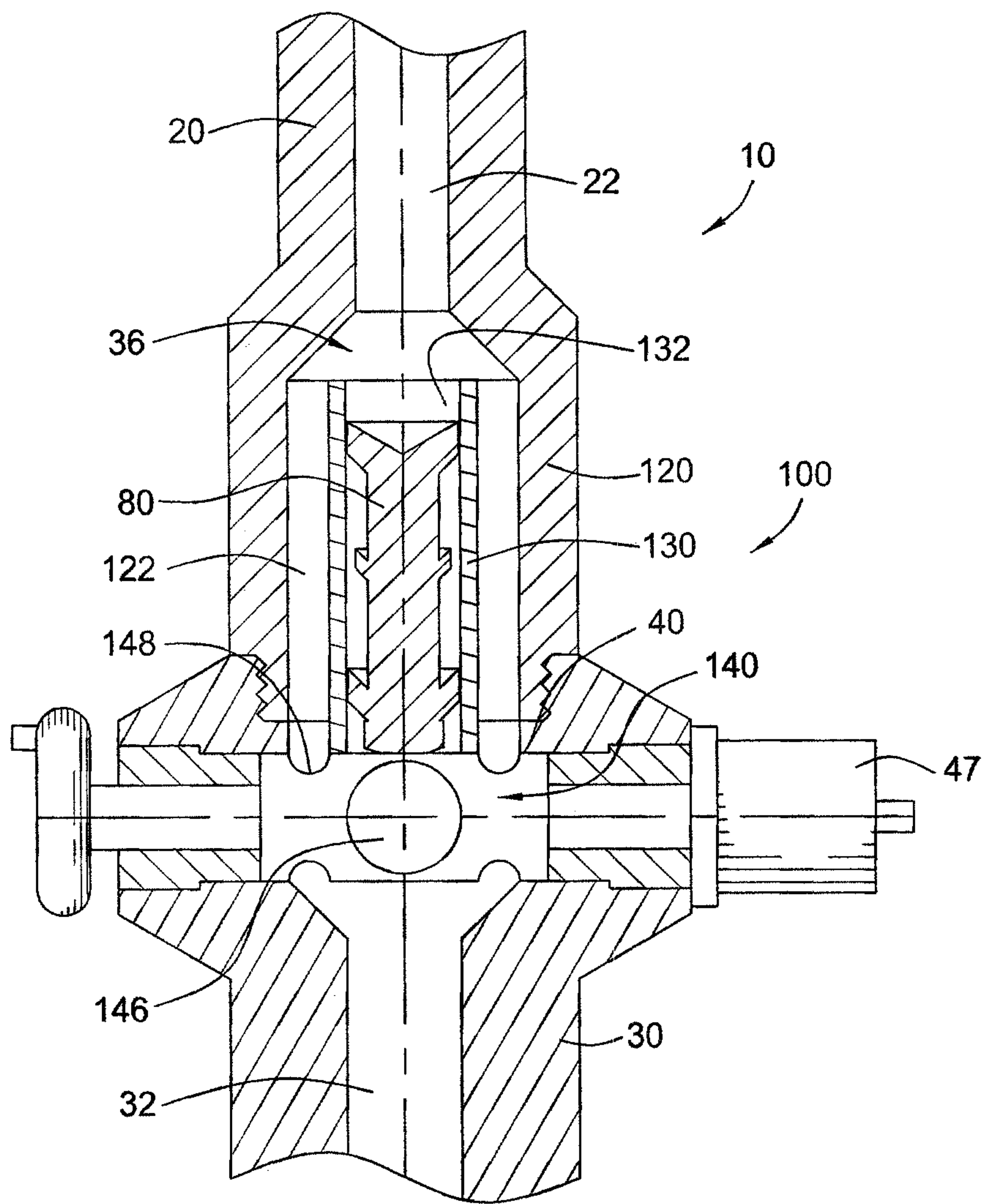

FIG. 1

2/13

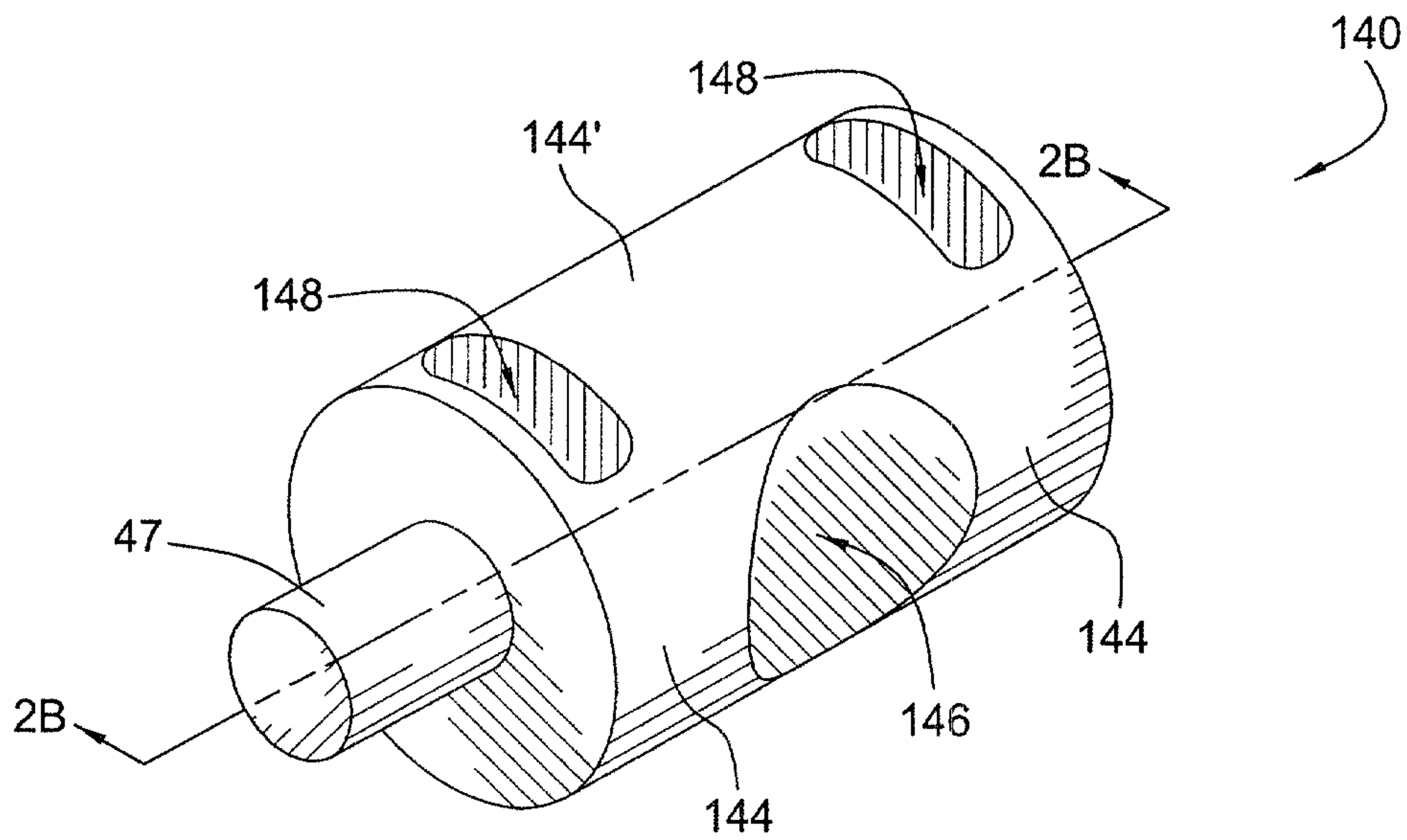

FIG. 2A

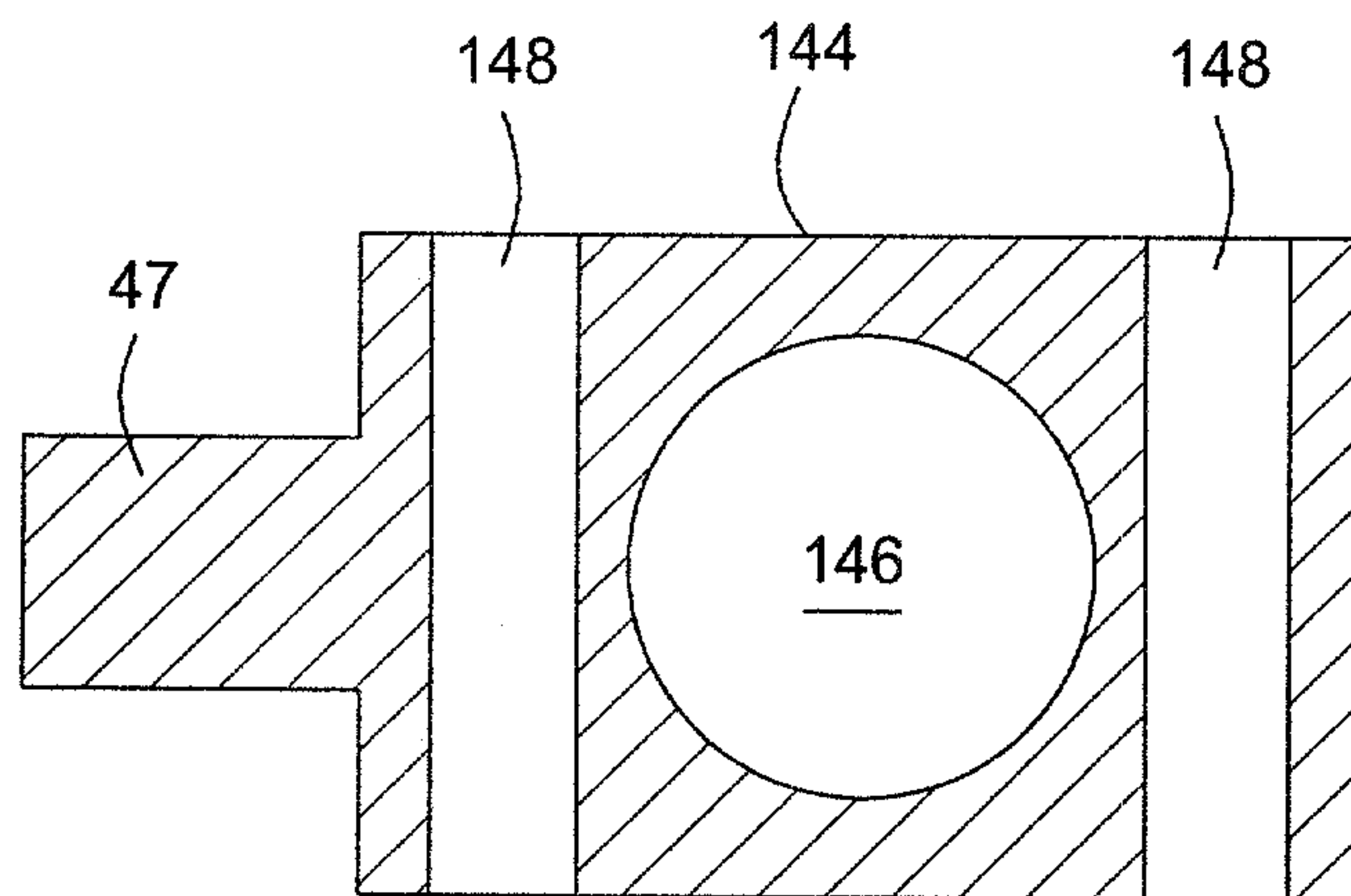
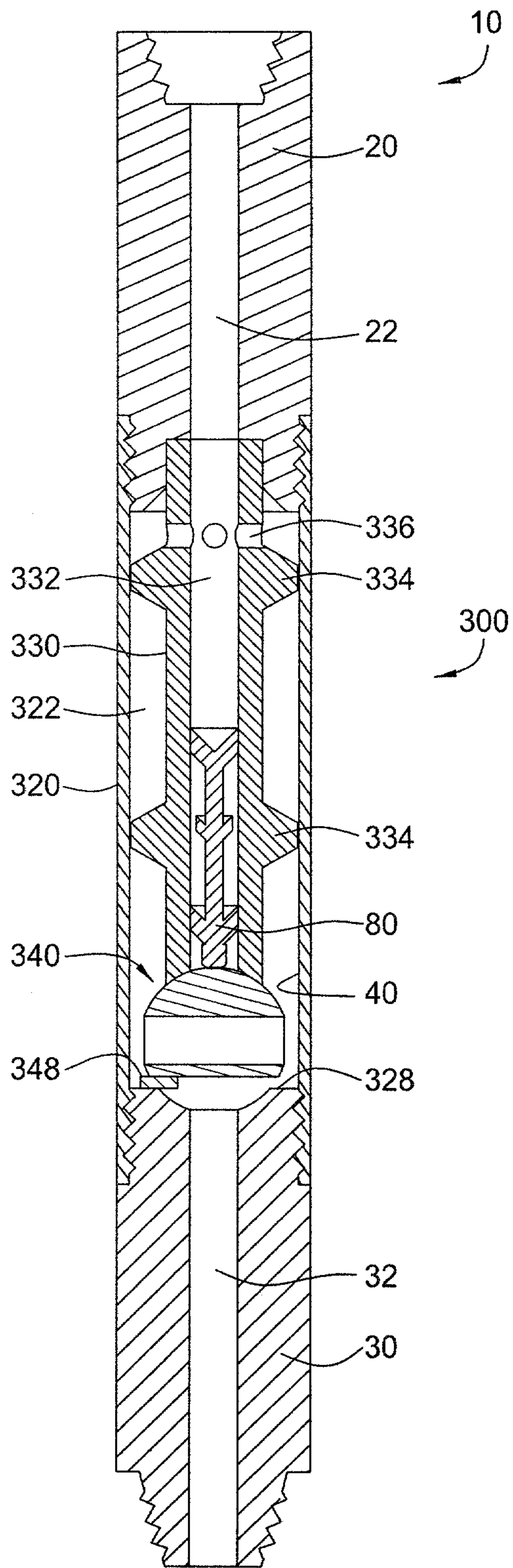

FIG. 2B

FIG. 3



4/13

FIG. 4

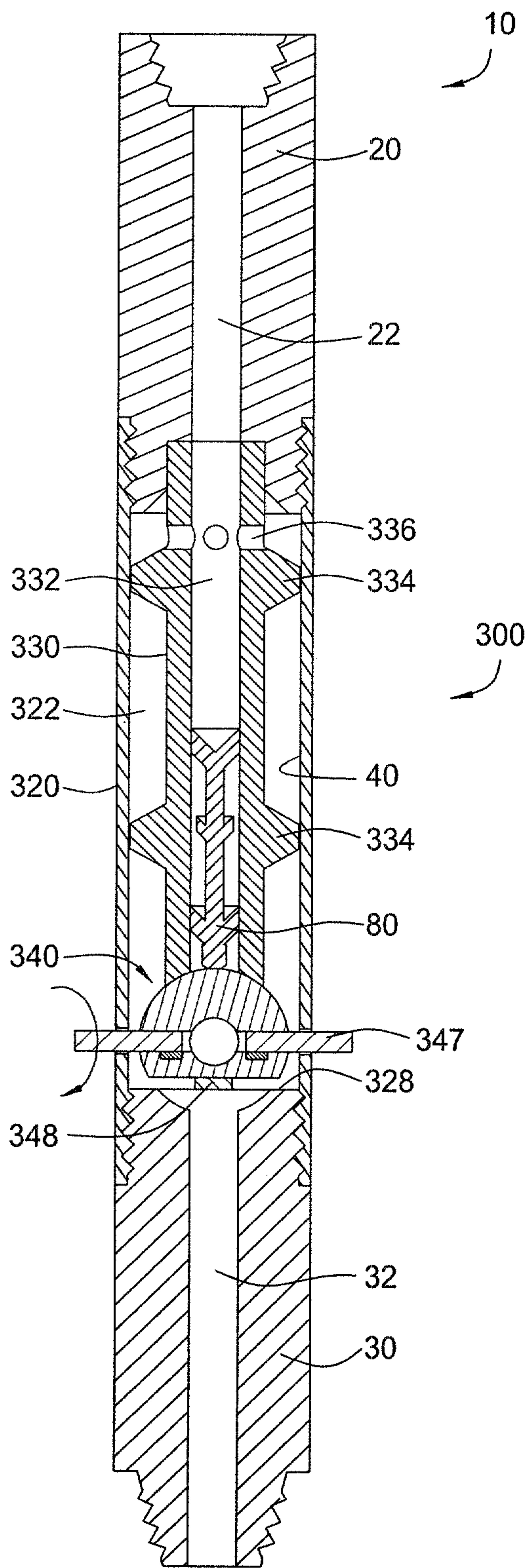

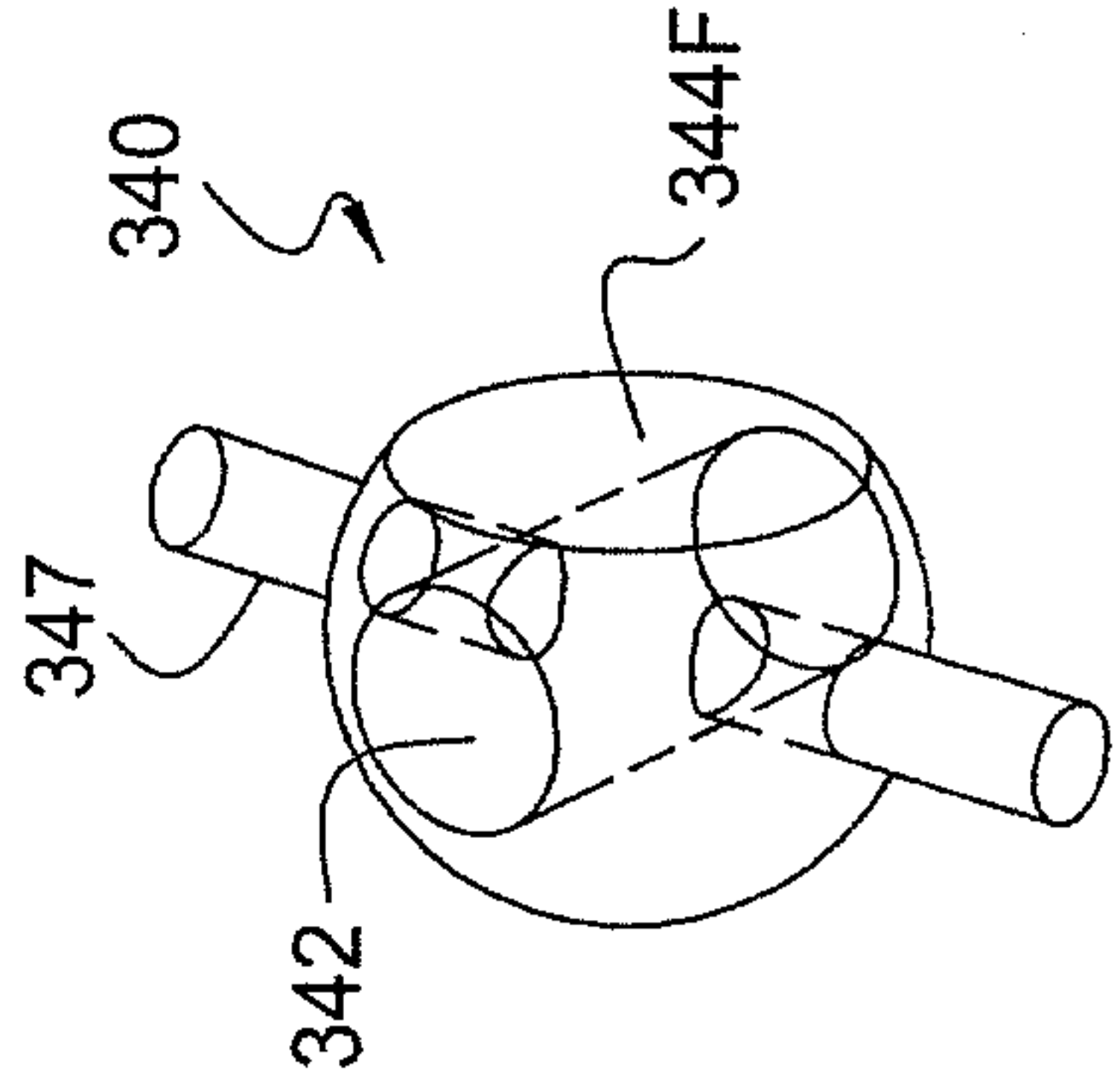

FIG. 5C

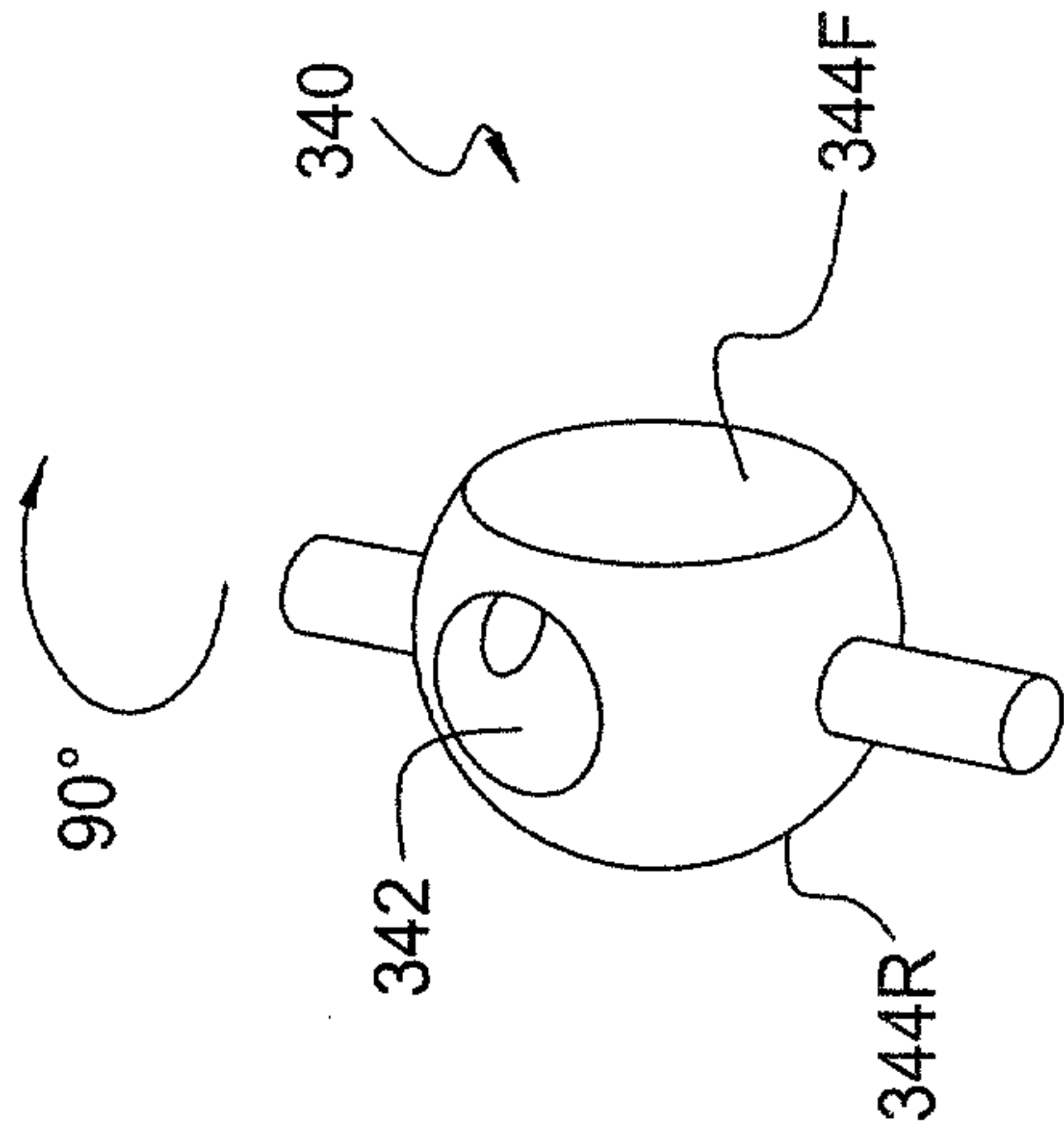

FIG. 5B

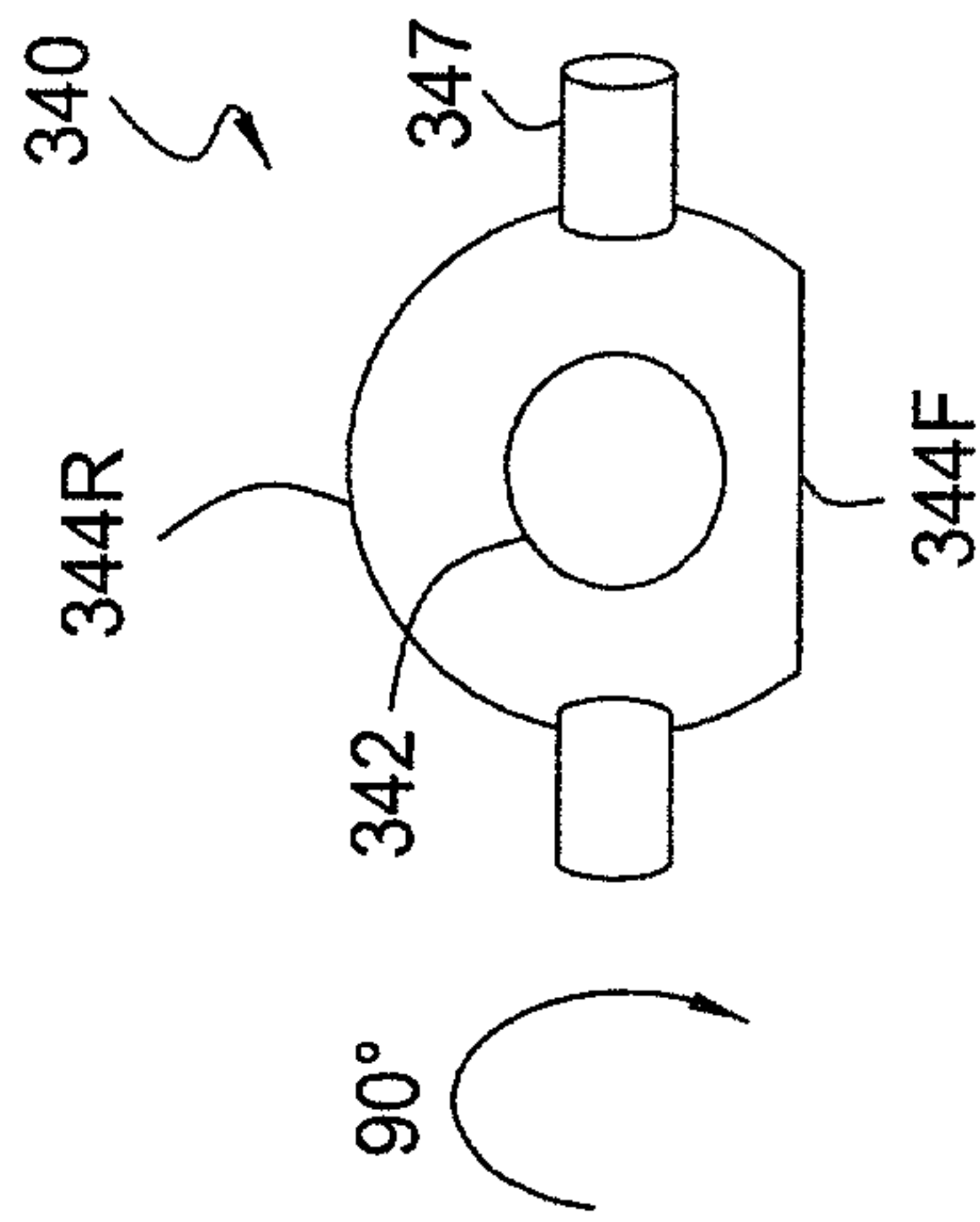

FIG. 5A

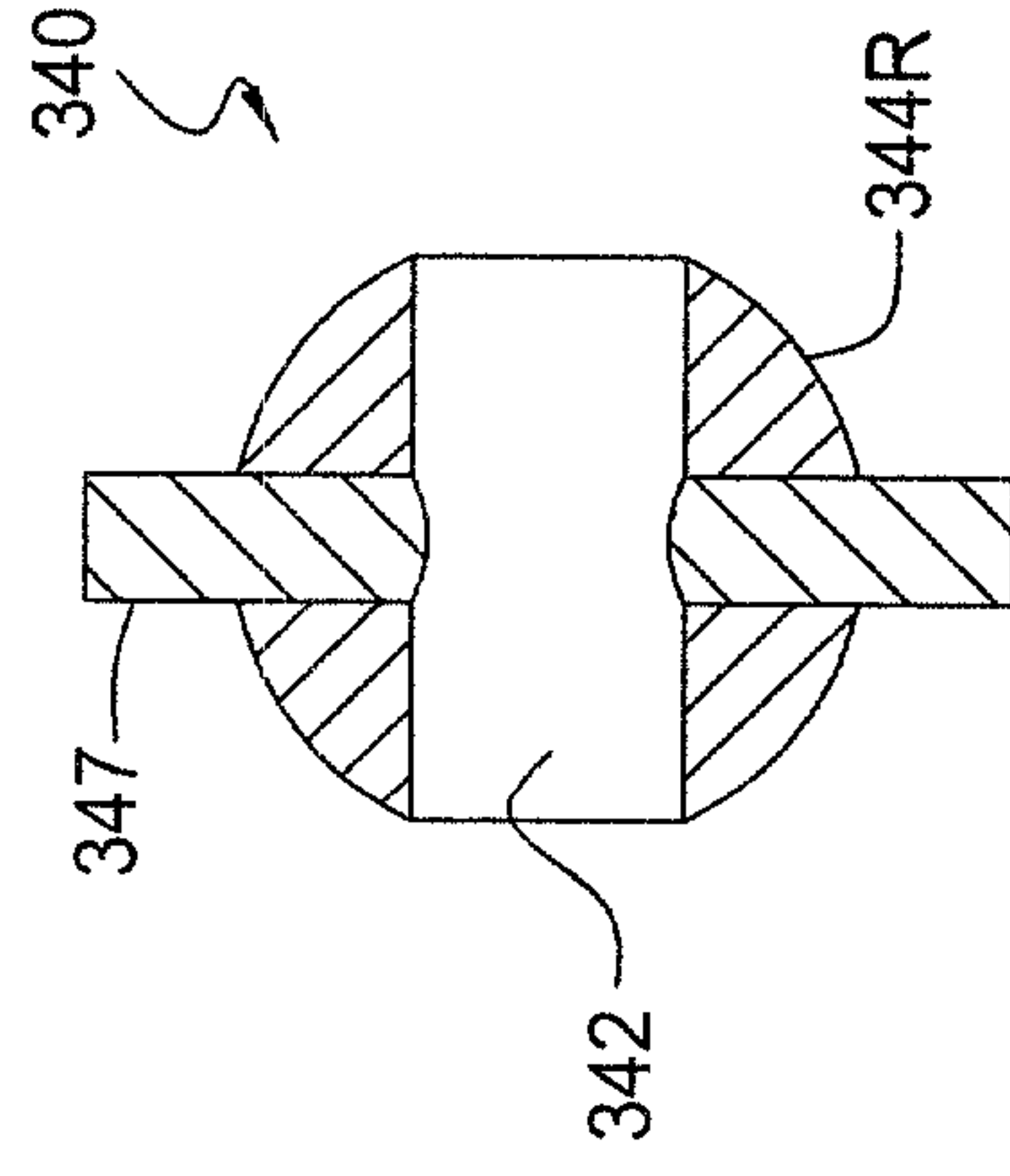

FIG. 5F

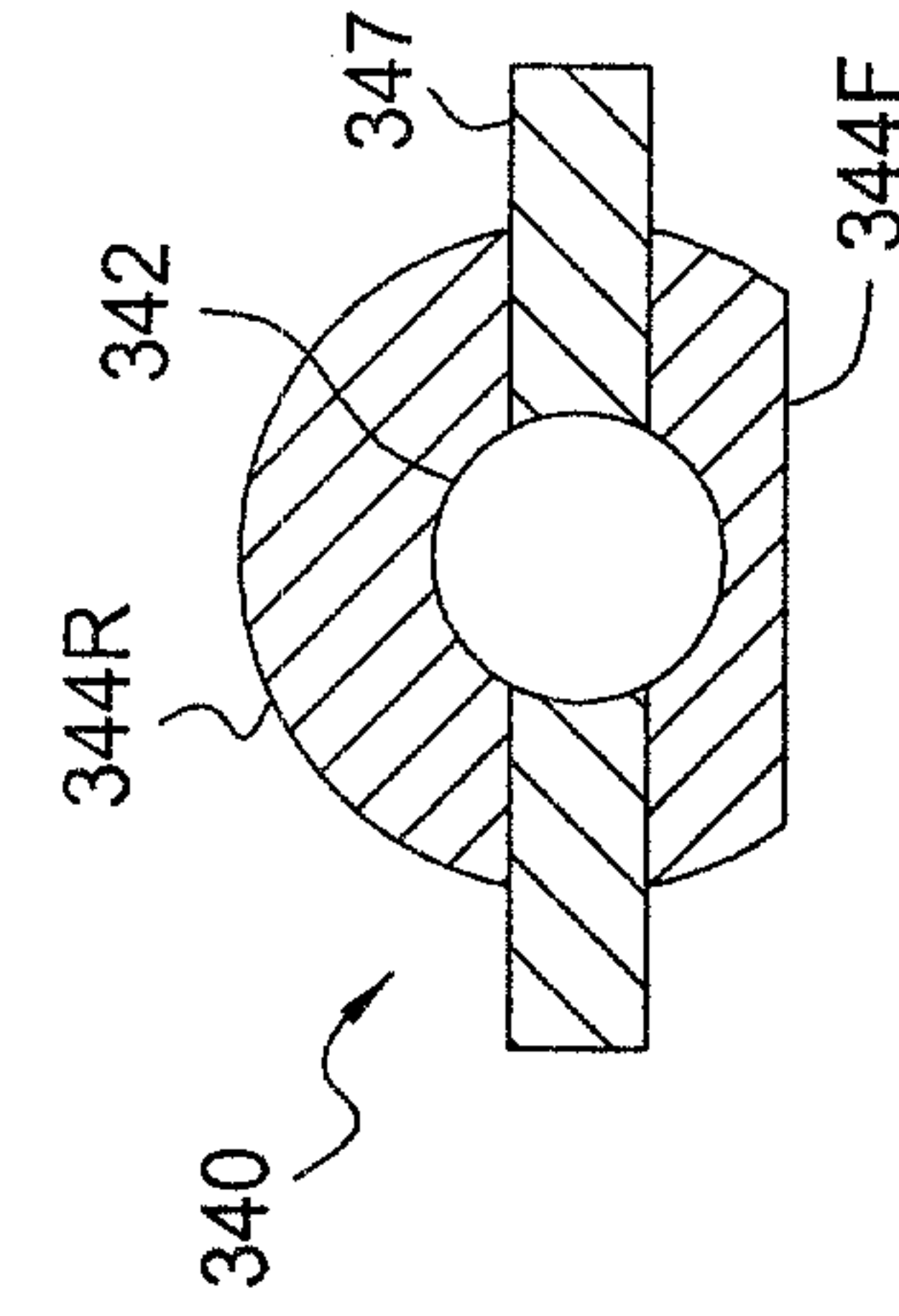

FIG. 5E

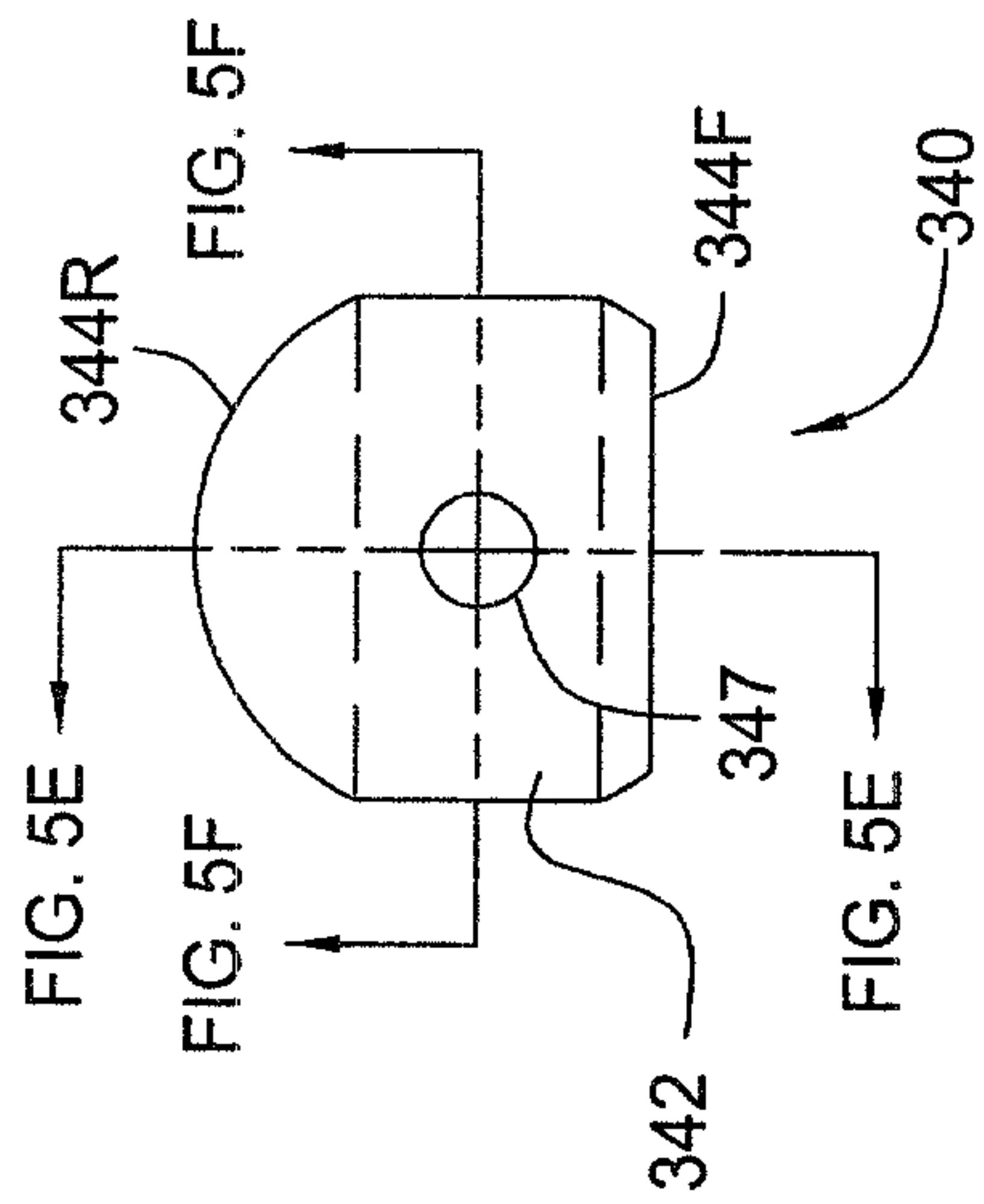
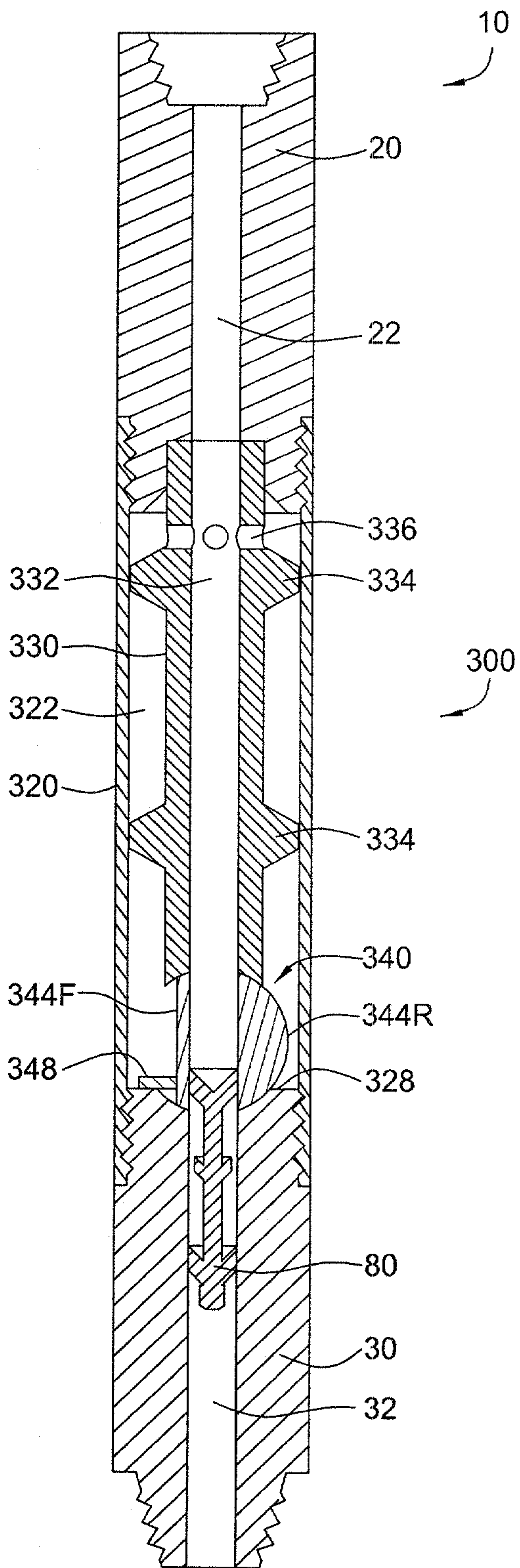

FIG. 5D

6/13

FIG. 6



7/13

FIG. 7

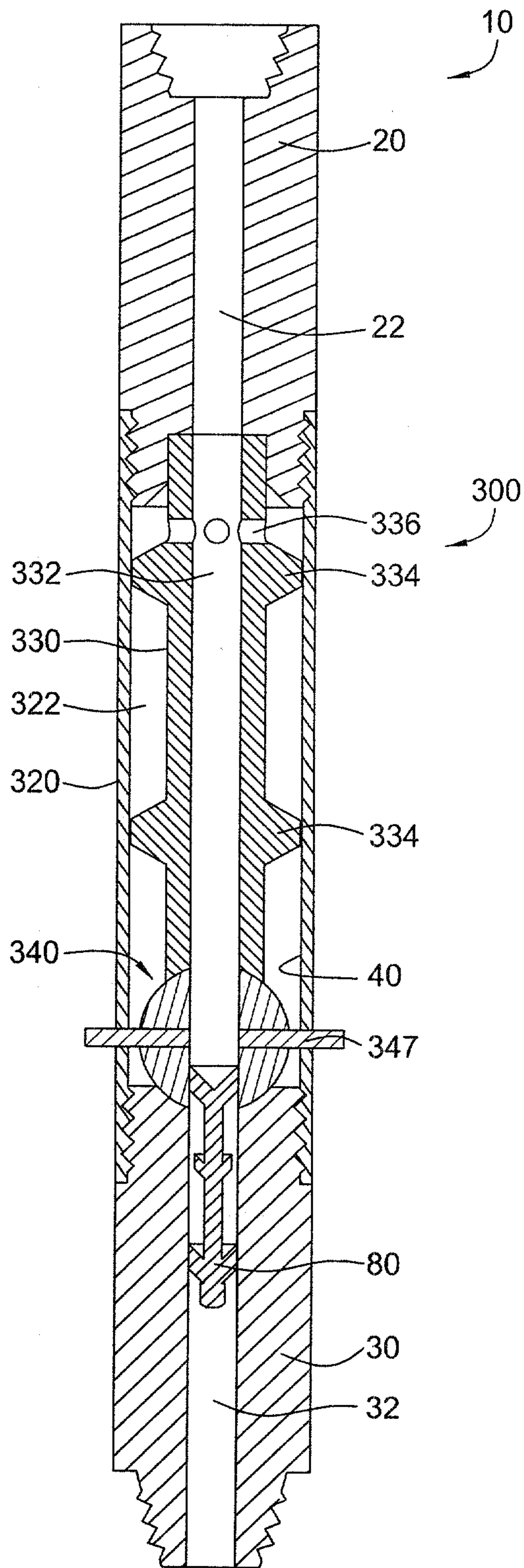

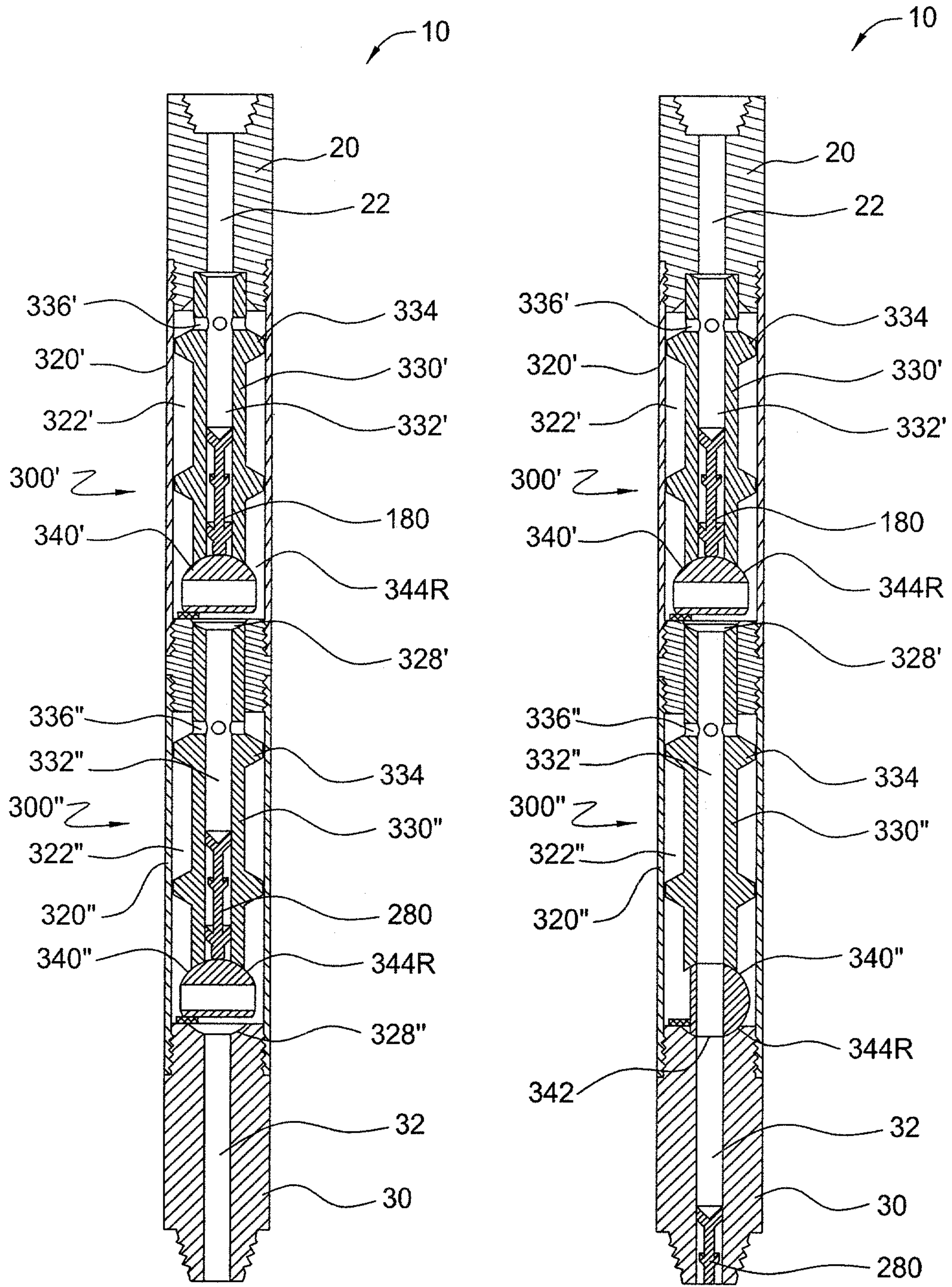

FIG. 8A

FIG. 8B

9/13

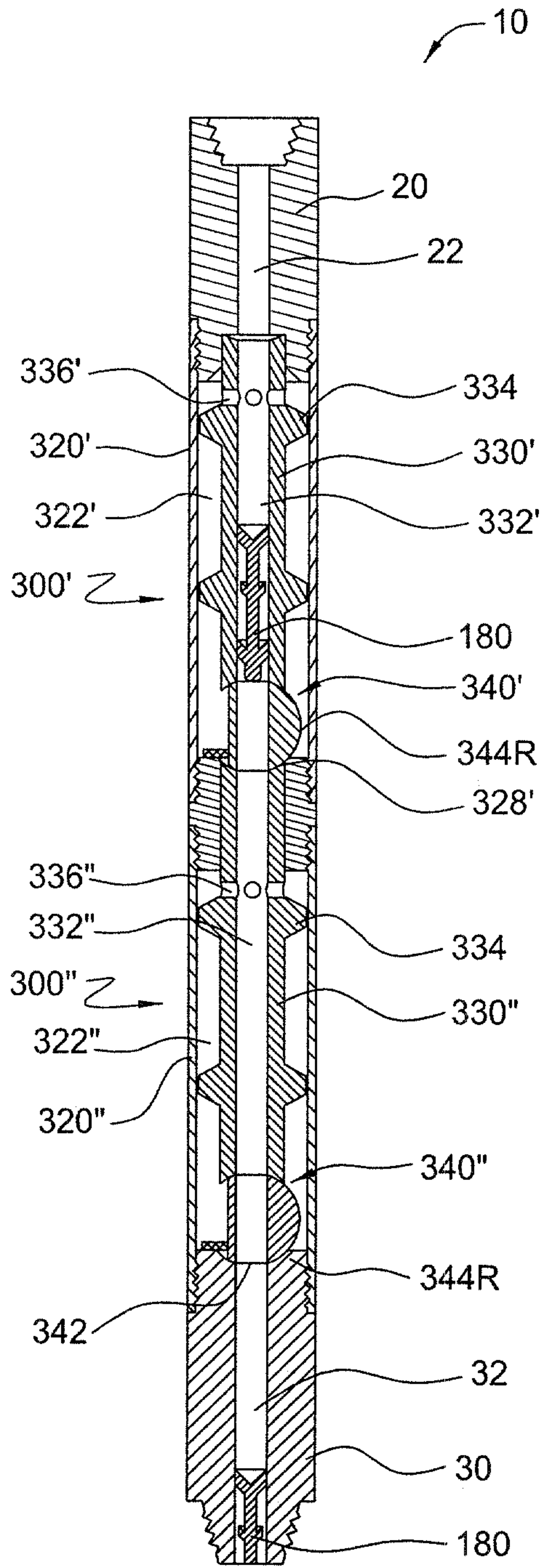

FIG. 8C

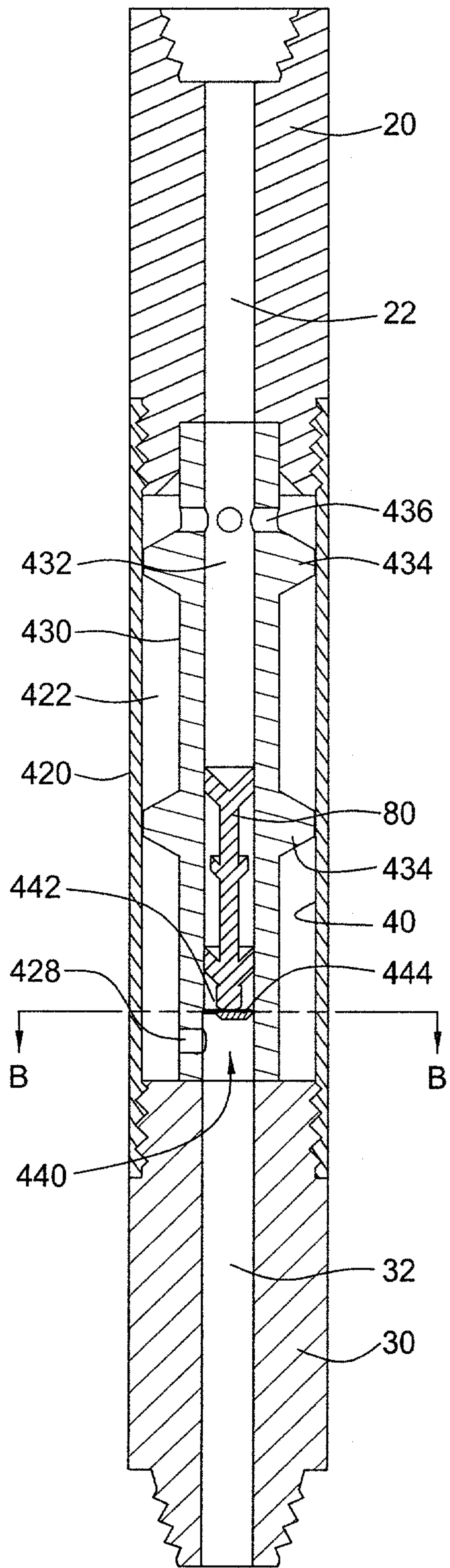

FIG. 9A

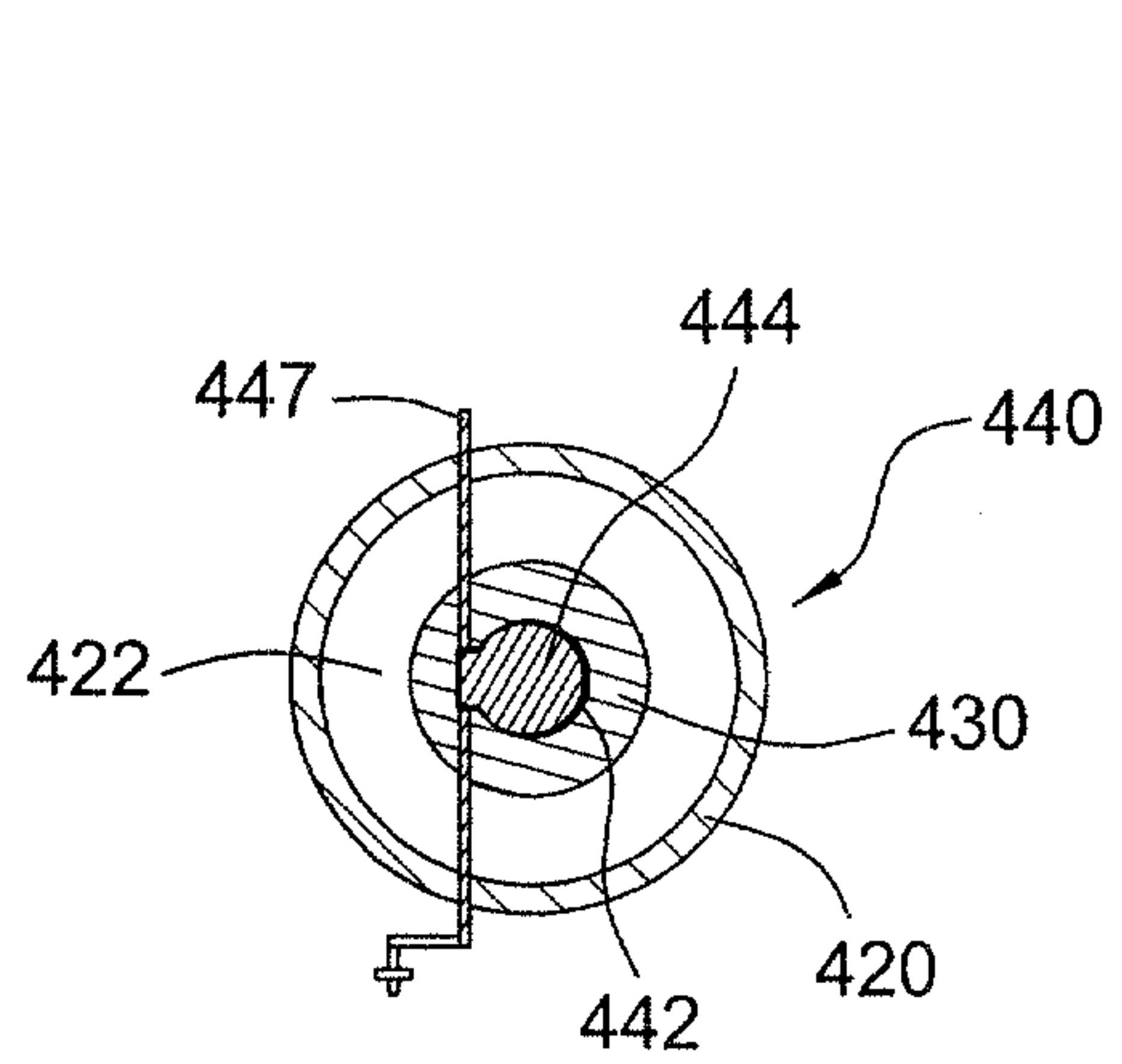

FIG. 9B

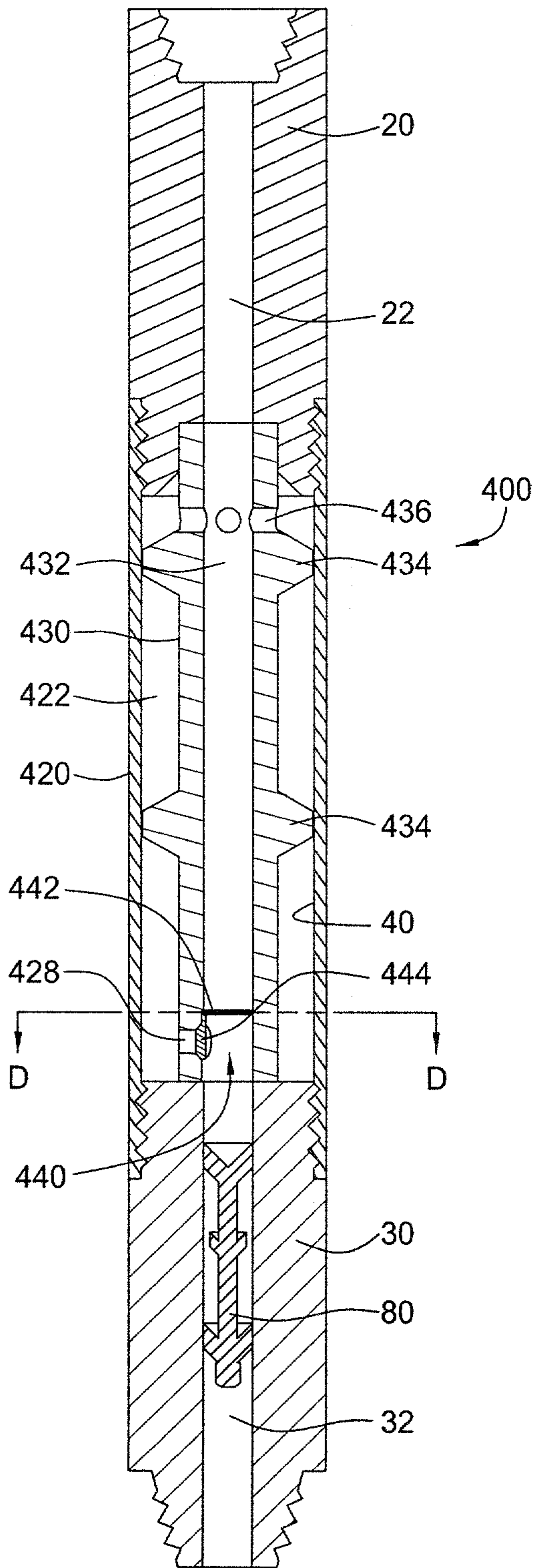

FIG. 9C

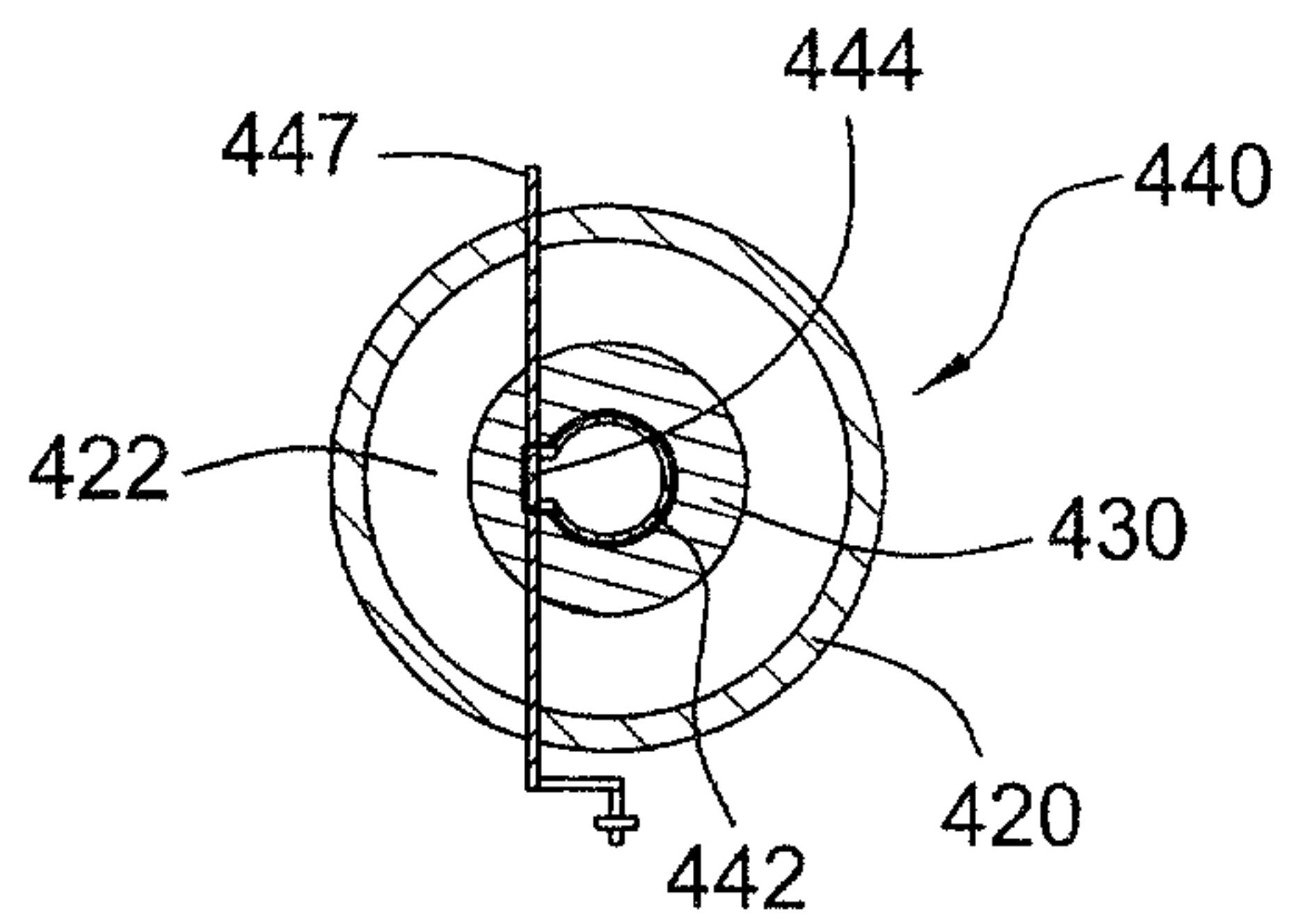

FIG. 9D

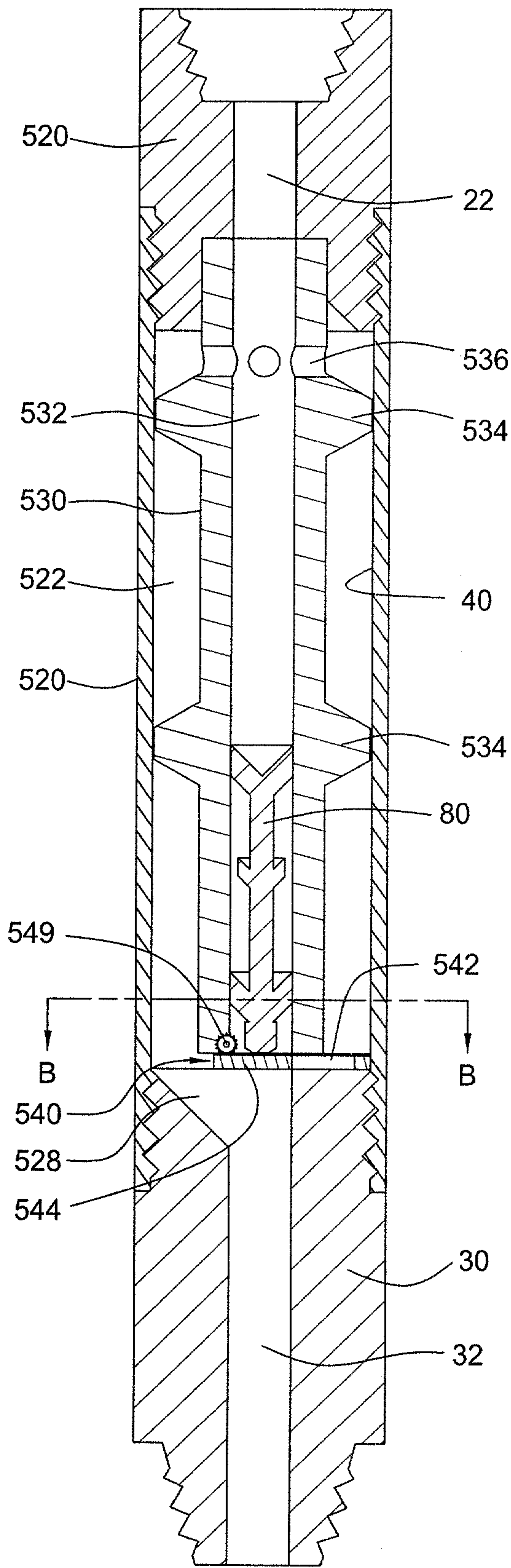

FIG. 10A

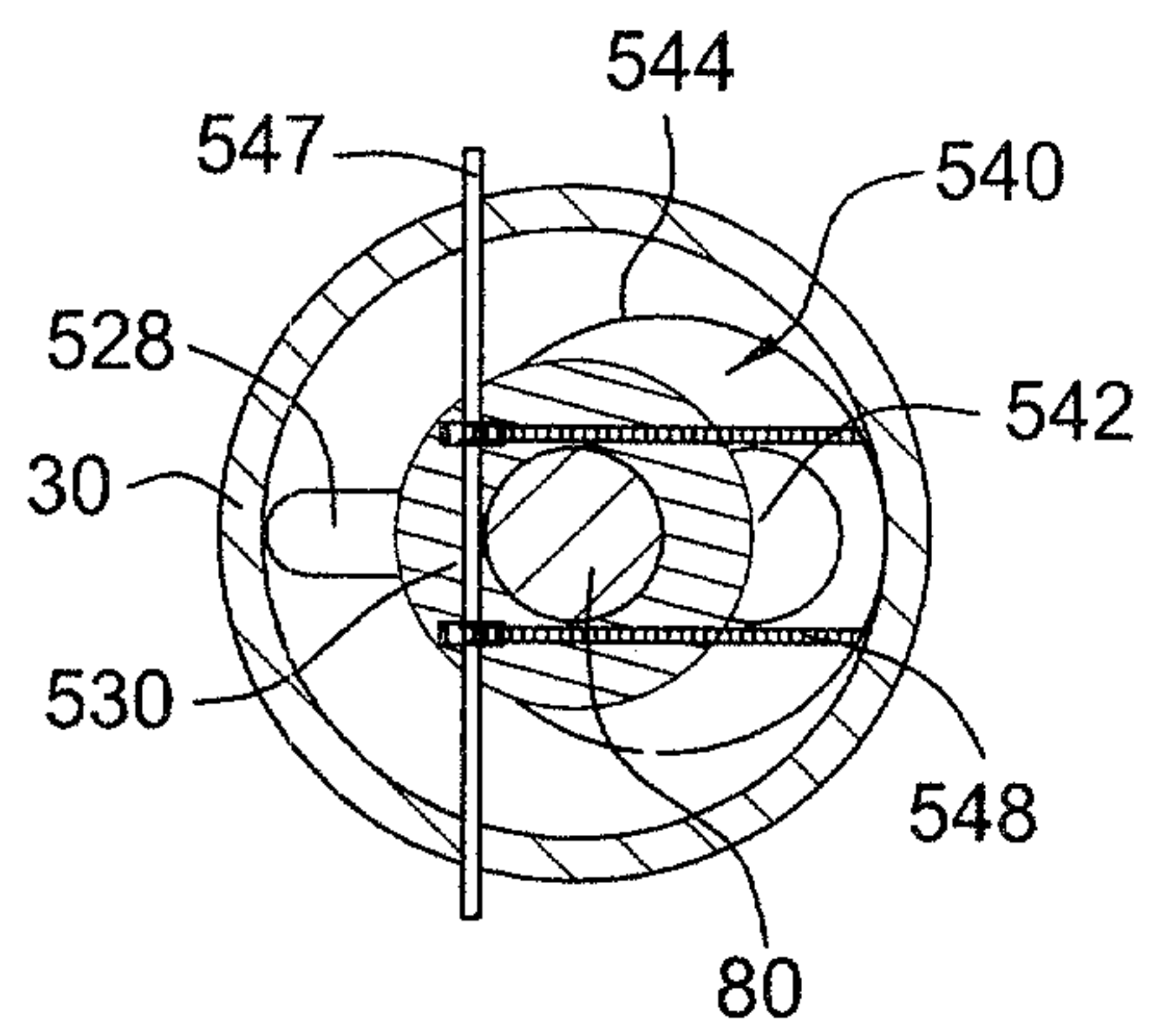

FIG. 10B

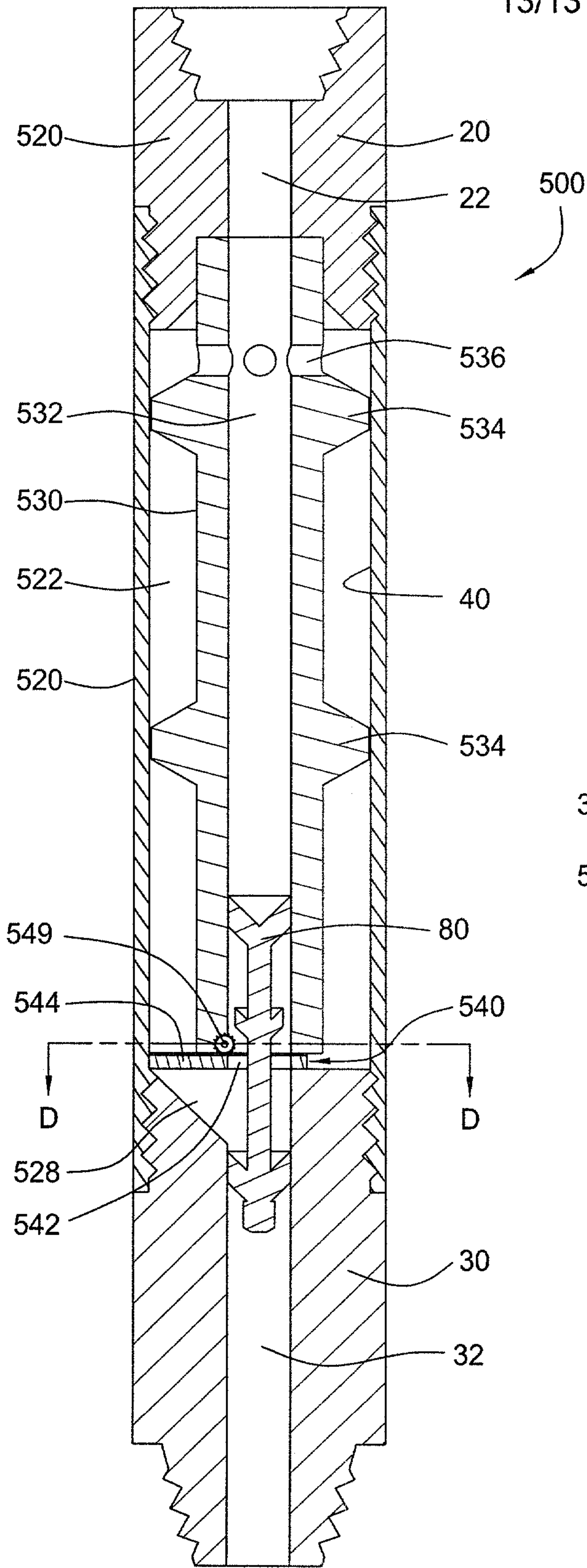

FIG. 10C

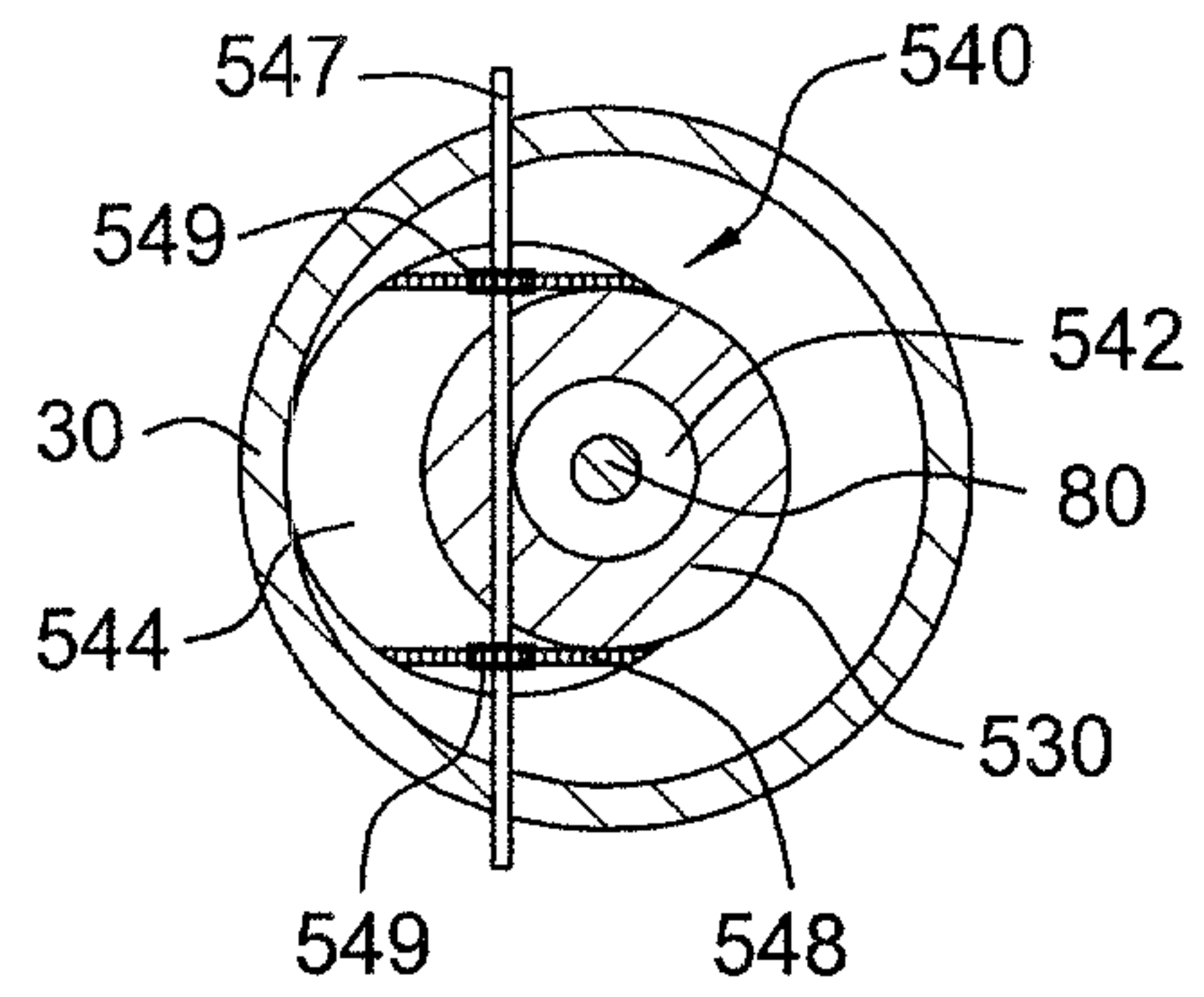

FIG. 10D

