



(12) **United States Design Patent**
Majdandzic

(10) **Patent No.:** **US D625,674 S**
(45) **Date of Patent:** **** Oct. 19, 2010**

- (54) **SIDE MIRROR FOR A VEHICLE**
- (75) Inventor: **Mario Majdandzic**, Munich (DE)
- (73) Assignee: **Bayerisch Motoren Werke Aktiengesellschaft**, Munich (DE)
- (**) Term: **14 Years**
- (21) Appl. No.: **29/356,057**
- (22) Filed: **Feb. 19, 2010**

- (30) **Foreign Application Priority Data**
Aug. 20, 2009 (DE) 402009004134
- (51) **LOC (9) Cl.** **12-16**
- (52) **U.S. Cl.** **D12/187**
- (58) **Field of Classification Search** D12/187,
D12/188-189; D6/300, 309; 359/838, 841,
359/842, 843, 844, 868, 871, 604, 881, 514,
359/866; 248/479-483, 475.1
See application file for complete search history.

- (56) **References Cited**
U.S. PATENT DOCUMENTS
D506,169 S * 6/2005 Pfeiffer et al. D12/187
6,929,300 B1 * 8/2005 Kuo 296/1.11
D519,071 S * 4/2006 Moruzzi D12/187
D612,311 S * 3/2010 Weil D12/187
2002/0021509 A1 * 2/2002 Foote et al. 359/877
2005/0200987 A1 * 9/2005 Pavao 359/871
2006/0050423 A1 * 3/2006 Secanu et al. 359/871
2009/0015955 A1 * 1/2009 Muller 359/871
2009/0103198 A1 * 4/2009 Chuang 359/872

* cited by examiner

Primary Examiner—Caron Veynar
Assistant Examiner—Katrina A Kile
(74) *Attorney, Agent, or Firm*—Crowell & Moring LLP

(57) **CLAIM**

The ornamental design for a side mirror for a vehicle, as shown and described.

DESCRIPTION

FIG. 1 is a left, rear perspective view of a first embodiment of a side mirror for a vehicle according to my design;
 FIG. 2 is a right, front perspective view thereof;
 FIG. 3 is a front perspective view thereof;
 FIG. 4 is a rear perspective view thereof;
 FIG. 5 is a rear view thereof;
 FIG. 6 is a front view thereof;
 FIG. 7 is a top view thereof; and,
 FIG. 8 is a bottom view thereof.
 FIG. 9 is a right, rear perspective view of a second embodiment of the side mirror for a vehicle according to my design;
 FIG. 10 is a left, front perspective view thereof;
 FIG. 11 is a front perspective view thereof;
 FIG. 12 is a rear perspective view thereof;
 FIG. 13 is a rear view thereof;
 FIG. 14 is a front view thereof;
 FIG. 15 is a top view thereof; and,
 FIG. 16 is a bottom view thereof.

In the drawings, the broken lines show bolt holes only and form no part of the claimed design.

1 Claim, 6 Drawing Sheets

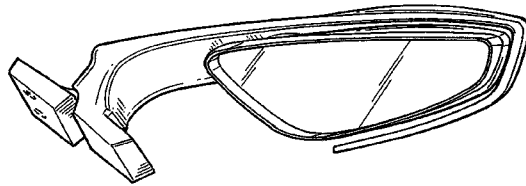
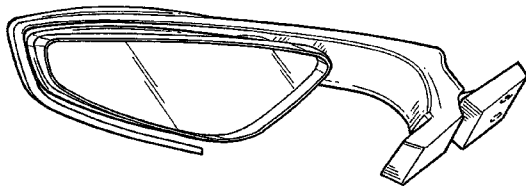

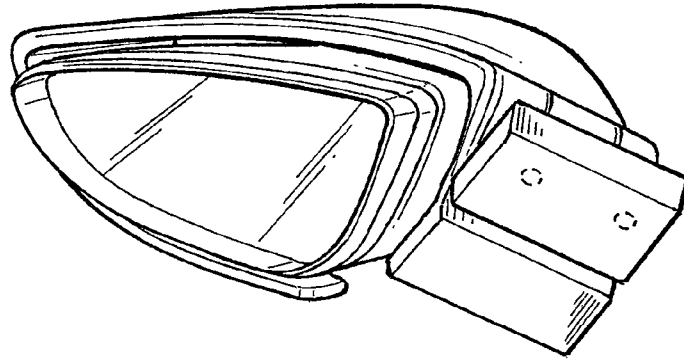

FIG. 1

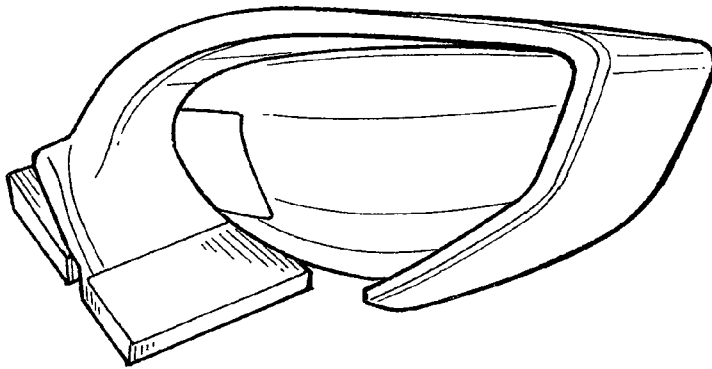

FIG. 2

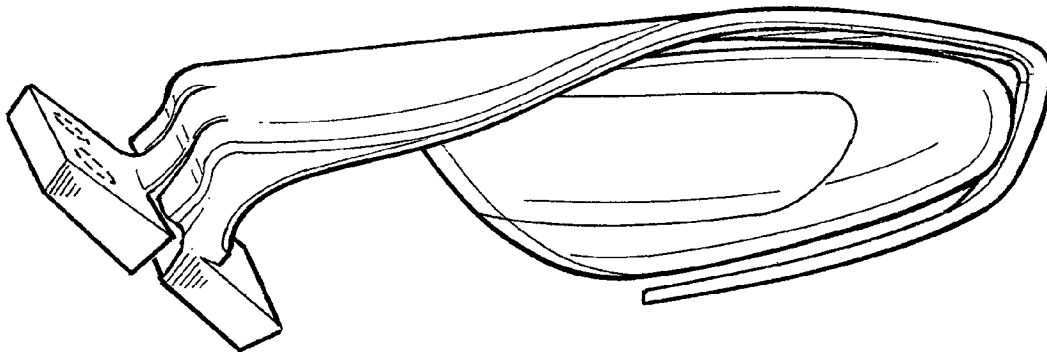

FIG. 3

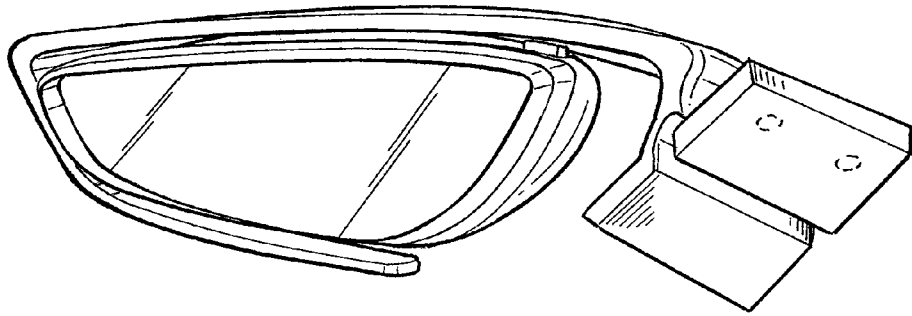

FIG. 4

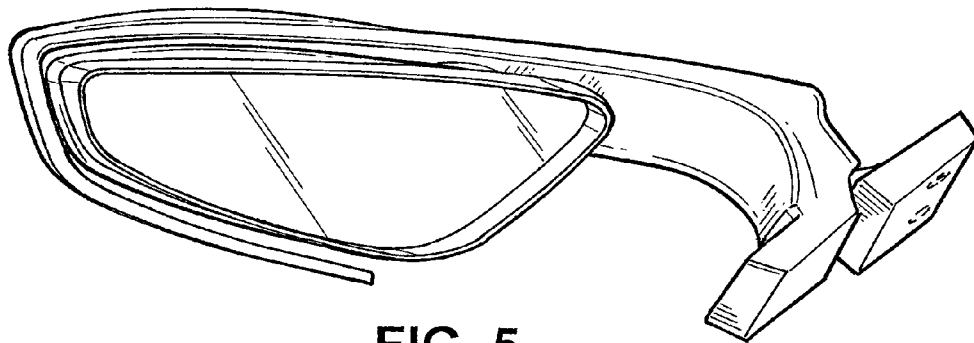

FIG. 5

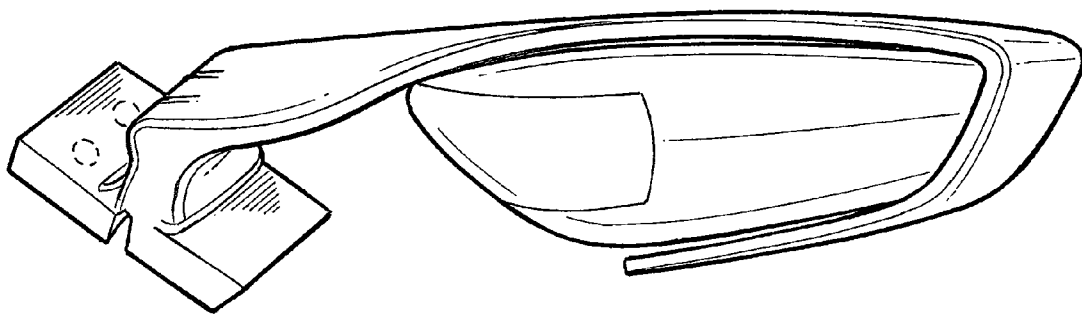

FIG. 6

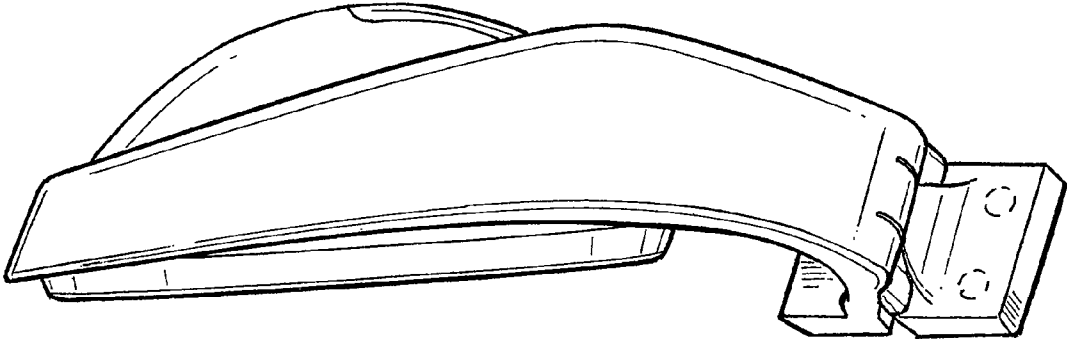

FIG. 7

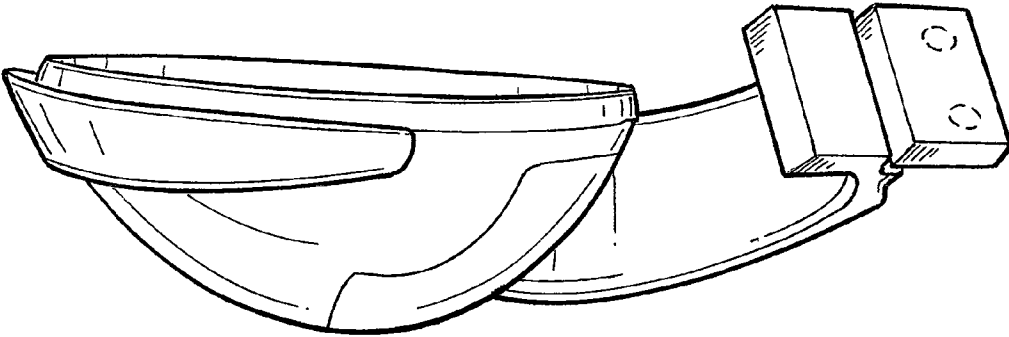

FIG. 8

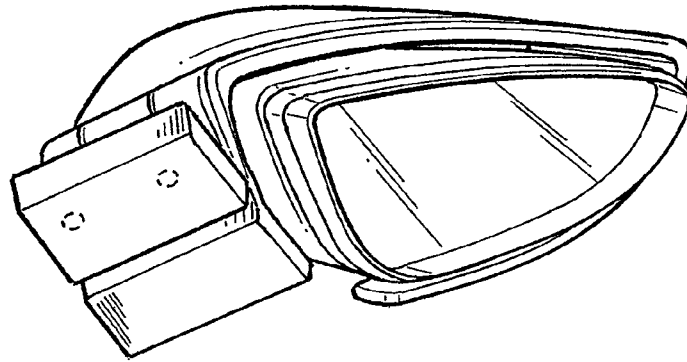

FIG. 9

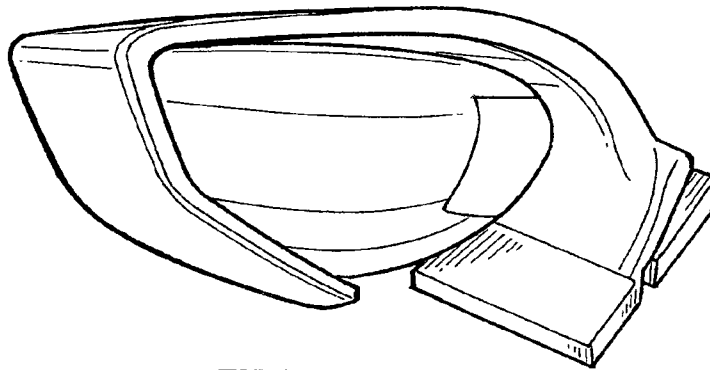

FIG. 10

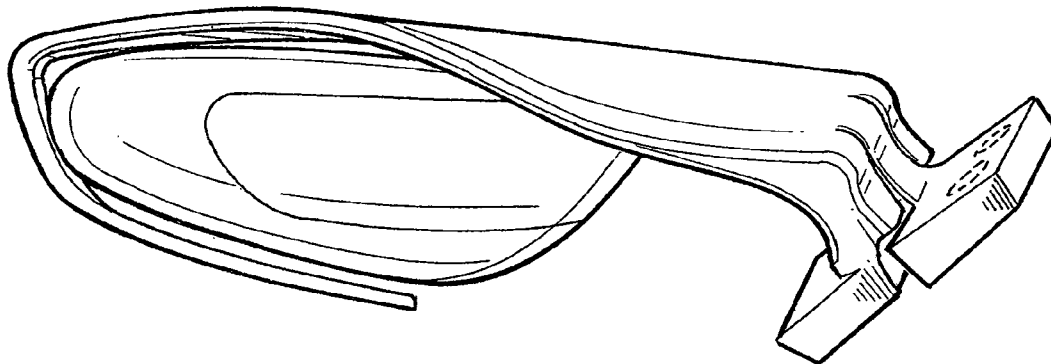

FIG. 11

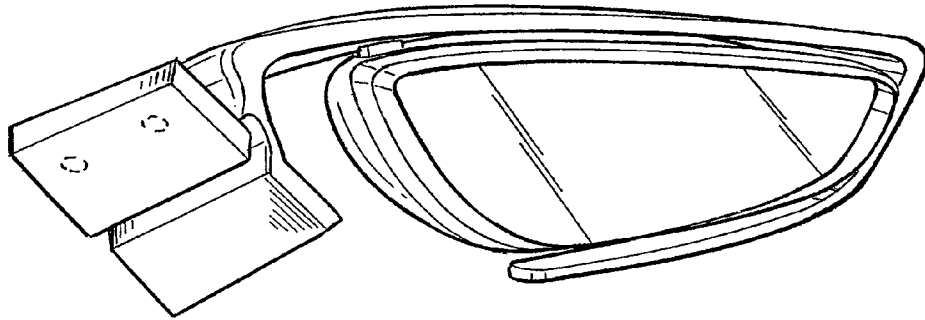

FIG. 12

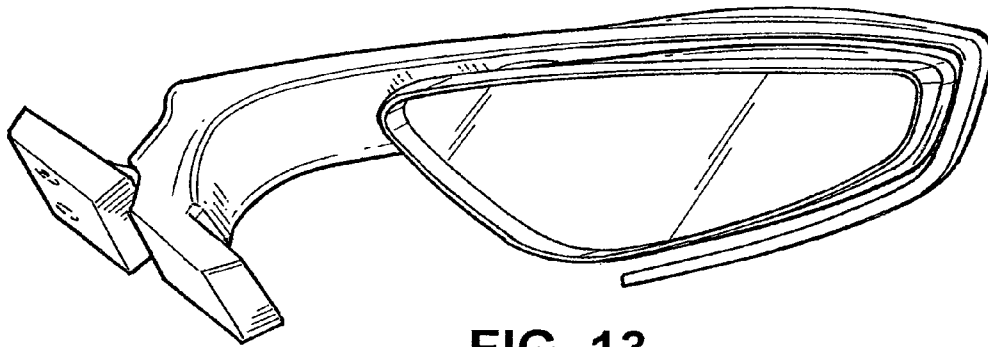

FIG. 13

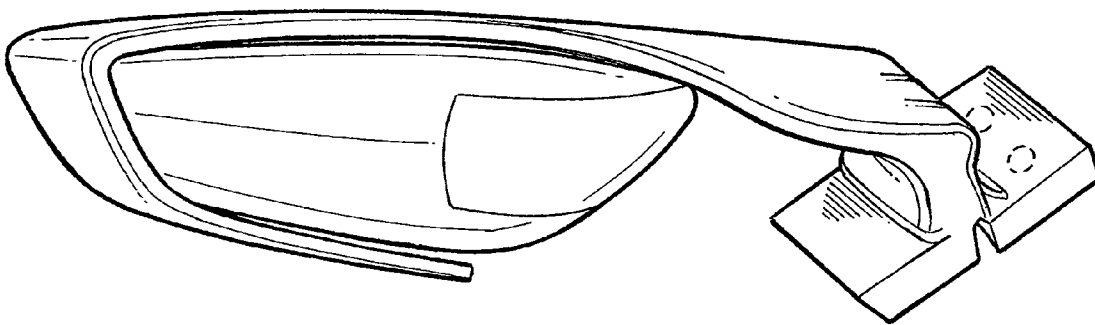

FIG. 14

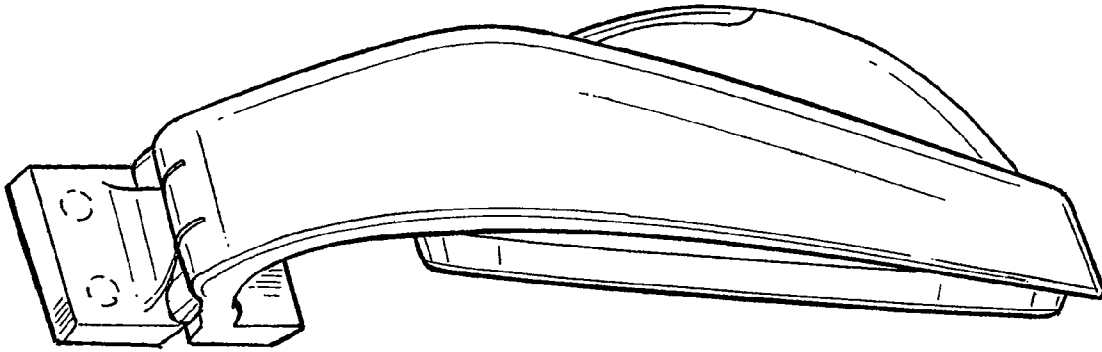

FIG. 15

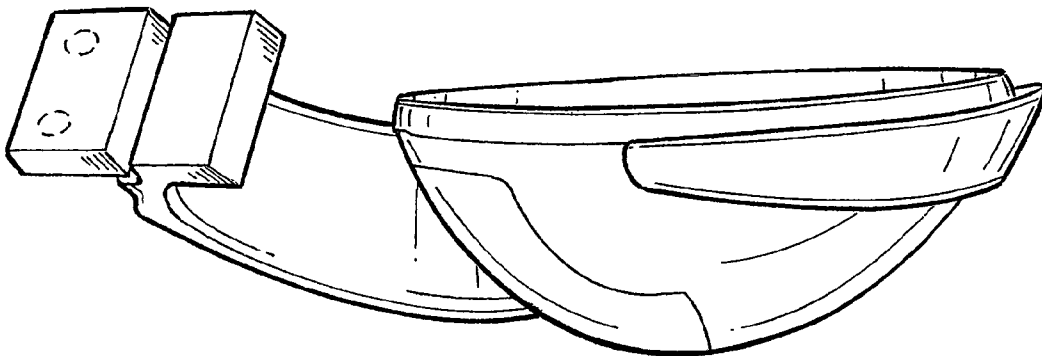

FIG. 16