

J. FELBEL.
TYPE WRITING MACHINE.
APPLICATION FILED JULY 15, 1903.

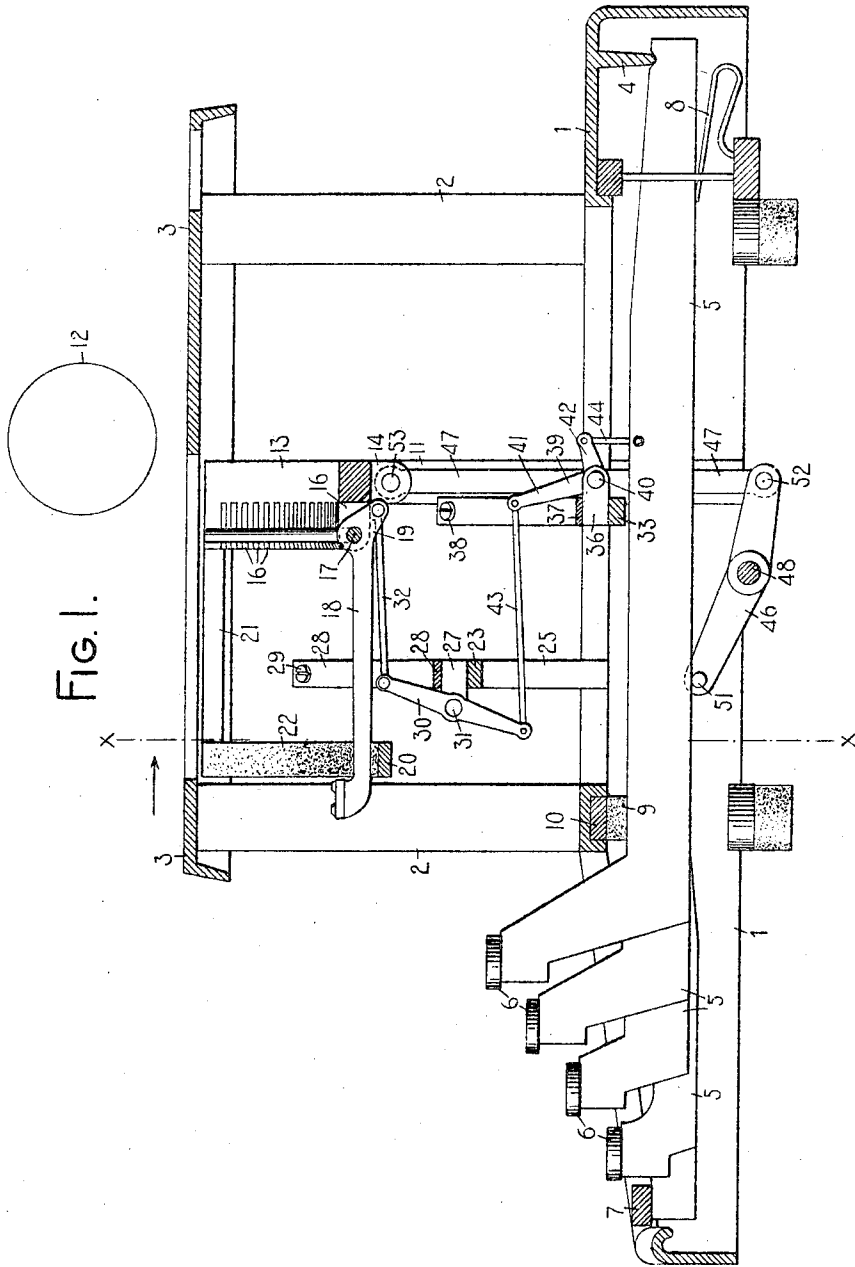

FIG. 1.

WITNESSES.

Daniel A. Carpenter.

R. V. Donovan.

INVENTOR.

Jacob Felbel

J. FELBEL.
TYPE WRITING MACHINE.
APPLICATION FILED JULY 16, 1903.

4 SHEETS—SHEET 2.

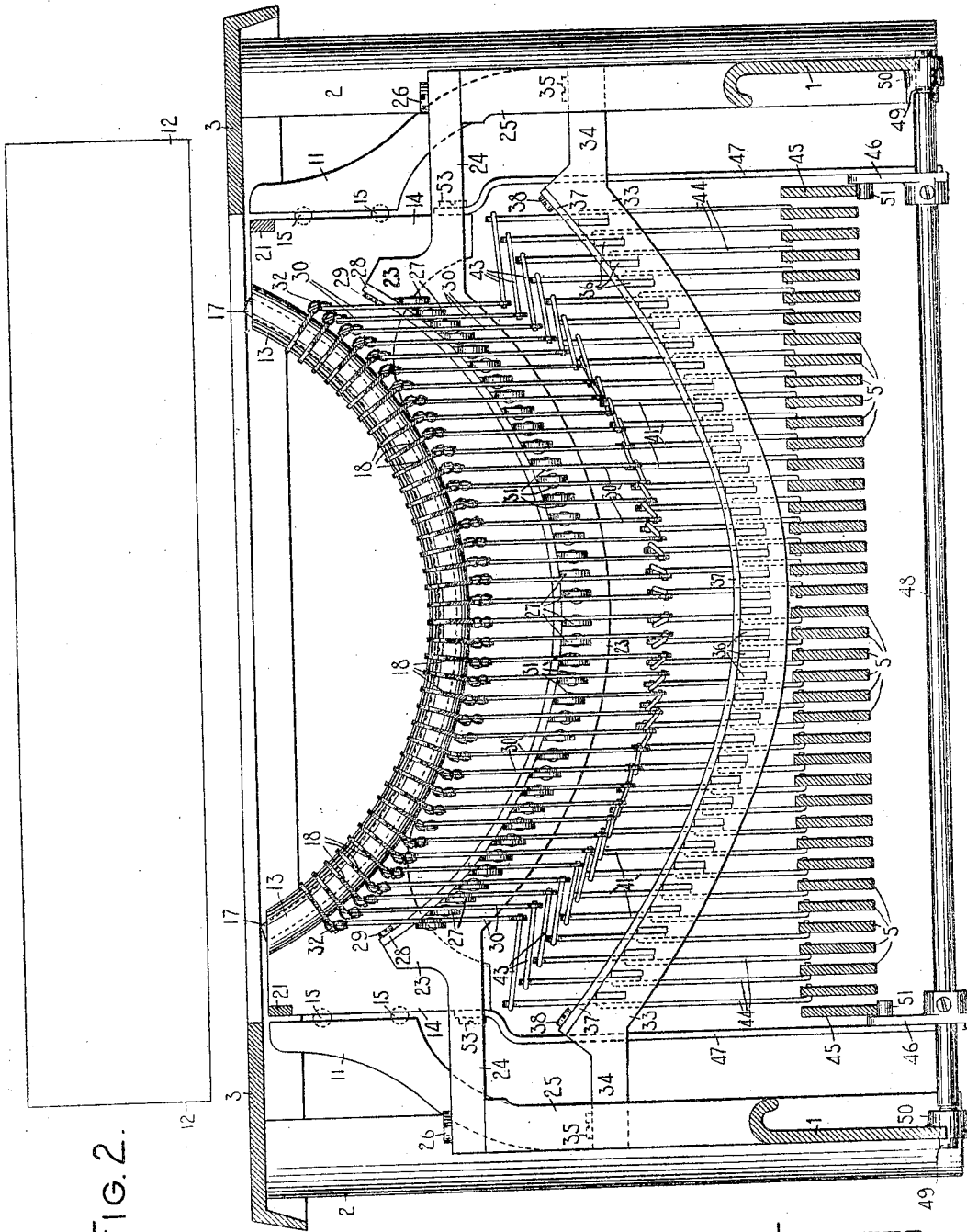
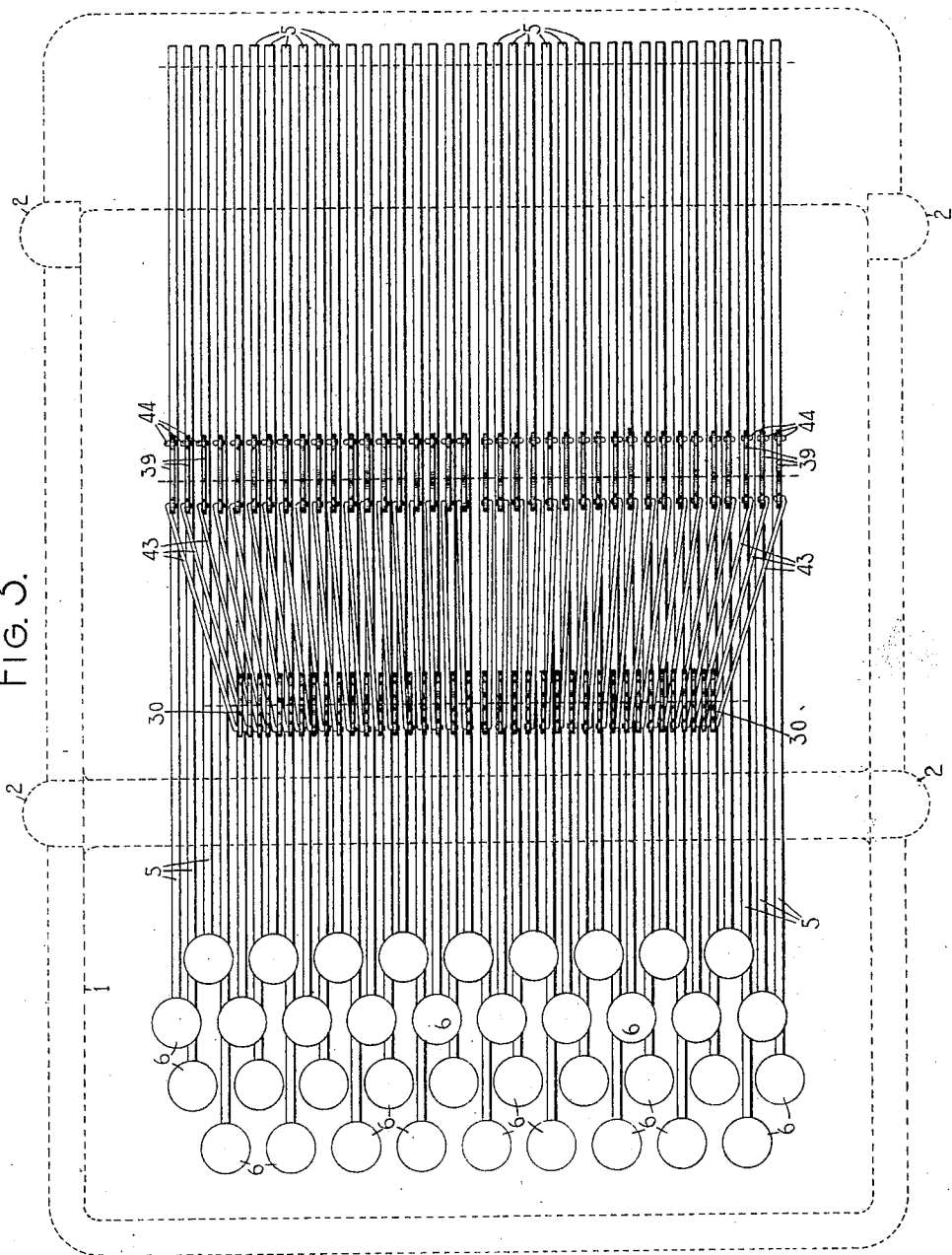

FIG. 2.
WITNESSES:
Daniel A. Carpenter.
H. V. Donovan.

INVENTOR:
Jacob Felbel

J. FELBEL.
TYPE WRITING MACHINE.
APPLICATION FILED JULY 15, 1903.

FIG. 3.



WITNESSES:
Daniel A. Carpenter.
H. V. Donovan.

INVENTOR:
Jacob Felbel

J. FELBEL.
TYPE WRITING MACHINE.
APPLICATION FILED JULY 15, 1903.

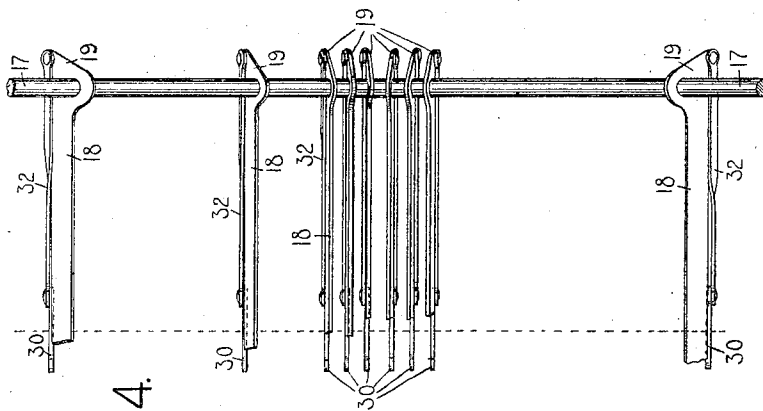

FIG. 4.

WITNESSES=

Daniel A. Carpenter.

K. V. Donovan.

INVENTOR=

Jacob Felbel

UNITED STATES PATENT OFFICE

JACOB FELBEL, OF NEW YORK, N. Y., ASSIGNOR TO UNION TYPEWRITER COMPANY, OF JERSEY CITY, NEW JERSEY, A CORPORATION OF NEW JERSEY.

TYPE-WRITING MACHINE.

No. 807,449.

Specification of Letters Patent.

Patented Dec. 19, 1905.

Application filed July 15, 1903. Serial No. 165,540.

To all whom it may concern:

Be it known that I, JACOB FELBEL, a citizen of the United States, and a resident of the borough of Manhattan, city of New York, in the county of New York and State of New York, have invented certain new and useful improvements in Type-Writing Machines, of which the following is a specification.

This invention relates to improvements in the type-actions of front-strike type-writing machines which comprise pivoted type-bars and mechanism to swing them on their pivots upward and backward to their printing positions, in which they act on the paper on the front of the platen and usually on or near the line on which the horizontal plane that contains the axis of the platen cuts the paper, the object of the invention being to provide such machines with highly-efficient type-actions composed of simple and easily-assembled parts and having various peculiar and desirable characteristics, which will be hereinafter explained.

The invention consists of the various features of construction and combinations and arrangements of parts, all as will be hereinafter more fully described, and particularly defined in the appended claims.

In the accompanying drawings, in which like reference-numerals designate like parts in the different views, Figure 1 is a central vertical section through the front and back of the frame of a front-strike type-writing machine with mechanism embodying certain parts of the invention applied thereto and an outline of the platen; Fig. 2, a front sectional elevation, on an enlarged scale, of the mechanism shown behind the plane *xx*, Fig. 1, with other type-actions added; Fig. 3, a plan of the finger-keys and key-levers and of sublevers and angular levers which are connected with the key-levers and type-bars and which are included in the type-actions, and Fig. 4 a plan of several type-bars and sublevers and links connecting the type-bars with the sublevers.

The frame of the machine is composed of the base 1, the posts 2, fast on the base, and the top plate 3, fast on the posts. In the rear part of the base 1 is a bar 4, which is the fulcrum of the key-levers 5, and on the key-levers at their front ends are keys 6, in front of which is a spacing-bar 7. Under each key-

lever near its rear end is a supporting and restoring spring 8, the key-lever being normally held by the spring in contact with a cushion 9 on the under side of a bar 10, which extends from side to side of the frame. Guides 11 are fixed in the frame a little in front of the vertical plane containing the axis of the platen 12, the guides being attached to the sides of the base 1. A type-bar segment 13 is mounted between these guides, there being brackets or guides 14 on the ends of the segment proper, and in grooves in these guides 11 and 14 are antifriction-balls 15. These parts are so adjusted that the segment is easily movable up and down, but cannot swerve laterally in the guides. The segment 13 contains a series of radial grooves or slots 16, cut in the front portion of the segment, the number of these slots being equal to the number of type-bars, and within a groove crossing the slots 16 at right angles and extending from end to end of the segment is a curved pivot-rod 17. Type-bars 18 are pivoted in the slots 16 on the rod 17, there being a type-bar in each of the slots 16. On the pivoted end of each type-bar is a short arm 19, in which is a hole forming a bearing for a pin affixed to an actuating-link. When the type-bars are in their normal positions, they extend forward from the segment 13 and rest near their front ends on the segment 20, which is secured to the segment 13 by bars 21 and provided with a pad 22, of soft material—such, for example, as felt.

At a suitable distance in front of a vertical plane containing the pivotal axes of the type-bars is fixed a support, to which are secured the sublevers, from which links extend to the type-bars. This support is composed of the curved central portion 23, whose upper face is concave and whose lower face is convex, and of the arms 24, formed on the curved portion 23. The arms rest on posts 25, to which they are fastened by screws 26 passing through the arms into the tops of the posts. These posts are affixed to the sides of the base 1 of the frame. In the concave face of the portion 23 of the support described are parallel slots, in which are fixed hangers 27, which project in front of the support and whose lateral faces are vertical. These hangers fit snugly in the slots in the support and are secured therein by a band 28, fastened to

the concave face of the portion 23 and held in contact with the upper edges of the hangers by screws 29. A system of sublevers 30 is supported by the hangers 27, there being
 5 a sublever pivoted to each hanger. The number of hangers is equal to the number of type-bars, so there are as many sublevers as there are type-bars.

The lateral faces of the sublevers are in vertical planes, and consequently the sublevers are parallel to one another, and they are so arranged that the upper end of each sublever is directly in front of a short arm 19 of one of the type-bars. The pivotal axes 31 of the
 10 sublevers are in a single vertical plane; but their elevations increase progressively from the middle to the sides of the system, and the arms of each sublever are equal to one another in length and symmetrical and equal in
 15 length to the arms of each other sublever of the system. The width of the system of sublevers or the distance across the system on a horizontal line is substantially equal to the width of the set of type-bars. Important advantages are derived from the peculiarities in the system of sublevers described, since all the sublevers of the system can be formed with a single set of dies, and they are interchangeable and each is reversible, so in assembling the levers it is not necessary to exercise care in securing any lever to a particular hanger or in making either end of the lever its upper or lower end. These sublevers extend above and below their pivotal axes 31, and their upper ends are connected with the arms 19 of the type-bars by links 32, these links, with the exception of those at the middle of the series, being twisted between their ends, as shown in Fig. 4, to facilitate their connection with the type-bars and sublevers. Each sublever is movable at its ends on arcs whose chords are substantially horizontal. When the sublevers are in their normal positions, their upper ends are behind and their lower ends in front of the vertical plane which contains their pivotal axes, the sublevers being preferably so arranged that when they are operated to actuate the type-bars the ends of each lever move from side to side of this vertical plane and through equal distances on each side of the plane. The arms of each sublever preferably extend from its pivotal axis in diametrically opposite directions; but obviously sublevers differing to a considerable extent in form, as well as in arrangement, from the sublevers 30 might be substituted for these levers without avoiding the spirit of the invention.

Behind and below the support on which the sublevers 30 are mounted is another similar support composed of a concavo-convex portion 33 and laterally-extending arms 34. The arms of this support rest on posts attached to the base 1 of the frame behind the posts 25
 60 and are secured on the posts by screws pass-

ing through the arms into the posts, the screws 35 being shown in dotted lines in Fig. 2. In the concavo-convex portion 33 of this support are fixed hangers 36, similar to the hangers 27, above described. The hangers 36 are held in vertical slots cut in the support and are secured therein by a band 37, attached by screws 38 to the support and bearing on the upper edges of the hangers. To these hangers, which extend behind the support, are pivoted angular levers 39, the hangers being so arranged that there is an angular lever directly over each key-lever. The hangers 27 and 36 are both adjustable fore and aft of the machine in order that the parts may be assembled with precision. The width of the set of angular levers is consequently equal to that of the set of key-levers, which is greater than the width of the system of sublevers and of the set of type-bars. The axes of the pivots 40, by which the angular levers are secured to the hangers 36, are all in a single vertical plane; but their elevations increase progressively from the middle to the sides of the set of angular levers. All the angular levers of the set are alike and they are arranged parallel to one another, the end of the longer arm 41 of each angular lever being at the same or about the same level as is the lower end of the corresponding sublever. The longer arm 41 and shorter arm 42 of each of the angular levers are inclined forward and upward, respectively, from the vertical and horizontal planes that contain the pivotal axis of the lever when the lever is in its normal position. The longer arms 41 are connected with the lower arms of the sublevers 30 by links 43, and the shorter arms 42 are connected with the key-levers by links 44. The links 43, which are nearly horizontal, diverge from one another, as shown in Fig. 3, from their front to their rear ends, or from the system of sublevers 30 to the wider set of angular levers 39. The links 44 are substantially vertical and increase progressively in length from the middle to the sides of the series, as appears in Fig. 2.

The segment 13, on which are mounted the type-bars, is movable vertically to enable upper-case as well as lower-case printing to be done. The upward movement of the segment is produced by means of shift-levers 45, similar to the key-levers, lifting-levers 46, and links 47. The shift-levers bear at their rear ends against the fulcrum 4 and are normally held against the cushion 9 by springs like the springs 8. At their front ends, which are at the sides of the keyboard of the machine, they are provided with keys or finger-pieces similar to those of the key-levers 5. The lifting-levers 46 are fast on a shaft 48, which is mounted on screw-pivots 49, secured in bosses 50, formed on the base 1 of the frame, and on the front arms of the levers 46 are studs 51, with which the shift-levers 45 make

contact. The links 47 are pivoted at their lower ends to the rear arms of the levers 46 and at their upper ends to the brackets 14 of the segment 13 by pivots 52 and 53, respectively. When the finger-key of a shift-lever is depressed to the full extent of its movement, the shaft 48 is rocked by the action of the shift-lever on the front arm of one of the levers 46, and the rear arms of the levers 46, acting through the links 47 on the segment 13, raise the segment and type-bars to the elevated position required for upper-case printing, the links 32 vibrating on their pivotal connections with the sublevers 30. The segment and type-bars descend by gravity to the lower-case position and by their action on the links 47, levers 46, and shaft 48 restore these parts to their normal positions.

In the operation of the type-actions above described only slight lateral or twisting strains are developed, even in the type-actions which are next to or near the sides of the system, while elsewhere in the system either no such strains are developed or any that are developed are too light to even noticeably affect the operation of the mechanism. A type-bar is actuated with the depression of its finger-key by the downward action of the key-lever on the link 44 and of this link on the angular lever 39, the backward pull of the angular lever on the link 43 and of this link on the lower arm of the sublever 30, and the forward pull of the upper arm of the sublever on the link 32 and of this link on the arm 19 of the type-bar. The type-bar and other parts of the type-action are restored to their normal positions by the action of gravity on the type-bar and of the restoring-spring 8, exerting an upward pressure on the key-lever.

For the angular levers 39 it would be practicable to substitute other levers or devices properly formed and arranged and connected with the key-levers and sublevers to render them operative in imparting the required movements to the sublevers. In view of this the invention is not restricted to mechanism embodying the particular angular levers which are shown herein. It is to be observed, further, that the mechanism claimed might be applied to a machine comprising means for shifting the platen to provide for upper-case printing instead of the above-described segment-shifting mechanism or a machine having only one type on a bar and no shift at all. Also various other changes besides those indicated may be made in the mechanism above described without avoiding the spirit of the invention. For example, the key-levers may be of some other type, and the type-bars may have individual pivots and hangers instead of being mounted on the fulcrum-wire 17 common to all of the type-bars.

What I claim as new, and desire to secure by Letters Patent, is—

65 1. In a type-writing machine, the combina-

tion of a set of front-strike pivoted type-bars, a set of key-actuated devices, a system of levers each having arms of equal length and movable at its ends on arcs whose chords are substantially horizontal, means connecting the ends of said levers on one side of their pivotal axes with the type-bars, and means connecting the other ends of said levers with the key-actuated devices. 70

2. In a type-writing machine, the combination of a set of front-strike pivoted type-bars, a set of key-actuated devices, a system of levers each having arms of equal length and movable at its ends on arcs whose chords are substantially horizontal, links pivoted to the ends of said levers on one side of their pivotal axes and to the type-bars, and means connecting the other ends of said levers with the key-actuated devices. 75

3. In a type-writing machine, the combination of a set of front-strike pivoted type-bars, a set of key-actuated devices, a system of levers each having arms of equal length and movable at its ends on arcs whose chords are substantially horizontal, means connecting the ends of said levers on one side of their pivotal axes with the type-bars, and links pivoted to the other ends of said levers and to the key-actuated devices. 80

4. In a type-writing machine, the combination of a set of front-strike pivoted type-bars, a set of key-actuated devices, a system of levers each having arms of equal length and movable at its ends on arcs whose chords are substantially horizontal, links pivoted to the ends of said levers on one side of their pivotal axes and to the type-bars, and links pivoted to the other ends of said levers and to the key-actuated devices. 85

5. In a type-writing machine, the combination of a set of front-strike pivoted type-bars, a set of key-levers, a system of sublevers each having arms of equal length and movable at its ends on arcs whose chords are substantially horizontal, means connecting the ends of said sublevers on one side of their pivotal axes with the type-bars, and means connecting the other ends of said sublevers with the key-levers. 90

6. In a type-writing machine, the combination of a set of front-strike pivoted type-bars, a set of key-levers, a system of sublevers each having arms of equal length and movable at its ends on arcs whose chords are substantially horizontal, links pivoted to the ends of said sublevers on one side of their pivotal axes and to the type-bars, and means connecting the other ends of said sublevers with the key-levers. 95

7. In a type-writing machine, the combination of a set of front-strike pivoted type-bars, a set of key-levers, a system of sublevers each having arms of equal length and movable at its ends on arcs whose chords are substantially horizontal, means connecting the ends 100

105

110

115

120

125

130

of said sublevers on one side of their pivotal axes with the type-bars, and links pivoted to the other ends of said sublevers and operatively connected with the key-levers.

5 8. In a type-writing machine, the combination of a set of front-strike pivoted type-bars, a set of key-actuated devices, a system of levers each having arms equal to one another and to those of each other lever of the system
10 in length, and movable at its ends on arcs whose chords are substantially horizontal, means connecting the ends of said levers on one side of their pivotal axes with the type-bars, and means connecting the other ends of
15 said levers with the key-actuated devices.

9. In a type-writing machine, the combination of a set of front-strike pivoted type-bars, a set of key-actuated devices, a system of levers each having arms equal to one another
20 and to those of each other lever of the system in length, and movable at its ends on arcs whose chords are substantially horizontal, links pivoted to the ends of said levers on one side of their pivotal axes and to the type-bars,
25 and means connecting the other ends of said levers with the key-actuated devices.

10. In a type-writing machine, the combination of a set of front-strike pivoted type-bars, a set of key-actuated devices, a system
30 of levers each having arms equal to one another and to those of each other lever of the system in length, and movable at its ends on arcs whose chords are substantially horizontal, means connecting the ends of said levers
35 on one side of their pivotal axes with the type-bars, and links pivoted to the other ends of said levers and to the key-actuated devices.

11. In a type-writing machine, the combination of a set of front-strike pivoted type-bars,
40 a set of key-levers, a system of sublevers each having arms equal to one another and to those of each other sublever of the system in length, and movable at its ends on arcs whose chords are substantially horizontal, means connecting
45 the ends of said sublevers on one side of their pivotal axes with the type-bars, and means connecting the other ends of said sublevers with the key-levers.

12. In a type-writing machine, the combination of a set of front-strike pivoted type-bars,
50 a set of key-levers, a system of sublevers each having arms equal to one another and to those of each other sublever of the system in length, and movable at its ends on arcs whose chords
55 are substantially horizontal, means connecting the ends of said sublevers on one side of their pivotal axis with the type-bars, and links pivoted to the other ends of said sublevers and operatively connected with the key-levers.

60 13. In a type-writing machine, the combination of a set of front-strike pivoted type-bars, a set of key-actuated devices, a system of levers supported in front of a vertical plane
cutting the set of type-bars near their pivotal
65 axes, each of said levers being movable at its

ends on arcs whose chords are substantially horizontal, means connecting the upper arms of said levers with the type-bars, and means connecting their lower arms with the key-actuated devices.

14. In a type-writing machine, the combination of a set of front-strike pivoted type-bars, a set of key-levers, a system of sublevers supported in front of a vertical plane cutting the set of type-bars near their pivotal axes, each
70 of the sublevers being movable at its ends on arcs whose chords are substantially horizontal, means connecting the upper arms of the sublevers with the type-bars, and means connecting their lower arms with the key-levers. 75

15. In a type-writing machine, the combination of a set of front-strike pivoted type-bars, a set of key-levers, a system of sublevers supported in front of a vertical plane cutting the set of type-bars near their pivotal axes, each
80 of the sublevers being movable at its ends on arcs whose chords are substantially horizontal, links pivoted to the upper arms of the sublevers and to the type-bars, and links pivoted to the lower arms of the sublevers and
85 operatively connected with the key-levers. 90

16. In a type-writing machine, the combination of a set of front-strike pivoted type-bars, a set of key-actuated devices, a system of levers supported in front of a vertical plane
95 cutting the set of type-bars near their pivotal axes, each of said levers having upper and lower arms and being movable at its ends from side to side of a vertical plane containing its pivotal axis, means connecting the upper arms
100 of said levers with the type-bars, and means connecting their lower arms with the key-actuated devices. 100

17. In a type-writing machine, the combination of a set of front-strike pivoted type-bars,
105 a set of key-levers, a system of sublevers supported in front of a vertical plane cutting the set of type-bars near their pivotal axes, each of said sublevers having upper and lower arms and being movable at its ends from side to
110 side of a vertical plane containing its pivotal axis, means connecting the upper arms of the sublevers with the type-bars, and means connecting their lower arms with the key-levers. 110

18. In a type-writing machine, the combination of a set of front-strike pivoted type-bars,
115 a set of key-actuated devices, a system of levers at its ends on arcs whose chords are substantially horizontal and said pivots being at elevations progressively increasing from the
120 middle to the sides of the system, means connecting the upper arms of said levers with the type-bars, and means connecting the lower arms of said levers with the key-actuated devices. 125

19. In a type-writing machine, the combination of a set of front-strike pivoted type-bars, a set of key-levers, a system of sublevers at
its ends on arcs whose chords are substantially
130 horizontal and said pivots being at elevations 130

progressively increasing from the middle to the sides of the system, means connecting the upper arms of said sublevers with the type-bars, and means connecting the lower arms of said sublevers with the key-levers.

20. In a type-writing machine, the combination of a set of front-strike pivoted type-bars, a set of key-levers, a system of sublevers having their pivotal axes at elevations progressively increasing from the middle to the sides of the system, each of said sublevers being movable at its ends on arcs whose chords are substantially horizontal, links pivoted to the upper arms of said sublevers and to the type-bars, and means connecting the lower arms of said sublevers with the key-levers.

21. In a type-writing machine, the combination of a set of front-strike pivoted type-bars, a set of key-levers, a system of sublevers having their pivotal axes at elevations progressively increasing from the middle to the sides of the system, each sublever of the system being movable at its ends on arcs whose chords are substantially horizontal and having its arms equal to one another and to those of each other sublever of the system in length, means connecting the upper arms of said sublever with the type-bars, and means connecting the lower arms of said sublevers with the key-levers.

22. In a type-writing machine, the combination of a set of front-strike pivoted type-bars, a set of key-actuated devices, a system of levers supported in front of a vertical plane cutting the set of type-bars near their pivotal axes, said levers having their pivotal axes at elevations progressively increasing from the middle to the sides of the system and each of said levers being movable at its ends on arcs whose chords are substantially horizontal, means connecting the upper arms of said levers with the type-bars, and means connecting the lower arms of said levers with the key-actuated devices.

23. In a type-writing machine, the combination of a set of front-strike pivoted type-bars, a set of key-levers, a system of sublevers supported in front of a vertical plane cutting the set of type-bars near their pivotal axes, said sublevers having their pivotal axes at elevations progressively increasing from the middle to the sides of the system and each of said sublevers being movable at its ends on arcs whose chords are substantially horizontal, means connecting the upper arms of the sublevers with the type-bars, and means connecting the lower arms of the sublevers with the key-levers.

24. In a type-writing machine, the combination of a set of front-strike pivoted type-bars, a set of key-levers, a system of sublevers supported in front of a vertical plane cutting the set of type-bars near their pivotal axes, said sublevers having their pivotal axes at elevations progressively increasing from the middle

to the sides of the system, and each of said sublevers being movable at its ends on arcs whose chords are substantially horizontal, links pivoted to the upper arms of the sublevers and to the type-bars, and links pivoted to the lower arms of the sublevers and operatively connected with the key-levers.

25. In a type-writing machine, the combination of a set of front-strike pivoted type-bars, a set of key-actuated devices, a system of levers, each movable at its ends on arcs whose chords are substantially horizontal, means connecting said levers with the type-bars, and means connecting said levers with the key-actuated devices, all the levers of said system being interchangeable with one another.

26. In a type-writing machine, the combination of a set of front-strike pivoted type-bars, a set of key-levers, a system of sublevers, each movable at its ends on arcs whose chords are substantially horizontal, means connecting the sublevers with the type-bars, and means connecting the sublevers with the key-levers, all the sublevers of said system being interchangeable with one another.

27. In a type-writing machine, the combination of a set of front-strike pivoted type-bars, a set of key-actuated devices, a system of levers, each movable at its ends on arcs whose chords are substantially horizontal, means connecting said levers with the type-bars, and means connecting said levers with the key-actuated devices, each lever of said system being normally operative in a reversed position.

28. In a type-writing machine, the combination of a set of front-strike pivoted type-bars, a set of key-actuated devices, a system of levers, each movable at its ends on arcs whose chords are substantially horizontal, means connecting said levers with the type-bars, and means connecting said levers with the key-actuated devices, all the levers of said system being interchangeable with one another and each lever thereof being normally operative in a reversed position.

29. In a type-writing machine, the combination of a set of front-strike pivoted type-bars, a set of key-actuated devices, a system of straight levers each having symmetrical arms and being movable at its ends on arcs whose chords are substantially horizontal, means connecting the ends of said levers on one side of their axes with the type-bars, and means connecting the other ends of said levers with the key-actuated devices.

30. In a type-writing machine, the combination of a set of front-strike pivoted type-bars, a set of key-levers, a system of sublevers each having symmetrical arms and being movable at its ends on arcs whose chords are substantially horizontal, links pivoted to the ends of the sublevers on one side of their axes and to the type-bars, and links pivoted to the other ends of the sublevers and operatively connected with the key-levers.

31. In a type-writing machine, the combination of a front-strike pivoted type-bar, a lever supported in front of a vertical plane cutting the type-bar near its pivotal axis, said lever having upper and lower arms, a key-actuated device behind the vertical plane containing the axis of said lever, means connecting the upper arm of said lever with the type-bar, and means extending backward from the lower arm of said lever and connecting it with the key-actuated device.

32. In a type-writing machine, the combination of a front-strike pivoted type-bar, a sublever supported in front of a vertical plane cutting the type-bar near its pivotal axis, said sublever having upper and lower arms, a key-lever, means connecting the upper arm of said sublever with the type-bar, and means attached to and extending backward from the lower arm of said sublever and operatively connected with the key-lever.

33. In a type-writing machine, the combination of a front-strike pivoted type-bar, a sublever supported in front of a vertical plane cutting the type-bar near its pivotal axis, said sublever having upper and lower arms, a key-lever, a link extending backward from the upper arm of said sublever and connecting it with the type-bar, and another link attached to and extending backward from the lower arm of said sublever and operatively connected with the key-lever.

34. In a type-writing machine, the combination of a front-strike pivoted type-bar, a sublever supported in front of a vertical plane cutting the type-bar near its pivotal axis, said sublever having upper and lower arms, a key-actuated angular lever supported behind the vertical plane containing the axis of said sublever, means connecting the upper arm of said sublever with the type-bar, and means extending backward from the lower arm of said sublever and connecting it with the angular lever.

35. In a type-writing machine, the combination of a front-strike pivoted type-bar, a sublever supported in front of a vertical plane cutting the type-bar near its pivotal axis, said sublever having upper and lower arms, a key-actuated angular lever supported behind the vertical plane containing the axis of said sublever, a link extending backward from the upper arm of said sublever and connecting it with the type-bar, and another link extending backward from the lower arm of said sublever and connecting it with the angular lever.

36. In a type-writing machine, the combination of a front-strike pivoted type-bar, a sublever supported in front of a vertical plane cutting the type-bar near its pivotal axis, said sublever having upper and lower arms, an angular lever supported behind a vertical plane containing the axis of said sublever, a key-lever, and devices forming with said sublever and angular lever operative connections between the key-lever and type-bar.

37. In a type-writing machine, the combination of a front-strike pivoted type-bar, a sublever supported in front of a vertical plane cutting the type-bar near its pivotal axis, said sublever having upper and lower arms, an angular lever supported behind a vertical plane containing the axis of said sublever, a key-lever, and links connecting said levers with one another and with the type-bar.

38. In a type-writing machine, the combination of a set of front-strike pivoted type-bars, a system of parallel levers, equal in width to the set of type-bars, a set of parallel key-actuated devices, wider than said system of levers, means connecting said levers with the type-bars, and means connecting said levers with the key-actuated devices.

39. In a type-writing machine, the combination of a set of front-strike pivoted type-bars, a system of parallel sublevers, equal in width to the set of type-bars, a set of parallel key-levers, wider than the system of sublevers, means connecting the sublevers with the type-bars, and means connecting the sublevers with the key-levers.

40. In a type-writing machine, the combination of a set of front-strike pivoted type-bars, a system of parallel sublevers, equal in width to the set of type-bars, a set of parallel key-levers, wider than the system of sublevers, links pivoted to the sublevers and to the type-bars, and other links pivoted to the sublevers and operatively connected with the key-levers.

41. In a type-writing machine, the combination of a set of front-strike pivoted type-bars, a system of parallel sublevers, equal in width to the set of type-bars, a set of parallel key-actuated angular levers, wider than the system of sublevers, means connecting said sublevers with the type-bars, and means connecting said sublevers with the angular levers.

42. In a type-writing machine, the combination of a set of front-strike pivoted type-bars, a system of parallel sublevers, equal in width to the set of type-bars, a set of parallel key-actuated angular levers, wider than the system of sublevers, links pivoted to said sublevers and to the type-bars, and links pivoted to said sublevers and to said angular levers.

43. In a type-writing machine, the combination of a set of front-strike pivoted type-bars, a system of parallel sublevers in front of a vertical plane cutting the set of type-bars near their pivotal axes, said system being equal in width to the set of type-bars, a set of parallel key-actuated angular levers behind the sublevers, said set of angular levers being wider than said system of sublevers, means connecting said sublevers with the type-bars, and means connecting said sublevers with said angular levers.

44. In a type-writing machine, the combination of a set of front-strike pivoted type-bars, a system of parallel sublevers in front of a vertical plane cutting the set of type-bars near

their pivotal axes, said system being equal in width to the set of type-bars, a set of parallel key-actuated angular levers behind the sub-levers, said set of angular levers being wider than said system of sublevers, links pivoted to said sublevers and to the type-bars, and other links pivoted to said sublevers and to said angular levers.

45. In a type-writing machine, the combination of a set of front-strike pivoted type-bars, a system of levers having their pivotal axes at elevations progressively increasing from the middle to the sides of the system, said levers extending above their pivotal axes, connections extending from said levers above their pivotal axes to the type-bars, and key-actuated means operative to move the upper ends of said levers in substantially horizontal directions from their normal positions and away from a vertical plane cutting the type-bars near their pivotal axes, said means including a set of pivoted devices having their pivotal axes at elevations progressively increasing from the middle to the sides of said set of devices, and connections extending from said devices to said levers.

46. In a type-writing machine, the combination of a set of front-strike pivoted type-bars, a system of levers having their pivotal axes at elevations progressively increasing from the middle to the sides of the system, each of said levers being movable at its ends on arcs whose chords are more nearly horizontal than vertical, a set of pivoted key-actuated devices having their pivotal axes at elevations progressively increasing from the middle to the sides of said set of devices, means connecting said levers with the type-bars, and means connecting said levers with said key-actuated devices.

47. In a type-writing machine, the combination of a set of front-strike pivoted type-bars, a system of sublevers having their pivotal axes at elevations progressively increasing from the middle to the sides of the system, a set of key-actuated angular levers having their pivotal axes at elevations progressively increasing from the middle to the sides of said set of angular levers, means connecting said sublevers with the type-bars, and means connecting said sublevers with said angular levers.

48. In a type-writing machine, the combination of a set of front-strike pivoted type-bars, a system of sublevers having their pivotal axes at elevations progressively increasing from the middle to the sides of the system, a system of key-actuated angular levers having their pivotal axes at elevations progressively increasing from the middle to the sides of said system, links pivoted to said sublevers and to the type-bars, and links pivoted to said sublevers and to said angular levers.

49. In a type-writing machine, the combination of a set of front-strike pivoted type-bars, a system of parallel levers, equal in width to the

set of type-bars, said levers having their pivotal axes at elevations progressively increasing from the middle to the sides of the system, a set of pivoted and parallel key-actuated devices, wider than said system of levers, said devices having their pivotal axes at elevations progressively increasing from the middle to the sides of said set of devices, means connecting said levers with the type-bars, and means connecting said levers with said key-actuated devices.

50. In a type-writing machine, the combination of a set of front-strike pivoted type-bars, a system of parallel sublevers, equal in width to the set of type-bars, said sublevers having their pivotal axes at elevations progressively increasing from the middle to the sides of the system, a set of parallel key-actuated angular levers, wider than said system of sublevers, said angular levers having their pivotal axes at elevations progressively increasing from the middle to the sides of said set of angular levers, means connecting said sublevers with the type-bars, and means connecting said sublevers with said angular levers.

51. In a type-writing machine, the combination of a set of front-strike pivoted type-bars, a system of parallel sublevers, equal in width to the set of type-bars, said sublevers having their pivotal axes at elevations progressively increasing from the middle to the sides of the system, a system of parallel key-actuated angular levers, wider than said system of sublevers, said angular levers having their pivotal axes at elevations progressively increasing from the middle to the sides of said system, links pivoted to said sublevers and to the type-bars, and other links pivoted to said sublevers and to said angular levers.

52. In a type-writing machine, the combination of a set of front-strike pivoted type-bars, a system of parallel sublevers, equal in width to the set of type-bars, a set of parallel key-levers, wider than the system of sublevers, a third set of parallel levers, equal in width to the set of key-levers, connections between the type-bars and sublevers, connections between the key-levers and the levers of said third set, and connections between the last-mentioned levers and the sublevers.

53. In a type-writing machine, the combination of a set of front-strike pivoted type-bars, a system of parallel sublevers, equal in width to the set of type-bars, a set of parallel key-levers, wider than the system of sublevers, a set of parallel angular levers, equal in width to the set of key-levers, connections between the type-bars and sublevers, connections between the key-levers and angular levers, and connections between the angular levers and sublevers.

54. In a type-writing machine, the combination of a set of front-strike pivoted type-bars, a system of parallel sublevers in front of a vertical plane cutting the set of type-bars near

their pivotal axes, said system being equal in width to the set of type-bars, a set of parallel key-levers, wider than the system of sublevers, a third set of parallel levers above the key-levers and behind the sublevers, said third set of levers being equal in width to the set of key-levers, connections between the type-bars and sublevers, connections between the key-levers and the levers of said third set, and connections between the last-mentioned levers and the sublevers.

55. In a type-writing machine, the combination of a set of front-strike pivoted type-bars, a system of parallel sublevers in front of a vertical plane cutting the set of type-bars near their pivotal axes, said system being equal in width to the set of type-bars, a set of parallel key-levers, wider than the system of sublevers, a set of parallel angular levers above the key-levers and behind the sublevers, said set of angular levers being equal in width to the set of key-levers, connections between the type-bars and sublevers, connections between the key-levers and angular levers, and connections between the angular levers and sublevers.

56. In a type-writing machine, the combination of a set of front-strike pivoted type-bars, a system of parallel sublevers, equal in width to the set of type-bars, the sublevers of said system having their pivotal axes at elevations progressively increasing from the middle to the sides of the system, a set of parallel key-levers, wider than the system of sublevers, a third set of parallel levers, equal in width to the set of key-levers, the levers of said third set having their pivotal axes at elevations progressively increasing from the middle to the sides of the set, connections between the type-bars and sublevers, connections between the key-levers and the levers of said third set, and connections between the last-mentioned levers and the sublevers.

57. In a type-writing machine, the combination of a set of front-strike pivoted type-bars, a system of parallel sublevers in front of a vertical plane cutting the set of type-bars near their pivotal axes, said system being equal in width to the set of type-bars, and the sublevers of said system having their pivotal axes at elevations progressively increasing from the middle to the sides of the system, a set of parallel key-levers, wider than the system of sublevers, a third set of parallel levers above the key-levers and behind the sublevers, said third set of levers being equal in width to the set of key-levers, and the levers of said third set having their pivotal axes at elevations progressively increasing from the middle to the sides of the set, connections between the type-bars and sublevers, connections between the key-levers and the levers of said third set, and connections between the last-mentioned levers and the sublevers.

58. In a type-writing machine, the combina-

tion of a set of front-strike pivoted type-bars, a system of parallel sublevers in front of a vertical plane cutting the set of type-bars near their pivotal axes, said system being equal in width to the set of type-bars, and the sublevers of said system having their pivotal axes at elevations progressively increasing from the middle to the sides of the system, a set of parallel key-levers, wider than the system of sublevers, a set of parallel angular levers above the key-levers and behind the sublevers, said set of angular levers being equal in width to the set of key-levers, and said angular levers having their pivotal axes at elevations progressively increasing from the middle to the sides of the set, connections between the type-bars and sublevers, connections between the key-levers and angular levers, and connections between the angular levers and sublevers.

59. In a type-writing machine, the combination of a set of front-strike pivoted type-bars, a system of parallel sublevers in front of a vertical plane cutting the set of type-bars near their pivotal axes, said system being equal in width to the set of type-bars, and the sublevers of said system having their pivotal axes at elevations progressively increasing from the middle to the sides of the system, a set of parallel key-levers, wider than the system of sublevers, a set of parallel angular levers above the key-levers and behind the sublevers, said set of angular levers being equal in width to the set of key-levers, and said angular levers having their pivotal axes at elevations progressively increasing from the middle to the sides of the set, parallel connections between the type-bars and sublevers, connections of gradually-increasing length from the center outward between the key-levers and angular levers, and links pivoted at their rear ends to the angular levers and at their front ends to the sublevers, the said links being more and more obliquely arranged from the middle of the system toward the sides thereof.

60. In a type-writing machine, the combination of a front-strike pivoted type-bar, a sublever supported in front of a vertical plane cutting the type-bar near its pivotal axis, said sublever having upper and lower arms, a key-actuated angular lever supported behind the vertical plane containing the axis of said sublever, a key-lever, a link extending backward from the upper arm of said sublever and connecting it with the type-bar, another link extending backward from the lower arm of said sublever and connecting it with the angular lever, and another link extending downward from the angular lever and connecting it with the key-lever.

61. In a type-writing machine, the combination of a set of front-strike pivoted type-bars, a set of key-levers wider than the set of type-bars, a system of sublevers having their pivotal axes at elevations progressively increasing from the middle to the sides of the system,

5 each of said sublevers being movable at its ends on arcs whose chords are more nearly horizontal than vertical, and said system of sublevers at the top being substantially equal in width to the set of type-bars, links pivoted to the upper arms of said sublevers and to the type-bars, and means connecting the lower arms of said sublevers with the key-levers.

Signed in the borough of Manhattan, city of New York, in the county of New York and State of New York, this 14th day of July, A. D. 1903. 10

JACOB FELBEL.

Witnesses:

K. V. DONOVAN,
M. F. HANNWEBER.