

(19) World Intellectual Property Organization  
International Bureau



(43) International Publication Date  
23 April 2009 (23.04.2009)

PCT

(10) International Publication Number  
WO 2009/052348 A2

- (51) International Patent Classification:  
G01N 27/26 (2006.01) B01J 19/08 (2006.01)
- (21) International Application Number:  
PCT/US2008/080264
- (22) International Filing Date: 17 October 2008 (17.10.2008)
- (25) Filing Language: English
- (26) Publication Language: English
- (30) Priority Data:  
60/980,782 17 October 2007 (17.10.2007) US
- (71) Applicants (for all designated States except US): **ADVANCED LIQUID LOGIC, INC.** [US/US]; PO Box 14025, Research Triangle Park, North Carolina 27709 (US). **ECKHARDT, Allen** [US/US]; 908 Kimball Drive, Durham, North Carolina 27705 (US).
- (72) Inventors; and
- (75) Inventors/Applicants (for US only): **SISTA, Ramakrishnan** [IN/US]; 2800 C Golden Horseshoe Circle, Morrisville, North Carolina 27560 (US). **PAMULA,**

**Vamsee** [IN/US]; 2807 Skybrook Lane, Durham, North Carolina 27703 (US). **SRINIVASAN, Vijay** [IN/US]; 2805 Skybrook Lane, Durham, North Carolina 27703 (US). **POLLACK, Michael** [US/US]; 1102 Hill Street, Durham, North Carolina 27709 (US).

(74) Agent: **MILLS, Eric**; Post Office Box 867, New Bern, North Carolina 28563-0867 (US).

(81) Designated States (unless otherwise indicated, for every kind of national protection available): AE, AG, AL, AM, AO, AT, AU, AZ, BA, BB, BG, BH, BR, BW, BY, BZ, CA, CH, CN, CO, CR, CU, CZ, DE, DK, DM, DO, DZ, EC, EE, EG, ES, FI, GB, GD, GE, GH, GM, GT, HN, HR, HU, ID, IL, IN, IS, JP, KE, KG, KM, KN, KP, KR, KZ, LA, LC, LK, LR, LS, LT, LU, LY, MA, MD, ME, MG, MK, MN, MW, MX, MY, MZ, NA, NG, NI, NO, NZ, OM, PG, PH, PL, PT, RO, RS, RU, SC, SD, SE, SG, SK, SL, SM, ST, SV, SY, TJ, TM, TN, TR, TT, TZ, UA, UG, US, UZ, VC, VN, ZA, ZM, ZW.

(84) Designated States (unless otherwise indicated, for every kind of regional protection available): ARIPO (BW, GH,

[Continued on next page]

(54) Title: MANIPULATION OF BEADS IN DROPLETS

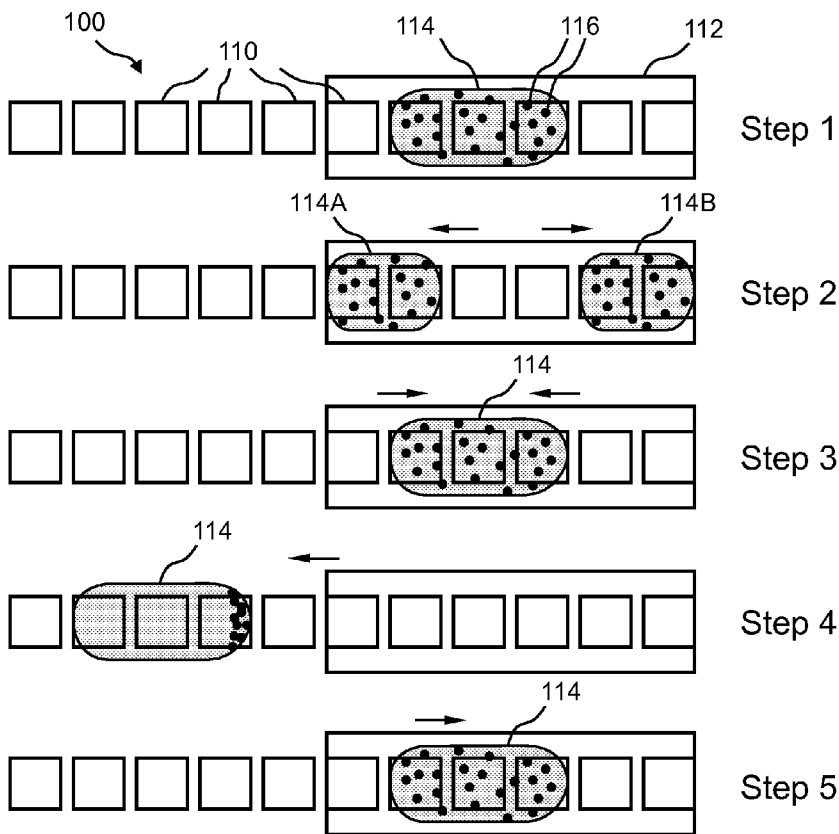

Figure 1

(57) Abstract: The invention provides a method of dispersing or circulating magnetically responsive beads within a droplet in a droplet actuator. The invention, in one embodiment, makes use of a droplet actuator with a plurality of droplet operations electrodes configured to transport the droplet, and a magnet field present at a portion of the plurality of droplet operations electrodes. A bead bead-containing droplet is provided on the droplet actuator in the presence of the uniform magnetic field. Beads are circulated in the droplet during incubation by conducting droplet operations on the droplet within a uniform region of the magnetic field. Other embodiments are also provided.

WO 2009/052348 A2



GM, KE, LS, MW, MZ, NA, SD, SL, SZ, TZ, UG, ZM, ZW), Eurasian (AM, AZ, BY, KG, KZ, MD, RU, TJ, TM), European (AT, BE, BG, CH, CY, CZ, DE, DK, EE, ES, FI, FR, GB, GR, HR, HU, IE, IS, IT, LT, LU, LV, MC, MT, NL, NO, PL, PT, RO, SE, SI, SK, TR), OAPI (BF, BJ, CF, CG, CI, CM, GA, GN, GQ, GW, ML, MR, NE, SN, TD, TG).

**Published:**

— *without international search report and to be republished upon receipt of that report*

## Manipulation of Beads in Droplets

### 1 Government Interest

This invention was made with government support under DK066956-02 and CA114993-01A2 awarded by the National Institutes of Health. The United States Government has certain rights in the invention.

### 2 Related Application

This application claims priority to U.S. Patent Application No. 60/980,782, filed on October 17, 2007, the entire disclosure of which is incorporated herein by reference.

### 3 Background

Droplet actuators are used to conduct a wide variety of droplet operations. A droplet actuator typically includes two substrates separated by a gap. The substrates include electrodes for conducting droplet operations. The space is typically filled with a filler fluid that is immiscible with the fluid that is to be manipulated on the droplet actuator. The formation and movement of droplets is controlled by electrodes for conducting a variety of droplet operations, such as droplet transport and droplet dispensing. There is a need for improvements to droplet actuators that facilitate handling of droplets with beads.

### 4 Summary of the Invention

The invention provides a method of dispersing or circulating magnetically responsive beads within a droplet in a droplet actuator. The invention, in one embodiment, makes use of a droplet actuator with a plurality of droplet operations electrodes configured to transport the droplet, and a magnet field present at a portion of the plurality of droplet operations electrodes. A bead containing droplet is provided on the droplet actuator in the presence of the uniform magnetic field. Beads are circulated in the droplet during incubation by conducting droplet operations on the droplet within a uniform region of the magnetic field. Other aspects of the invention will be apparent from the ensuing description of the invention.

## 5 Definitions

As used herein, the following terms have the meanings indicated.

“Activate” with reference to one or more electrodes means effecting a change in the electrical state of the one or more electrodes which results in a droplet operation.

“Bead,” with respect to beads on a droplet actuator, means any bead or particle that is capable of interacting with a droplet on or in proximity with a droplet actuator. Beads may be any of a wide variety of shapes, such as spherical, generally spherical, egg shaped, disc shaped, cubical and other three dimensional shapes. The bead may, for example, be capable of being transported in a droplet on a droplet actuator or otherwise configured with respect to a droplet actuator in a manner which permits a droplet on the droplet actuator to be brought into contact with the bead, on the droplet actuator and/or off the droplet actuator. Beads may be manufactured using a wide variety of materials, including for example, resins, and polymers. The beads may be any suitable size, including for example, microbeads, microparticles, nanobeads and nanoparticles. In some cases, beads are magnetically responsive; in other cases beads are not significantly magnetically responsive. For magnetically responsive beads, the magnetically responsive material may constitute substantially all of a bead or one component only of a bead. The remainder of the bead may include, among other things, polymeric material, coatings, and moieties which permit attachment of an assay reagent. Examples of suitable magnetically responsive beads are described in U.S. Patent Publication No. 2005-0260686, entitled, “Multiplex flow assays preferably with magnetic particles as solid phase,” published on November 24, 2005, the entire disclosure of which is incorporated herein by reference for its teaching concerning magnetically responsive materials and beads. The fluids may include one or more magnetically responsive and/or non-magnetically responsive beads. Examples of droplet actuator techniques for immobilizing magnetically responsive beads and/or non-magnetically responsive beads and/or conducting droplet operations protocols using beads are described in U.S. Patent Application No. 11/639,566, entitled “Droplet-Based Particle Sorting,” filed on December 15, 2006; U.S. Patent Application No. 61/039,183, entitled “Multiplexing Bead Detection in a Single Droplet,” filed on March 25, 2008; U.S. Patent Application No. 61/047,789, entitled “Droplet Actuator Devices and Droplet Operations Using Beads,” filed on April 25, 2008; U.S. Patent Application No. 61/086,183, entitled “Droplet Actuator Devices and Methods for Manipulating Beads,” filed on August 5, 2008; International Patent Application No. PCT/US2008/053545, entitled “Droplet Actuator Devices and Methods Employing Magnetically responsive beads,” filed on February 11,

2008; International Patent Application No. PCT/US2008/058018, entitled “Bead-based Multiplexed Analytical Methods and Instrumentation,” filed on March 24, 2008; International Patent Application No. PCT/US2008/058047, “Bead Sorting on a Droplet Actuator,” filed on March 23, 2008; and International Patent Application No. PCT/US2006/047486, entitled “Droplet-based Biochemistry,” filed on December 11, 2006; the entire disclosures of which are incorporated herein by reference.

“Droplet” means a volume of liquid on a droplet actuator that is at least partially bounded by filler fluid. For example, a droplet may be completely surrounded by filler fluid or may be bounded by filler fluid and one or more surfaces of the droplet actuator. Droplets may, for example, be aqueous or non-aqueous or may be mixtures or emulsions including aqueous and non-aqueous components. Droplets may take a wide variety of shapes; nonlimiting examples include generally disc shaped, slug shaped, truncated sphere, ellipsoid, spherical, partially compressed sphere, hemispherical, ovoid, cylindrical, and various shapes formed during droplet operations, such as merging or splitting or formed as a result of contact of such shapes with one or more surfaces of a droplet actuator.

“Droplet Actuator” means a device for manipulating droplets. For examples of droplets, see U.S. Patent 6,911,132, entitled “Apparatus for Manipulating Droplets by Electrowetting-Based Techniques,” issued on June 28, 2005 to Pamula et al.; U.S. Patent Application No. 11/343,284, entitled “Apparatuses and Methods for Manipulating Droplets on a Printed Circuit Board,” filed on January 30, 2006; U.S. Patents 6,773,566, entitled “Electrostatic Actuators for Microfluidics and Methods for Using Same,” issued on August 10, 2004 and 6,565,727, entitled “Actuators for Microfluidics Without Moving Parts,” issued on January 24, 2000, both to Shenderov et al.; Pollack et al., International Patent Application No. PCT/US2006/047486, entitled “Droplet-Based Biochemistry,” filed on December 11, 2006, the disclosures of which are incorporated herein by reference. Methods of the invention may be executed using droplet actuator systems, e.g., as described in International Patent Application No. PCT/US2007/009379, entitled “Droplet manipulation systems,” filed on May 9, 2007. In various embodiments, the manipulation of droplets by a droplet actuator may be electrode mediated, e.g., electrowetting mediated or dielectrophoresis mediated.

“Droplet operation” means any manipulation of a droplet on a droplet actuator. A droplet operation may, for example, include: loading a droplet into the droplet actuator; dispensing one or more droplets from a source droplet; splitting, separating or dividing a droplet into two or more

droplets; transporting a droplet from one location to another in any direction; merging or combining two or more droplets into a single droplet; diluting a droplet; mixing a droplet; agitating a droplet; deforming a droplet; retaining a droplet in position; incubating a droplet; heating a droplet; vaporizing a droplet; condensing a droplet from a vapor; cooling a droplet; disposing of a droplet; transporting a droplet out of a droplet actuator; other droplet operations described herein; and/or any combination of the foregoing. The terms “merge,” “merging,” “combine,” “combining” and the like are used to describe the creation of one droplet from two or more droplets. It should be understood that when such a term is used in reference to two or more droplets, any combination of droplet operations sufficient to result in the combination of the two or more droplets into one droplet may be used. For example, “merging droplet A with droplet B,” can be achieved by transporting droplet A into contact with a stationary droplet B, transporting droplet B into contact with a stationary droplet A, or transporting droplets A and B into contact with each other. The terms “splitting,” “separating” and “dividing” are not intended to imply any particular outcome with respect to size of the resulting droplets (i.e., the size of the resulting droplets can be the same or different) or number of resulting droplets (the number of resulting droplets may be 2, 3, 4, 5 or more). The term “mixing” refers to droplet operations which result in more homogenous distribution of one or more components within a droplet. Examples of “loading” droplet operations include microdialysis loading, pressure assisted loading, robotic loading, passive loading, and pipette loading. In various embodiments, the droplet operations may be electrode mediated, e.g., electrowetting mediated or dielectrophoresis mediated.

“Filler fluid” means a fluid associated with a droplet operations substrate of a droplet actuator, which fluid is sufficiently immiscible with a droplet phase to render the droplet phase subject to electrode-mediated droplet operations. The filler fluid may, for example, be a low-viscosity oil, such as silicone oil. Other examples of filler fluids are provided in International Patent Application No. PCT/US2006/047486, entitled, “Droplet-Based Biochemistry,” filed on December 11, 2006; and in International Patent Application No. PCT/US2008/072604, entitled “Use of additives for enhancing droplet actuation,” filed on August 8, 2008.

“Immobilize” with respect to magnetically responsive beads, means that the beads are substantially restrained in position in a droplet or in filler fluid on a droplet actuator. For example, in one embodiment, substantially immobilized beads are sufficiently restrained in position to permit execution of a splitting operation on a droplet, yielding one droplet with substantially all of the beads and one droplet substantially lacking in the beads.

“Magnetically responsive” means responsive to a magnetic field. “Magnetically responsive beads” include or are composed of magnetically responsive materials. Examples of magnetically responsive materials include paramagnetic materials, ferromagnetic materials, ferrimagnetic materials, and metamagnetic materials. Examples of suitable paramagnetic materials include iron, nickel, and cobalt, as well as metal oxides, such as  $\text{Fe}_3\text{O}_4$ ,  $\text{BaFe}_{12}\text{O}_{19}$ ,  $\text{CoO}$ ,  $\text{NiO}$ ,  $\text{Mn}_2\text{O}_3$ ,  $\text{Cr}_2\text{O}_3$ , and  $\text{CoMnP}$ .

“Washing” with respect to washing a magnetically responsive bead means reducing the amount and/or concentration of one or more substances in contact with the magnetically responsive bead or exposed to the magnetically responsive bead from a droplet in contact with the magnetically responsive bead. The reduction in the amount and/or concentration of the substance may be partial, substantially complete, or even complete. The substance may be any of a wide variety of substances; examples include target substances for further analysis, and unwanted substances, such as components of a sample, contaminants, and/or excess reagent. In some embodiments, a washing operation begins with a starting droplet in contact with a magnetically responsive bead, where the droplet includes an initial amount and initial concentration of a substance. The washing operation may proceed using a variety of droplet operations. The washing operation may yield a droplet including the magnetically responsive bead, where the droplet has a total amount and/or concentration of the substance which is less than the initial amount and/or concentration of the substance. Other embodiments are described elsewhere herein, and still others will be immediately apparent in view of the present disclosure.

The terms “top” and “bottom” are used throughout the description with reference to the top and bottom substrates of the droplet actuator for convenience only, since the droplet actuator is functional regardless of its position in space.

When a liquid in any form (e.g., a droplet or a continuous body, whether moving or stationary) is described as being “on”, “at”, or “over” an electrode, array, matrix or surface, such liquid could be either in direct contact with the electrode/array/matrix/surface, or could be in contact with one or more layers or films that are interposed between the liquid and the electrode/array/matrix/surface.

When a droplet is described as being “on” or “loaded on” a droplet actuator, it should be understood that the droplet is arranged on the droplet actuator in a manner which facilitates using the droplet actuator to conduct one or more droplet operations on the droplet, the droplet is

arranged on the droplet actuator in a manner which facilitates sensing of a property of or a signal from the droplet, and/or the droplet has been subjected to a droplet operation on the droplet actuator.

## 6 Description

The invention provides droplet actuators having specialized configurations for manipulation of droplets including beads and/or for manipulation of beads in droplets. In certain embodiments, the droplet actuators of the invention include magnets and/or physical barriers manipulation of droplets including beads and/or for manipulation of beads in droplets. The invention also includes methods of manipulating of droplets including beads and/or for manipulation of beads in droplets, as well as methods of making and using the droplet actuators of the invention. The droplet actuators of the invention are useful for, among other things, conducting assays for qualitatively and/or quantitatively analyzing one or more components of a droplet. Examples of such assays include affinity based assays, such as immunoassays; enzymatic assays; and nucleic acid assays. Other aspects of the invention will be apparent from the ensuing discussion.

### 6.1 Incubation of Beads

In certain embodiments, the invention provides droplet actuators and methods for incubating beads. For example, a sample including bead-containing antibodies may be incubated on the droplet actuator in order to permit one or more target components to bind to the antibodies. Examples of target components include analytes; contaminants; cells, such as bacteria and protozoa; tissues; and organisms, such as multicellular parasites. In the presence of a magnet, magnetic beads in the droplet may be substantially immobilized and may fail to circulate throughout the droplet. The invention provides various droplet manipulations during incubation of droplets on a droplet actuator in order to increase circulation of beads within the droplet and/or circulation of droplet contents surrounding beads. It will be appreciated that in the various embodiments described below employing magnetically responsive beads, beads that are not substantially magnetically responsive may also be included in the droplets.

**Figure 1** illustrates techniques that are useful process of incubating a droplet including magnetically responsive beads. Among other things, the techniques are useful for enhancing circulation of fluids and beads within the droplet during an incubation step.



In Figure 1, each step is illustrated on a path of electrodes 110. A magnet 112 is associated with a subset of electrodes 110. Magnet 112 is arranged relative to the electrodes 110 such that a subset of electrodes 110 are within a uniform region of the magnetic field produced by magnet 112. Bead clumping is reduced when the droplet is present in this uniform region.

In Step 1, droplet 116 is located atop magnet 112. Beads 116 are substantially immobilized in a distributed fashion adjacent to the droplet operations surface. The beads are generally less clumped than they would be in the presence of a non-uniform region of the magnetic field. In Step 2 droplet 114 is split using droplet operations into two sub-droplets 114A, 114B. During the splitting operation beads and liquid are circulated within the droplets 114, 114A and 114B. In Step 3 Droplets 114A and 114B are merged using droplet operations into a single droplet 114. This merging operation is accomplished within the uniform region of the magnetic field. During the merging operation beads and liquid are further circulated within the droplets 114, 114A and 114B.

In Step 4, droplet 114 is transported using droplet operations along electrodes 110 away from the magnet 112. As droplet 116 moves away from magnet 110, beads 116 are pulled to the edge of droplet 114 that nearest the magnet 112. Movement of beads 116 within droplet 114 provides further beneficial circulation of beads and liquid within the droplet 114. In Step 5, droplet 116 is transported using droplet operations back to the step 1 position. Beads 116 within the droplet 116 are again dispersed in the presence of the uniform magnetic field of magnet 112. This redistribution of beads, as droplet 114 returns to its position within the uniform region of the magnetic field provides further beneficial circulation of beads and liquid within the droplet 114.

These steps may be conducted in any logical order. Each step may be conducted any number of times between the other steps. For example, Steps 1-3 may be repeated multiple times before moving onto Step 4. Similarly, Steps 3-5 may be repeated multiple times before returning to Steps 1-3. Moreover, all steps are not required. For example, in one embodiment, an incubation step in an assay is accomplished by repeating Steps 1-3. In another embodiment, an incubation step in an assay is accomplished by repeating Steps 3-5.

The incubation method of the invention is useful for enhancing circulation of magnetically responsive beads with the liquid in a droplet while the droplet remains in the presence of a magnetic field. Among other advantages, the approach may reduce bead clumping and permit tighter droplet actuator designs making more efficient use of droplet actuator real estate.

In one embodiment, the invention provides a droplet operations incubation scheme, that does not allow magnetically responsive beads to be introduced into a region of the magnetic field which is sufficiently non-uniform to cause bead clumping. In another embodiment, the invention provides a merge-and-split incubation scheme, that does not allow magnetically responsive beads to be introduced into a region of the magnetic field which is sufficiently non-uniform to cause bead clumping. In yet another embodiment, the invention provides a droplet transport incubation scheme, that does not allow magnetically responsive beads to be introduced into a region of the magnetic field which is sufficiently non-uniform to cause bead clumping.

Any combination of droplet operations which result in effective mixing (e.g., substantially complete mixing) may be chosen. Mixing is complete when it is sufficient for conducting the analysis being undertaken. The droplet may be oscillated in the presence of the uniform region of the magnetic field by transporting the droplet back and forth within the uniform region. In some cases, electrode sizes used for the oscillation may be varied to increase circulation within the droplet. In some cases, droplet operations electrodes are used to effect droplet operations to transport a droplet back and forth or in one or more looping patterns. Preferably the oscillation pattern does not allow to be introduced into a region of the magnetic field which is sufficiently uniform to cause bead clumping.

In some cases, droplet operations are performed at an edge of the magnet to more equally redistribute the magnetically responsive beads. In some cases, droplet operations are performed performed away from the magnet, followed by transporting the droplet.

**Figure 2** illustrates another process of incubation of antibodies, wherein a sample and magnetically responsive beads are provided within the magnet field of a magnet, e.g., within a uniform magnetic field region of a magnet. Figure 2 shows a top view of a portion of droplet actuator 100 that is described in Figure 1.

In Step 1, beads 116 are substantially immobilized along the surface of the droplet operations electrodes 110 due to the magnetic field of the magnet 112. In Step 2, droplet 114 is split using droplet operations into two droplets 118, both remaining in the uniform region of the magnetic field. In step 4, the two droplets 118 are transported away from the magnet 112, thereby attracting the beads 116 to the edge of the two droplets 118 nearest the magnet 112. This operation causes flow reversal within the droplets 118, which enhances effective mixing. The two droplets 118 may alternatively be transported away from the magnet in different directions,

such as in opposite directions. In Step 4 the two droplets 118 are merged into one droplet 116. In step 5, the droplet 116 is transported back to the step 1 position, causing the beads 116 to disperse within the droplet 116.

**Figure 3** illustrates another process of incubation of magnetically responsive beads within a droplet, wherein a sample and magnetically responsive beads are subjected to droplet operations within the magnet field of a magnet. Figure 3 shows a top view of a portion of a droplet actuator 300 that includes a set of droplet operations electrodes 310 (e.g., electrowetting electrodes) that is arranged in sufficient proximity to a magnet, such that a droplet 314 moving along the droplet operations electrodes 310 is within the magnet field of the magnet, e.g., a region of uniform magnetic field. For example, the set of droplet operations electrodes 310 are arranged in a closed loop and in the presence of two magnets, such as a magnet 312A and magnet 312B, as shown in Figure 3. In this embodiment, the droplet 314 may include sample and beads 316, and some or all of the beads may be magnetically responsive.

In Step 1, sample with beads 316 in the droplet 314 is provided on droplet actuator. Beads 316 are substantially immobilized along the surface of the droplet operations electrodes 310 due to the magnetic field of the first magnet 312A that is located at "lane A" of the electrode loop. In Step 2, the droplet 314 is split using droplet operations into two droplets 318, distributing the beads 316 in the two droplets 318 at "lane A" of the electrode loop. In Step 3, the two droplets 318 are transported using droplet operations in opposite directions away from the first magnet 312A at "lane A" and toward the second magnet 312B that is located at "lane B" of the electrode loop. In Step 4, in the presence of the second magnet 312B at "lane B," droplets 318 are merged into one droplet 320.

In Steps 5-6, not shown, the process of steps 1-3 may be essentially repeated in reverse. In step 5, droplet 320 may be split into two droplets 318, distributing the beads 316 in the two droplets 318 at "lane B." In Step 6, droplets 318 are transported in opposite directions away from the second magnet 312B at "lane B" and back to the first magnet 312A at "lane A." In Step 7, in the presence of the first magnet 312A at "lane A," droplets 318 are merged into one droplet 320.

The droplet split and merge operation as described above provide efficient dispersion of beads in the presence of a magnet, thereby improving the efficiency of the binding of antibodies and the analyte. The various droplet operations may be conducted in primarily or completely in uniform regions of the magnetic fields generated by magnets 312A, 312B. Alternatively, the droplet split

and merge operation as described above may be performed away from the magnet and/or near the edge of the magnet.

## 6.2 Magnet Configurations

**Figure 4** illustrates a method of shielding the effect of multiple magnets in a droplet actuator 400 by using a magnetic shielding material, preferably one that has high magnetic permeability. One example of such material is Mu-metal foil. Mu-metal is a nickel-iron alloy (e.g., 75% nickel, 15% iron, plus copper and molybdenum) that has very high magnetic permeability. Figure 4 shows a top view of multiple washing lanes 410, wherein each washing lane 410 includes a string of droplet operations electrodes 412 in the presence of a magnet 414. An electrode array 416 (e.g., an array of electrowetting electrodes) for performing droplet operations feed the multiple washing lanes 410. Additionally, the droplets 418 that are transported may include magnetically responsive beads (not shown). Furthermore, this embodiment provides a magnetic shield 420, provided as a layer that is beneath the electrode array 416.

Because of the presence of multiple magnets 414, which are used to immobilize magnetically responsive beads during washing, the magnetically responsive beads in the reservoir tend to become aggregated, sometimes irreversibly. When bead-containing droplets are dispensed using droplet operations, bead aggregation may cause the number of beads that are present in each dispensed droplet to vary. Variation in bead dispensing may affect the assay result, which is not desirable. The invention, as shown in Figure 4, provides magnetic shield 420 in the area under the electrode array 416 of the droplet actuator 400. The magnetic shield 420 may be formed of alloys, such as Mu-metal foil, which shields the magnetically responsive beads within the electrode array 416 from stray magnetic fields 422.

**Figure 5** illustrates a magnet array 500 for performing multiple immunoassays that has reduced, preferably substantially no, interference due to adjacent magnets within a droplet actuator (not shown) having a substrate associated with droplet operations electrodes. The electrodes are arranged for conducting one or more droplet operations on a droplet operations surface of the substrate. Magnets, such as the magnet array 500 shown in Figure 5, may be arranged with respect to the droplet actuator such that one or more magnets cancels out some portion of a magnetic field of one or more other magnets. In this manner, an area of the surface may have some portions that are subject to magnetic fields and some portions in which the magnetic fields have been cancelled out. For example, magnets may be arranged to cancel the field in areas of

the droplet actuator that includes liquid along with magnetically responsive beads. Specifically reservoirs, incubation regions, detection regions are preferably in regions in which the magnetic fields have been cancelled out.

In one embodiment, the arrangement involves an array of alternately placed magnets, e.g., as shown in Figure 5. In general, magnets may be located in any position which supplies a magnetic field to the vicinity of the droplet operations surface where the magnetic field is desired and eliminates or weakens the magnetic field in other areas where the magnetic field is not desired. In one embodiment, a first magnet produces a first magnetic field where it is desirable to immobilize magnetically responsive beads in a droplet, while a second magnet produces a second magnetic field which cancels or weakens a portion of the first magnetic field. This arrangement produces a device in which a portion of the droplet operations surface that would have otherwise been influenced by the first magnetic field is subjected to a weak or absent field because the first magnetic field has been cancelled or weakened by the second magnetic field.

In one embodiment, one or more of the magnets is fixed in relation to the droplet operations surface, and the invention comprises conducting one or more droplet operations using droplets that contain magnetically responsive beads, where the droplets are in proximity to one or more magnets and are in the presence or absence of a magnetic field.

In another embodiment, the magnetic field exerts sufficient influence over magnetically responsive beads that the droplets may be substantially immobile during one droplet operation, such as a splitting operation, and yet not so stable that the droplets are restrained from being transported away from the magnetic field with the magnet. In this embodiment, the droplet may be surrounded by a filler fluid, and yet the droplet with the magnetically responsive beads may be transported away from the magnetic with substantially no loss of magnetically responsive beads to the filler fluid.

**Figure 6** illustrates simulation results 600 that show the surface field of 2 columns of magnet array 500 of Figure 5.

### **6.3 Resuspension of Beads within a Reservoir**

**Figure 7** illustrates a process of resuspension of beads (e.g., magnetically-responsive beads) within a reservoir configured with multiple electrodes within the. Figure 7 shows a top view of a

portion of a droplet actuator 700 that includes a reservoir 710 that is formed of multiple electrodes (e.g., electrodes 1 through 9 in a 3 x 3 array), whereby the reservoir 710 feeds a line of droplet operations electrodes 712 (e.g., electrowetting electrodes) to which droplets that contain beads may be dispensed.

Referring to Figure 7, a process of resuspension of beads within a reservoir by having multiple electrodes within the same reservoir may include, but is not limited to, the following steps. In Step 1, beads 714 are aggregated within the solution 716 due to the presence of multiple magnets (not shown). In Step 2, electrodes within the reservoir 710 are used to subject the solution 716 to droplet operations, thereby resuspension of the beads 714. The electrode activation sequence may be randomized to create more chaotic flow fields for more efficient resuspension. The liquid may be split and merged and subjected to other droplet operations.

During the above-described process, the electrode activation sequence may be chosen such that the beads are mixed well by means of droplet operations. Additionally, when dispensing (e.g., pulling out a finger of fluid) a bead droplet from the electrode array of the reservoir, all the electrodes within the reservoir may be switched ON and OFF at the same time, depending on the requirement. It should be noted that an almost infinite variety of electrode shapes is possible. Any shape which is capable of facilitating a droplet operation will suffice.

The resuspension process may be repeated between every 1, 2, 3, 4, 5 or more droplet dispensing operations. The resuspend-and-dispense pattern may be adjusted as required based on the specific characteristics of bead types and droplet compositions. For example, in one embodiment, the process of the invention results in dispensing bead-containing droplets with less than 95% variability in bead count. In another embodiment, the process of the invention results in dispensing bead-containing droplets with less than 99% variability in bead count. In another embodiment, the process of the invention results in dispensing bead-containing droplets with less than 99.9% variability in bead count. In another embodiment, the process of the invention results in dispensing bead-containing droplets with less than 99.99% variability in bead count.

**Figure 8** illustrates a process of resuspending beads (e.g., magnetically-responsive beads) within a reservoir by pushing out a finger of liquid and then merging back. Figure 8 shows a top view of a portion of a droplet actuator 800 that includes a reservoir 810 that feeds a line of droplet operations electrodes 812 (e.g., electrowetting electrodes) to which droplets that contain beads may be dispensed. Additionally, the reservoir includes a solution 814 that includes beads 816.

Referring to Figure 8, a process of resuspension of beads within a reservoir by pushing out a finger of liquid and then merging back may include, but is not limited to, the following steps.

In Step 1, beads 816 are aggregated within the solution 814 due to the presence of multiple magnets (not shown). In Step 2, a finger of solution 814 that includes beads 816 is pulled out of the reservoir 810 using droplet operations. In Step 3, a 2X slug 818 is dispensed by splitting the middle of the finger of solution 814. In Step 4, the 2X slug 818 is merged back with the solution 814 that includes magnetically responsive beads 816 within the reservoir 810.

Steps 2 through 4 may be repeated until the desired degree of resuspension is achieved, e.g., until substantially completely resuspended beads are obtained within the bead solution of the reservoir 810. When the desired degree of resuspension is achieved, bead-containing droplets may be dispensed, achieving a target percentage of variation in each droplet.

The resuspension process may be repeated between every 1, 2, 3, 4, 5 or more droplet dispensing operations. The resuspend-and-dispense pattern may be adjusted as required based on the specific characteristics of bead types and droplet compositions. For example, in one embodiment, the process of the invention results in dispensing bead-containing droplets with less than 95% variability in bead count. In another embodiment, the process of the invention results in dispensing bead-containing droplets with less than 99% variability in bead count. In another embodiment, the process of the invention results in dispensing bead-containing droplets with less than 99.9% variability in bead count. In another embodiment, the process of the invention results in dispensing bead-containing droplets with less than 99.99% variability in bead count.

**Figure 9** illustrates a reservoir in which beads are resuspended by applying high frequency voltage to the reservoir electrode. The figure shows a top view of a portion of droplet actuator 800 of Figure 8. Reservoir 810 includes a droplet 814 that includes magnetically responsive beads 816. Beads 816 in a reservoir 810 may tend to become aggregated due to, for example, the presence of nearby magnets (not shown). Aggregation may adversely affect bead count in dispensed beads, adversely impacting reliability of assay results for assays conducted using the dispensed bead-containing droplets. Beads 816 may be resuspended within the magnetically responsive bead solution within the reservoir 810 by applying a high frequency AC voltage to the reservoir electrode 810, in accordance with the invention. Because of the high frequency AC voltage, the magnetically responsive beads 816 tend to oscillate because of the wetting and dewetting of the contact line of the droplet. This oscillation at the periphery disperses the

magnetically responsive beads 816 and resuspends them in the supernatant. In one example, the high frequency AC voltage may be in the range from about 100 volts to about 300 volts with a frequency from about 10 Hz to about 1000 Hz.

The resuspension process may be repeated between every 1, 2, 3, 4, 5 or more droplet dispensing operations. The resuspend-and-dispense pattern may be adjusted as required based on the specific characteristics of bead types and droplet compositions. For example, in one embodiment, the process of the invention results in dispensing bead-containing droplets with less than 95% variability in bead count. In another embodiment, the process of the invention results in dispensing bead-containing droplets with less than 99% variability in bead count. In another embodiment, the process of the invention results in dispensing bead-containing droplets with less than 99.9% variability in bead count. In another embodiment, the process of the invention results in dispensing bead-containing droplets with less than 99.99% variability in bead count.

#### **6.4 Improving Dispersion of Magnetically Responsive beads by Magnet Configurations**

**Figure 10** illustrates a side view of a droplet actuator 1000 that includes a top substrate 1010 and bottom substrate 1012 that are separated by a gap. A set of droplet operations electrodes 1014 (e.g., electrowetting electrodes) is provided on the bottom substrate 1012. Additionally, a first electromagnet 1016 is arranged near the top substrate 1010 and a second electromagnet 1018 is arranged near the bottom substrate 1012. The proximity of the electromagnets 1016 and 1018 to the droplet actuator 1000 is sufficiently close that the gap is within the magnetic fields thereof. A droplet 1020 that includes magnetically responsive beads 1022 is in the gap and may be manipulated along the droplet operations electrodes 1014.

Electromagnets 1016 and 1018 may be used to improve dispersion of magnetically responsive beads 1022. Improved dispersion may, for example, to improve binding efficiency of antibodies and analytes to the surface of the beads. By providing an electromagnet on the top and bottom of the droplet 1020, the magnetically responsive beads 1022 may be effectively dispersed within the droplet 1020 by switching ON and OFF the magnetic fields of electromagnets 1016 and 1018. In one example, Figure 10A shows the electromagnet 1016 turned ON and the electromagnet 1018 turned OFF, which causes the beads 1022 to be attracted to the electromagnet 1016 and are, therefore, pulled to the electromagnet 1016 side of the droplet 1020. Subsequently, electromagnet 1018 is turned ON and electromagnet 1016 is turned OFF, which causes the beads



1022 to be attracted to electromagnet 1018 and are, therefore, pulled to the electromagnet 1018 side of the droplet 1020. Alternating the activation of electromagnets 1016 and 1018 may be repeated until resuspension of the beads 1022 is substantially achieved. Figure 10B shows both electromagnets 1016 and 1018 turned ON at the same time, which causes a pillar of beads 1022 to form through droplet 1020. Various changes in the configuration of magnet activation (ON/ON, ON/OFF, OFF/ON, and OFF/OFF) may be used to circulate magnetically responsive beads 1022 within droplet 1020. In some embodiments, the pattern of magnet activation may be randomized. Examples include ON/OFF, OFF/ON, ON/OFF, OFF/ON, ON/OFF, etc.; ON/ON, ON/OFF, OFF/ON, ON/ON, ON/OFF, OFF/ON, ON/ON, ON/OFF, OFF/ON, etc.; ON/ON, ON/OFF, OFF/ON, OFF/OFF, ON/ON, ON/OFF, OFF/ON, OFF/OFF, ON/ON, ON/OFF, OFF/ON, OFF/OFF, etc.; ON/OFF, OFF/OFF, OFF/ON, OFF/OFF, ON/OFF, OFF/OFF, OFF/ON, OFF/OFF, ON/OFF, OFF/OFF, OFF/ON, OFF/OFF, etc. Various other magnet activation patterns will be apparent to one of skill in the art in light of the present specification.

**Figure 11** illustrates a side view of a droplet actuator 1100 including a top substrate 1110 and bottom substrate 1112 that are separated by a gap. A set of droplet operations electrodes 1114 (e.g., electrowetting electrodes) is provided on the bottom substrate 1112. Additionally, multiple magnets 1116 are arranged near the top substrate 1110 and multiple magnets 1116 are arranged near the bottom substrate 1112. In one example, magnets 1116-1, 1116-3, and 1116-5 are arranged near the top substrate 1110 and magnets 1116-2, 1116-4, and 1116-6 are arranged near the bottom substrate 1112. The proximity of the magnets 1116 to the droplet actuator 1100 is sufficiently close that the gap is within the magnetic fields thereof. A slug of liquid 1118 (e.g., antibodies sample mixture) that includes magnetically responsive beads 1120 is in the gap along the droplet operations electrodes 1114. This aspect of the invention may improve the binding of analytes or other target substances, such as cells, with antibodies that are present on the beads 1120.

Referring to Figure 11, a process of providing improved dispersion of magnetically responsive beads by use of a magnet arrangement, such as shown in Figure 11, may include, but is not limited to, the following steps.

Step 1: Magnet 1116-1=OFF, magnet 1116-2=ON, magnet 1116-3=OFF, magnet 1116-4=OFF, magnet 1116-5=OFF, and magnet 1116-6=OFF, which causes the magnetically responsive beads 1120 to be attracted toward magnet 1116-2.

Step 2: Magnet 1116-1=OFF, magnet 1116-2=OFF, magnet 1116-3=ON, magnet 1116-4=OFF, magnet 1116-5=OFF, and magnet 1116-6=OFF, which causes the magnetically responsive beads 1120 to be attracted toward magnet 1116-3.

Step 3 (not shown): Magnet 1116-1=OFF, magnet 1116-2=OFF, magnet 1116-3=OFF, magnet 1116-4=OFF, magnet 1116-5=OFF, and magnet 1116-6= ON, which causes the magnetically responsive beads 1120 to be attracted toward magnet 1116-6.

Step 4 (not shown): Magnet 1116-1=OFF, magnet 1116-2=OFF, magnet 1116-3=OFF, magnet 1116-4=OFF, magnet 1116-5= ON, and magnet 1116-6=OFF, which causes the magnetically responsive beads 1120 to be attracted toward magnet 1116-5.

Step 5 (not shown): Magnet 1116-1=OFF, magnet 1116-2=OFF, magnet 1116-3=OFF, magnet 1116-4=ON, magnet 1116-5=OFF, and magnet 1116-6=OFF, which causes the magnetically responsive beads 1120 to be attracted toward magnet 1116-4.

Step 6 (not shown): Magnet 1116-1=ON, magnet 2=OFF, magnet 3=OFF, magnet 4=OFF, magnet 5=OFF, and magnet 6=OFF, which causes the magnetically responsive beads to be attracted toward magnet 1.

Steps 1 through 6 may be repeated until a desired degree of dispersion or circulation of magnetically responsive beads 1120 and liquid is achieved.

**Figure 12** illustrates a side view of a droplet actuator 1200 that includes a top substrate 1210 and bottom substrate 1212 that are separated by a gap. A set of droplet operations electrodes 1214 (e.g., electrowetting electrodes) is provided on the bottom substrate 1212. A droplet 1216 that includes magnetically responsive beads 1218 is provided in the gap and may be manipulated along the droplet operations electrodes 1214. Additionally, a first magnet 1220A is arranged near the top substrate 1210 and a second magnet 1220B is arranged near the bottom substrate 1212. The proximity of the magnets 1220A and 1220B to the droplet actuator 1200 is sufficiently close that the gap is within the magnetic fields thereof. However, the distance of the magnets 1220A and 1220B from the droplet actuator 1200 may be adjusted by, for example, a mechanical means, thereby adjusting the influence of the magnetic fields upon the magnetically responsive beads 1218.

Mechanical movement of the magnets 1220A and 1220B disperses or otherwise circulates magnetically responsive beads and liquids within the droplet. In one example, Figure 12A shows both magnets 1220A and 1220B in close proximity to the droplet actuator 1200, which causes a pillar of beads 1218 to form through the droplet 1216. In another example, Figure 12B shows the magnet 1220A only may be moved mechanically by a distance “x” where substantially no magnetic field of magnet 1220A reaches the magnetically responsive beads 1218 and, thus, the beads 1218 are attracted toward the magnet 1220B, thereby dispersing the beads 1218. In like manner, the magnet 1220B only may be moved mechanically by a distance “x” where substantially no magnetic field of magnet 1220B reaches the magnetically responsive beads 1218 and, thus, the beads are attracted toward the first magnet 1220A, thereby dispersing the beads 1218. By, for example, alternating the mechanical movement of the magnets, effective dispersion of magnetically responsive beads 1218 is substantially ensured. In some embodiments, both magnets are moved. Magnets may be oscillated to rapidly circulate beads and liquids within the droplet.

## 6.5 Improved Droplet Splitting by Magnet Configurations

**Figure 13** illustrates a process of asymmetrically splitting a droplet. Figure 13 shows a top view of a portion of a droplet actuator 1300 that includes a set of droplet operations electrodes 1310 (e.g., electrowetting electrodes) that is arranged in sufficient proximity to a magnet 1312, such that a droplet 1314 moving along the droplet operations electrodes 1310 is within the magnet field of the magnet 1312, e.g., a region of uniform magnetic field. In this embodiment, the droplet 1314 may include sample and beads 1316, and some or all of the beads 1316 may be magnetically responsive.

The process may include, without limitation, the following steps. In step 1, after immobilizing the magnetically responsive beads 1316 to a localized area in the presence of magnet 1312, droplet operations electrodes 1310 are activated to extend droplet 1314 into a 4x-slug of liquid that extends beyond the boundary of magnet 1312. In Step 2, droplet operations electrode 1310 is deactivated, and the next two droplet operations electrodes 1310 remain on, and a third droplet operations electrode is activated to provide the asymmetric split. The process may, for example, be employed in a merge-and-split bead washing protocol.

**Figure 14** illustrates a process employing a hydrophilic patch in a droplet splitting operation. Figure 14 shows a top view of a portion of a droplet actuator 1400 that includes a set of droplet

operations electrodes 1410 (e.g., electrowetting electrodes) arranged in sufficient proximity to a magnet 1412, such that a droplet moving along the droplet operations electrodes 1410 is within the magnet field of the magnet 1412, e.g., a region of uniform magnetic field. In this embodiment, the droplet may be may include sample and beads 1414, and some or all of the beads may be magnetically responsive.

The process may include, without limitation, the following steps. In Step 1, a small hydrophilic patch 1416, which is patterned on the top substrate (not shown) and opposite a certain droplet operations electrode 1410, immobilizes the aqueous slug 1418, and the magnet 1412 immobilizes the magnetically responsive beads 1414. In Step 2, a droplet splitting operation is executed (e.g., forming droplets 1420 and 1422). The hydrophilic patch 1416 ensures droplet splitting at the same point in relation to the droplet operations electrode 1410 that is downstream of the hydrophilic patch 1416. In this example, the magnetically responsive beads 1414 remain substantially immobilized in droplet 1422 by the magnet 1412 and droplet 1522 is substantially free of beads 1420. The process may, for example, be employed in a merge-and-split bead washing protocol.

**Figure 15** illustrates a process of using a magnetic strip that is integrated into the gasket material at the point of bead immobilization. Figure 15 shows a top view of a portion of a droplet actuator 1500 that includes a set of droplet operations electrodes 1510 (e.g., electrowetting electrodes) that is arranged in sufficient proximity to a magnetic strip 1512 that is integrated into the gasket material 1514 of the droplet actuator 1500, such that a droplet moving along the droplet operations electrodes 1510 is within the magnet field of the magnetic strip 1512, e.g., a region of uniform magnetic field. In this embodiment, the droplet may be may include sample and beads 1516, and some or all of the beads may be magnetically responsive.

The process may include, but is not limited to, the following steps. In Step 1, magnetic strip 1512 immobilizes the magnetically responsive beads 1516 in an aqueous slug 1518. In Step 2, a droplet splitting operation occurs (e.g., forming droplets 1520 and 1522), whereby the magnetically responsive beads 1516 remain substantially immobilized in droplet 1520 by the magnetic strip 1512 and droplet 1522 is substantially free of beads 1516. The process may, for example, be employed in a merge-and-split bead washing protocol.

## 6.6 Improved Droplet Splitting by Physical Barrier

**Figure 16** illustrates a process of facilitating consistent droplet splitting by use of a physical barrier in the droplet actuator. Figure 16 shows a side view of a droplet actuator 1600 that includes a top substrate 1610 and bottom substrate 1612 that are separated by a gap. A set of droplet operations electrodes 1614 (e.g., electrowetting electrodes) is provided on the bottom substrate 1612. Additionally, a magnet 1616 is arranged in sufficient proximity to the droplet operations electrodes 1614, such that a droplet moving along the droplet operations electrodes 1610 is within the magnet field of the magnet 1616, e.g., a region of uniform magnetic field. In this embodiment, the droplet may include sample and beads 1618, and some or all of the beads 1618 may be magnetically responsive. Additionally, the droplet actuator 1600 includes a physical barrier 1620 that is arranged as shown in Figure 16. The physical barrier 1620 is used to reduce the gap at the point of splitting, thereby assisting the droplet splitting operation. Additionally, because of the existence of the rigid barrier, consistent splitting may be obtained substantially at the same point. Further, the physical barrier 1620 may in some cases be substantially nonmagnetic.

The process may include, but is not limited to, the following steps. In Step 1, magnet 1612 immobilizes the magnetically responsive beads 1618 in, for example, an aqueous slug 1622. The aqueous slug 1622 is intersected by the physical barrier 1620, which reduces the gap. In Step 2, a droplet splitting operation occurs (e.g., forming droplets 1624 and 1626), whereby the magnetically responsive beads 1618 remain substantially immobilized by the magnet 1616 and the physical barrier 1620 is used to reduce the gap at the point of splitting, thereby assisting the droplet splitting operation. In this example, magnetically responsive beads 1618 remain substantially immobilized in droplet 1624 by the magnet 1612 and droplet 1626 is substantially free of beads 1618. For example, substantially all of the magnetically responsive beads 1618 may remain in droplet 1618, while droplet 1610 may be substantially free of magnetically responsive beads 1618. The process may, for example, be employed in a merge-and-split bead washing protocol.

**Figure 17** illustrates a process of facilitating consistent droplet splitting by use of a magnetic physical barrier in the droplet actuator. Figure 17 shows a side view of the portion of droplet actuator 1600 that is described in Figure 16. However, Figure 17 shows that the substantially nonmagnetic physical barrier 1620 of Figure 16 is replaced with a magnetic physical barrier 1710. Figure 17 also shows that magnet 1616 of Figure 16 is removed from proximity to bottom

substrate 1612. The magnetic physical barrier 1710 is used to (1) immobilize the magnetically responsive beads 1618 and (2) to reduce the gap at the point of splitting, thereby assisting the droplet splitting operation. Additionally, because of the existence of the rigid magnetic physical barrier 1710, consistent splitting may be obtained substantially at the same point.

The process may include, but is not limited to, the following steps. In Step 1, the magnetic physical barrier 1710 immobilizes the magnetically responsive beads 1618 in the aqueous slug 1622. The aqueous slug 1622 is intersected by the magnetic physical barrier 1710, which reduces the gap. In Step 2, a droplet splitting operation is executed (e.g., forming droplets 1624 and 1626), whereby the magnetically responsive beads remain substantially immobilized by the magnetic physical barrier 1710 and the magnetic physical barrier 1710 is used to reduce the gap at the point of splitting, thereby assisting the droplet splitting operation. In this example, magnetically responsive beads 1618 remain substantially immobilized in droplet 1624 by magnetic physical barrier 1710 and droplet 1626 is substantially free of beads 1618. The process may, for example, be employed in a merge-and-split bead washing protocol.

## 6.7 Electrode Configurations for Improved Droplet Splitting

**Figure 18** illustrates embodiments of electrode configuration for improved droplet splitting. In one example, Figure 18A shows an electrode path 1810 that includes a splitting region 1812 that includes a segmented electrode 1814, such as multiple electrode strips. In a splitting operation, electrodes may be activated to extend a slug across the region of electrode strips. The electrode strips may be deactivated starting with the outer strips and continuing to the inner strips in order to cause a controlled split of the droplet at the electrode strip region of the electrode path 1810. In an alternative embodiment, the electrode strips may be rotated 90 degrees. In this embodiment, deactivation may start from the inner electrodes of the electrode strips and continue to the outer electrodes in order to controllably split the droplet at the electrode strips.

In another example, Figure 18B shows an electrode path 1820 that includes a splitting region 1822 that includes a tapered electrode 1824 that may span a distance equivalent, for example, to about two standard droplet operations electrodes. In operation, a droplet may be extended along electrodes of the electrode path across tapered electrode 1824. Electrode 1824 or the adjacent electrode 1825 may be deactivated to controllably split the droplet.

In yet another example, Figure 18C shows an electrode pattern 1830 that includes a splitting region 1832 that includes a long tapered electrode 1834 and a short tapered electrode 1836, where the smallest end of the tapered electrodes face one another. The tapered electrode pair may span a distance equivalent, for example, to about three standard droplet operations electrodes. In operation, a droplet may be extended along electrodes of the electrode path across tapered electrodes 1834 and 1836. Electrode 1834 and/or electrode 1836 may be deactivated to controllably split the droplet.

In yet another example, Figure 18D shows an electrode pattern 1840 that includes a splitting region 1842 that includes a long tapered electrode 1842 and a short interlocking electrode 1844, where the smallest end of the tapered electrode 1842 faces the interlocking electrode 1844. The electrode pair may span a distance equivalent, for example, to about three standard droplet operations electrodes. In operation, a droplet may be extended along electrodes of the electrode path across tapered electrodes 1844 and 1846. Electrode 1844 and/or electrode 1846 may be deactivated to controllably split the droplet.

In yet another example, Figure 18E shows an electrode pattern 1850 that includes a splitting region 1852 that includes a segmented electrode 1854, such as multiple row or columns of electrode strips. In operation, a droplet may be extended along electrodes of the electrode path across splitting region 1852. Each segment may be independently deactivated as desired to controllably split the droplet.

## **6.8 Improved Detection**

A process for the detection of supernatant after adding a substrate to the assayed magnetically responsive beads is disclosed, in accordance with the invention. After the washing protocol to remove the excess unbound antibody is complete, a chemiluminescent substrate is added to the assayed and washed beads, which produces chemiluminescence as a result of the reaction between the enzyme on the beads and the substrate.

The substrate may be incubated with the magnetically responsive beads for some fixed time, where the magnetically responsive beads are substantially immobilized and the supernatant is transported away for detection. This approach reduces, preferably entirely eliminates, the need to transport the magnetically responsive bead droplet over long distances to the detector and also

reduces, preferably entirely eliminates, the possibility of loss of beads during the transport operation.

Alternatively the antibody-antigen-enzyme complex can be released from the bead by chemical or other means into the supernatant. The beads may then be substantially immobilized and the supernatant processed further for detection.

Additionally, the same split, merge, and transport strategies that are explained for incubating beads/antibodies/sample mixture may be employed here also for incubating substrate and assayed beads.

Bead based sandwich or competitive affinity assays, such as ELISAs, may be performed using the procedures described in this application in conjunction with various steps described in International Patent Application No. PCT/US 06/47486, entitled "Droplet-Based Biochemistry," filed on December 11, 2006. Further, after incubation, unbound sample material and excess reporter antibody or reporter ligand may be washed away from the bead-antibody-antigen complex using various droplet operations. A droplet of substrate (e.g., alkaline phosphatase substrate, APS-5) may be delivered to the bead-antibody-antigen complex. During incubation, the substrate is converted to product which begins to chemiluminesce. The decay of the product (which generates light) is sufficiently slow that the substrate-product droplet can be separated from the alkaline phosphatase-antibody complex and still retain a measurable signal. After an incubation period of the substrate with the bead-antibody-antigen complex (seconds to minutes), the magnetically responsive bead-antibody-antigen complex may be retained with a magnetic field (e.g., see U.S. Patent Application No. 60/900,653, filed on February 9, 2007, entitled "Immobilization of magnetically-responsive beads during droplet operations,") or by a physical barrier (e.g., see U.S. Patent Application No. 60/881,674, filed on January 22, 2007, entitled "Surface-assisted fluid loading and droplet dispensing," the entire disclosure of which is incorporated herein by reference) and only the substrate-product droplet may be presented (using droplet operations) to the sensor (e.g., PMT) for quantitation of the product.

The substrate-product droplet alone is sufficient to generate a signal proportional to the amount of antigen in the sample. Incubation of the substrate with the magnetically responsive bead-antibody-antigen complex produces enough product that can be quantitated when separated from the enzyme (e.g., alkaline phosphatase). By measuring the product in this manner, the bead-antibody-antigen complex does not have to be presented to the PMT. There are no beads or



proteins to “foul” the detector area as they are never moved to this area. Also the product droplet does not have to oscillate over the detector to keep beads in suspension during quantitation. The droplet volume may also be reduced in the absence of beads. Detection of the bead-antibody-antigen complex may employ a slug of liquid (e.g., 4 droplets) to move the complex, whereas with the beadless method the droplet could be smaller (e.g., less than 4 droplets). Time to result may also be shorter with this approach when performing multiplex ELISAs because the product droplet can be moved to the detector more quickly in the absence of beads.

Bead based sandwich or competitive affinity assays, such as ELISAs, may be performed using droplet operations for one or more steps, such as combining sample, capture beads and reporter antibody or reporter ligand. After incubation, unbound sample material and excess reporter antibody or reporter ligand may be washed away from the bead-antibody-antigen complex using an on-chip washing protocol. After washing, a droplet of substrate (e.g., alkaline phosphatase substrate, APS-5) may be delivered to the bead-antibody-antigen complex. During the incubation, the substrate is converted to product which begins to chemiluminesce. The decay of the product (which generates light) is sufficiently slow that the substrate-product droplet can be separated from the alkaline phosphatase-antibody complex and still retain a measurable signal. After an incubation period of the substrate with the bead-antibody-antigen complex (seconds to minutes), the magnetically responsive bead-antibody-antigen complex may be retained with a magnet or by a physical barrier and only the substrate-product droplet may be presented (using droplet operations) to the sensor (e.g., PMT) for quantitation of the product.

The substrate-product droplet alone is sufficient to generate a signal proportional to the amount of antigen in the sample. Incubation of the substrate with the magnetically responsive bead-antibody-antigen complex produces enough product that can be quantitated when separated from the enzyme (e.g., alkaline phosphatase). By measuring the product in this manner, the bead-antibody-antigen complex does not have to be presented to the PMT. There are no beads or proteins to “foul” the detector area as they are never moved to this area. Also the product droplet does not have to oscillate over the detector to keep beads in suspension during quantitation. The droplet volume may also be reduced in the absence of beads. Detection of the bead-antibody-antigen complex may employ a slug of liquid (e.g., 4 droplets) to move the complex, whereas with the beadless method the droplet could be smaller (e.g., less than 4 droplets). Time to result may also be shorter with this approach when performing multiplex ELISAs because the product droplet can be moved to the detector more quickly in the absence of beads.

**Figure 19** illustrates detection strategies for quantifying an analyte. In particular, the immunoassay may be developed without any secondary antibody that is labeled with enzyme, fluorophore, or quantum dots. After binding of the analyte to the antibody that is bound to the magnetically responsive beads, the hydrodynamic diameter of the beads increases due to the immune complex that is bound to the surface of the bead. A superconductive quantum interference device (SQUID) gradiometer system may be used in order to measure the standard magnetization (Ms) of magnetically labeled immune complexes, such as the A<sub>5</sub>-Ag complex shown in Figure 19.

## 6.9 Operation Fluids

For examples of fluids that may be subjected to droplet operations using the approach of the invention, see the patents listed in section 2, especially International Patent Application No. PCT/US2006/047486, entitled, "Droplet-Based Biochemistry," filed on December 11, 2006. In some embodiments, the fluid includes a biological sample, such as whole blood, lymphatic fluid, serum, plasma, sweat, tear, saliva, sputum, cerebrospinal fluid, amniotic fluid, seminal fluid, vaginal excretion, serous fluid, synovial fluid, pericardial fluid, peritoneal fluid, pleural fluid, transudates, exudates, cystic fluid, bile, urine, gastric fluid, intestinal fluid, fecal samples, fluidized tissues, fluidized organisms, biological swabs, biological washes, liquids with cells, tissues, multicellular organisms, single cellular organisms, protozoa, bacteria, fungal cells, viral particles, organelles. In some embodiment, the fluid includes a reagent, such as water, deionized water, saline solutions, acidic solutions, basic solutions, detergent solutions and/or buffers. In some embodiments, the fluid includes a reagent, such as a reagent for a biochemical protocol, such as a nucleic acid amplification protocol, an affinity-based assay protocol, a sequencing protocol, and/or a protocol for analyses of biological fluids.

The fluids may include one or more magnetically responsive and/or non-magnetically responsive beads. Examples of droplet actuator techniques for immobilizing magnetically responsive beads and/or non-magnetically responsive beads are described in the foregoing international patent applications and in Sista, et al., U.S. Patent Application No. 60/900,653, entitled "Immobilization of Magnetically-responsive Beads During Droplet Operations," filed on February 9, 2007; Sista et al., U.S. Patent Application No. 60/969,736, entitled "Droplet Actuator Assay Improvements," filed on September 4, 2007; and Allen et al., U.S. Patent Application No. 60/957,717, entitled "Bead Washing Using Physical Barriers," filed on August 24, 2007, the entire disclosures of which is incorporated herein by reference.

## **7 Concluding Remarks**

The foregoing detailed description of embodiments refers to the accompanying drawings, which illustrate specific embodiments of the invention. Other embodiments having different structures and operations do not depart from the scope of the present invention. This specification is divided into sections for the convenience of the reader only. Headings should not be construed as limiting of the scope of the invention. The definitions are intended as a part of the description of the invention. It will be understood that various details of the present invention may be changed without departing from the scope of the present invention. Furthermore, the foregoing description is for the purpose of illustration only, and not for the purpose of limitation, as the present invention is defined by the claims as set forth hereinafter.

## The Claims

We claim:

1. A method of circulating magnetically responsive beads within a droplet in a droplet actuator, the method comprising:
  - (a) providing a droplet actuator, comprising:
    - (i) a plurality of droplet operations electrodes configured to transport the droplet; and
    - (ii) a magnet field present at a portion of the plurality of droplet operations electrodes;
  - (b) providing a bead-containing droplet on the droplet actuator in the presence of the uniform magnetic field; and
  - (c) circulating beads in the droplet during incubation by conducting droplet operations on the droplet within a uniform region of the magnetic field.
2. The method of any of the foregoing claims wherein the beads comprise molecules having affinity for one or more target substances in the droplet.
3. The method of any of the foregoing claims wherein the beads comprise cells.
4. The method of any of the foregoing claims wherein the beads comprise organisms.
5. The method of any of the foregoing claims wherein the droplet is surrounded by a filler fluid.
6. The method of any of the foregoing claims wherein the method is executed in a manner which avoids clumping of magnetic beads.
7. The method of any of the foregoing claims wherein the droplet operations comprise transporting the droplet within the uniform region of the magnetic field.

8. The method of claim 7 wherein the droplet operations comprise transporting the droplet back and forth or in a loop within the uniform region of the magnetic field.
9. The method of claim 7 wherein the droplet operations comprise transporting the droplet back and forth or in a loop within the uniform region of the magnetic field across droplet operations electrodes that vary in size.
10. The method of claim 7 wherein the droplet operations comprise oscillating the droplet within the uniform region of the magnetic field.
11. The method of any of the foregoing claims wherein the droplet operations comprise splitting the droplet within the uniform region of the magnetic field.
12. The method of any of the foregoing claims wherein the droplet operations comprise splitting and merging the droplet within the uniform region of the magnetic field.
13. The method of any of the foregoing claims wherein the droplet operations comprise splitting and merging and transporting the droplet within the uniform region of the magnetic field.
14. The method of any of the foregoing claims wherein the droplet is sandwiched between two substrates.
15. The method of any of the foregoing claims further comprising splitting the droplet.
16. The method of any of the foregoing claims wherein the droplet is maintained at a temperature suitable for incubation of the contents of the droplet.
17. The method of any of the foregoing claims further comprising transporting the droplet away from the magnetic field.
18. The method of any of the foregoing claims further comprising splitting the droplet away from the magnetic field.

19. The method of any of the foregoing claims further comprising splitting the droplet while proximate an edge of a magnet emanating the magnetic field.
20. The method of any of the foregoing claims further comprising recombining the resultant split droplets in the presence of the magnetic field.
21. The method of any of the foregoing claims further comprising a split droplet along the plurality of droplet operations electrodes away from the magnetic field.
22. The method of any of the foregoing claims further comprising transporting split droplets along the plurality of droplet operations electrodes in opposite directions.
23. The method of any of the foregoing claims further comprising producing the magnetic field using at least one magnet of a row of magnets.
24. The method of any of the foregoing claims further comprising producing the magnetic field using at least one magnet of a plurality of rows of magnets.
25. A method of manipulating a droplet comprising magnetically responsive beads within a droplet actuator, the method comprising:
  - (a) providing a droplet actuator, comprising:
    - (i) a plurality of droplet operations electrodes configured to transport the droplet; and
    - (ii) a magnetic field present at a portion of the plurality of droplet operations electrodes; and
  - (b) positioning a magnetic shielding material in the droplet actuator to selectively minimize the magnetic field.
26. A method of re-suspending bead within a droplet in a droplet actuator, the method comprising:

- (a) providing a droplet actuator, comprising:
    - (i) a plurality of reservoir electrodes configured to manipulate a droplet; and
    - (ii) a plurality of droplet operations electrodes in fluid communication with the plurality of reservoir electrodes; and
  - (b) operating the plurality of reservoir electrodes to cause the particulate to re-suspend within the droplet.
27. The method of claim 26 wherein independently operating the plurality of reservoir electrodes further comprises randomly activating and deactivating the reservoir electrodes.
28. The method of claim 26 wherein independently operating the plurality of reservoir electrodes further comprises alternatively and/or concurrently activating and deactivating the reservoir electrodes.
29. A method of re-suspending bead within a droplet in a droplet actuator, the method comprising:
- (a) providing a droplet actuator, comprising:
    - (i) a reservoir electrode configured to manipulate a droplet; and
    - (ii) a plurality of droplet operations electrodes in fluid communication with the reservoir electrode;
  - (b) separating a slug of the droplet from the droplet on the reservoir electrode; and
  - (c) recombining the slug with the droplet at the reservoir electrode.
30. The method of claim 29 further comprising transporting the slug along the plurality of droplet operations electrodes.

31. The method of claim 29 further comprising repeating steps (b) and (c).
32. A method of re-suspending particulate within a droplet in a droplet actuator, the method comprising:
- (a) providing a droplet actuator, comprising:
  - (b) a reservoir electrode configured to manipulate a droplet; and
  - (c) a plurality of droplet operations electrodes in fluid communication with the reservoir electrode; and
  - (d) selectively applying across the reservoir electrode a voltage from an alternating current source to agitate the droplet.
33. The method of claim 32 wherein the particulate comprises a bead.
34. The method of claim 32 wherein the particulate comprises a biological cell.
35. The method of claim 32 wherein the particulate comprises a biological organism.
36. A method of manipulating a droplet comprising magnetically responsive beads within a droplet actuator, the method comprising:
- (a) providing a droplet actuator comprising:
    - (i) a plurality of droplet operations electrodes configured to transport the droplet; and
    - (ii) a magnetic field present at a portion of the plurality of droplet operations electrodes; and
  - (b) positioning a plurality of magnets so as to selectively minimize the magnetic field.



37. The method of claim 36 wherein the magnetic field is sufficiently strong to hold the magnetically responsive beads substantially immobile during a droplet operation.
38. The method of claim 36 wherein the magnetic field is sufficiently weak to enable the magnetically responsive bead to be moved away from the magnetic field during a droplet operation.
39. A method of circulating magnetically responsive beads within a droplet on a droplet actuator, the method comprising:
- (a) providing a droplet actuator, comprising:
    - (i) top and bottom substrates;
    - (ii) a plurality of magnetic fields respectively present proximate the top and bottom substrates, wherein at least one of the magnet fields is selectively alterable; and
    - (iii) a plurality of droplet operations electrodes positioned along at least one of the top and bottom surfaces;
  - (b) positioning the droplet between the top and bottom surfaces; and
  - (c) selectively altering at least one of the magnetic fields.
40. The method of claim 39 wherein altering at least one of the magnetic fields further comprises activating an electromagnet proximate at least one of the top and bottom surfaces.
41. The method of claim 39 wherein altering at least one of the magnetic fields further comprises activating and deactivating the magnetic fields in a pattern which causes the beads to circulate within the droplet.

42. The method of claim 39 wherein altering at least one of the magnetic fields further comprises activating an electromagnet proximate only one of the top and bottom surfaces.
43. The method of claim 39 further comprising selectively activating at least one of a plurality of electromagnets positioned proximate the top surface.
44. The method of claim 39 further comprising selectively deactivating at least one of a plurality of electromagnets positioned proximate the top surface.
45. The method of claim 39 further comprising selectively activating at least one of a plurality of electromagnets positioned proximate the bottom surface.
46. The method of claim 39 further comprising selectively deactivating at least one of a plurality of electromagnets positioned proximate the bottom surface.
47. The method of claim 39 wherein altering at least one of the magnetic fields further comprises physically altering a position of a magnet emanating the at least one magnetic field.
48. A method of dispensing a bead-containing sub-droplet, the method comprising:
- (a) circulating the beads within the droplet as provided in claim claim 39; and
  - (b) using droplet operations to dispense the sub-droplet from the droplet.
49. A method of splitting a droplet comprising a magnetically responsive bead in a droplet actuator, the method comprising:
- (a) providing a droplet actuator comprising:
    - (i) a plurality of droplet operations electrodes configured to transport the droplet; and
    - (ii) a magnetic field present at the plurality of droplet operations electrodes;

- (b) immobilizing the magnetically responsive bead using the magnetic field; and
  - (c) using the plurality of droplet operations electrodes to split the droplet into first and second droplets, wherein the magnetically responsive bead remains substantially immobilized.
50. The method of claim 49 further wherein the splitting is facilitated using a hydrophilic patch.
51. The method of claim 49 further comprising using a magnet to generate the magnetic field.
52. The method of claim 49 further comprising using a magnet embedded within a gasket of the droplet actuator to generate the magnetic field.
53. The method of claim 49 further comprising positioning a magnet proximate a gasket of the droplet actuator to generate the magnetic field.
54. The method of claim 49 further comprising using a physical barrier to facilitate splitting of the droplet.
55. The method of claim 49 further comprising using a magnetized physical barrier to facilitate splitting of the droplet.
56. A method of splitting a droplet into two or more sub-droplets, the method comprising:
- (a) providing a droplet actuator comprising:
    - (i) a droplet operations surface comprising droplet operations electrodes, the droplet operations electrodes including one or more intermediate electrodes;
    - (ii) a top substrate separated from the droplet operations surface to form a gap;

- (iii) a physical barrier extending into the gap and constricting the gap in proximity with the one or more intermediate electrodes; and
  - (iv) a droplet on one or more of the droplet operations electrodes;
- (b) activating three or more of the droplet operations including one or more of the intermediate electrodes to elongate the droplet;
  - (c) deactivating one or more of the intermediate electrodes to cause the droplet to split into two sub-droplets.
57. The method of claim 56 wherein the barrier is mounted on, and extends into the gap from, the top substrate.
58. The method of claim 56 wherein the barrier produces a magnetic field.
59. The method of claim 56 wherein:
- (a) the droplet comprises beads or particles;
  - (b) the barrier restricts passage of the beads or particles; and
  - (c) the method yields:
    - (i) a first sub-droplet comprising substantially all of the beads or particles; and
    - (ii) a second droplet substantially lacking in beads or particles.

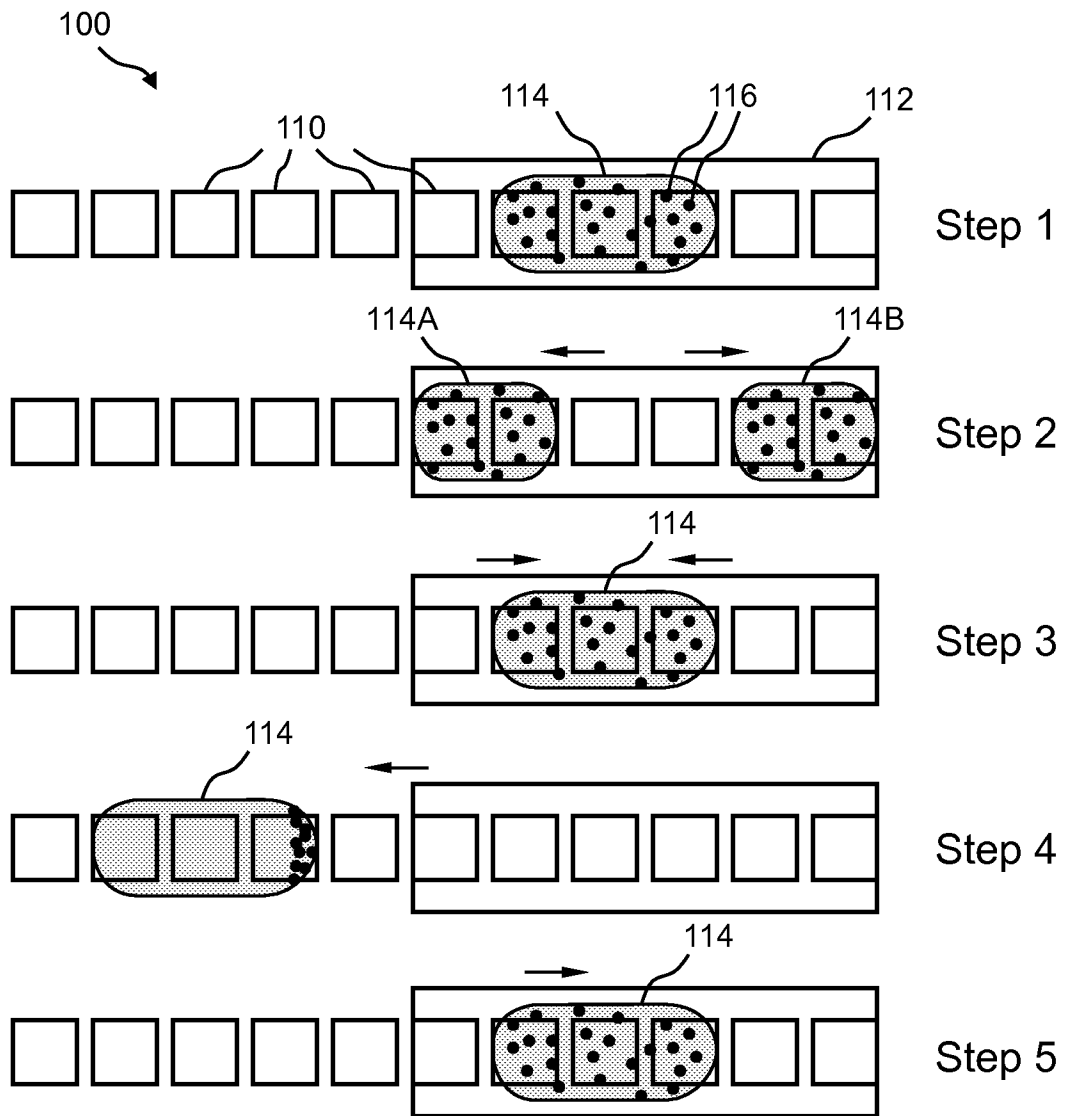

Figure 1

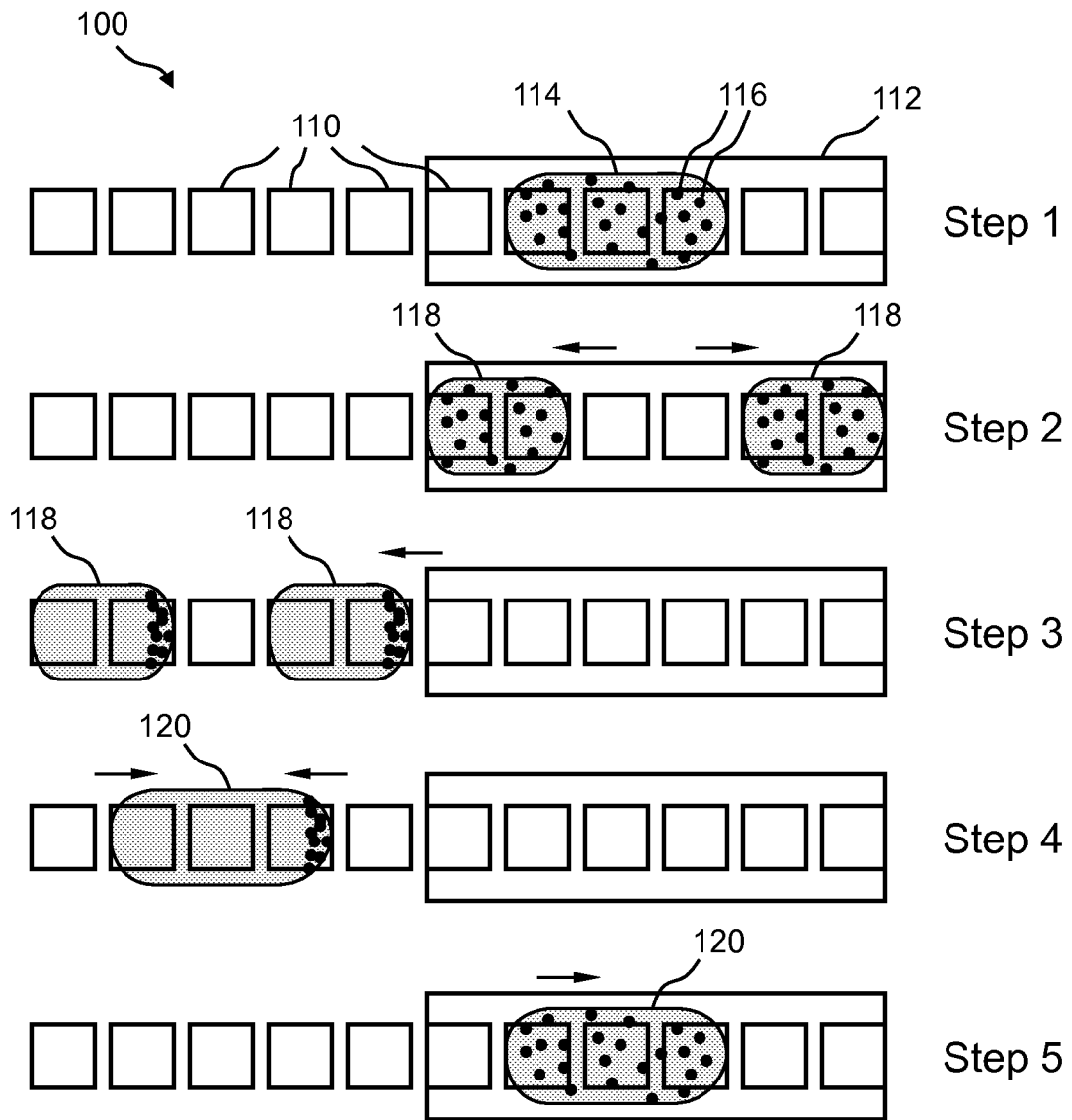

Figure 2

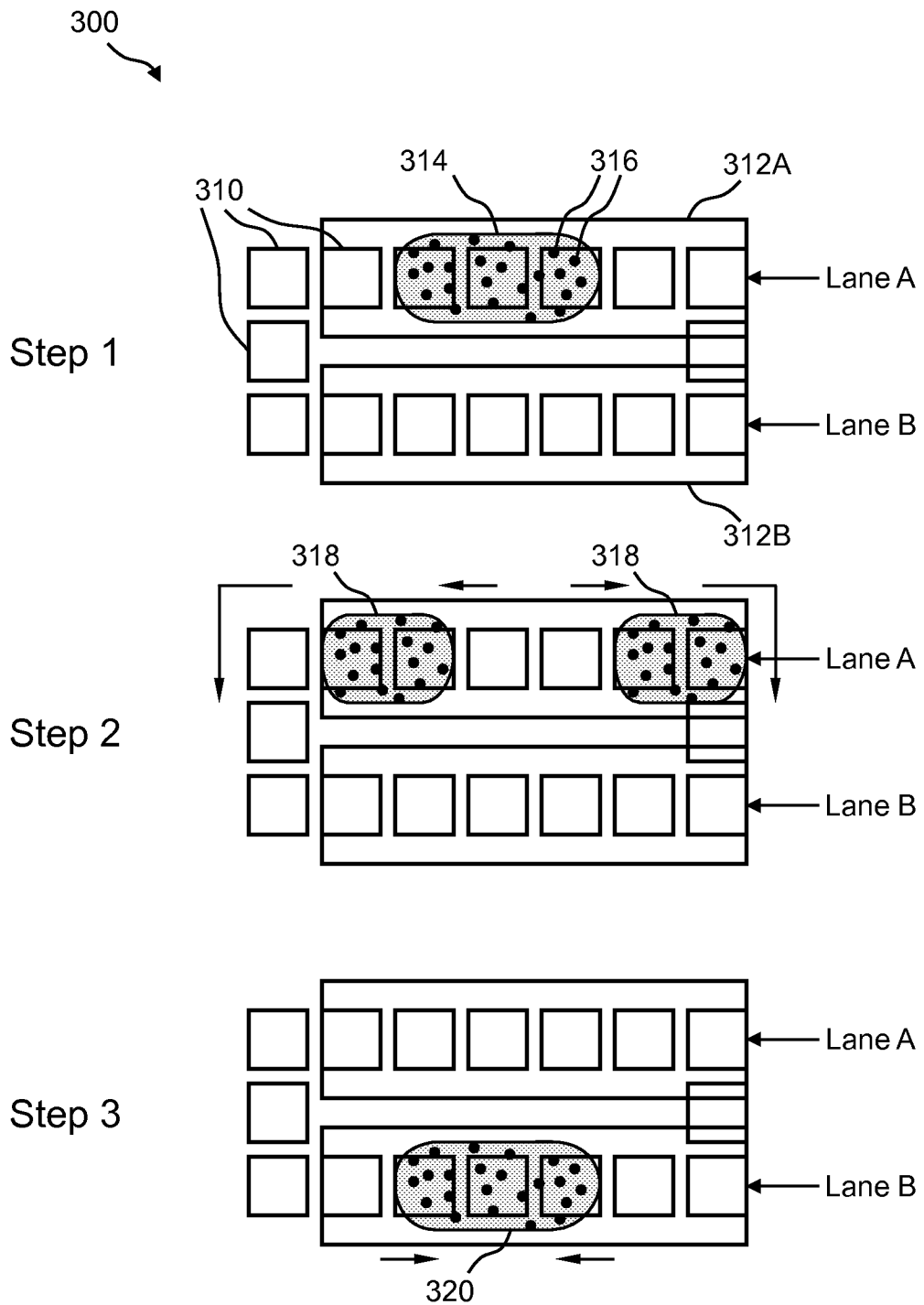

Figure 3

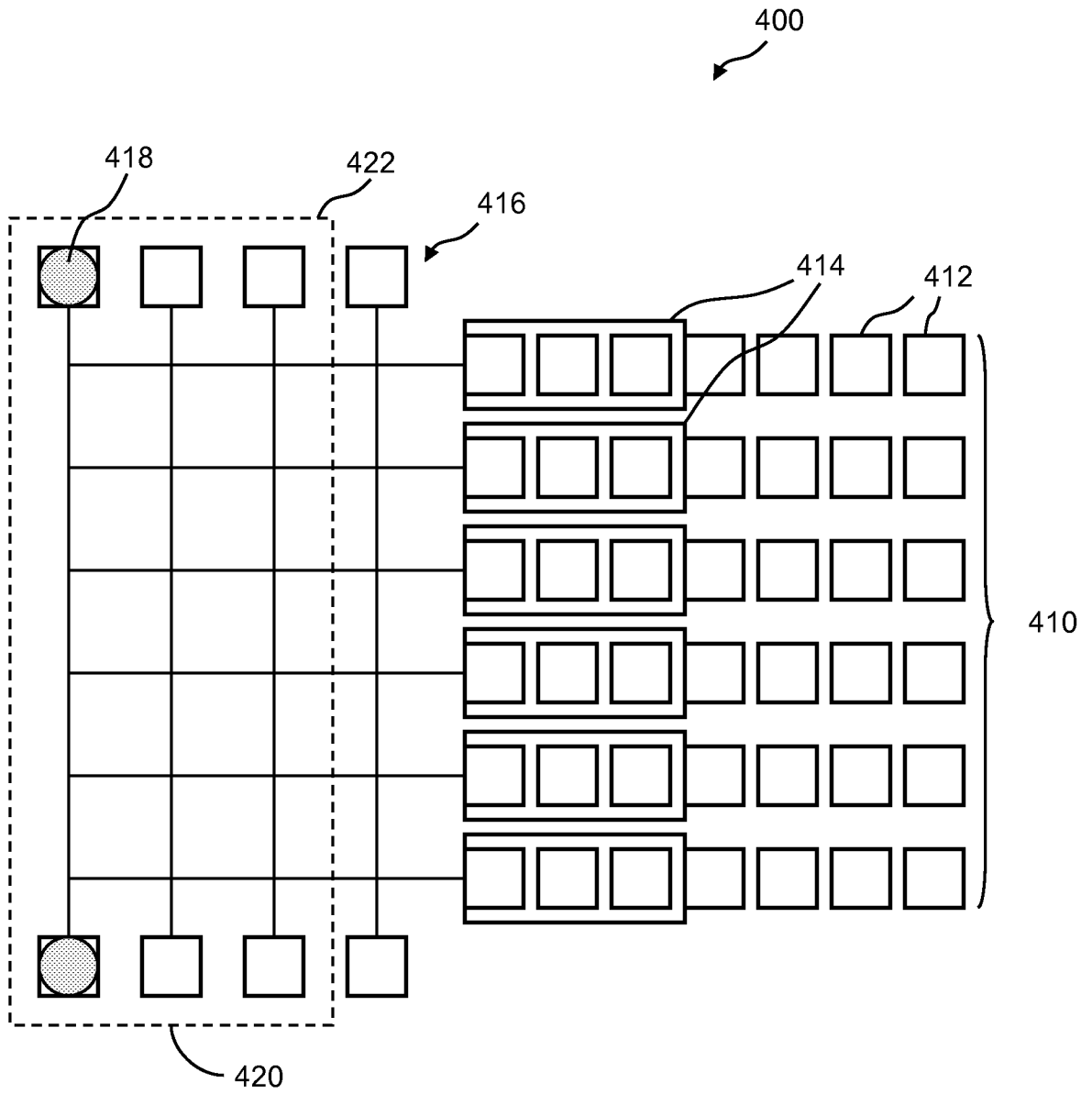
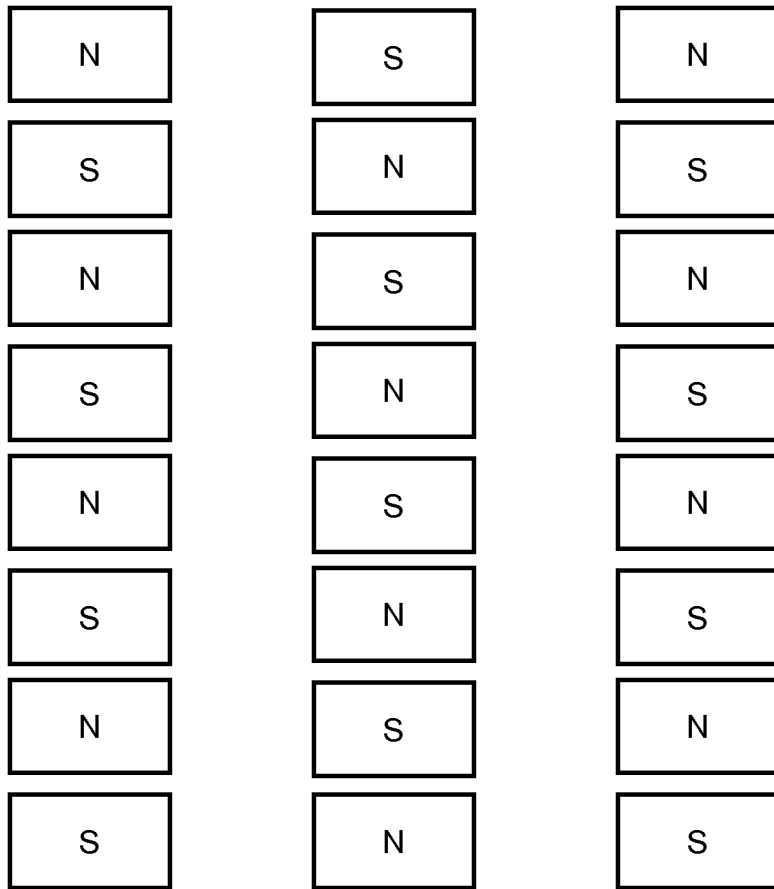

Figure 4



500  
↘



**Figure 5**

600

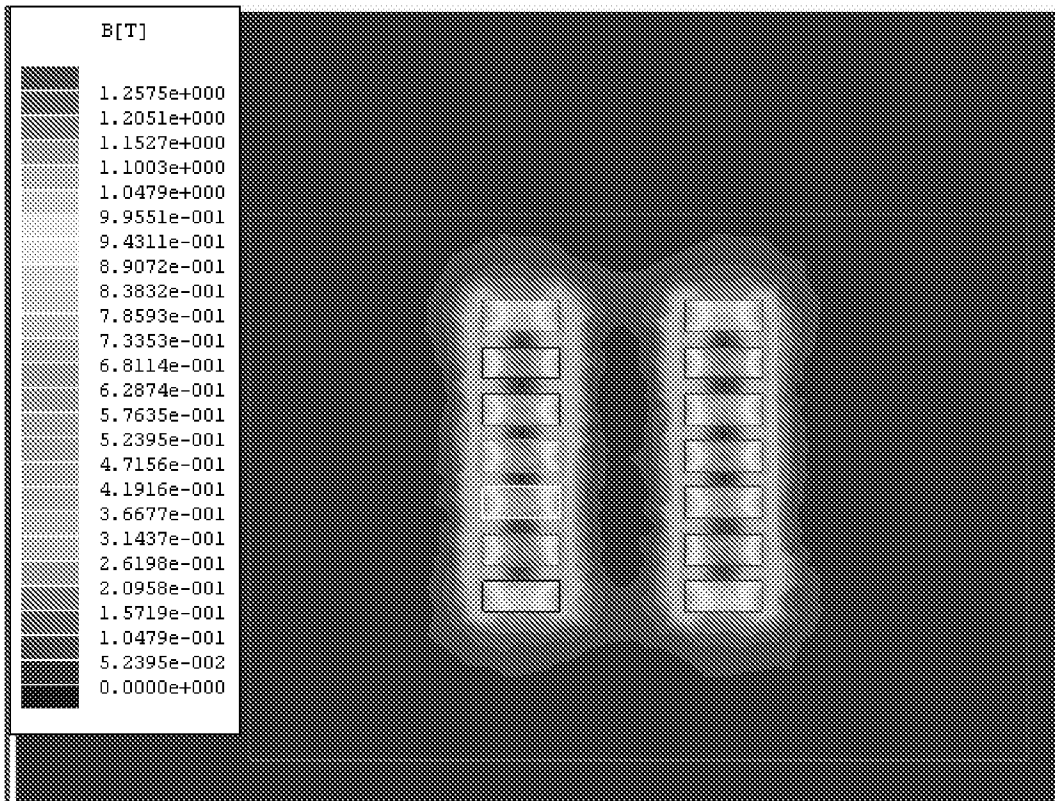

Figure 6

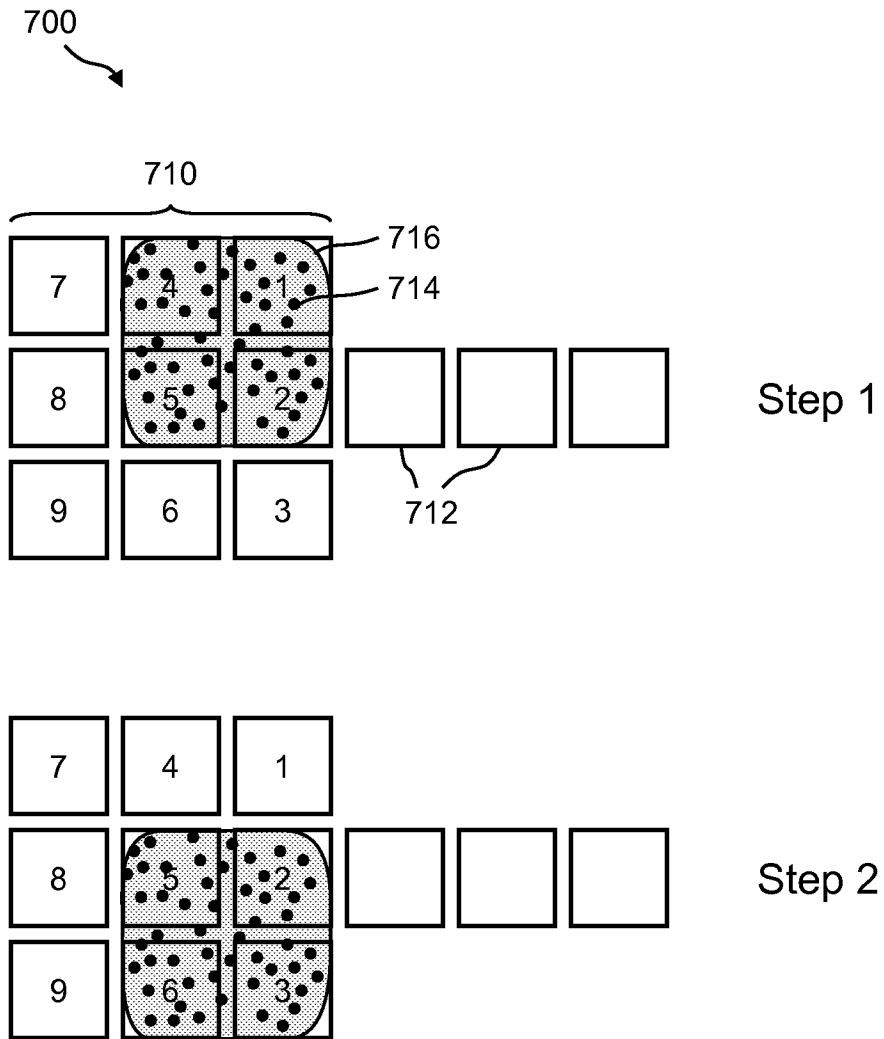

Figure 7

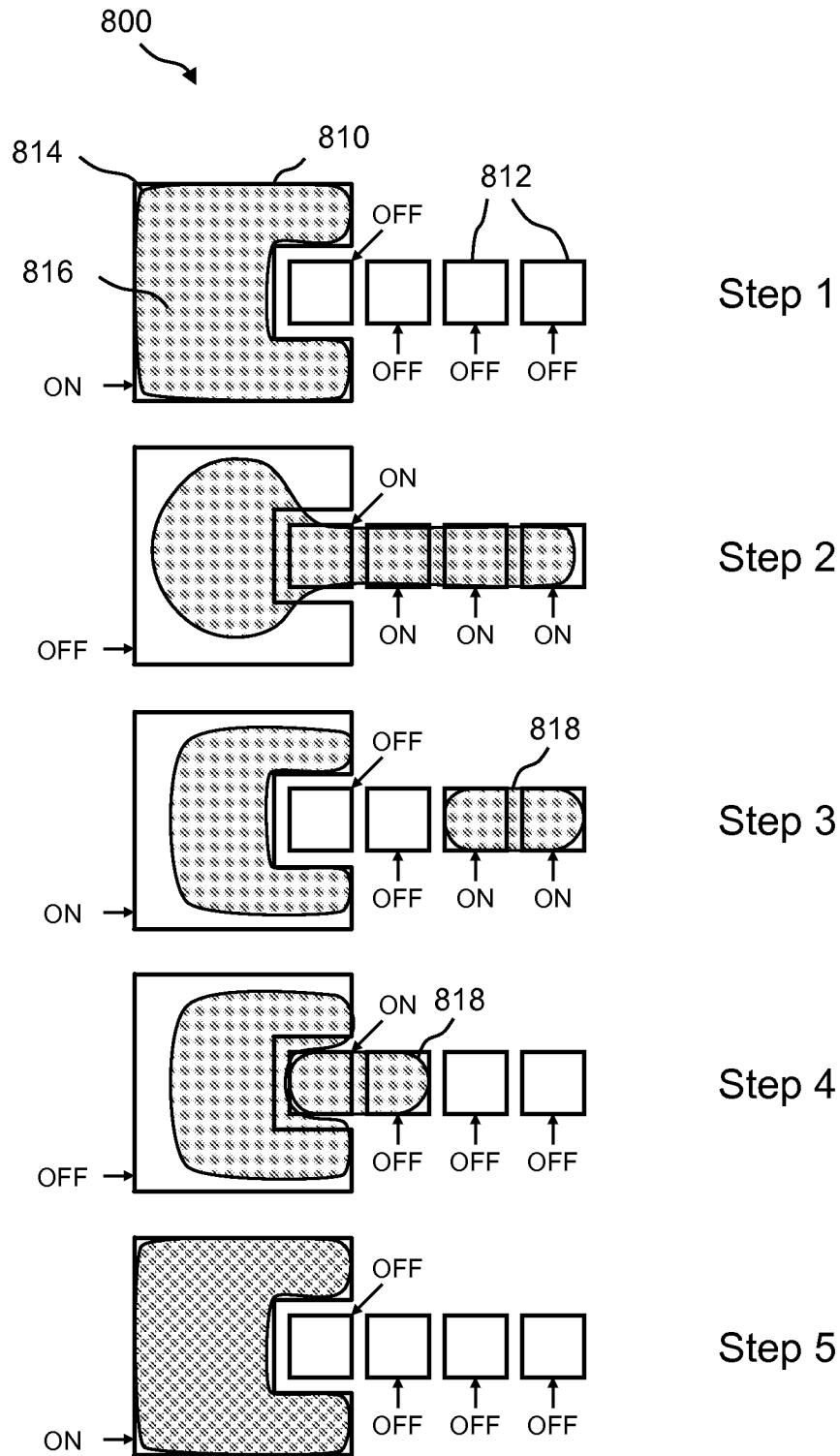
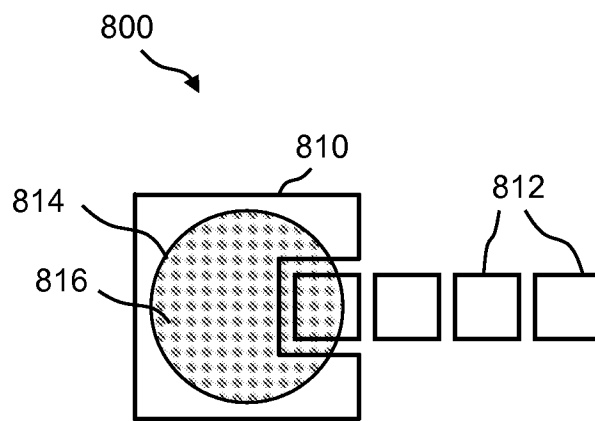

Figure 8



**Figure 9**

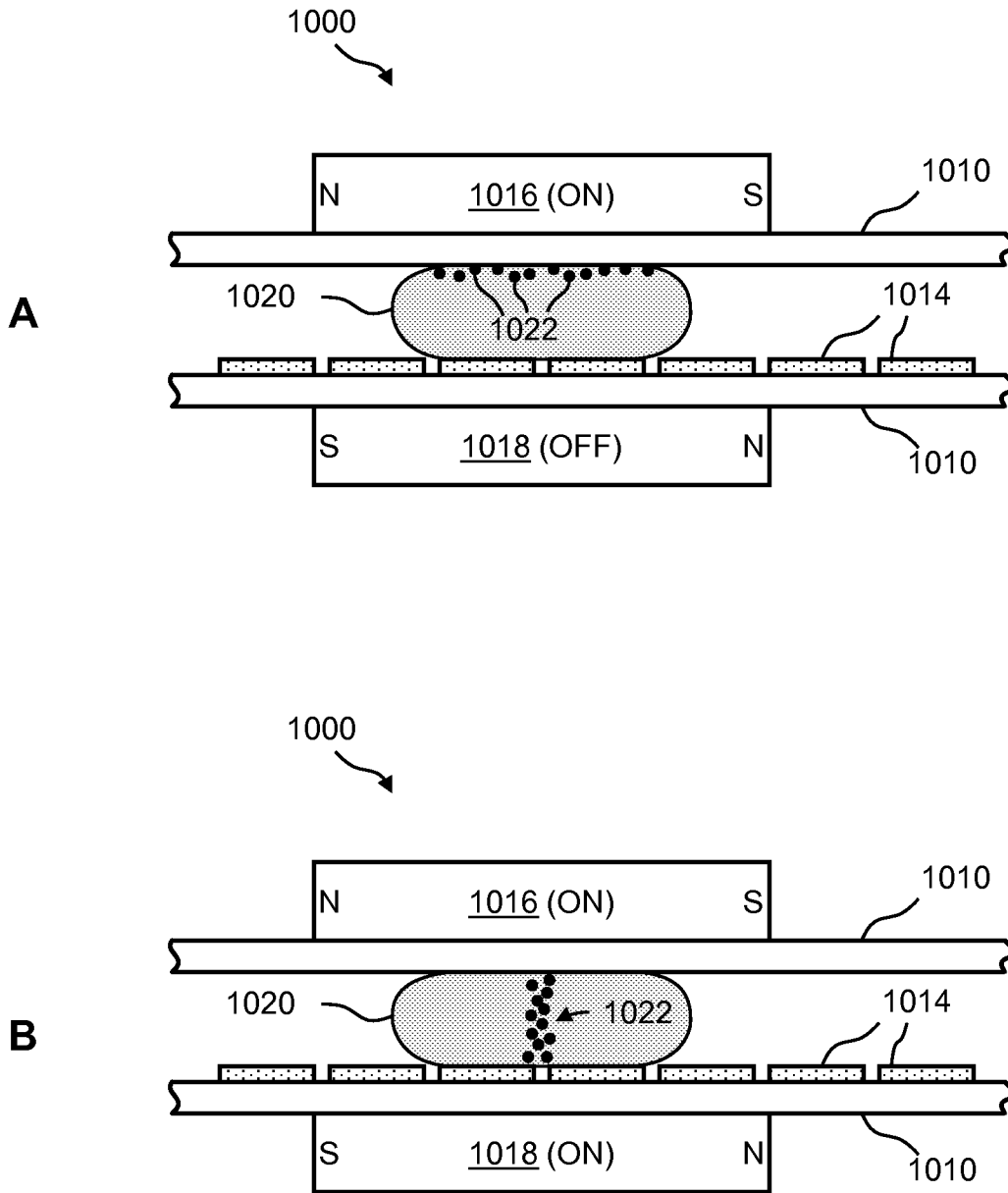

Figure 10

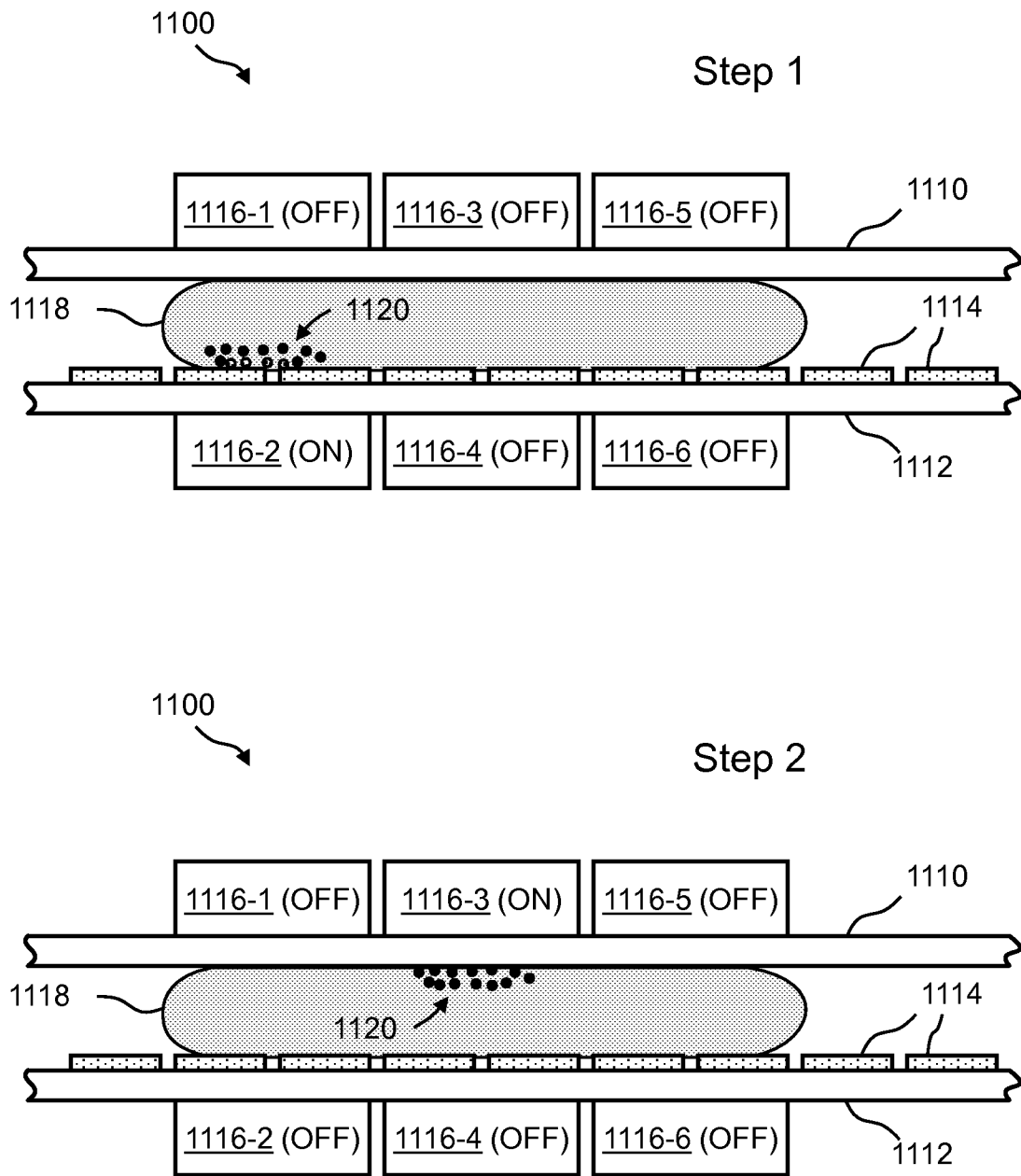

Figure 11

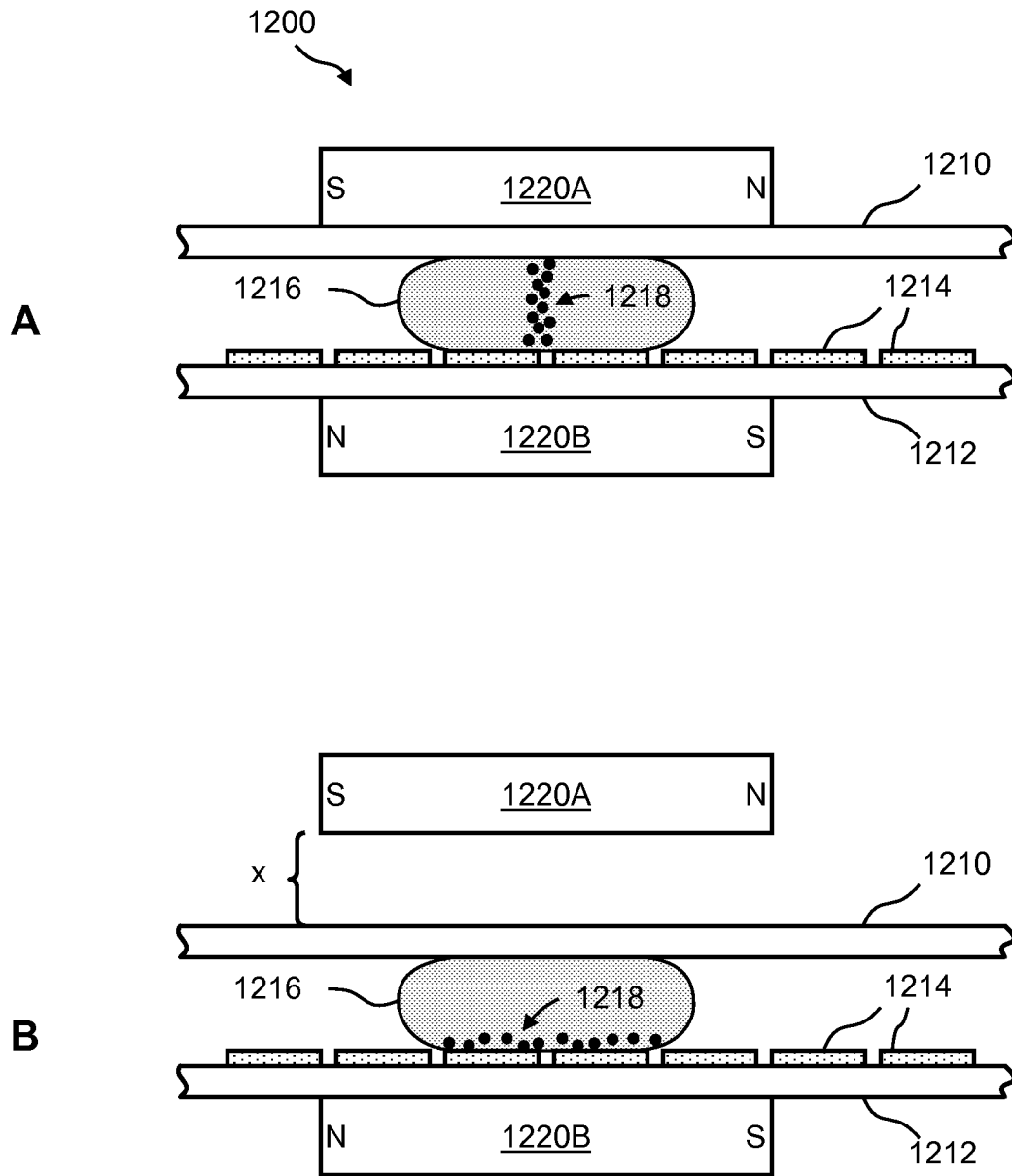

Figure 12



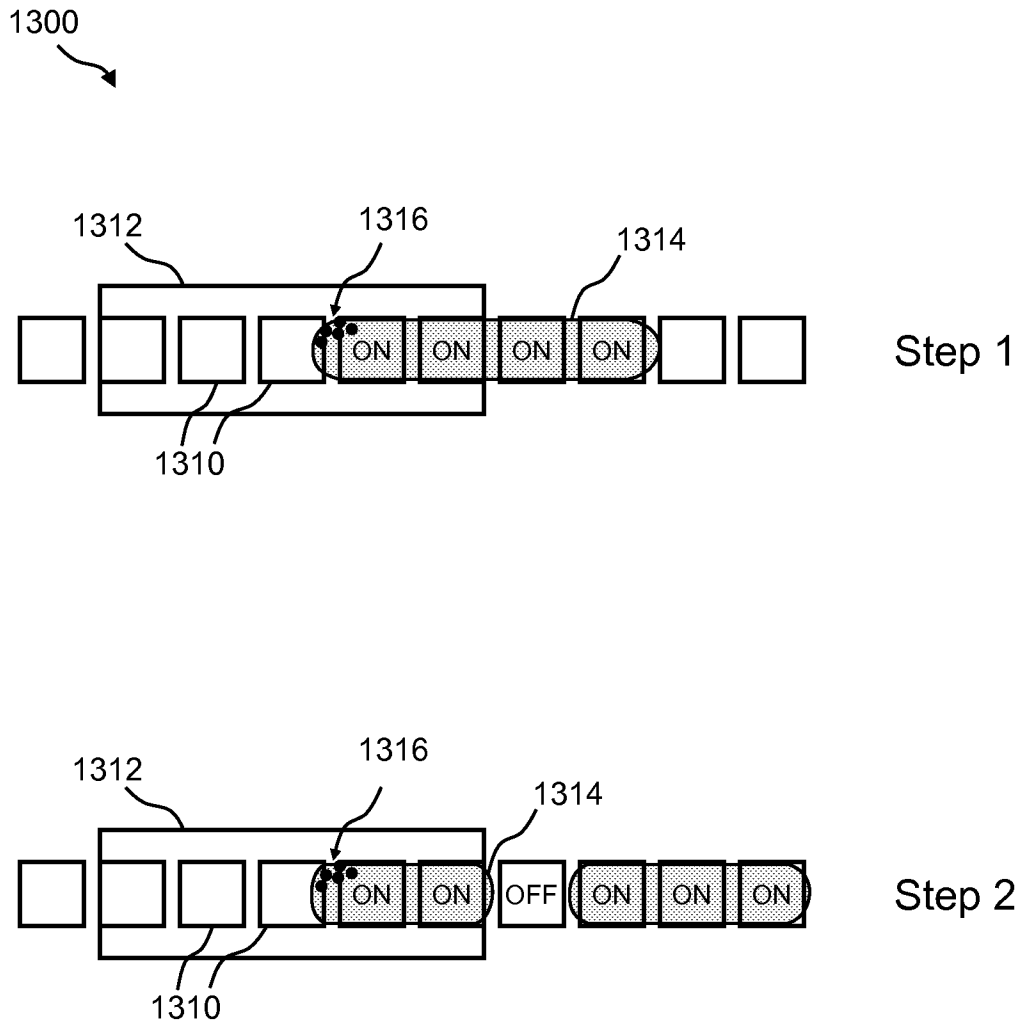

Figure 13

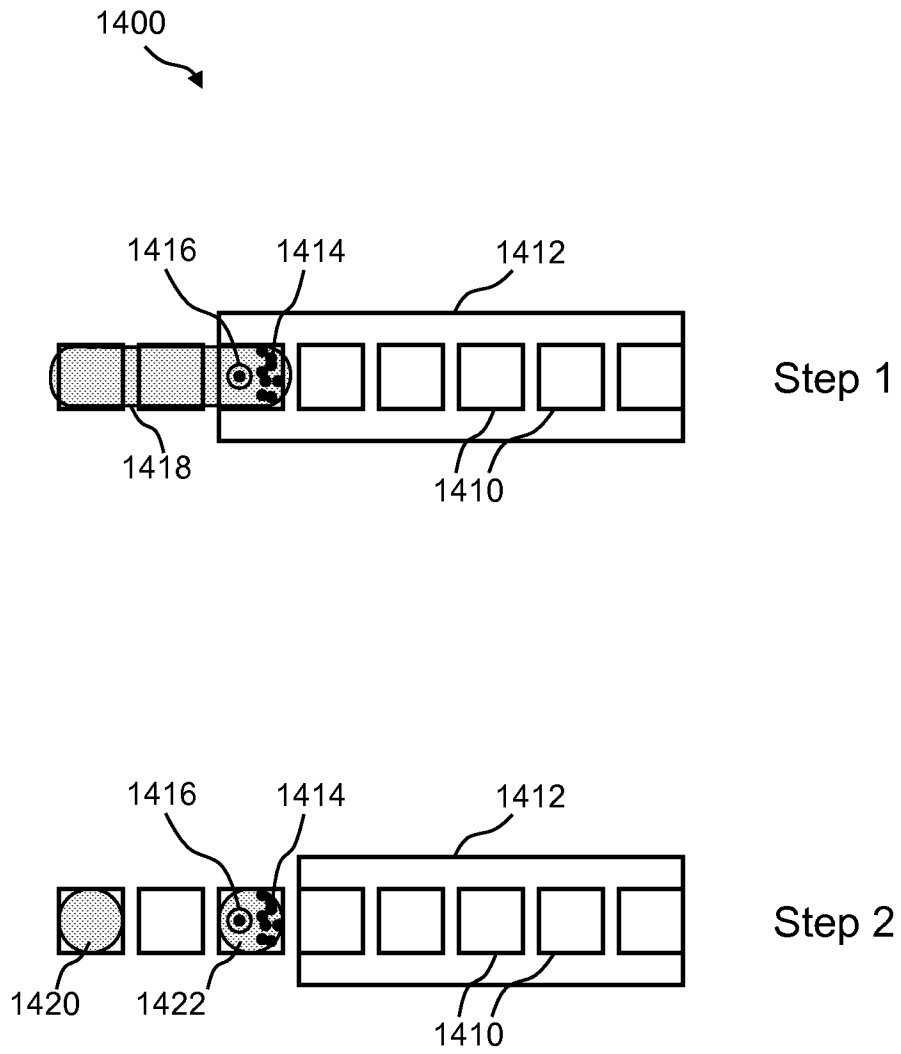

Figure 14

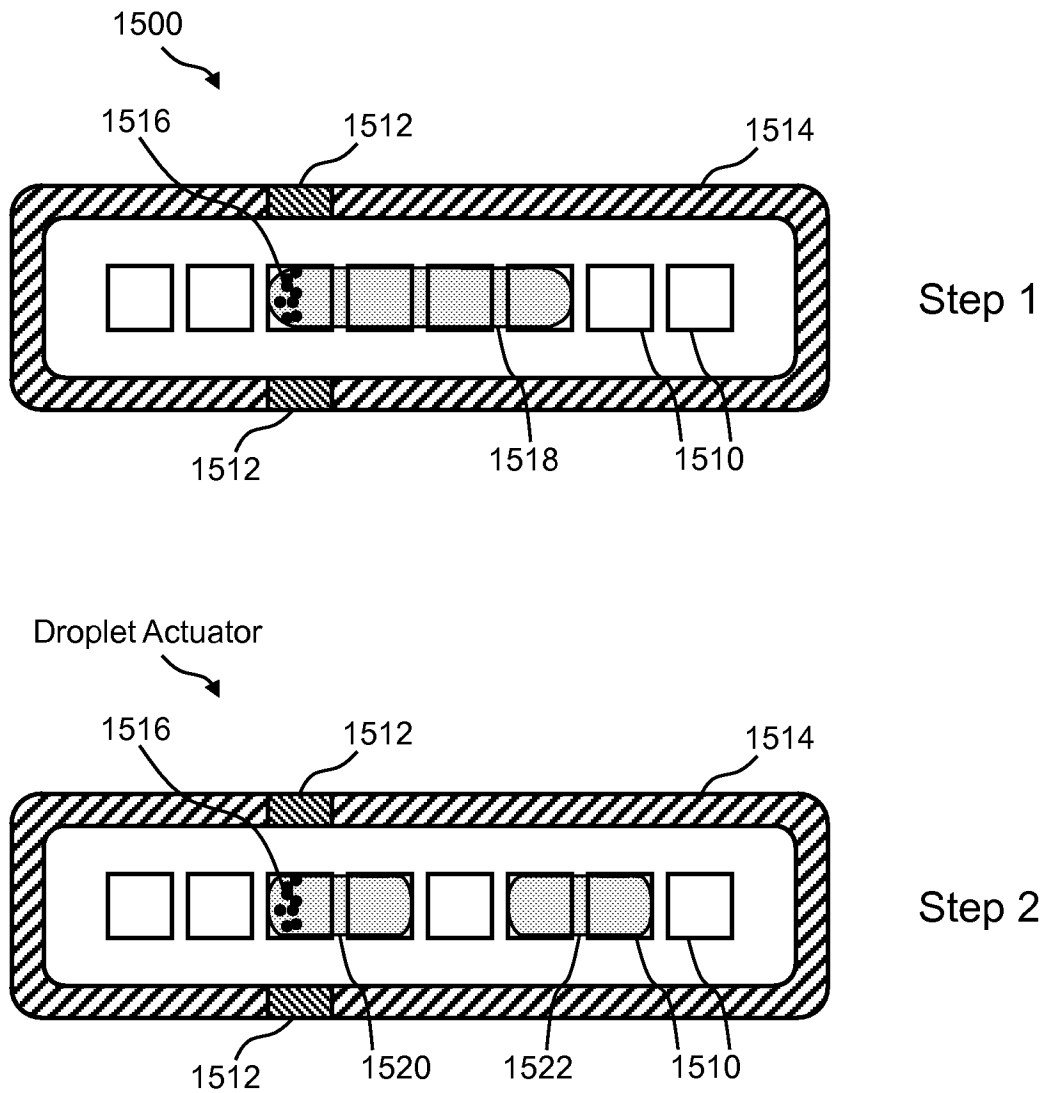

Figure 15

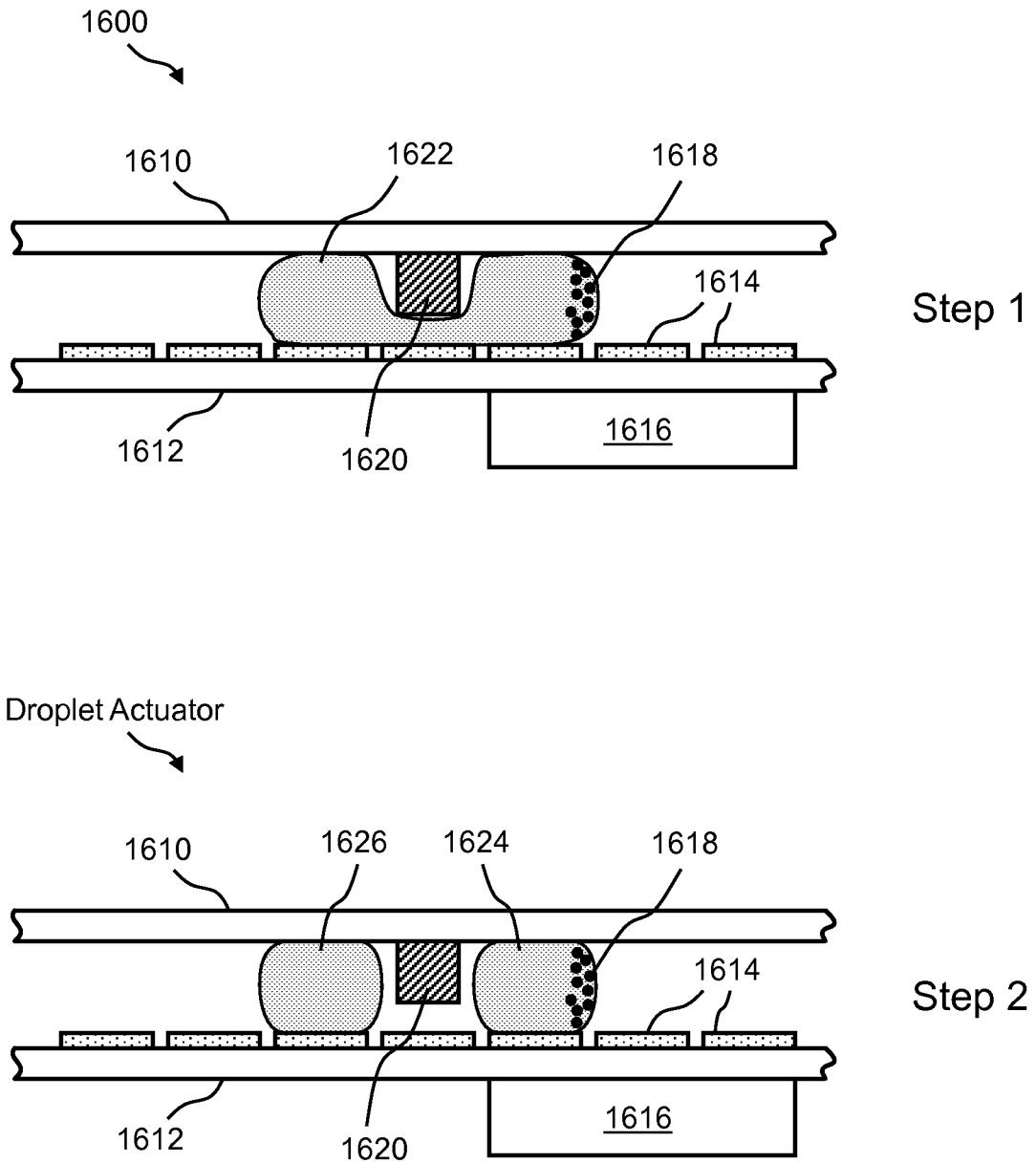

Figure 16

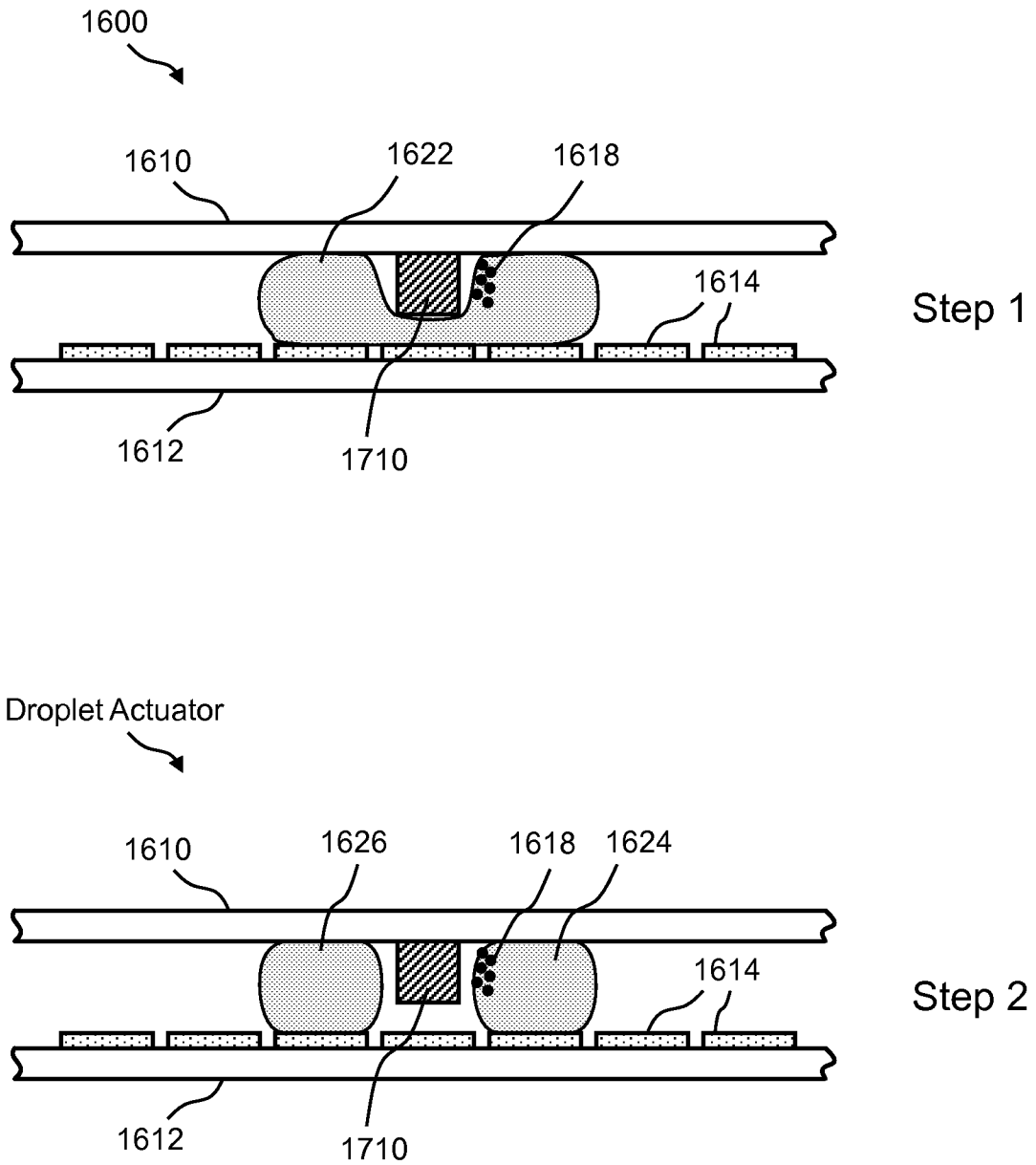

Figure 17

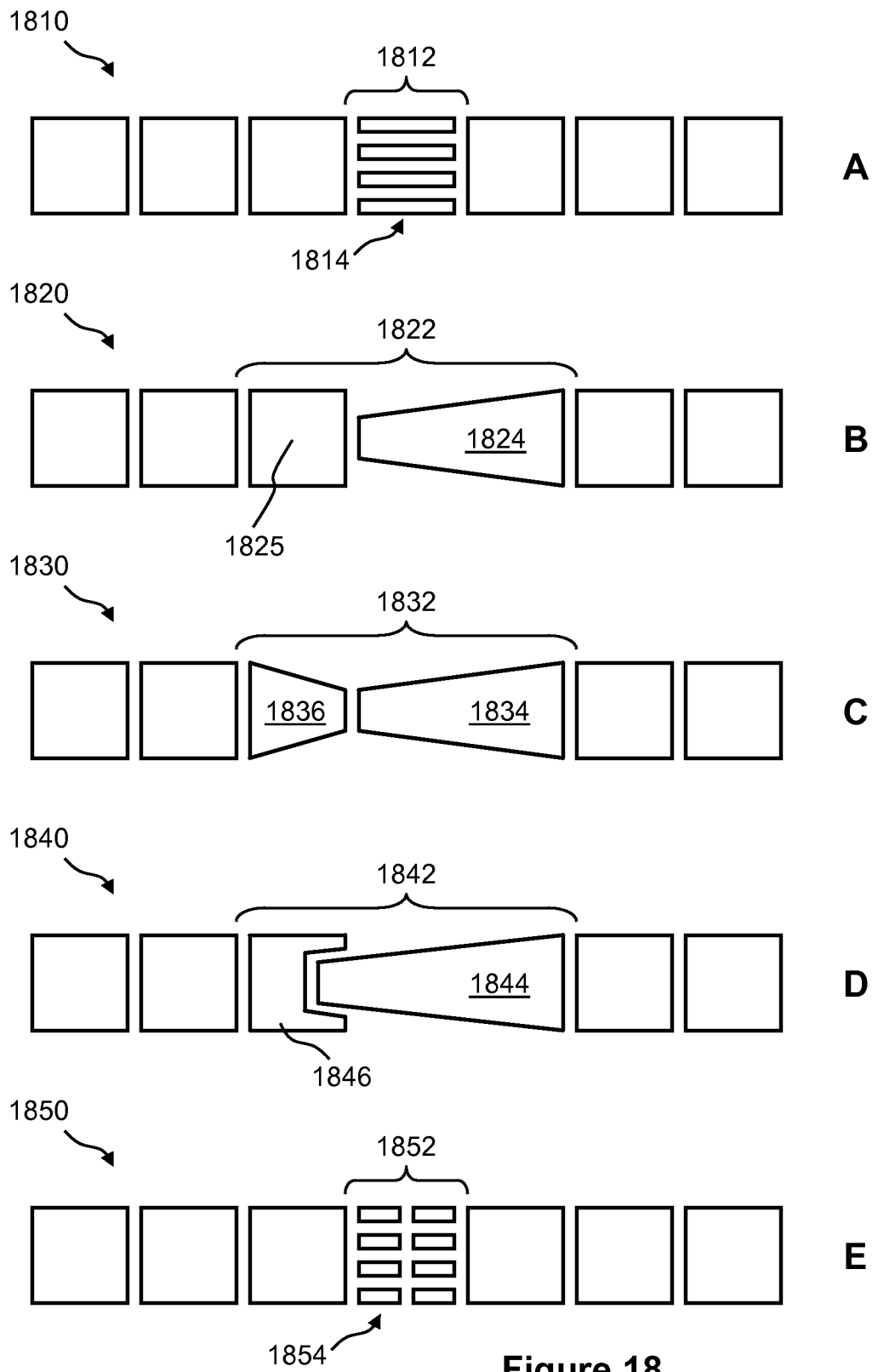

Figure 18

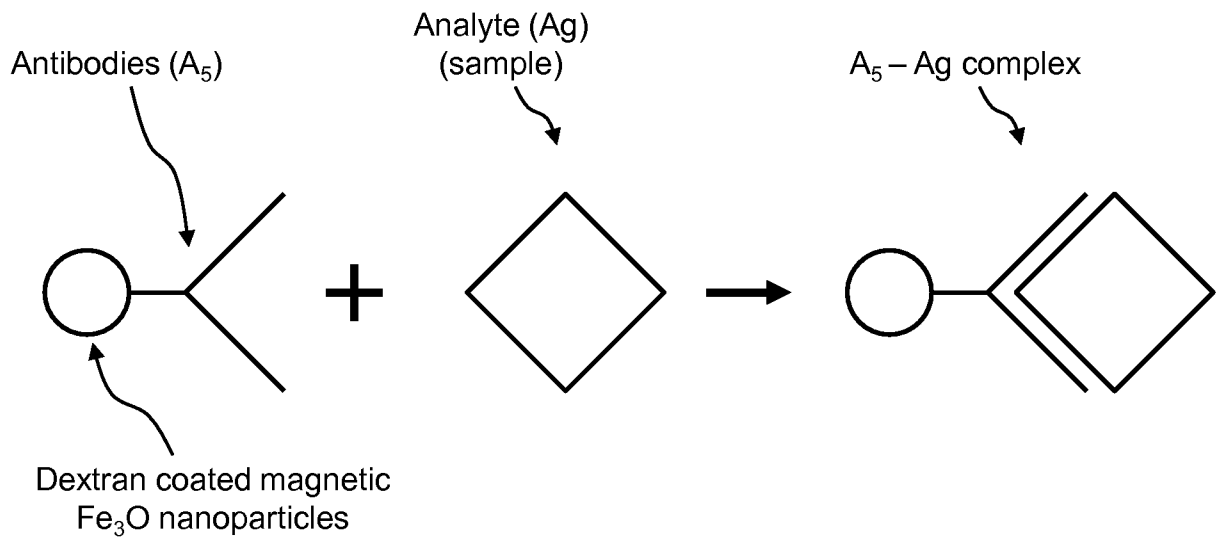

Figure 19