



## INTERNATIONAL APPLICATION PUBLISHED UNDER THE PATENT COOPERATION TREATY (PCT)

<p>(51) International Patent Classification <sup>5</sup> :  A61M 15/00</p>	<p>A1</p>	<p>(11) International Publication Number: <b>WO 94/05360</b>  (43) International Publication Date: 17 March 1994 (17.03.94)</p>
<p>(21) International Application Number: PCT/GB93/01894 (22) International Filing Date: 7 September 1993 (07.09.93)  (30) Priority data: 9218937.2 8 September 1992 (08.09.92) GB 9225389.7 4 December 1992 (04.12.92) GB  (71) Applicant (for all designated States except US): NORTON HEALTHCARE LIMITED [GB/GB]; Gemini House, Flex Meadow, Harlow, Essex CM19 5TS (GB).  (72) Inventors; and (75) Inventors/Applicants (for US only) : ANGEL, Clive, Graham [GB/GB]; 9 Hale Close, Melbourn, Royston, Hertfordshire SG8 6ET (GB). HARRIS, Mark, Alexander [GB/GB]; 5 Moat Lane, Melbourn, Royston, Hertfordshire SG8 6EH (GB). TRENEMAN, William, Richard [GB/GB]; 1 Coles Lane, Oakington, Cambridge, Cambs CB4 5BA (GB).</p>		<p>(74) Agent: BEN-NATHAN, Laurence, Albert; Urquhart-Dykes &amp; Lord, 91 Wimpole Street, London W1M 8AH (GB).  (81) Designated States: AT, AU, BB, BG, BR, BY, CA, CH, CZ, DE, DK, ES, FI, GB, HU, JP, KP, KR, KZ, LK, LU, LV, MG, MN, MW, NL, NO, NZ, PL, PT, RO, RU, SD, SE, SK, UA, US, UZ, VN, European patent (AT, BE, CH, DE, DK, ES, FR, GB, GR, IE, IT, LU, MC, NL, PT, SE), OAPI patent (BF, BJ, CF, CG, CI, CM, GA, GN, ML, MR, NE, SN, TD, TG).  <b>Published</b> <i>With international search report. Before the expiration of the time limit for amending the claims and to be republished in the event of the receipt of amendments.</i></p>

## (54) Title: MEDICAMENT DISPENSING DEVICE

## (57) Abstract

A reservoir (20) for receiving a supply of medicament in powder form, which reservoir has one end portion of a relatively large internal cross-sectional area through which powder can be loaded into the reservoir and an opposite end portion providing a discharge aperture (21) of a relatively small cross-sectional area, wherein the internal cross-sectional area of the reservoir reduces progressively between said one end portion and said opposite end portion so that the relationship between cross-sectional area and the distance from said one end portion towards said opposite end portion, is generally linear.

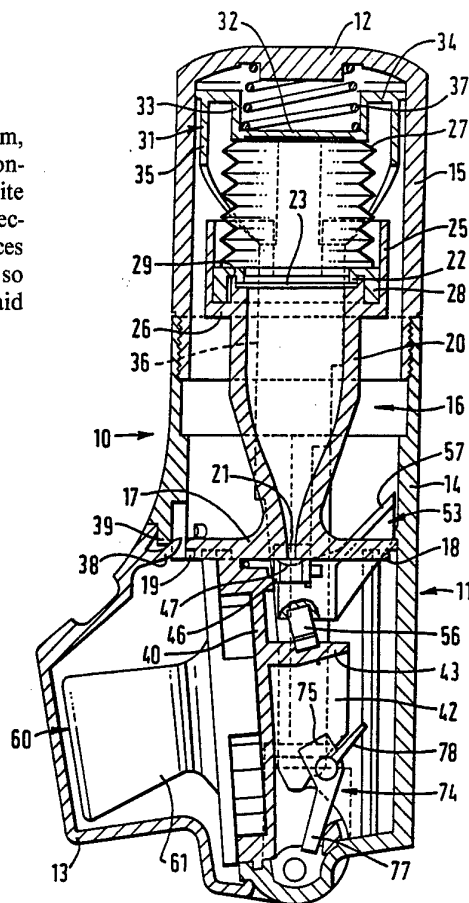

**FOR THE PURPOSES OF INFORMATION ONLY**

Codes used to identify States party to the PCT on the front pages of pamphlets publishing international applications under the PCT.

AT	Austria	FR	France	MR	Mauritania
AU	Australia	GA	Gabon	MW	Malawi
BB	Barbados	GB	United Kingdom	NE	Niger
BE	Belgium	GN	Guinea	NL	Netherlands
BF	Burkina Faso	GR	Greece	NO	Norway
BG	Bulgaria	HU	Hungary	NZ	New Zealand
BJ	Benin	IE	Ireland	PL	Poland
BR	Brazil	IT	Italy	PT	Portugal
BY	Belarus	JP	Japan	RO	Romania
CA	Canada	KP	Democratic People's Republic of Korea	RU	Russian Federation
CF	Central African Republic	KR	Republic of Korea	SD	Sudan
CG	Congo	KZ	Kazakhstan	SE	Sweden
CH	Switzerland	LI	Liechtenstein	SI	Slovenia
CI	Côte d'Ivoire	LK	Sri Lanka	SK	Slovak Republic
CM	Cameroon	LU	Luxembourg	SN	Senegal
CN	China	LV	Latvia	TD	Chad
CS	Czechoslovakia	MC	Monaco	TG	Togo
CZ	Czech Republic	MG	Madagascar	UA	Ukraine
DE	Germany	ML	Mali	US	United States of America
DK	Denmark	MN	Mongolia	UZ	Uzbekistan
ES	Spain			VN	Viet Nam
FI	Finland				

MEDICAMENT DISPENSING DEVICE

This invention relates to a dispensing device, and more specifically, to a device suitable for dispensing discrete amounts of a particulate material entrained in an air flow. In particular, the invention is concerned with a dispensing device of the type where a metered dose is administered on inhalation by a patient.

Metered dose inhalers are well known in medicine for treatment, or alleviation of the effects of respiratory complaints, for example asthma. Many of these devices are for use with a pressurized aerosol dispensing container. However, inhalers for dispensing metered doses of drugs in dry powder form are also known.

US-2,587,215 describes devices having separate drug reservoirs and air mixing chambers in which metered doses of the drug are dispersed in an air stream which is inhaled by a patient. The metering member is in the form of either a slide plate having a metering hole therein for receiving a drug dose, or a rotatable slide member having dose-receiving depressions in its upper surface. EP-0,488,609 similarly describes a slide plate dose metering device.

EP-0,069,715 describes a device in which doses of drugs are transferred by a perforated membrane from a storage reservoir across an air conduit through which air inhaled by a patient is drawn.

EP-0,079,478; EP-0,166,294 and GB-2,165,159 describe devices in which a drug dose is transferred from a storage reservoir to a passage for air inhaled by a patient located immediately beneath the reservoir, in a recess formed in a rotatable metering member positioned between the reservoir and the air passage.

US-4,274,403 describes an inhaler having a rotary metering member with a drug dose receiving aperture therethrough. The metering member is slidable between

positions in which the aperture is aligned with an outlet of a drug storage reservoir for loading a dose of drug into the aperture, and in which it is aligned with an inhalation nozzle. The metering member also has a further passage communicating with the drug receiving aperture therein, the passage being open to the ambient atmosphere when the aperture is aligned with the inhalation nozzle to allow air to be drawn through the aperture and to entrain the drug therein for inhalation by a patient.

WO 92/00771 describes an inhaler having a rotary metering member with drug dose-receiving depressions in its periphery. A dose of drug is loaded in each depression when aligned with a drug storage reservoir. The metering member is rotated to bring a dose laden depression into communication with an air inhalation passage for inhalation of the drug dose by a patient.

WO 92/10229 in our name, describes an inhaler which utilizes a flow of compressed air to fluidize and load powdered medicament contained in a storage reservoir, into a dose metering chamber for inhalation by a patient. A controlled air bleed through the metering chamber is achieved to provide a full dose of drug in the metering chamber.

WO 92/09322 describes an inhaler having a rotatable metering drum for receiving powder doses and for delivering such doses to an inhalation mouthpiece. The device has an air channel communicating with a metered dose in the metering drum for discharging the dose in an air flow inhaled through the mouthpiece.

GB-2,165,159 describes a dosing device which utilizes a storage chamber for a medicinal substance which is generally cylindrical and has a generally conical discharge end.

GB-1,329,415 relates to a vending machine having storage bottles for powdered substances which reduce in cross-sectional area towards the discharge ends thereof.

The object of the invention is to provide improvements in dry powder medicament dispensing devices and component parts thereof to facilitate the operation thereof. It is also an

object to improve the delivery of drug doses so as to achieve more consistency in the metered doses of the drug.

The invention provides a reservoir for receiving a supply of medicament in powder form, which reservoir has one end portion of a relatively large internal cross-sectional area through which powder can be loaded into the reservoir and an opposite end portion providing a discharge aperture of a relatively small cross-sectional area, wherein the internal cross-sectional area of the reservoir reduces progressively between said one end portion and said opposite end portion so that the relationship between cross-sectional area and the distance from said one end portion towards said opposite end portion, is generally linear.

The aspect ratio of the reservoir (overall height/largest internal diameter) is preferably in the range of substantially 2:1 to substantially 5:1. The aspect ratio may be substantially 3:1.

An air permeable wall member may be provided at said one end portion of the reservoir to retain powdered medicament within the reservoir.

The cross-sectional area of said discharge aperture is preferably in the range of from substantially  $0.2 \text{ mm}^2$  to substantially  $13 \text{ mm}^2$ , e.g. in the range of from substantially  $0.2 \text{ mm}^2$  to  $3.5 \text{ mm}^2$ .

The invention also provides metering apparatus for dispensing a dose of medicament in powder form, comprising a reservoir structure including a reservoir for receiving a supply of medicament in powder form and a movable metering element having a metering cavity to receive a dose of medicament contained, in use, in the reservoir, wherein the cross-sectional area of a metering apparatus of the reservoir structure, which discharges into said metering cavity, is in the range of  $0.2 \text{ mm}^2$  to  $13 \text{ mm}^2$ . The cross-sectional area of the discharge aperture may be in the range of from  $0.2 \text{ mm}^2$  to  $3.5 \text{ mm}^2$ .

The invention further provides a method of metering a dose of medicament in powder form, comprising applying a fluid

pressure to a volume of such medicament in a reservoir which progressively decreases in internal cross-sectional area from one relatively large end portion thereof to an opposite end portion which provides a relatively small discharge aperture, so that the powder is discharged through said discharge aperture into a dose receiving cavity of a dose metering member at a velocity in the range of from substantially 5 m/s to substantially 35 m/s.

The invention further provides metering apparatus for dispensing a dose of medicament in powder form, comprising a reservoir for receiving a supply of medicament in powder form, which reservoir decreases in internal cross-sectional area from one relatively large end portion thereof to an opposite end portion which provides a relatively small discharge aperture, means for applying a fluid pressure to said one end portion of the reservoir, and a fluid permeable wall-member at said one end portion of the reservoir to retain powdered medicament within the reservoir. Said fluid pressure applying means may be in the form of a fluid chamber which is expandable or contractible to alter in the internal volume thereof.

An embodiment of the invention will now be described by way of example and with reference to the accompanying drawings, in which:-

Figure 1 is a vertical section through a dry powder inhaler embodying the invention;

Figure 2 is an exploded view, on a reduced scale, of the inhaler of Figure 1;

Figure 3 is a vertical cross-section through a hopper unit of the inhaler of Figs. 1 and 2.

Figure 4 illustrates a relationship between the internal cross-sectional area and the vertical distance from the top of the hopper, in respect of a hopper in accordance with the present invention;

Figures 5 and 6 are diagrammatic sectional details of the hopper and mouthpiece assembly of the inhaler illustrating the air flows therethrough;

Figures 7 and 8 are, respectively, a sectional side view and an end view of the mouthpiece assembly;

Figure 9 is a diagrammatic representation of a resilient cam track portion provided on a yoke assembly of the inhaler; and

Figures 10A-10F are diagrammatic illustrations of different hopper cross-sections tested by the inventors.

Referring to the drawings, the inhaler (10) comprises a hollow substantially cylindrical body (11) which is closed at its upper end by a cap portion (12) and has a hinged mouthpiece cover (13) which normally closes an aperture in a lower portion of the side wall of the cylindrical body (11). The body (11) comprises a lower case portion (14) on which the mouthpiece cover (13) is hingedly mounted, and an upper case closed portion (15). The general construction and operation of the inhaler is described in our British Patent Applications Nos. 9218937.2 and 9218978.6, the disclosures of which are incorporated herein by reference, and to which reference is directed for further details.

The hopper unit (16), for containing a supply of a drug in powdered form, is located within the body part (11). The hopper unit (16) is formed with a reservoir (20) for containing a supply of the powdered drug. The upper end of the wall of the reservoir (20) is formed to seat a circular disc (23) which is air permeable.

A bellows (27) comprises a corrugated wall having a closed upper end and having at its lower end an integral sealing ring (28) for locating with the upper end of the wall of the reservoir (20) in contact with the air filter disc (23).

To complete the upper assembly of the powder dispensing apparatus, a yoke member (31) is located on and in contact with the top of the bellows (27). A compression spring (37) is held in compression with the top case part (15). In order to maintain the compression spring in its compressed state while the mouthpiece cover (13) is in its closed position, thereby preventing dispensing of a dose of powdered medicament

from the reservoir (20), the yoke member (31) has a pair of downwardly depending elongate limbs (36), the lower ends of which cooperate with cam portions (70,71) formed integrally with the cover (13) as described below.

The hopper assembly (16) is formed with a channel (45) open at either end for the passage of air therethrough. The channel (45) is also downwardly open along the underside of the base plate portion (17) of the hopper unit.

A dose dispensing slide unit (44) comprises a slide member (46) having a dose receiving depression (47) formed in an upper surface thereof. The slide plate is maintained in contact with the underside of the base plate (17) of the hopper unit for sliding movement between a first position in which the dose receiving depression (47) is located beneath the outlet orifice (21) of the drug reservoir (20) and a second position in which the depression (47) containing the dose of drug is placed in a primary air mixing chamber provided by the channel (45) in the hopper unit base plate (17). The slide (46) is in the form of a narrow plate with the depression (47) formed in its upper surface. At one end of the slide, a pair of spaced transverse walls (48,49) project upwardly and are received in a slot in the hopper base plate (17). The slide (46) also has a laterally projecting peg (50). The slide (46) is spring biased to its second position in which its depression (47) is placed in the primary mixing chamber (45), by a leaf spring (51), one end of the spring being located in the slot defined between the walls (48,49) of the slide and the other end of the leaf spring being fixed to an outer side wall portion of the reservoir (20).

The slide member (46) is mounted on a slide carrier (53) which has in its upper surface a channel (54) in which the slide member (46) is slidably mounted and in its lower surface a recess (55) for receiving a biasing spring (56). The slide mounting (53) has an upwardly projecting narrow flange (57) which defines with a lower portion of the side wall of the



reservoir (20) an inlet air passage to the primary mixing chamber (45).

The contact between the slide member (46) and the base plate (17) and a leg portion (40) of the hopper unit is such that pressurized air can bleed therebetween without permitting the passage of the powdered drug therebetween. This is a feature of the method of loading a dose of drug into the metering depression (47) in the slide plate.

A further element of the device is an integral mouthpiece and cyclone unit (60). The mouthpiece section (61) communicates with a secondary air and powder mixing chamber (62). Referring to Figs. 5 and 6, the mixing chamber (62) comprises a cyclone having four equi-angularly spaced tangential air inlets (63) arranged in an annulus around the mixing chamber. The uppermost tangential inlet passage (63) communicates with the primary mixing chamber (45) whilst the remaining three tangential inlets allow air to be drawn therethrough into the cyclone on inhalation through the mouthpiece (61).

The mouthpiece cover (13) is hingedly mounted to the bottom wall of the lower case part (14). Opposite sides of the mouthpiece at its hinged parts, are formed with respective cam formations (70 and 71). At one side of the cover, a circular cam (70) is formed in association with the cover hinge (72) for cooperation with the lower end of one of the downwardly extending limbs (36) of the yoke member (31). As the cover opens, the cam moves to a position to allow the yoke to drop in order to cause actuation of the drug dispensing mechanism as described below.

At the opposite side of the cover, the cam (71) cooperates with a resilient pivotally mounted trigger mechanism (74) which cooperates with the other limb (36) of the yoke member (31). The trigger (74), which is pivotally mounted on the lower casing part (14) comprises three radially extending portions, a first relatively thick portion (75) against which the end of the corresponding yoke limb (36) locates, a second narrower portion (77) for engaging with the

cam (71) and a third narrower and more flexible portion (78) which resiliently abuts against the side wall of the lower case part (14) for resetting the trigger. In the closed position of the cover, the yoke is maintained in its upper position by engagement with the first trigger projection (75), the trigger being maintained in this position by engagement of the second trigger portion (77) with an abutment surface (78) on the cam (71). As the cover is opened, the cam (71) is rotated anti-clockwise until a second abutment surface (79) thereof engages the trigger portion (77) sufficiently to release the trigger portion (75), with a snap action, from its engagement supporting the yoke limb (36) which is thereby allowed to drop under the action of biasing spring (37) acting on the yoke. The third trigger portion (78) is then resiliently deformed against the side wall of the lower case so that when the cover is closed again and the yoke is lifted to its upper position by rotation of the cam (70), the trigger is resiliently reset to its original position in engagement with the lower end of the corresponding yoke limb (36).

In order to control the action of the slide (46), one of the yoke limbs (36) is formed with a laterally projecting, resiliently mounted cam portion (80) having a three dimensional, generally triangular cam track (81) provided thereon (Figure 9). The peg (50) formed on the side of the slide member (46) engages in the cam track (81). The slide (46) is held in its initial position against the action of biasing spring (51), when the yoke member is in its upper position with the mouthpiece cover (13) in its closed position, with the peg (50) at the lower end of the vertical portion of the cam track (81). When the mouthpiece cover (13) is opened sufficiently to allow the yoke to move downwardly under the action of spring (36), the cam moves downwardly with respect to the peg (50) until peg (50) moves to the upper end of the vertical portion (81A) of the cam track (81) allowing, on further opening of the cover (13), the spring (51) to move the slide (46) laterally to its second position during which the peg (50) moves along the horizontal top portion (81B) of

the cam track (81). After a drug dispensing operation and when the cover (13) is again moved towards its closed position so that the yoke is lifted, the cam then moves upwardly in relation to the peg (50) so that the peg (50) then moves along the slanted portion (81C) of the cam track (81) to bring the slide (46) back towards its initial position against the action of its biasing spring (51).

The operation of the device is generally as follows. When the cover (13) is open sufficiently to release the trigger (47), the yoke (31) is moved downwardly under the action of its biasing spring (36). This causes the bellows (27) to be compressed which results in air being forced through the supply of powdered drug (90) located in the reservoir (20). The air flow fluidizes the powdered drug and entrains the drug so as to fill the metering depression (47) in the slide (46). This filling operation is effected by providing an air bleed between the slide (46) and the engaging portions of the hopper unit (16) to maintain an air flow through the dose receiving depression (47) thereby effectively filling that depression with powdered drug.

The slide is moved to its second position under the action of spring (51) whereby the dose laden depression (47) is brought into the primary mixing chamber (45). On inhalation at the mouthpiece (61), air is drawn through the primary mixing chamber (45) causing turbulence around the drug laden depression (47) in the slide (46) which draws the dose of drug into the air stream in the primary mixing chamber (45). Continued inhalation draws the air and powdered drug mixture through the upper tangential air inlet (63) into the second cyclone mixing chamber (62) as well as drawing further swirling air flows through the other three tangential air inlets (63) of the cyclone. The thoroughly mixed air and powdered drug is then inhaled by the patient.

After use, the mouthpiece cover (13) is closed thereby lifting the yoke (35) and causing the slide (46) to be moved back to its initial position as the peg (50) thereof is moved along the slanted portion (81C) of the cam track of cam (81)

as described above. The device is then ready for another drug dispensing operation.

Suitable drugs or drug blends which may be used in an inhaler described above may include salbutamol, beclomethasone dipropionate, budesonide and sodium cromoglycate.

The internal shape of the reservoir (20) is important in order to achieve reliable metering. To achieve this, it is necessary to maintain the bulk properties of the drug in the reservoir during the dispensing of, for example, 200 doses. The shape of a reservoir according to the invention avoids the common problems of coring (when the bulk powder movement produces a hole from top to bottom allowing air to pass without powder movement) and bridging where the powder will not pass through a narrower part of the hopper causing horizontal voids in the bulk.

When the bellows (27) is compressed, an air flow is forced through the narrow exit and the velocity is increased which results in improved metering reliability. It has been found that there is a critical exit velocity for given drugs in powdered form, e.g. with Salbutamol this has been found to be around 15 m/s, below which there is bulk density fluctuation in the metered powder and much above this, the powder becomes impacted onto the surface of the dosing slide member (46) which makes mixing with the air stream difficult. A practical range for operation of this metering principle work has been found to be in the range of from about 5 m/s to about 35 m/s.

Experiments have shown that reducing the diameter to 0.5 mm results in poor metering whereas increasing the size to 2.0 mm has a less marked effect. The aperture cross-sectional area is therefore in the range of about 0.2 mm<sup>2</sup> to about 3.14 mm<sup>2</sup> (or say about 3.5 mm<sup>2</sup>). The hopper exit diameter needs to be optimised for different blends, e.g. Salbutamol 1.0 mm diameter, Sodium Cromoglycate 1.5 mm diameter. An optimum practical range for the hopper exit is 0.5 mm to 4.0 mm diameter or equivalent cross-sectional area, namely about 0.2 mm<sup>2</sup> to about 13 mm<sup>2</sup>.

In other embodiments, the powder dispensing outlet cross-sectional area may be reduced to the above stated range at a point downstream of the hopper where the powder is dispensed into the volumetric metering cavity.

It has also been found by experimentation that the optimum internal shape of the hopper is a cross-section which reduces progressively from a large diameter top portion to a small exit aperture, in accordance with a relationship between the internal cross-sectional area of the hopper and the vertical height thereof, which is close to a linear relationship as illustrated in Fig. 4. The relationship is therefore close to  $x = z^2$ , where  $x$  is the vertical height in the hopper and  $z^2$  is the corresponding internal cross-sectional area of the hopper. In this respect, the inventors tested various shapes for the cross-section of the hopper, as illustrated in Figures 10A-10F. The inventors also tested a hopper in accordance with the above-mentioned relationship and found, unexpectedly, that it achieved a better performance, in particular, in reducing the tendency of "coring" and "bridging" as described above, so as to deliver consistently a full dose of powder under an air fluidisation dose delivery system as described above. In effect the whole hopper shape at its outlet end portion is a smoothly tapering nozzle which has been found to give a beneficial fluid behaviour of the hopper for use with a pneumatic fluidizing effect as utilized in the present inhaler device.

To this end the hopper aspect ratio (as defined by height over large diameter) is most preferably around 3:1. Generally it has been found that hoppers having aspect ratios of less than 2:1 or greater than 5:1 do generally not work without coring or bridging occurring.

The filter system used to divide the hopper from the air pumping system is also most advantageous to the device. Without the filter the bulk powder is free to move around a system of around twice its nominal volume which results in the requirement for a gross overfill to achieve the nominal dose output. This also leads to reliability problems towards the

end of the product life as inversion of the device allows a by now small amount of powder to migrate away from the dosing nozzle with the result of no dose being dispensed. Experiments with different mesh sizes for the filter from a nominal  $15\mu\text{m}$  hole size to  $110\mu\text{m}$  have been made. These represent the outer useful envelopes for powders with a nominal particle diameter of  $30\text{-}60\mu\text{m}$ . If the powder is agglomerated into larger particles which could be up to  $200\mu\text{m}$  in diameter, the effective mesh range would increase correspondingly. At the small end of the mesh scale the filter then represents a serious pressure drop to the driving air system and, at around say  $2\mu\text{m}$  nominal hole size, it is difficult to achieve the high exit velocity required to achieve effective metering.

CLAIMS

1. A reservoir for receiving a supply of medicament in powder form, which reservoir has one end portion of a relatively large internal cross-sectional area through which powder can be loaded into the reservoir and an opposite end portion providing a discharge aperture of a relatively small cross-sectional area, wherein the internal cross-sectional area of the reservoir reduces progressively between said one end portion and said opposite end portion so that the relationship between cross-sectional area and the distance from said one end portion towards said opposite end portion, is generally linear.

2. A reservoir according to Claim 1 wherein the aspect ratio of the reservoir (overall height/largest internal diameter) is in the range of substantially 2:1 to substantially 5:1.

3. A reservoir according to Claim 2 wherein the aspect ratio is substantially 3:1.

4. A reservoir according to any one of Claims 1 - 3, wherein an air permeable wall member is provided at said one end portion of the reservoir to retain powdered medicament within the reservoir.

5. A reservoir according to any one of Claims 1 - 4, wherein the cross-sectional area of said discharge aperture is in the range of from substantially  $0.2 \text{ mm}^2$  to substantially  $13. \text{ mm}^2$ .

6. A reservoir according to Claim 5 wherein the cross-sectional area of the discharge aperture is in the range of from substantially  $0.2 \text{ mm}^2$  to  $3.5 \text{ mm}^2$ .

7. Metering apparatus for dispensing a dose of medicament in powder form, comprising a reservoir structure including a reservoir for receiving a supply of medicament in powder form and a movable metering element having a metering cavity to receive a dose of medicament contained, in use, in the reservoir, wherein the cross-sectional area of a metering aperture of the reservoir structure, which discharges into said metering cavity, is in the range of 0.2 mm<sup>2</sup> to 13 mm<sup>2</sup>.

8. Metering apparatus according to Claim 7 wherein the cross-sectional area of the discharge aperture is in the range of from 0.2 mm<sup>2</sup> to 3.5 mm<sup>2</sup>.

9. A method of metering a dose of medicament in powder form, comprising applying a fluid pressure to a volume of such medicament in a reservoir which progressively decreases in internal cross-sectional area from one relatively large end portion thereof to an opposite end portion which provides a relatively small discharge aperture, so that the powder is discharged through said discharge aperture into a dose receiving cavity of a dose metering member at a velocity in the range of from substantially 5 m/s to substantially 35 m/s.

10. Metering apparatus for dispensing a dose of medicament in powder form, comprising a reservoir for receiving a supply of medicament in powder form, which reservoir decreases in internal cross-sectional area from one relatively large end portion thereof to an opposite end portion which provides a relatively small discharge aperture, means for applying a fluid pressure to said one end portion of the reservoir, and a fluid permeable wall-member at said one end portion of the reservoir to retain powdered medicament within the reservoir.

11. Metering apparatus according to Claim 10, wherein said fluid pressure applying means is in the form of a fluid



chamber which is expandable or contractible to alter in the internal volume thereof.

12. A medicament dispensing device having a reservoir according to any one of Claims 1 - 6, or metering apparatus according to any one of Claims 7, 8, 10 and 11.

FIG. 1

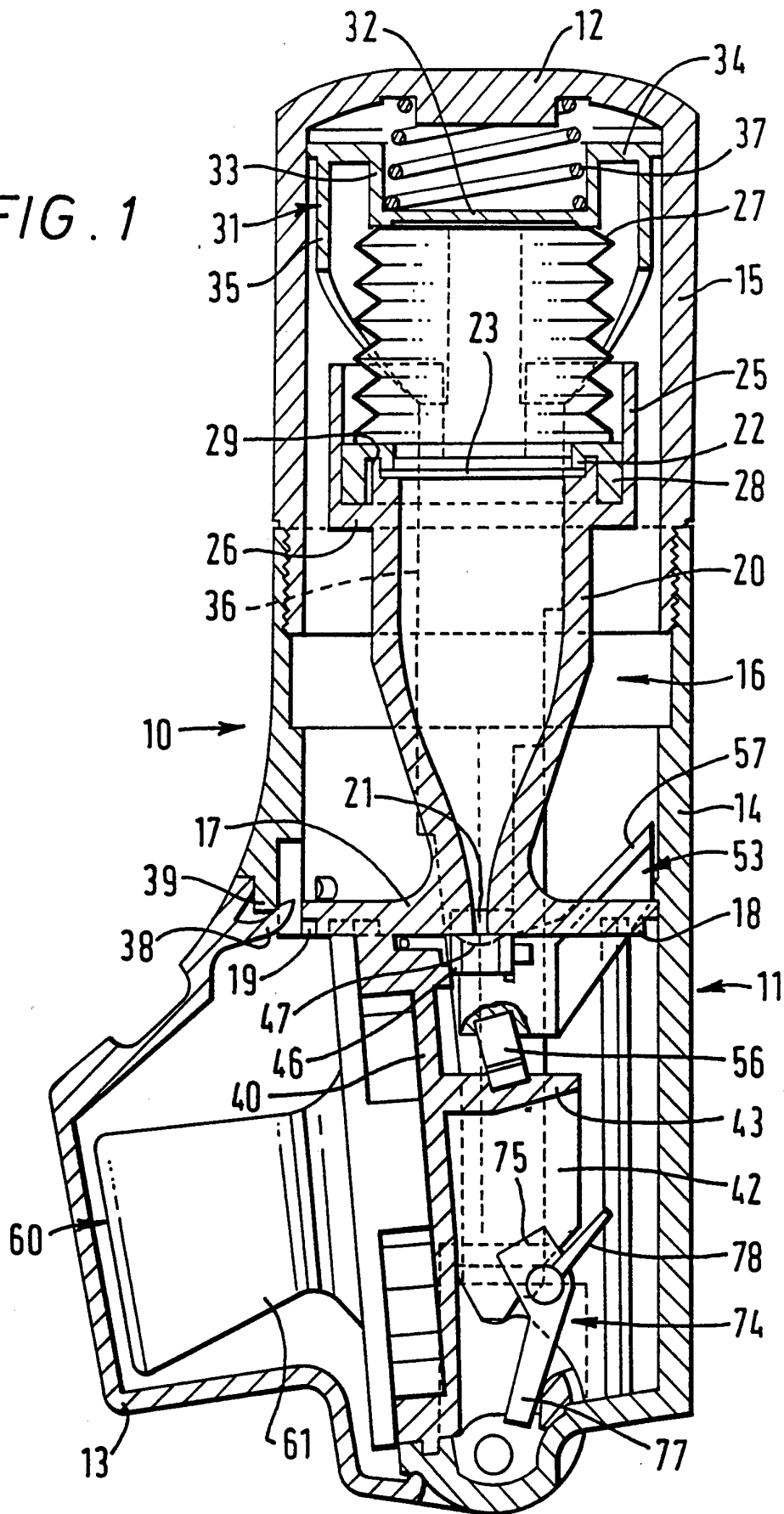

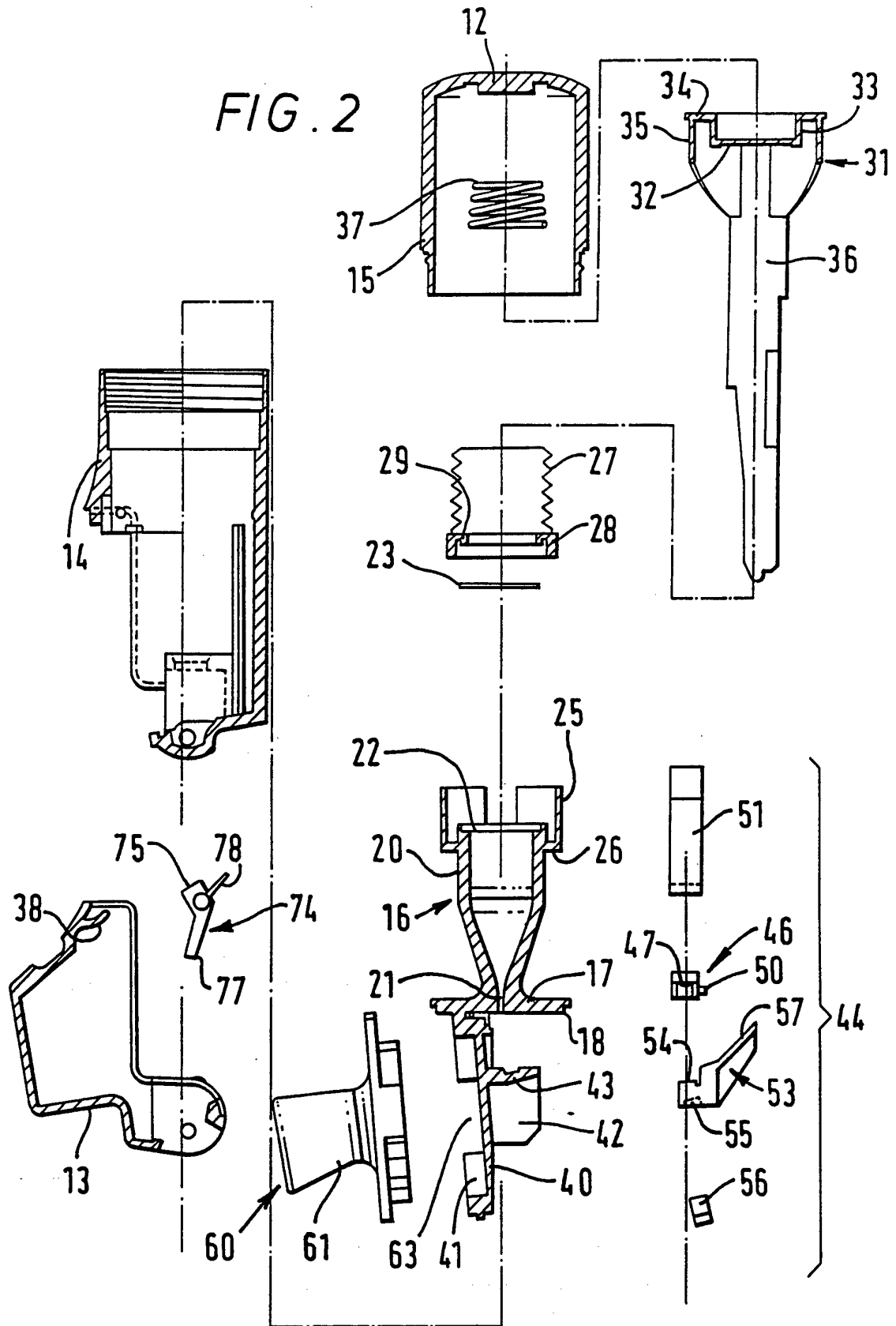

FIG. 3

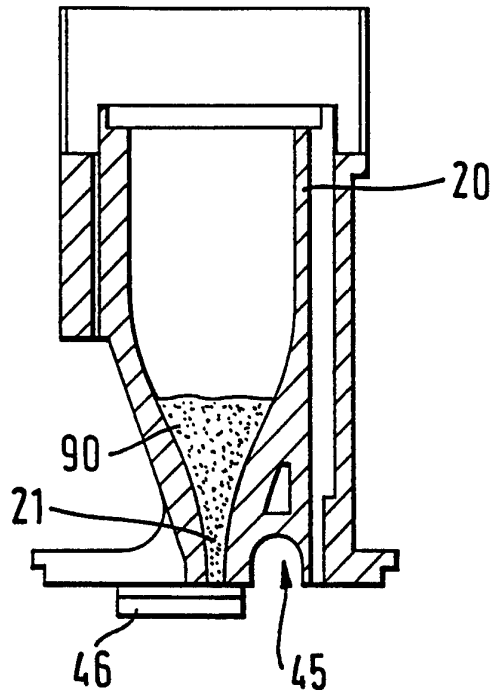
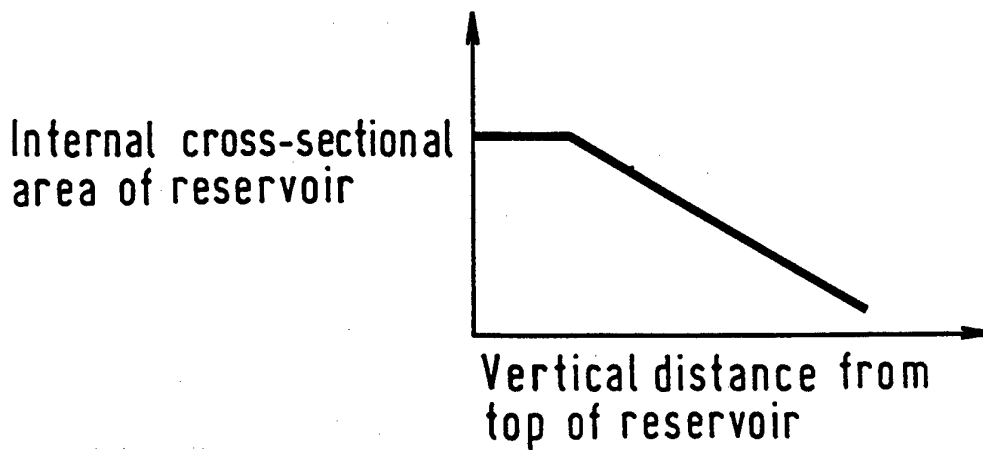

FIG. 4



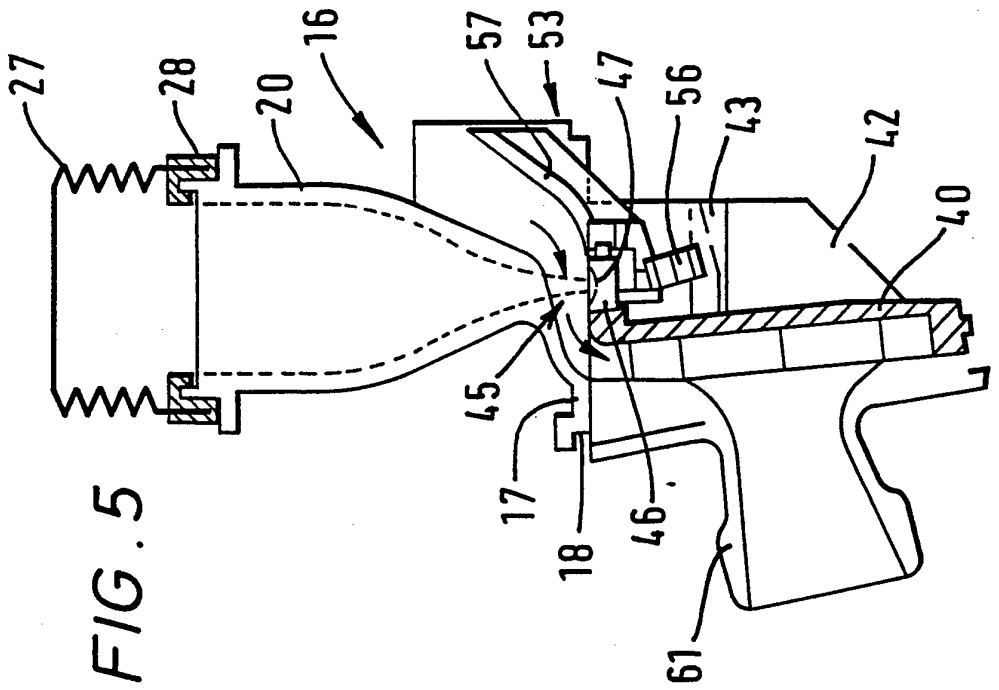
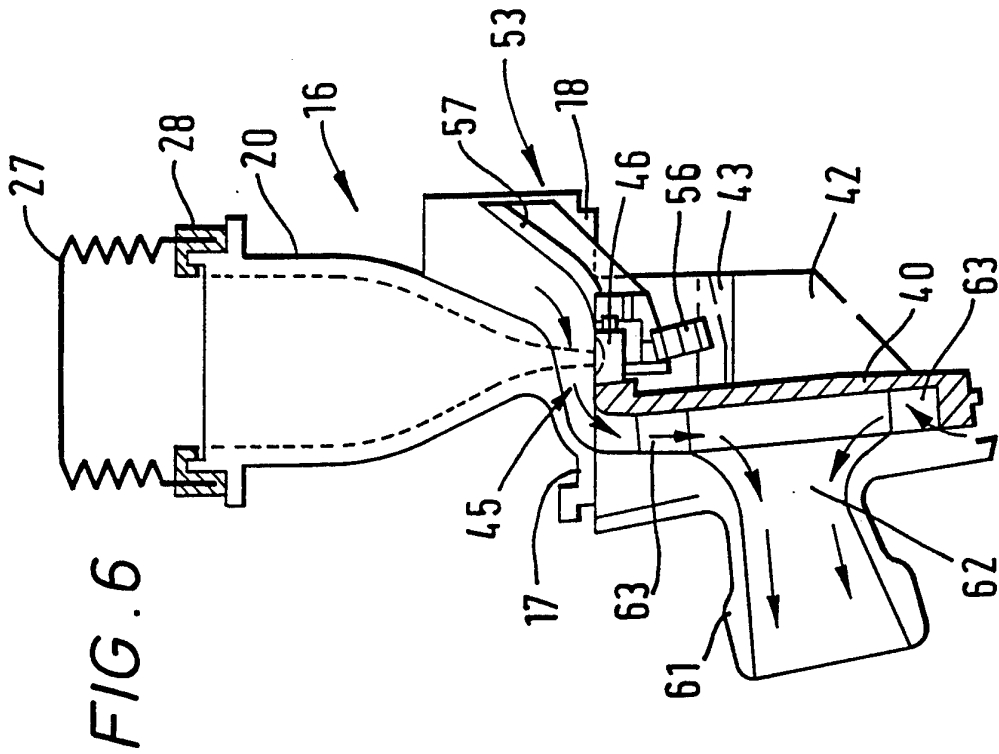

FIG. 7

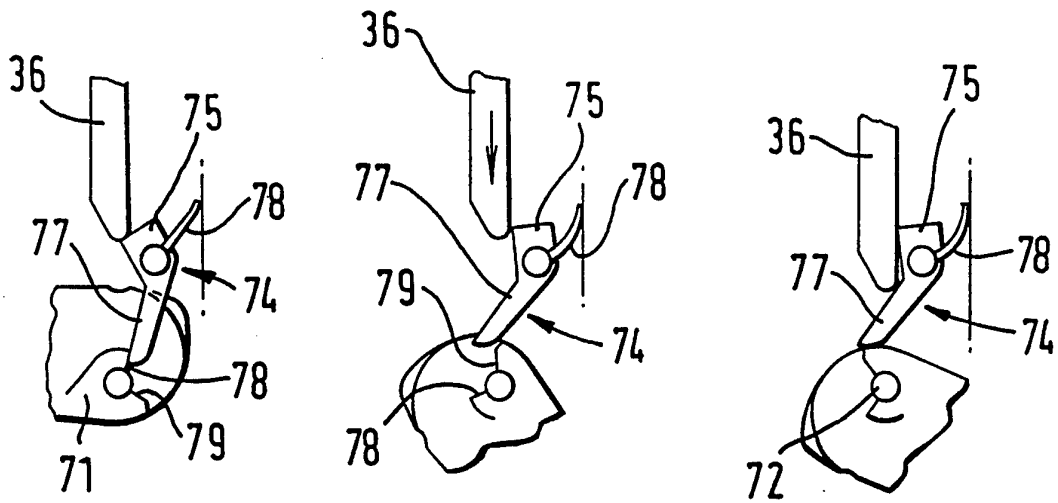

FIG. 8

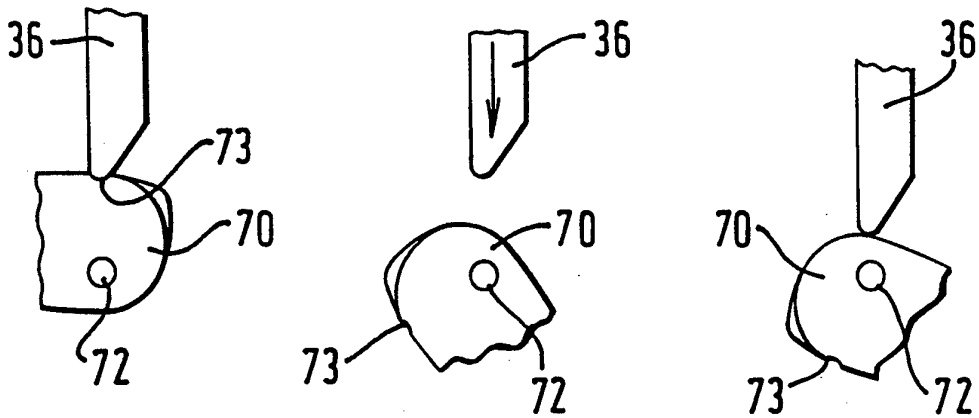

FIG. 9 .

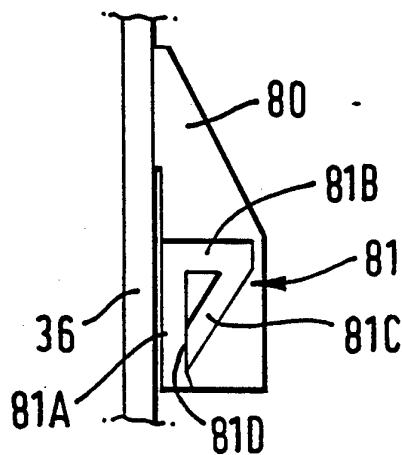

FIG. 10A

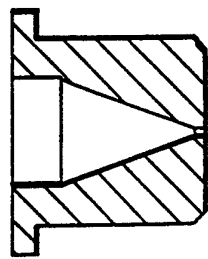

FIG. 10B

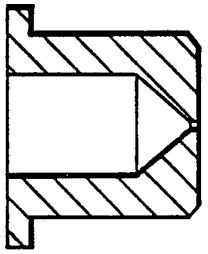

FIG. 10C

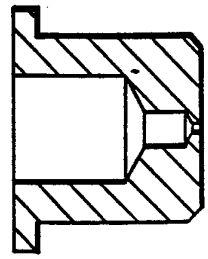
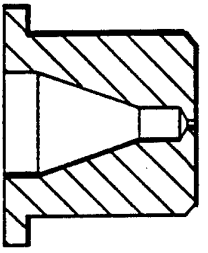

FIG. 10D

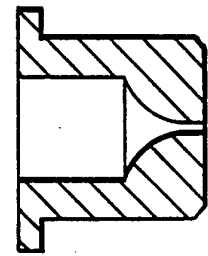

FIG. 10E

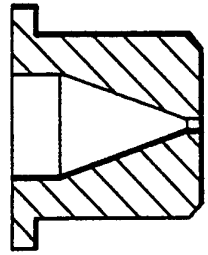

FIG. 10F

## INTERNATIONAL SEARCH REPORT

International Application No.  
PCT/GB 93/01894

## A. CLASSIFICATION OF SUBJECT MATTER

IPC 5 A61M15/00

According to International Patent Classification (IPC) or to both national classification and IPC

## B. FIELDS SEARCHED

Minimum documentation searched (classification system followed by classification symbols)

IPC 5 A61M

Documentation searched other than minimum documentation to the extent that such documents are included in the fields searched

Electronic data base consulted during the international search (name of data base and, where practical, search terms used)

## C. DOCUMENTS CONSIDERED TO BE RELEVANT

Category *	Citation of document, with indication, where appropriate, of the relevant passages	Relevant to claim No.
X	WO,A,92 09322 (BOEHRINGER INGELHEIM KG) 11 June 1992 cited in the application	1,7,8
Y	see page 5, line 7 - line 20; figures ---	9-11
Y	WO,A,92 10229 (NORTON HEALTHCARE LTD.) 25 June 1992 cited in the application see abstract; figures ---	9-11
A	EP,A,0 424 790 (MIAT SPA) 2 May 1991 see claim 1; figures ---	1,7,9,10
A	US,A,5 113 855 (NEWHOUSE) 19 May 1992 -----	

Further documents are listed in the continuation of box C.

Patent family members are listed in annex.

## \* Special categories of cited documents:

- "A" document defining the general state of the art which is not considered to be of particular relevance
- "E" earlier document but published on or after the international filing date
- "I" document which may throw doubts on priority claim(s) or which is cited to establish the publication date of another citation or other special reason (as specified)
- "O" document referring to an oral disclosure, use, exhibition or other means
- "P" document published prior to the international filing date but later than the priority date claimed

- "T" later document published after the international filing date or priority date and not in conflict with the application but cited to understand the principle or theory underlying the invention
- "X" document of particular relevance; the claimed invention cannot be considered novel or cannot be considered to involve an inventive step when the document is taken alone
- "Y" document of particular relevance; the claimed invention cannot be considered to involve an inventive step when the document is combined with one or more other such documents, such combination being obvious to a person skilled in the art.
- "&" document member of the same patent family

Date of the actual completion of the international search

23 December 1993

Date of mailing of the international search report

07.01.94

Name and mailing address of the ISA

European Patent Office, P.B. 5818 Patentlaan 2  
NL - 2280 HV Rijswijk  
Tel. (- 31-70) 340-2040, Tx. 31 651 epo nl,  
Fax: (+ 31-70) 340-3016

Authorized officer

Villeneuve, J-M



## INTERNATIONAL SEARCH REPORT

information on patent family members

International Application No.

PCT/GB 93/01894

Patent document cited in search report	Publication date	Patent family member(s)		Publication date
WO-A-9209322	11-06-92	AU-A-	8844391	25-06-92
		CN-A-	1062847	22-07-92
		EP-A-	0559663	15-09-93
-----				
WO-A-9210229	25-06-92	AU-A-	8932691	08-07-92
		CA-A-	2091366	16-06-92
		CN-A-	1062297	01-07-92
		EP-A-	0561838	29-09-93
-----				
EP-A-0424790	02-05-91	AU-B-	625927	16-07-92
		AU-A-	6498790	02-05-91
		CA-A-	2028192	28-04-91
		JP-A-	3184563	12-08-91
		US-A-	5033463	23-07-91
-----				
US-A-5113855	19-05-92	US-A-	5201308	13-04-93
-----				