



US009271097B2

(12) **United States Patent**
Quan

(10) **Patent No.:** **US 9,271,097 B2**
(45) **Date of Patent:** **Feb. 23, 2016**

(54) **METHOD AND APPARATUS TO EVALUATE AUDIO EQUIPMENT VIA FILTER BANKS**

(71) Applicant: **Ronald Quan**, Cupertino, CA (US)

(72) Inventor: **Ronald Quan**, Cupertino, CA (US)

(*) Notice: Subject to any disclaimer, the term of this patent is extended or adjusted under 35 U.S.C. 154(b) by 132 days.

(21) Appl. No.: **13/907,821**

(22) Filed: **May 31, 2013**

(65) **Prior Publication Data**

US 2014/0355774 A1 Dec. 4, 2014

(51) **Int. Cl.**
G01R 23/20 (2006.01)
H04R 29/00 (2006.01)

(52) **U.S. Cl.**
CPC **H04R 29/00** (2013.01); **H04R 29/008** (2013.01); **H04R 2430/03** (2013.01)

(58) **Field of Classification Search**
CPC G01R 23/20; G01R 27/28
USPC 324/620-624
See application file for complete search history.

(56) **References Cited**

U.S. PATENT DOCUMENTS

2,625,614 A	1/1953	Schelling	
2,929,989 A *	3/1960	Hurvitz	324/624
2,970,258 A	1/1961	Sinclair	
4,028,622 A *	6/1977	Evans et al.	324/624
4,246,535 A	1/1981	Huang et al.	
4,258,314 A	3/1981	Hirata	
4,273,970 A	6/1981	Favin et al.	
4,648,113 A	3/1987	Hom et al.	

4,673,888 A	6/1987	Engelmann et al.
5,093,636 A	3/1992	Higgins et al.
5,159,440 A	10/1992	Hong
5,420,516 A	5/1995	Cabot
5,475,315 A	12/1995	Cabot
5,644,243 A	7/1997	Reinhardt et al.
5,644,495 A	7/1997	Soutar et al.
5,818,240 A	10/1998	Cabot
5,915,029 A	6/1999	Yazurlo et al.
6,229,316 B1	5/2001	Fukul et al.
6,385,435 B1	5/2002	Lee
6,405,147 B1	6/2002	Fera
6,452,467 B1	9/2002	McEwan
6,493,024 B1	12/2002	Hartley et al.
6,836,240 B1	12/2004	Dubbert et al.
7,113,606 B2	9/2006	Botti et al.
7,944,297 B2	5/2011	Chen et al.
2004/0193977 A1	9/2004	Kejariwal et al.

OTHER PUBLICATIONS

Cordell, Robert R., *A MOSFET Power Amplifier with Error Correction*, Regional Ball Operating Companies, Central Services Organization, Holmdel, NJ, presented at the 72nd Convention of the Audio Engineering Society, Anaheim, CA, Oct. 23-27, 1982, 16 pages.

(Continued)

Primary Examiner — Vincent Q Nguyen
(74) *Attorney, Agent, or Firm* — George B. Almeida

(57) **ABSTRACT**

A testing method or apparatus utilizes filter banks to measure time varying or dynamic harmonic distortion or intermodulation distortion. With a stairstep signal and filter banks, Nth order harmonic and or intermodulation distortion is measured via the filter banks at different offsets provided by an arbitrary low frequency signal. An amplifier with crossover distortion will show increased harmonic and or intermodulation distortion near the zero crossing while providing less distortion in other portions of the transfer curve of the amplifier.

20 Claims, 26 Drawing Sheets

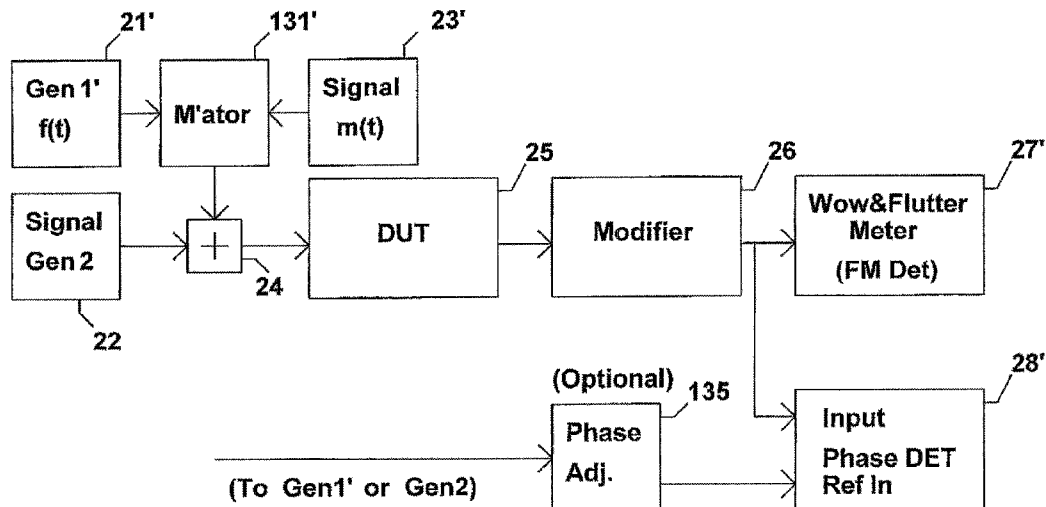

(56)

References Cited

OTHER PUBLICATIONS

Cordell, Robert R., *Phase Intermodulation Distortion—Instrumentation and Measurements Results*, Bell Laboratories, Holmdel, NJ, presented at the 70th Convention of the Audio Engineering Society, New York, NY, Oct. 30-Nov. 2, 1981, 40 pages.

Craig, Margaret, *Television Measurements—NTSC Systems*, Tektronix, May 1994, pp. 7, 25-26, 29, 37-42, 47-60, and 70-72.

Jones, Douglas L., Collection Editor, *The DFT, FFT, and Practical Spectral Analysis*, Feb. 2007, pp. 23-35.

Metzler, Bob, *Measurement of Non-Linearity*, Audio Precision Audio Measurement Handbook, Audio Precision, Inc., Aug. 1993, pp. 23-59.

Leinonen, E., Ojala, M., Curl, J., *A Method for Measuring Transient Intermodulation Distortion (TIM)*, Journal of the Audio Engineering Society, vol. 25, No. 4, Apr. 1977, pp. 170-177.

Wow & Rutter Meter Instruction Manual, Leader Electronics Corp., Hauppauge, NY, 1990, 18 pages.

* cited by examiner

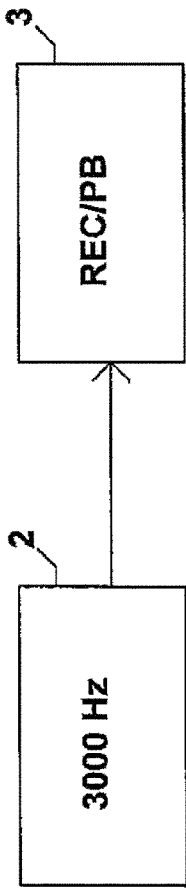

Figure 1A (PRIOR ART)

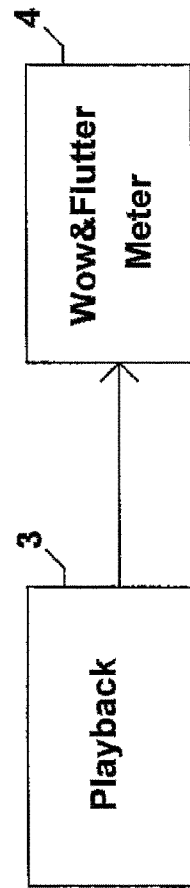

Figure 1B (PRIOR ART)

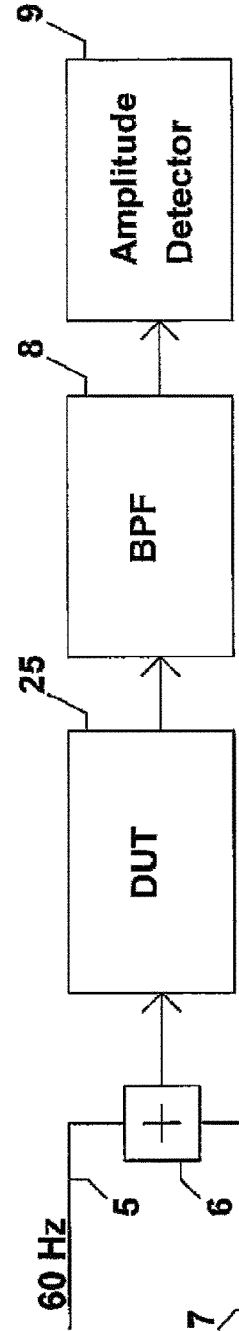

Figure 1C (PRIOR ART)

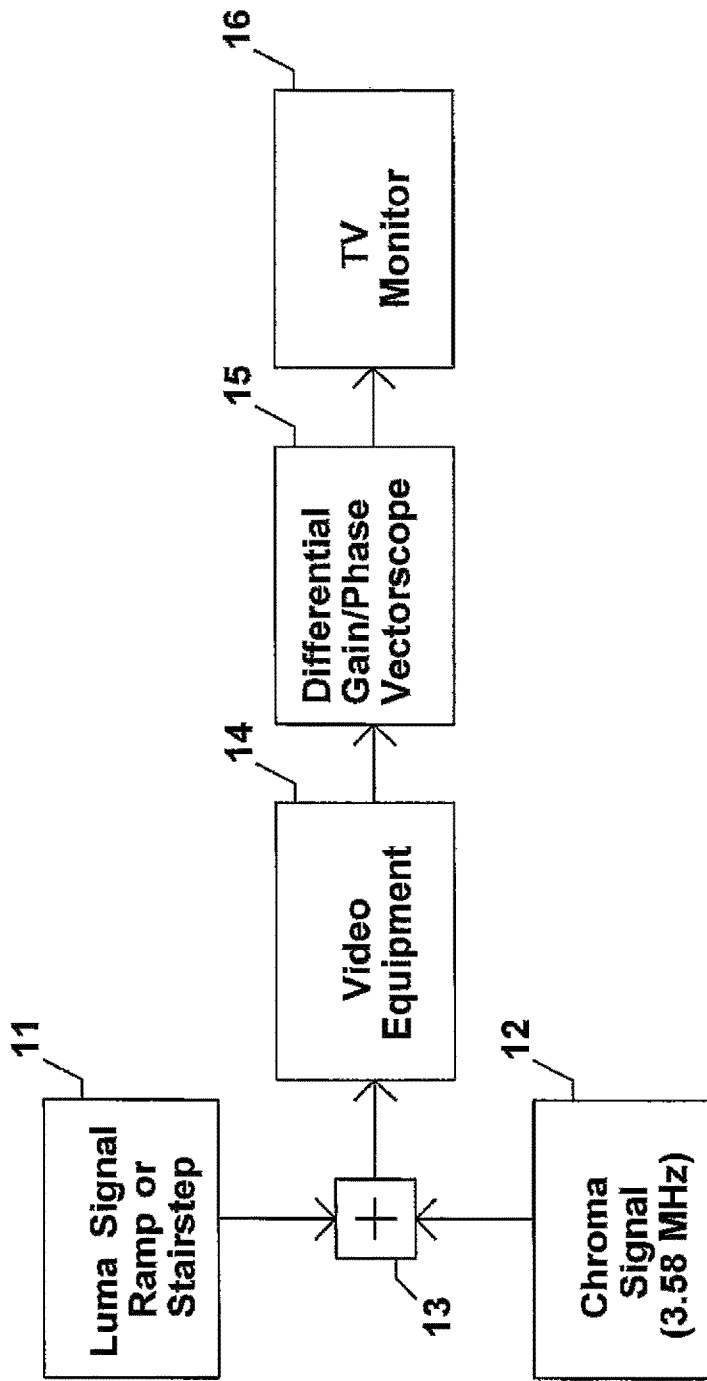

Figure 2 (PRIOR ART)

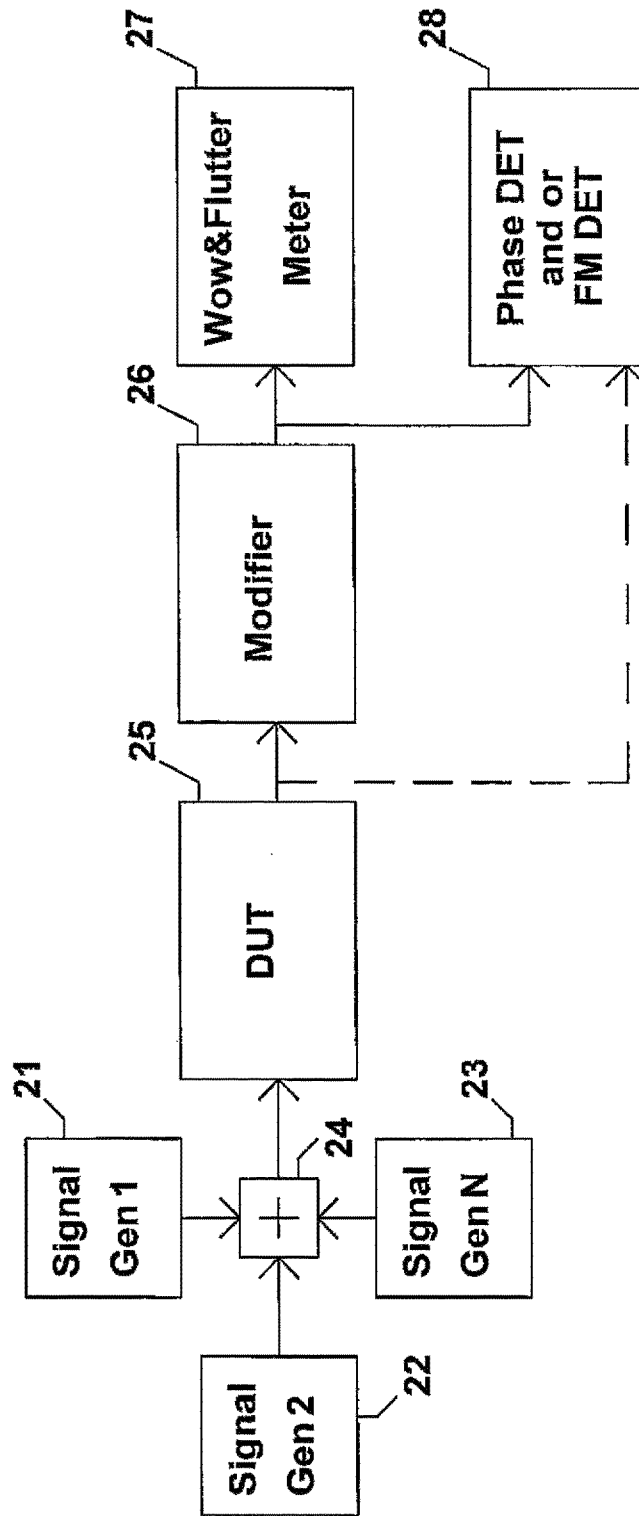

Figure 3

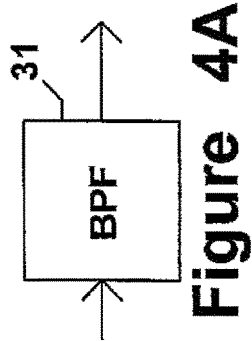

Figure 4A

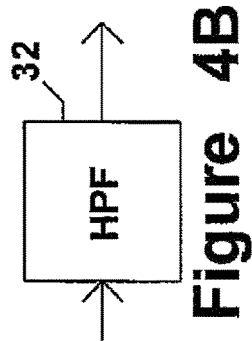

Figure 4B

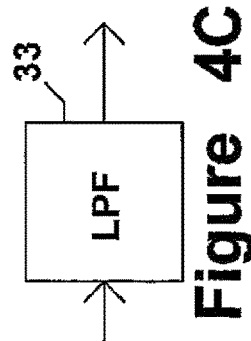

Figure 4C

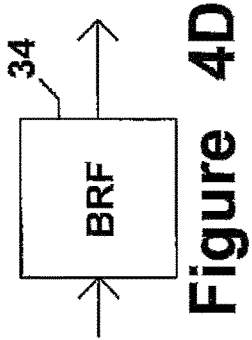

Figure 4D

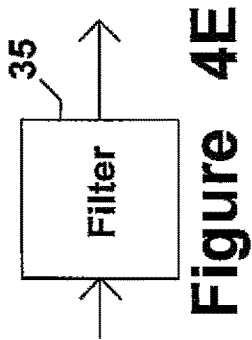

Figure 4E

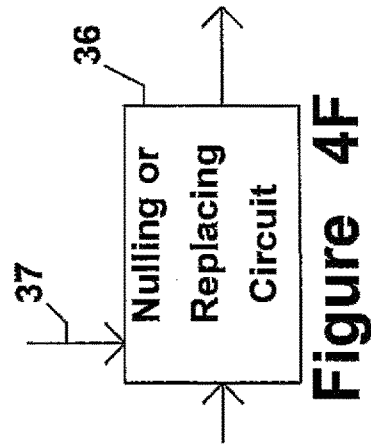

Figure 4F

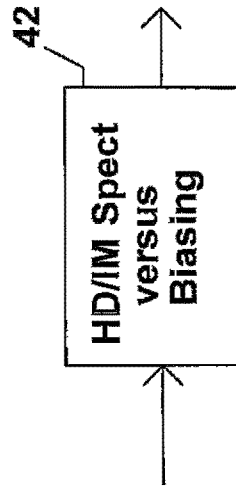

Figure 6

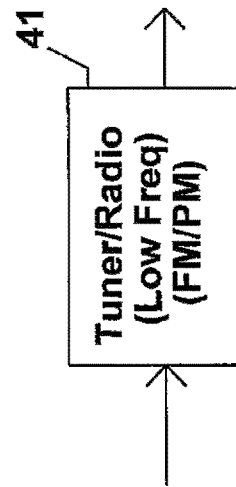

Figure 5

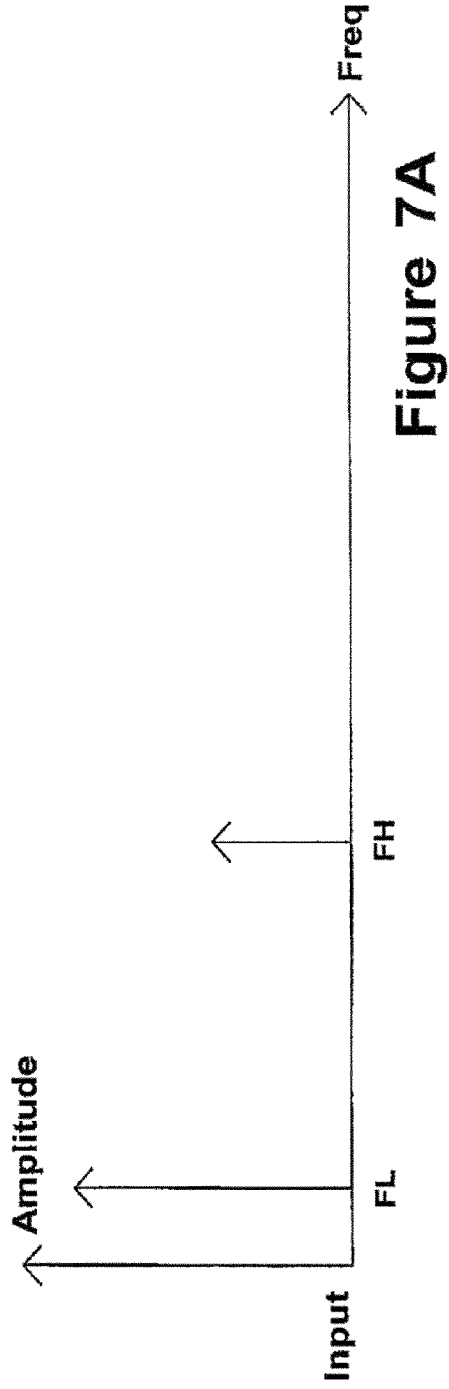

Figure 7A

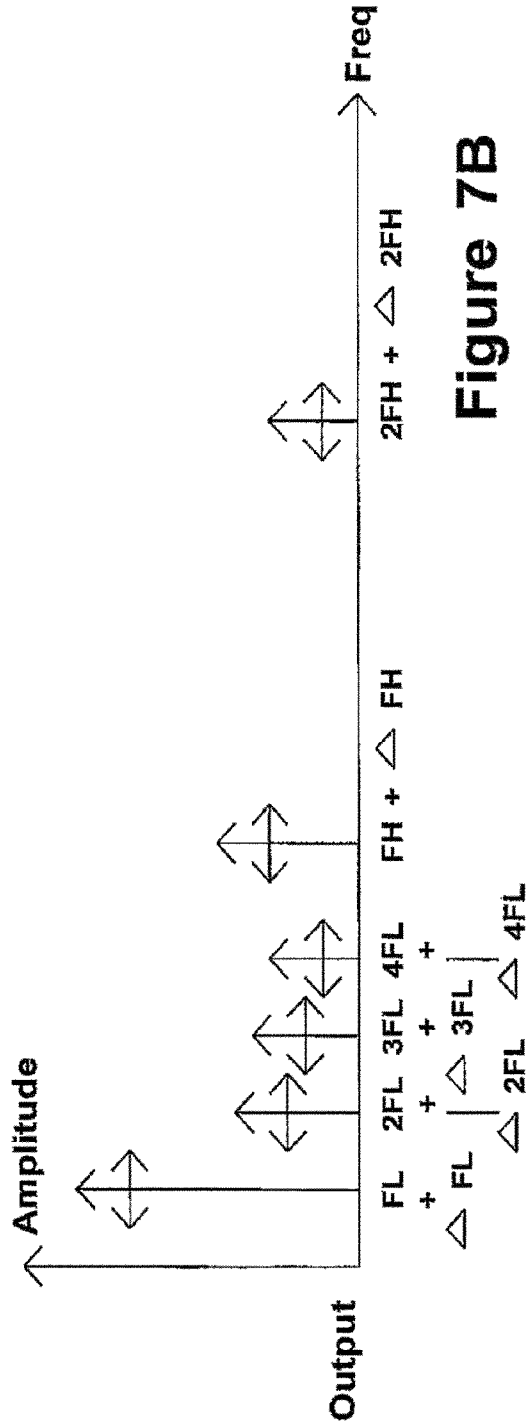
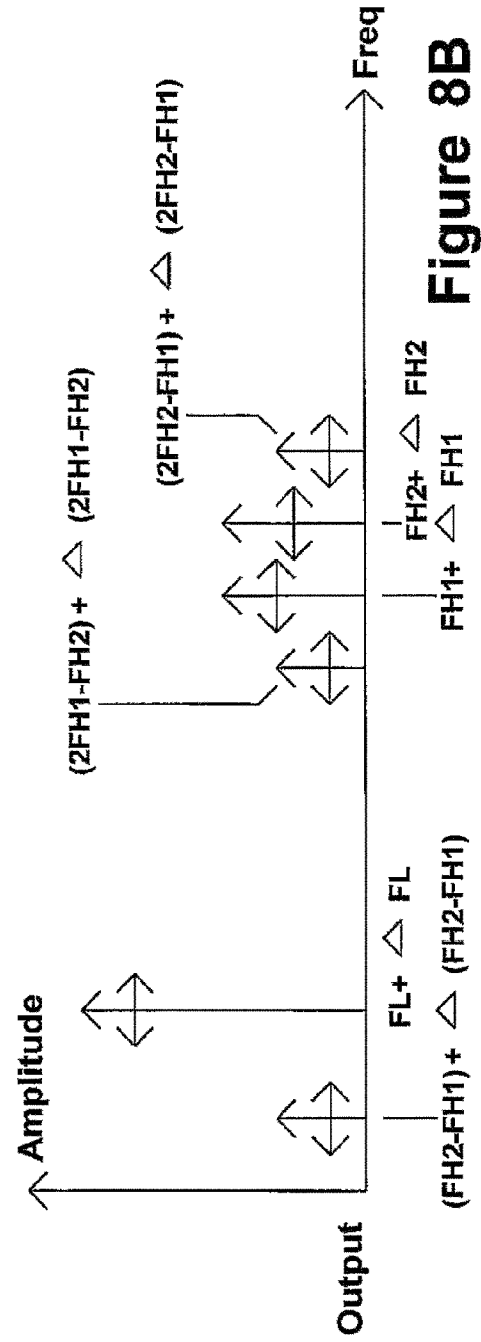
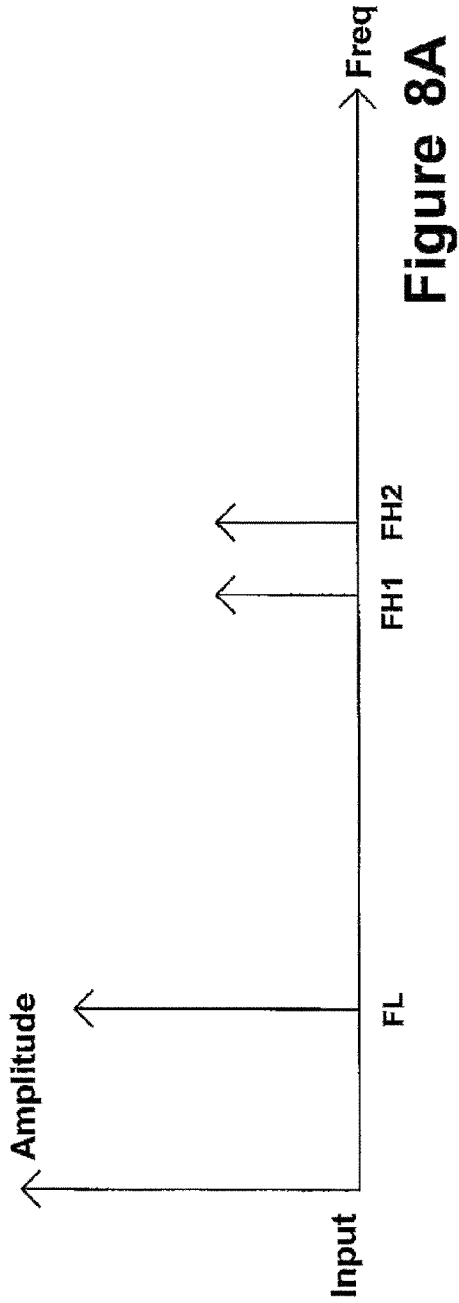
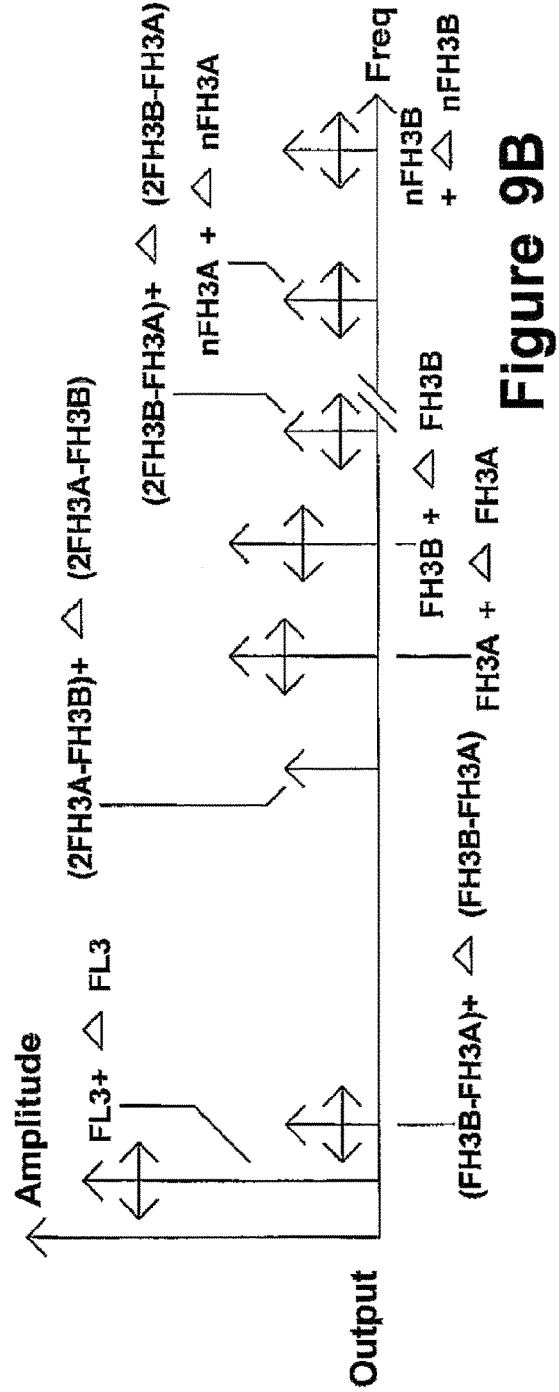
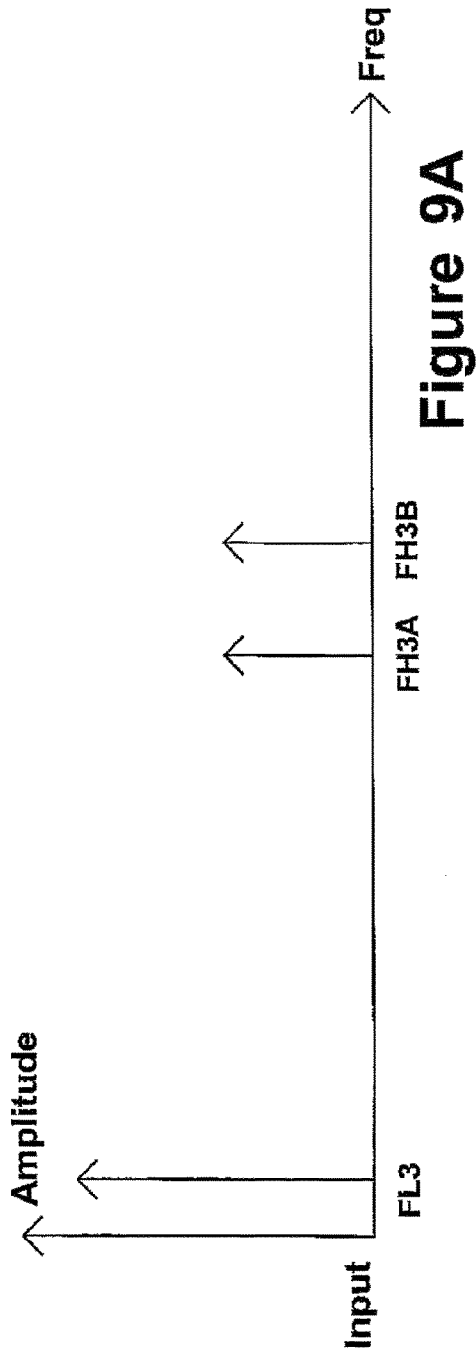

Figure 7B





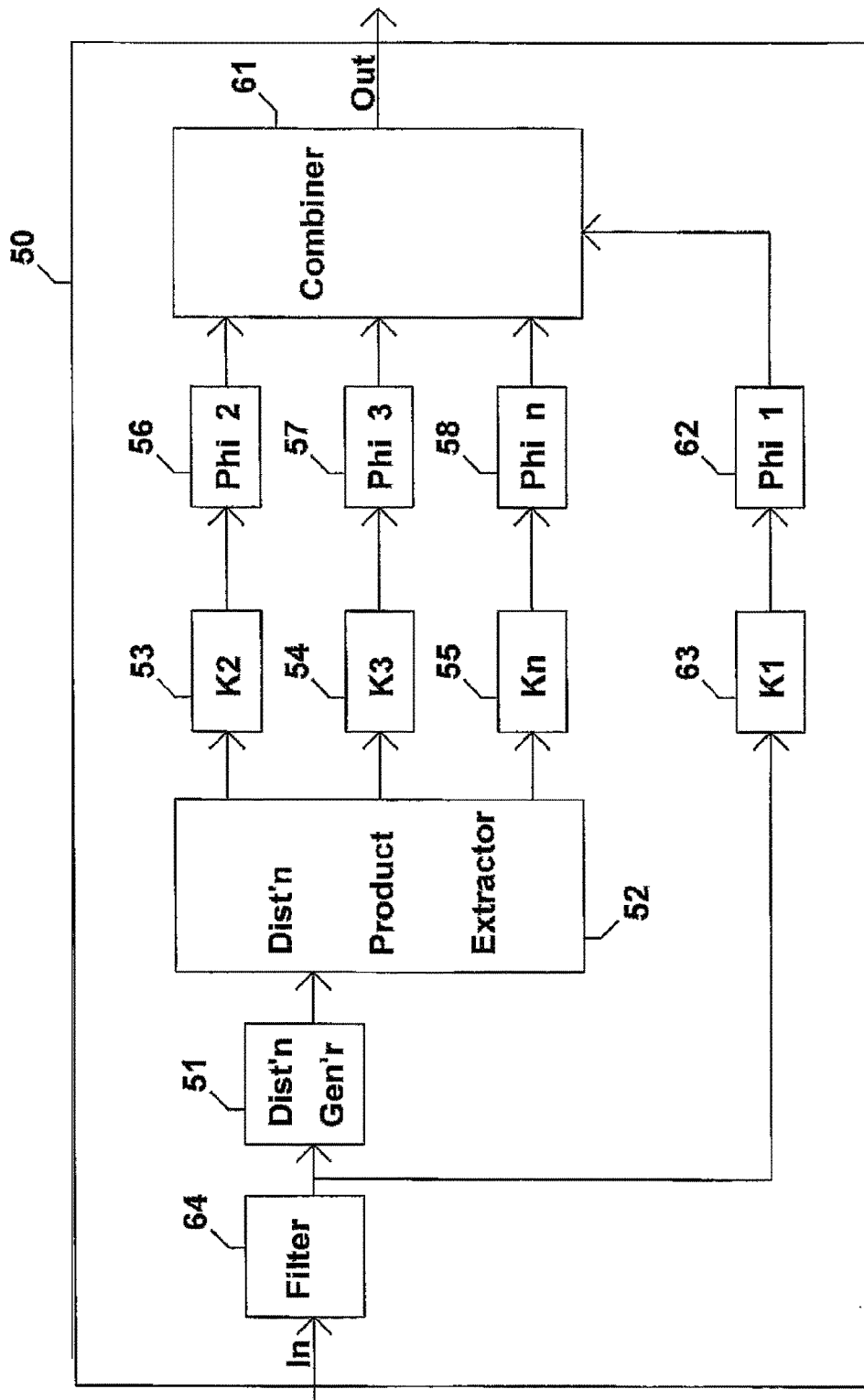

Figure 10

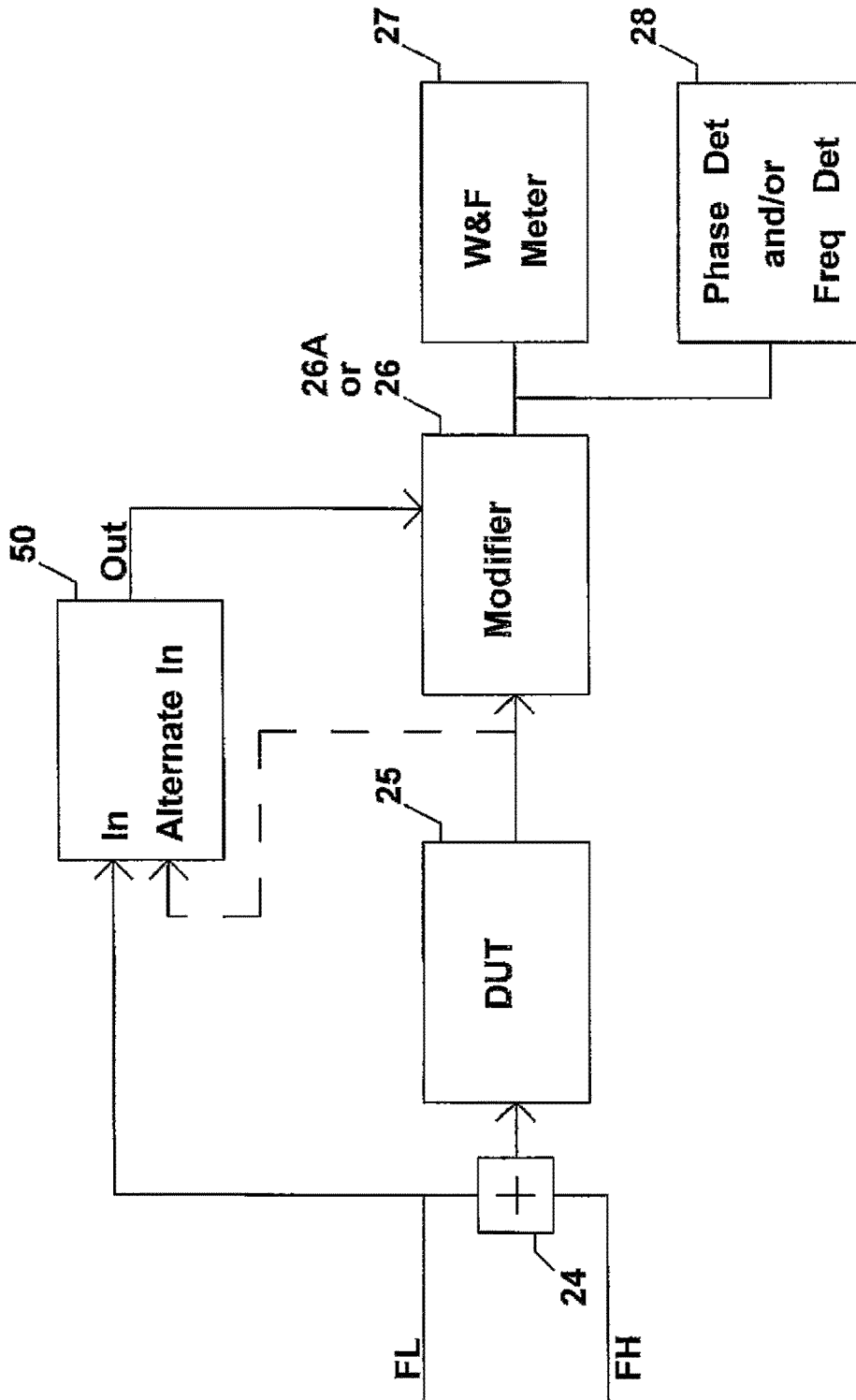

Figure 11

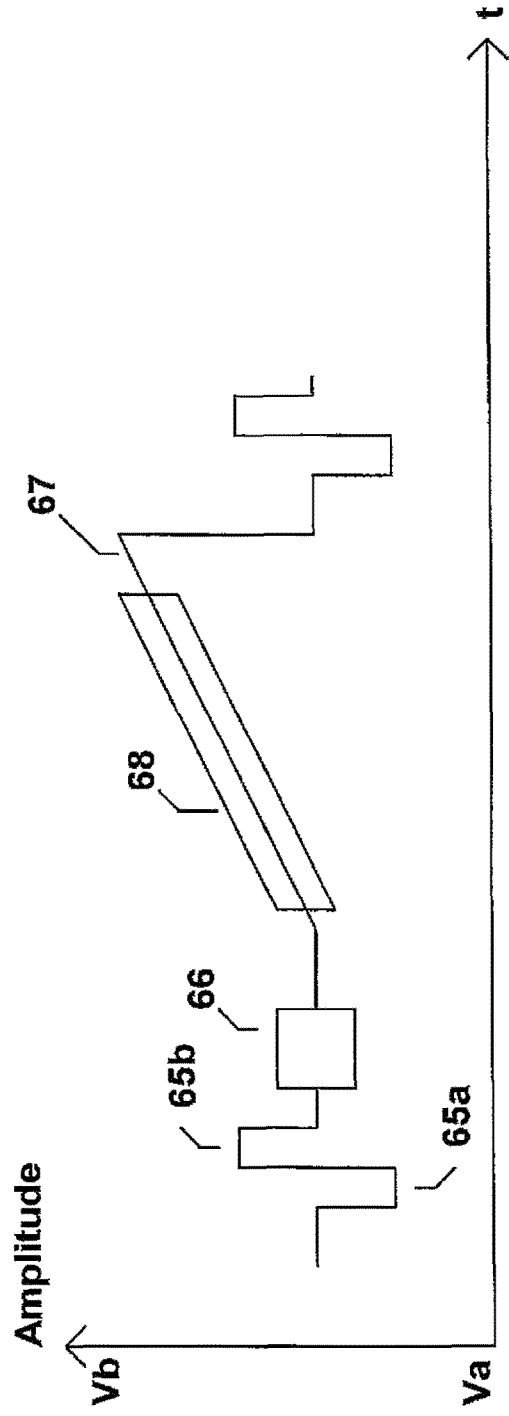

Figure 12

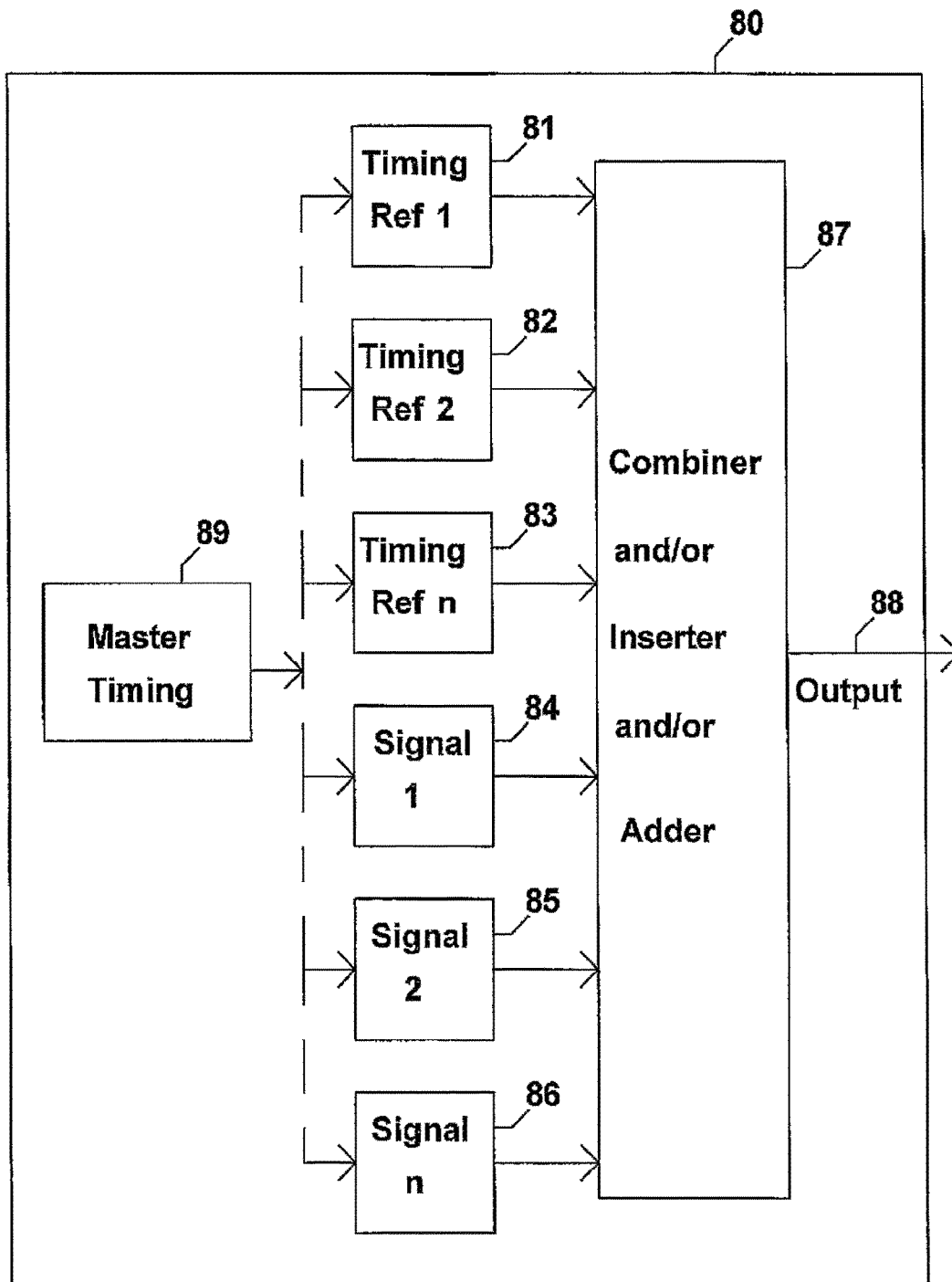

Figure 13

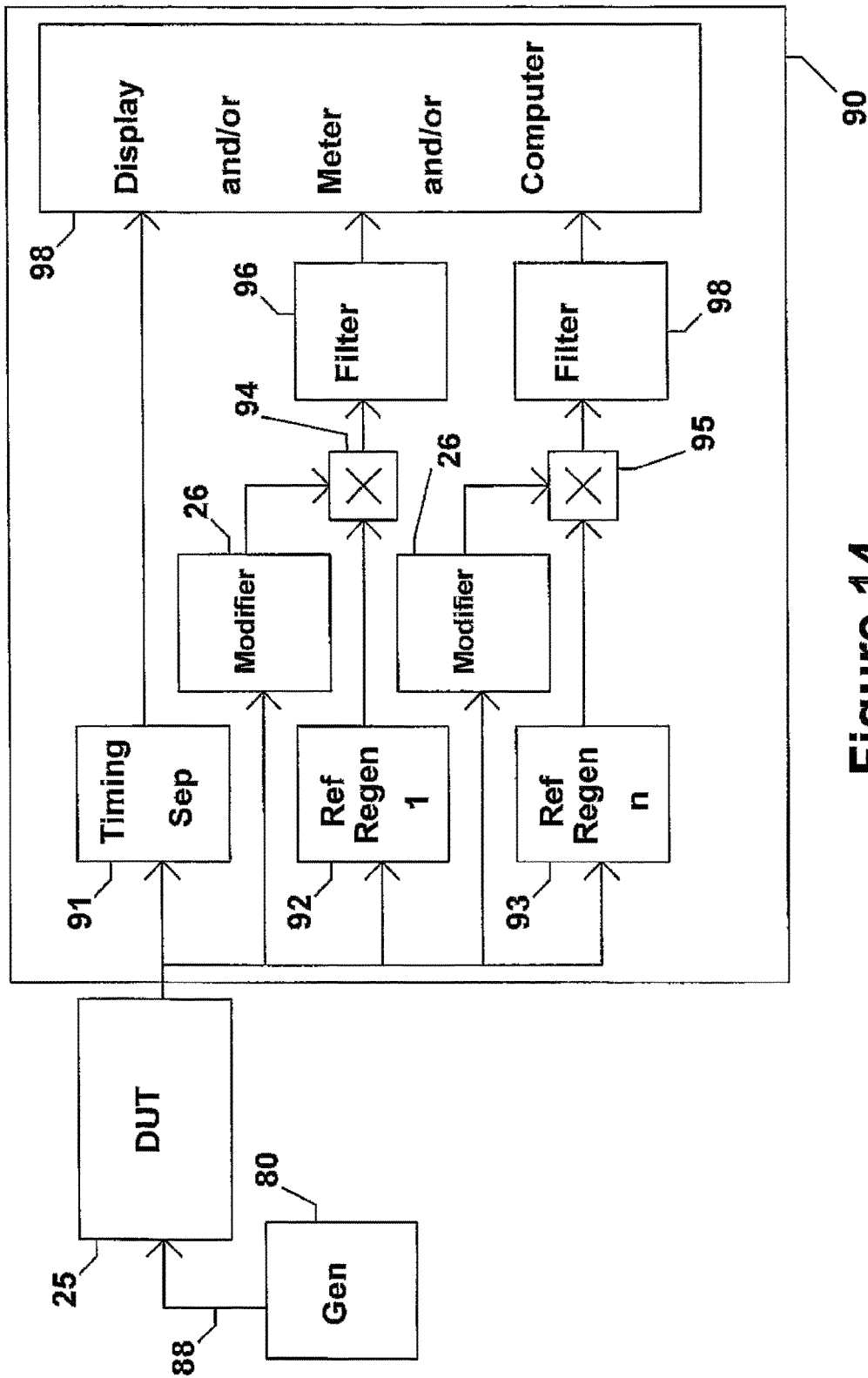

Figure 14

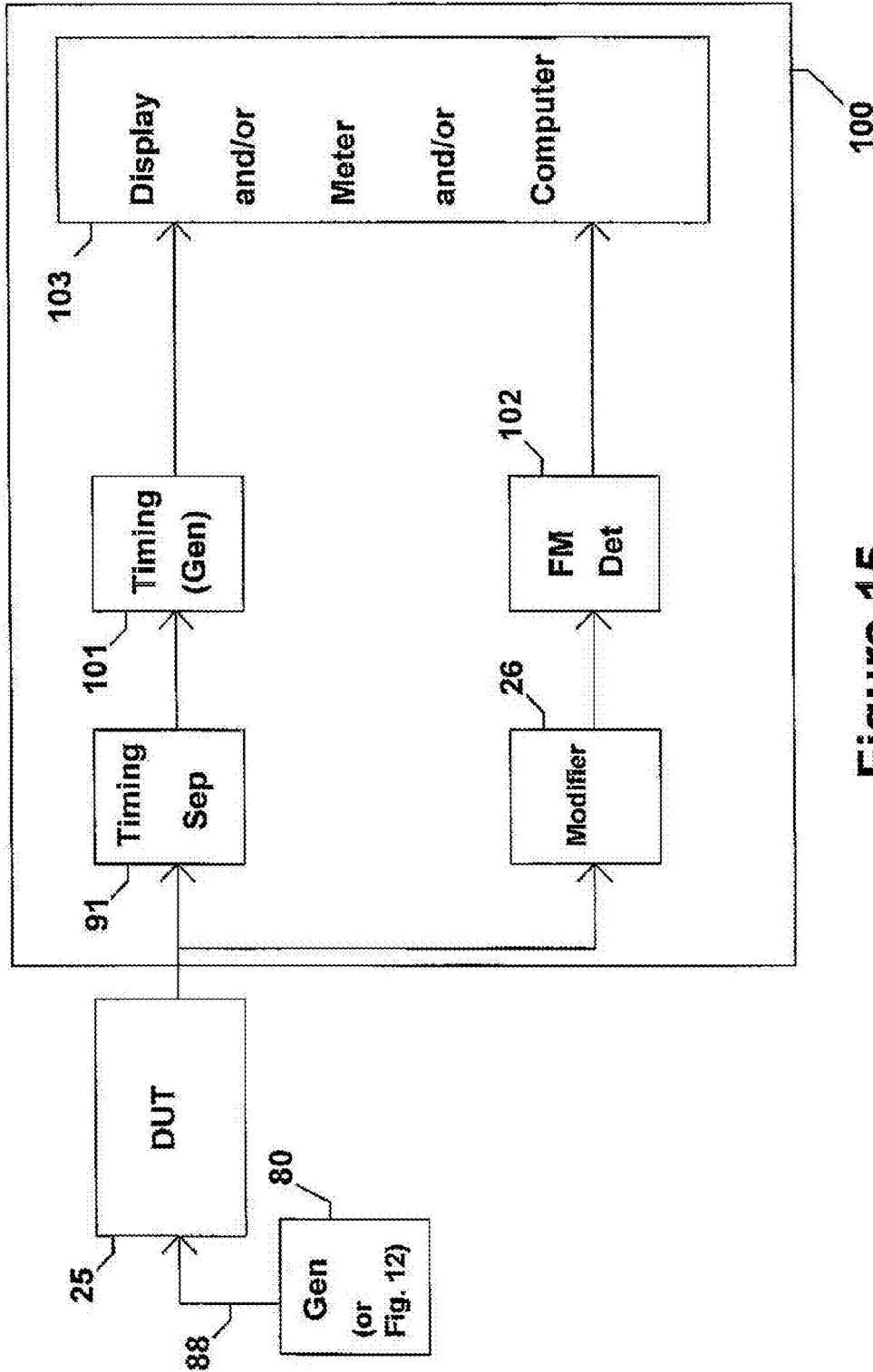

Figure 15

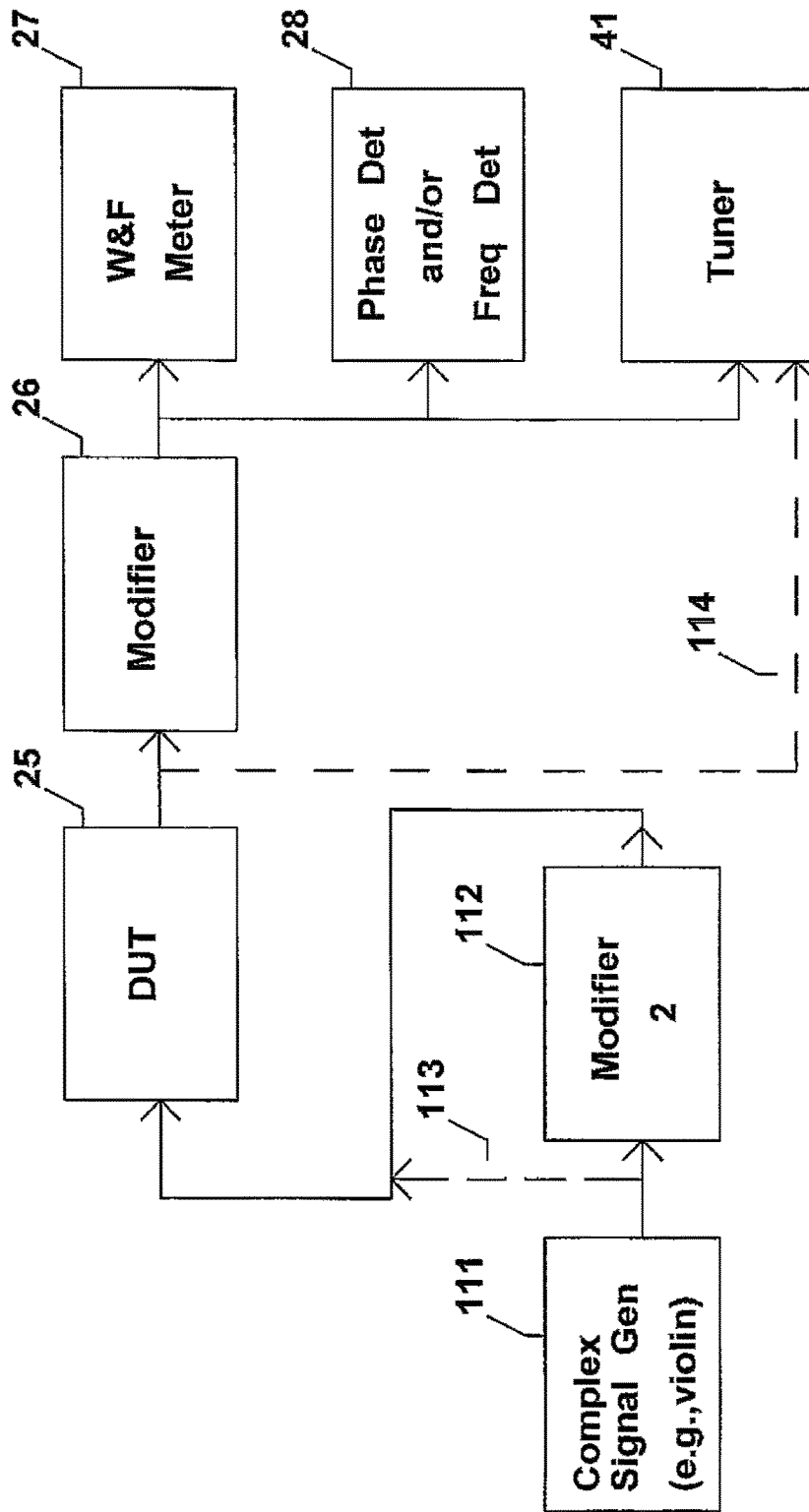

Figure 16

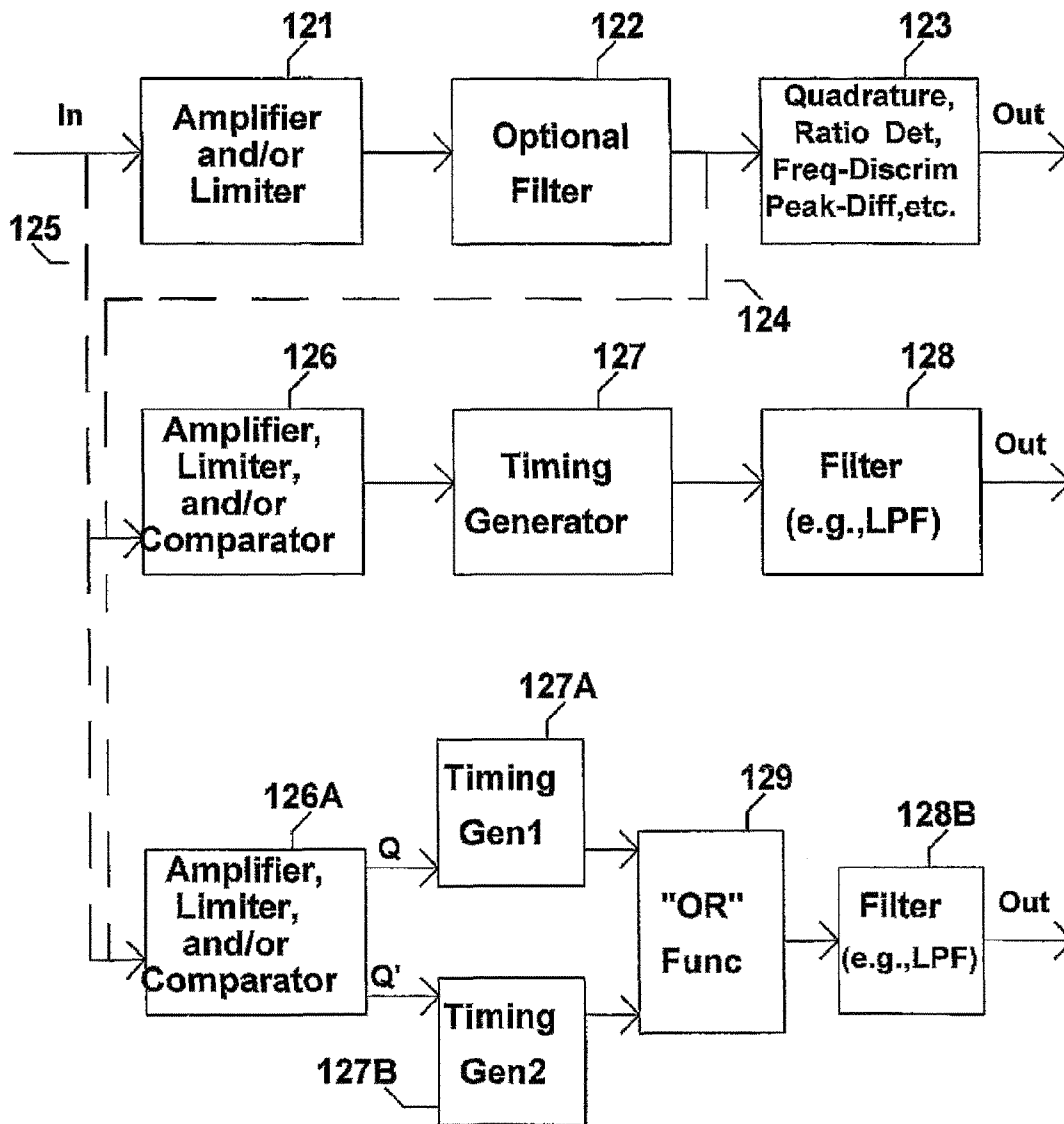

Figure 17

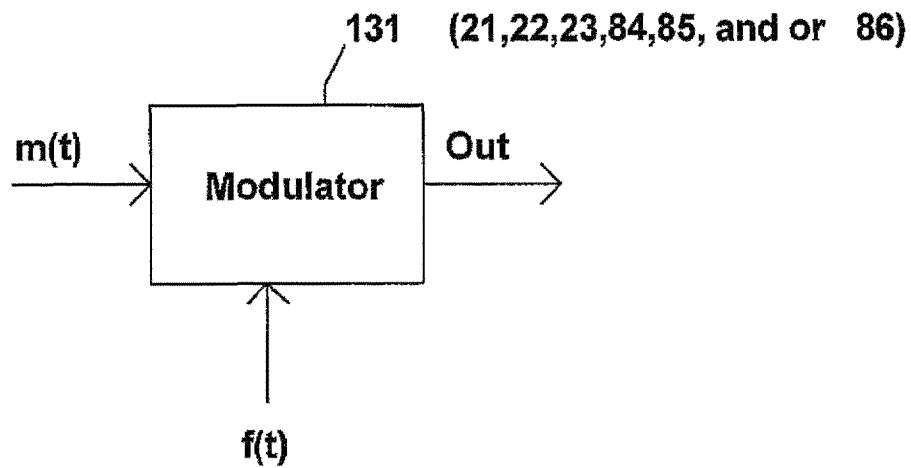

Figure 18A

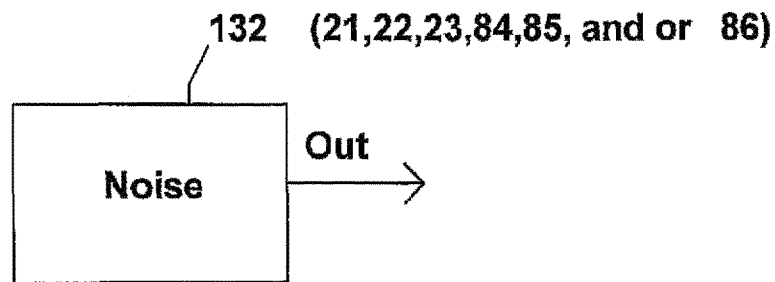

Figure 18B

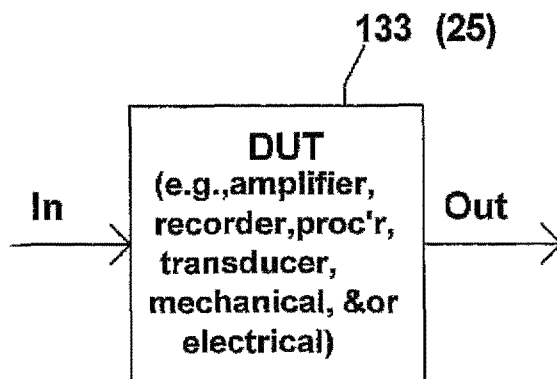

Figure 18C

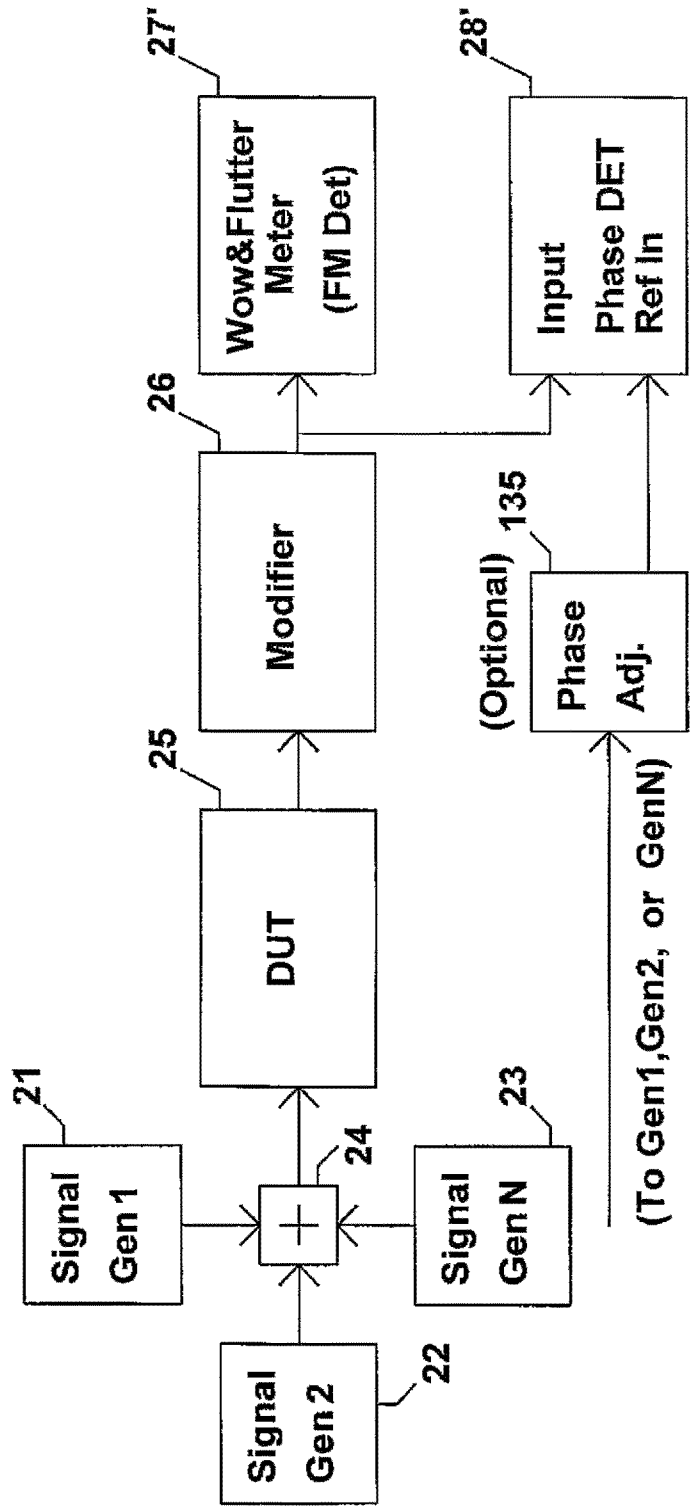

Figure 19

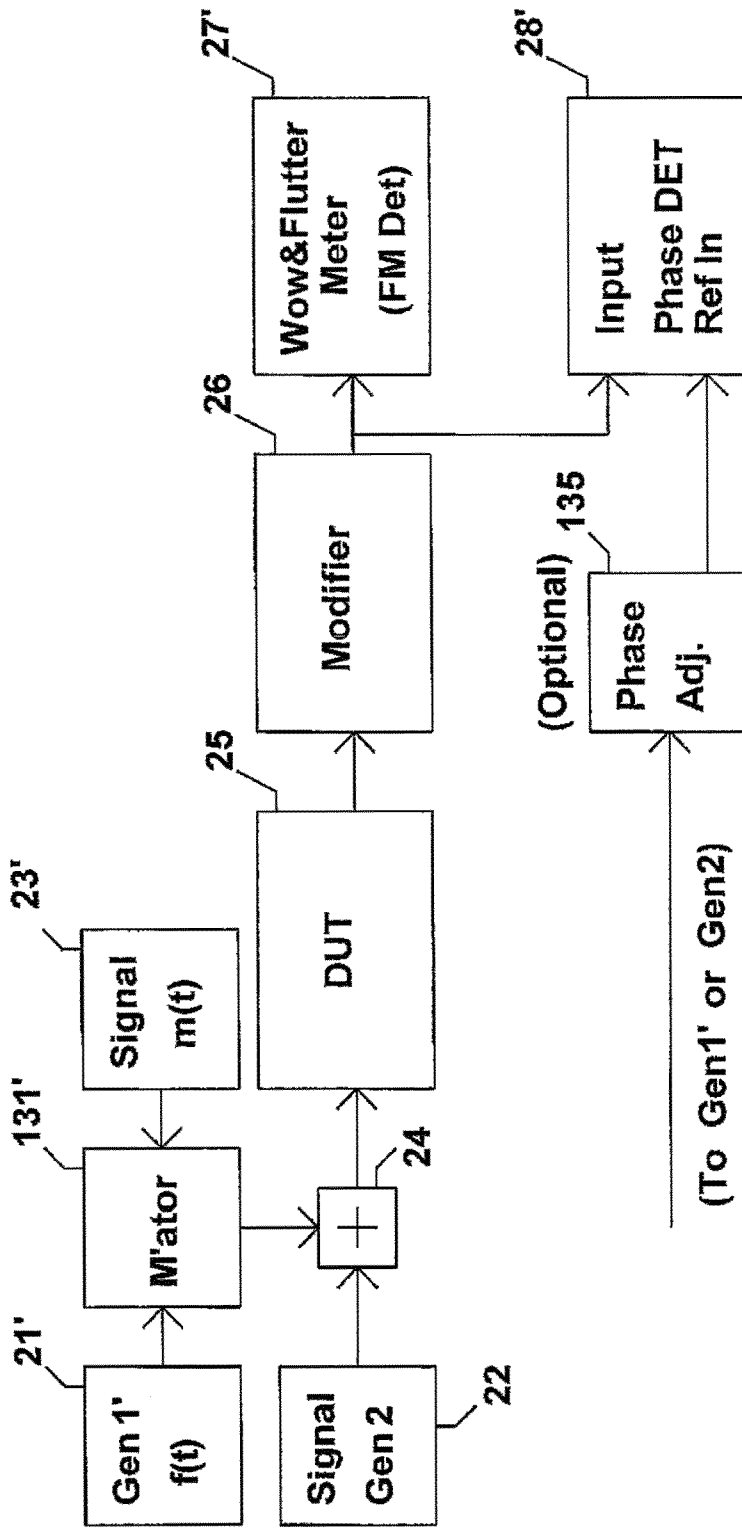

Figure 20

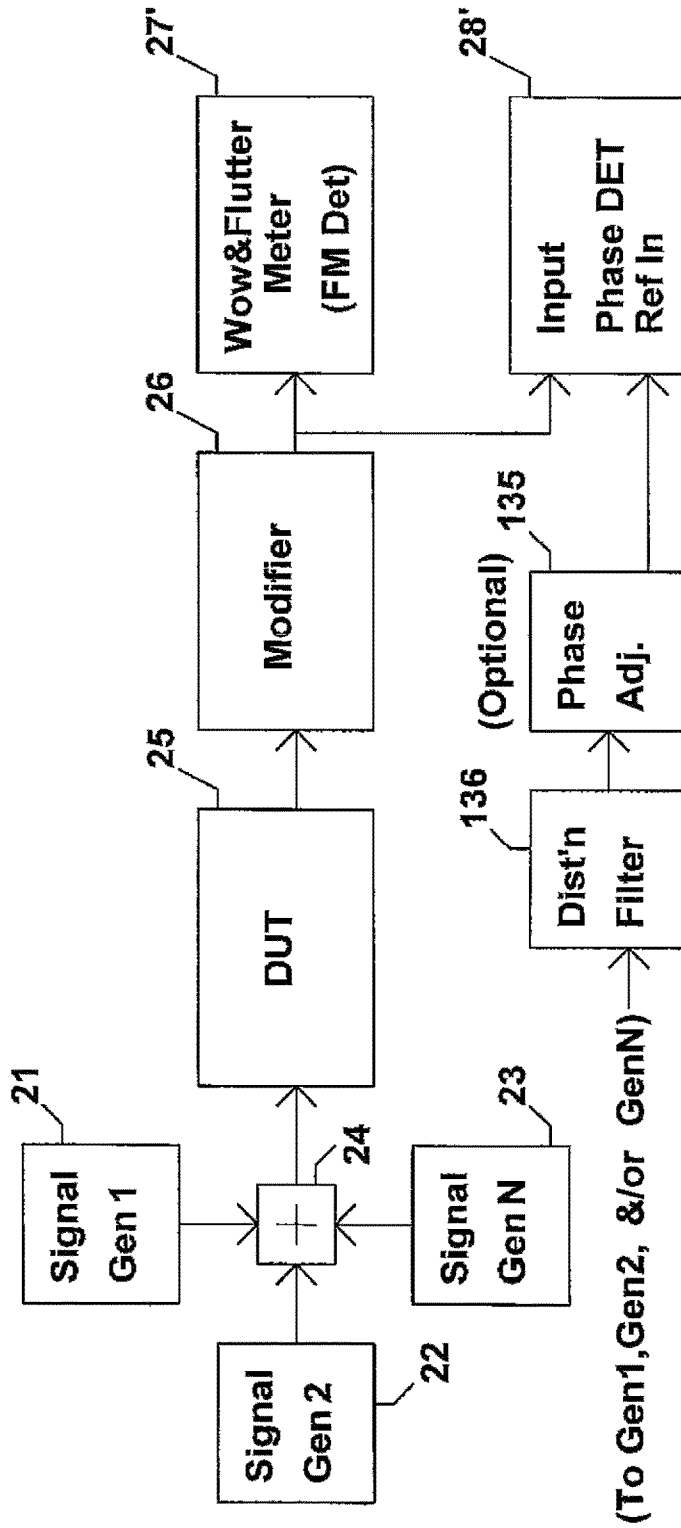

Figure 21

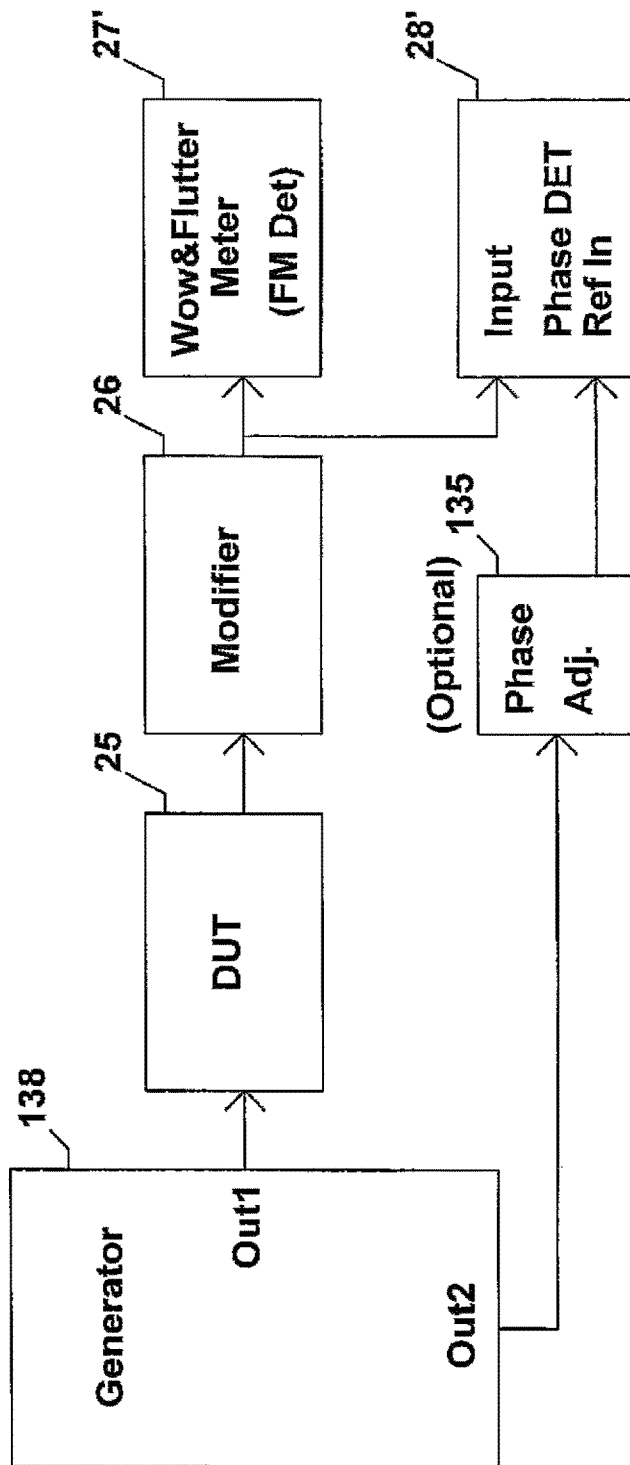

Figure 22

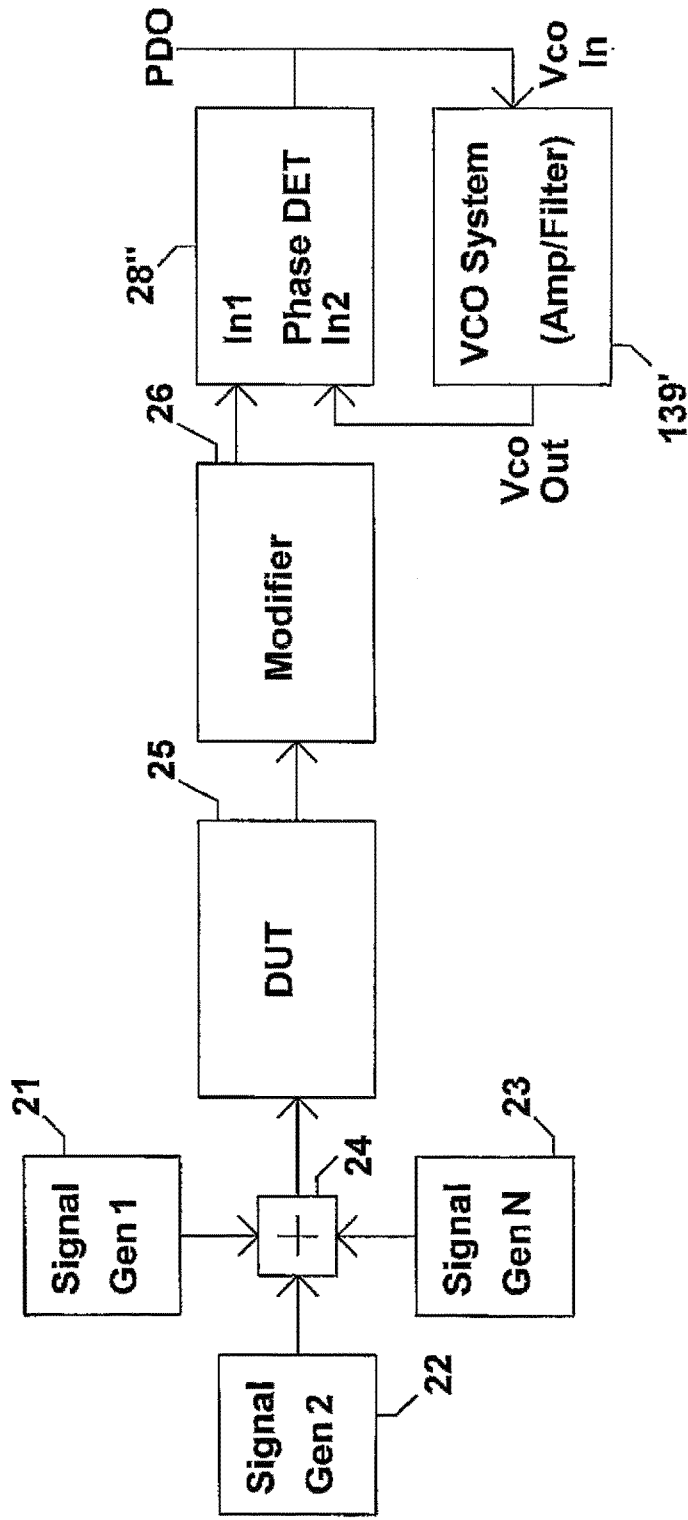

Figure 23

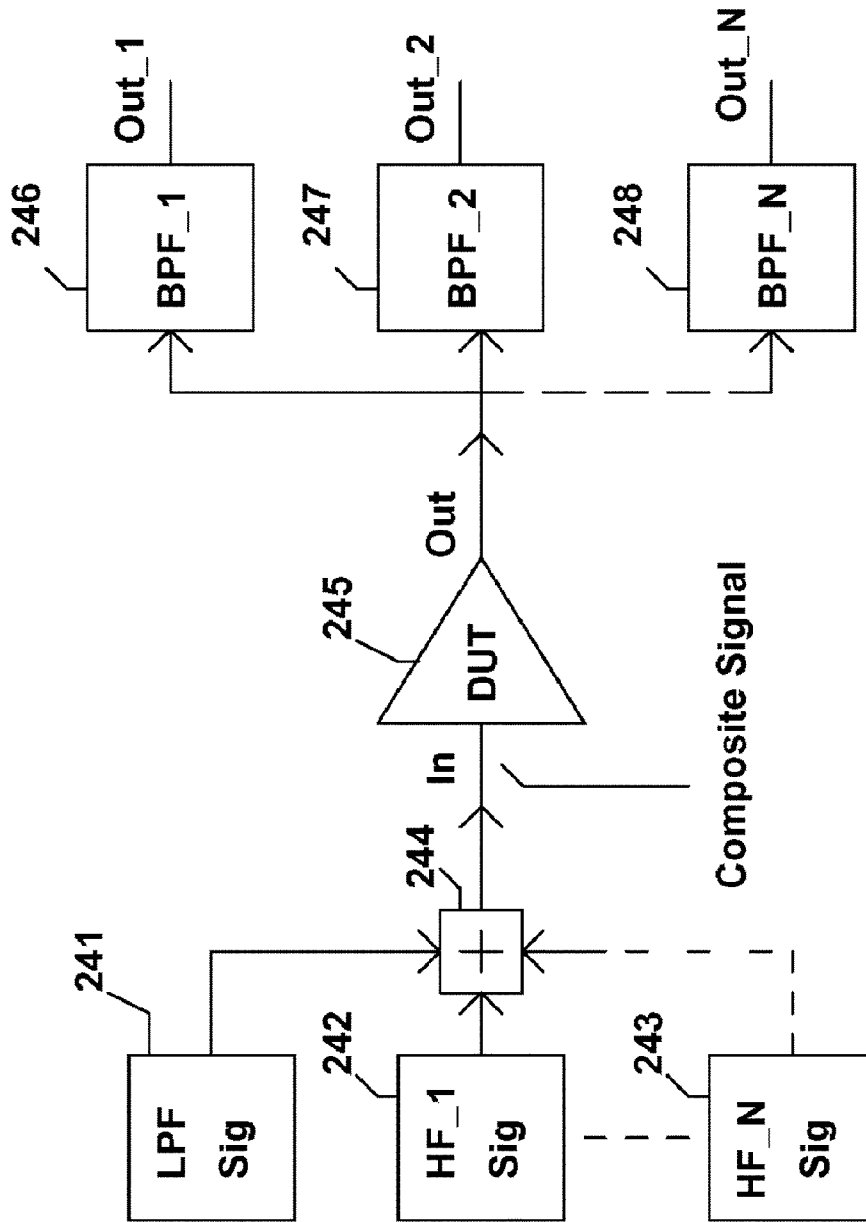

Figure 24

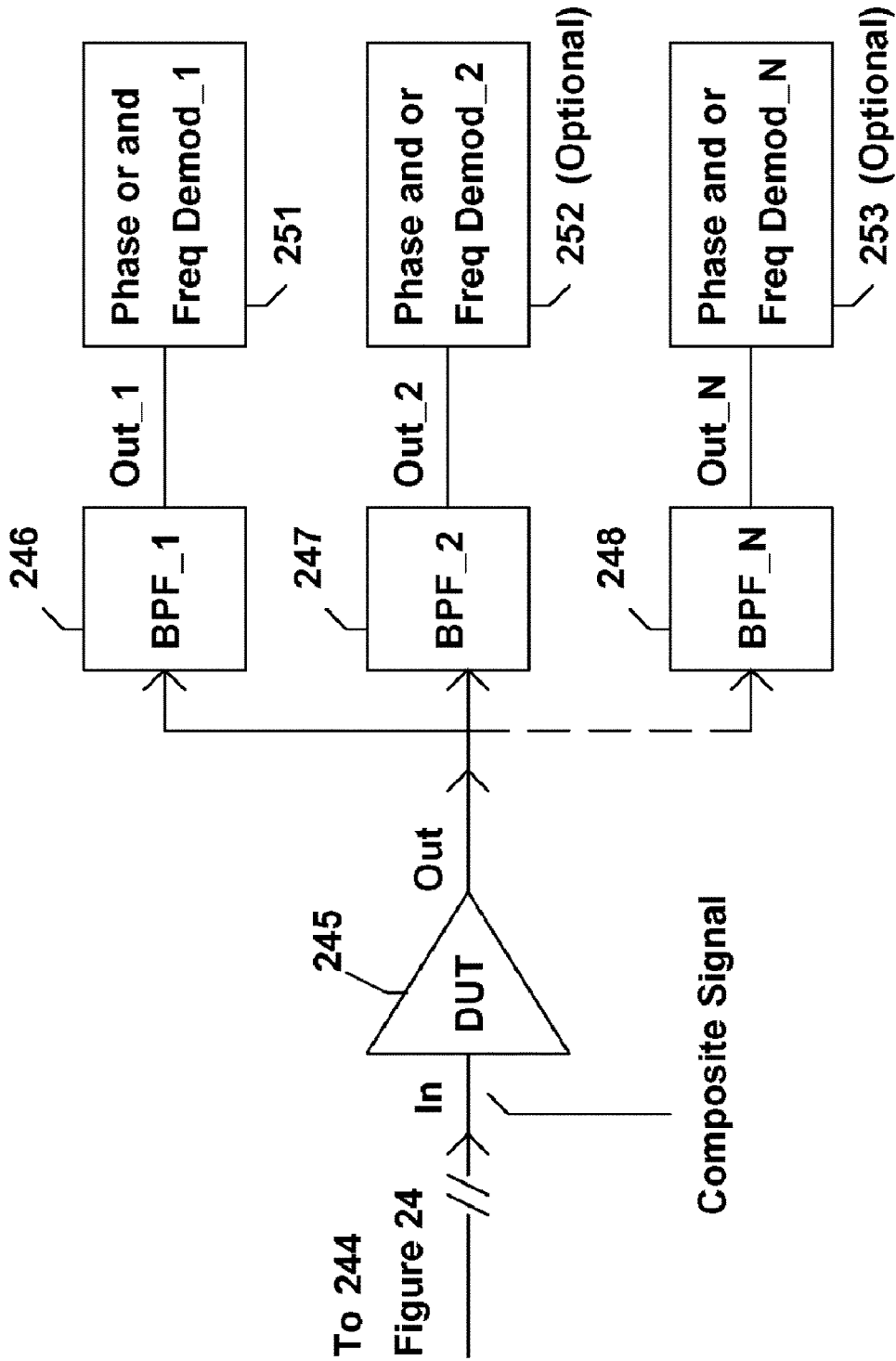
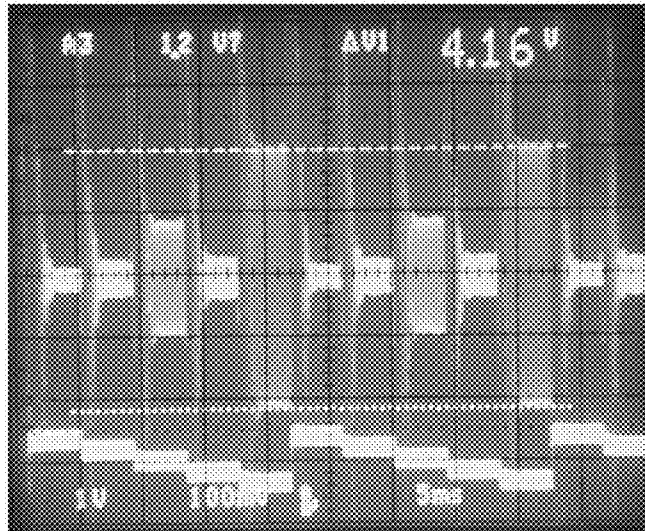

Figure 25



Top Trace: Second harmonic distortion displayed as a function of composite signal on below.

Bottom Trace: Composite signal

Figure 26

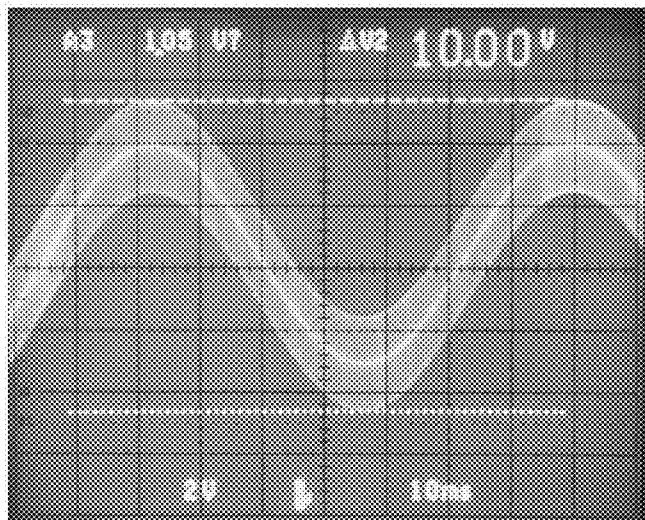

Composite signal example for intermodulation test signal.

Figure 27

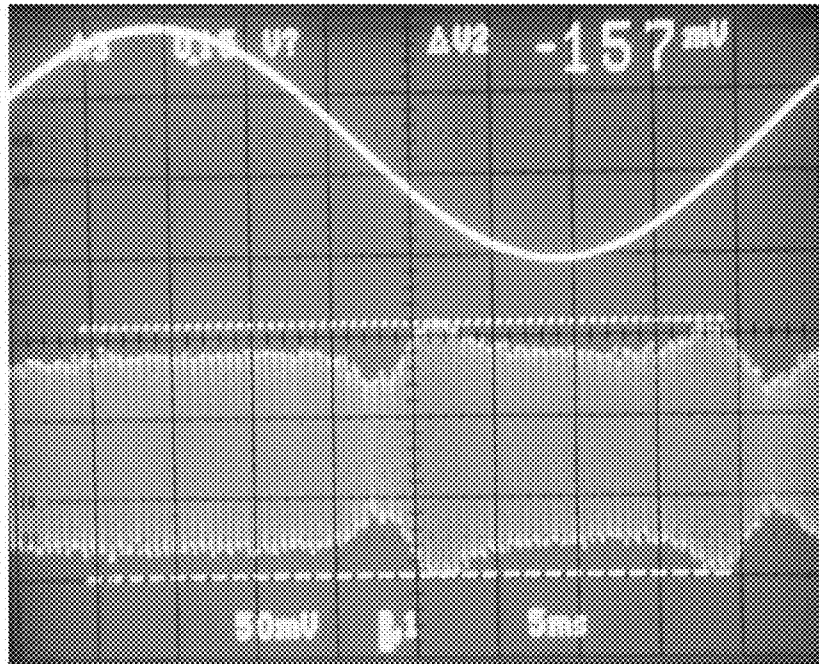

Figure 28

Top trace: Low frequency signal without the two or more higher frequency signals for intermodulation test.

Bottom trace: Second order intermodulation distortion as a function of the low frequency signal.

METHOD AND APPARATUS TO EVALUATE AUDIO EQUIPMENT VIA FILTER BANKS

This application is a continuation-in-part of U.S. application Ser. No. 13/556,556 filed Jul. 24, 2012, of U.S. application Ser. No. 12/875,563 filed Sep. 3, 2010, which is a continuation-in-part of U.S. application Ser. No. 12/707,425 filed Feb. 17, 2010, which is a continuation-in-part of U.S. application Ser. No. 12/456,752 filed Jun. 22, 2009, which is a continuation-in-part of U.S. application Ser. No. 11/508,700 filed Aug. 23, 2006, which claims benefit of U.S. provisional Ser. No. 60/721,027 filed Sep. 27, 2005, which are incorporated herein by reference.

BACKGROUND

This invention is related to the testing of audio equipment and, in particular, analog to digital converters (ADC), digital to analog converters (DAC), digital audio processors or recorders, audio amplifiers, and the like.

DESCRIPTION OF THE PRIOR ART

Presently, conventional harmonic and or intermodulation distortion tests are used to measure the performance of the audio equipment.

An intermodulation distortion test provides for two tones to be applied to the device, in which the amplitude of the sum and or difference of the tones may appear at the output of the device. In one case an AM detector (or amplitude measurement) is used for evaluating second order amplitudes of the difference and or sum of the frequency intermodulation products (e.g., F_1+F_2 and or F_1-F_2).

In another intermodulation distortion measurement, two tones are coupled to the device and the amplitudes of the third order intermodulation distortion products (e.g., $2F_1+F_2$, $2F_1-F_2$, $2F_2-F_1$, and or $2F_2+F_1$) are measured.

While these conventional tests are fine for many basic evaluations of the equipment, there still exist discrepancies between the sonic signature of amplifiers and equipment even with comparable distortion performance from the prior art testing methods. The conventional harmonic and intermodulation distortion measurements are done with a zero offset signal. Thus a new method of testing is required.

In audio testing, distortion is generally measured at a nominal (fixed) bias point for harmonic distortion. In the case of mechanical reproducing systems such as tape recorders and or phonograph players, conventional test methods are measuring harmonic and or intermodulation distortion. For measuring mechanical speed stability of the recorder or playback device, a single tone at about 3.00 KHz (or 3.15 KHz) is recorded and played back to assess Wow and Flutter (W & F).

It is well known in the past 40 years that video equipment uses a different set of performance tests. One of these tests is the differential phase measurement, which is based on a combined luma and chroma signal (e.g., modulated ramp or stairstep waveform and wherein the chroma signal is demodulated by a phase detector). This differential phase test allows an objective measurement of how a color signal of a particular color would change in hue under different brightness levels.

It is well known that program audio comprised of musical instruments and or voice may be a mixture of various low to middle frequency tones of a nominal (high) amplitude along with some smaller level of higher frequency components. Of course amplitude levels of low, middle, and higher frequencies occur in music.

It would be advantageous to provide different methods for addressing alternatives in testing audio equipment or other types of equipment.

SUMMARY

A testing method or apparatus utilizes a filter bank or filter banks to measure time varying or dynamic harmonic distortion or intermodulation distortion. With a stairstep signal and filter bank(s), Nth order harmonic and or intermodulation distortion is measured via the filter banks at different offsets provided by an arbitrary low frequency signal.

For example, an amplifier with crossover distortion will show increased harmonic and or intermodulation distortion near the zero crossing while providing less distortion in other portions of the transfer curve of the amplifier.

By using filter banks and an arbitrary low frequency signal combined with one or more tones, time varying harmonic and or intermodulation distortion can be measured. For example, a stairstep signal or multiple step signal of two or more levels is combined with a single or multiple tone that is coupled to a device under test will allow measurement of harmonic and or intermodulation distortion as a function of time and or dynamic offset voltage(s). Furthermore the harmonic and or intermodulation distortion signals from the filter banks may be coupled to phase detector or phase demodulator or frequency modulation detector (e.g., frequency to voltage converter) to measure differential phase, phase modulation, and or frequency modulation effect(s) from any of the distortion signal (e.g., via one or more filter banks).

One part of the invention is also concerned with measuring induced phase and or frequency modulation at the output (of any signal) from a device when two or more frequencies are coupled to the input of the device. This method of measuring induced phase and or frequency modulation may apply to various electronic equipment, amplifiers, processors, or the like over a wide range of frequencies.

A basic embodiment (of the invention) comprises measuring phase and or frequency modulation of a device under test (DUT) when two or more signals are coupled to the input of the DUT, wherein any phase or frequency modulation of any signal generated at the output of the DUT is measured. This basic embodiment may include measuring phase and or frequency modulation of any of the two or more input signals, harmonics of any input signals, and or any intermodulation components or products of the two or more input signals.

In an overview of some embodiments (of the invention), these embodiments are distinguished over conventional chroma video differential phase tests and standard Wow and Flutter measurement tests.

A distinguishing aspect of the invention over the prior art video chroma signal subcarrier differential phase and or gain measurement systems is that the differential gain and phase measurements have been used for measuring the color saturation and or hue distortions for a (composite) color television (TV) signal (such as an NTSC video signal). These color saturation and or hue distortions arise from a color subcarrier signal superimposed on a video luminance signal. The luminance signal is of a lower frequency, which biases the color subcarrier signal (e.g., 3.58 MHz NTSC color subcarrier frequency) to different brightness levels. If the video system is not perfect, the result will be that as the picture brightness changes, the color, which is supposed to display constant color saturation and hue, will shift in saturation and or hue. So prior art measurements for chroma differential gain and phase pertains to what is displayed on a TV monitor in terms of

distortions in color saturation and hue. The present invention does not pertain to color saturation or color hue distortions as displayed on a TV set.

A distinguishing aspect of the invention over prior art Wow and Flutter measurement methods is that prior art Wow and Flutter measurement systems are not used in amplifier or electronic systems. Instead, the Wow and Flutter measurements are to reveal speed irregularities in mechanical record and or playback systems such as tape recorders and phonograph turntables. Until the disclosure of this invention, non-mechanical systems such as amplifiers or audio processors have not been tested with a Wow and Flutter meter. Should a standard Wow and Flutter test is made on a non mechanical apparatus such as an amplifier, the Wow and Flutter will measure zero percent. That is, the standard single 3000 Hz tone from the Wow and Flutter test source into an amplifier will produce at the amplifier's output a 3000 Hz signal without Wow and Flutter and without frequency variations.

One basic discovery by the inventor involves the unexpected measurement of Wow and Flutter in amplifiers with a new testing method (e.g., a new test method that involves two or more frequencies instead of the one single frequency for standard Wow and Flutter measurement). Because electronic (non-mechanical) amplifiers are not known to behave like (mechanical) recorders or play back devices of recorded signals, it is then a unique process to measure Wow and Flutter via an amplifier circuit.

The new test method measures small variations of frequency or phase response differences as a function of output or input swing. These phase or frequency variations show up as Wow and Flutter when a dynamic biasing signal (which may include close to DC in frequency) is used, hence the need for more than one frequency for a new test in accordance with the invention.

In a mechanical recorder or playback machine, a speed variation exists upon recording or playback of an electronic signal. This mechanical player or recorder will exhibit an amount of speed variation, which translates to a frequency variation of an electronic signal. Such a frequency variation can lead to the characteristic for example of a "sour" tone for reproducing a sustained piano note.

The standard measurement technique is to supply a single frequency tone to the mechanical device for record and playback or for playback via a prerecorded media (e.g., prerecorded tape or disc). Upon playback of the mechanical device, the single frequency tone is measured for frequency variation via a Wow and Flutter meter (e.g., Leader model LFM-39A).

At least one embodiment (of the invention) is therefore distinguished over the standard measurement for Wow and Flutter. One reason is that at least another signal is added or involved, and or a modifier circuit or method is used to allow (e.g., reduce interference from the other signal or signals) for measuring the frequency variation of the signal involved.

Another reason that there is distinction is that Wow and Flutter meters are used for measuring speed variation of mechanical systems, not non mechanical apparatus such as electronic amplifiers or electronic processors.

Thus, one object (of the invention) is to measure frequency (or phase) variation of a signal caused by another signal.

In one embodiment, measurement is done such that a lower frequency signal causes a frequency (or phase) modulation on at least one higher frequency signal (AKA Quan effect #1 for frequency modulation of a higher frequency signal induced by a lower frequency signal). Frequency or phase variation is then measured for any of the higher frequency signal(s),

which may include its distortion components or products (e.g., from an amplifier or processor).

Alternatively, in another embodiment, measurement is done such that a higher frequency signal causes a frequency (or phase) modulation on one or more lower frequency signal (AKA Quan effect #2 for frequency modulation on a lower frequency signal induced by a higher frequency signal, and AKA Quan effect #3 for phase modulation on a lower frequency signal induced by a higher frequency signal). Frequency or phase variation is then measured for any of the lower frequency signal(s), which may include its distortion components or products (e.g., from an amplifier or processor).

For example, in one embodiment, a larger amplitude "low" frequency signal below 400 Hz is added to a 3 KHz signal from the Wow and Flutter meter (e.g., Leader model LFM-39A). The 3 KHz signal is adjusted to have a lower amplitude that that of the lower frequency signal (e.g., 100 Hz, 150 Hz, or 300 Hz, or any other frequency, or >300 Hz). The two signals are then combined and fed to the input of an amplifier or amplifier system, which may be named DUT (Device Under Test). The output of the amplifier or DUT is fed to a filter or modifier, which removes, modifies, and or attenuates the lower frequency signal. The output of the filter (or modifier) is then fed to a Wow and Flutter meter or a detector (e.g., phase detector and or FM detector).

For this example, the low frequency signal was 100 Hz (sine wave) and the higher frequency signal was 3000 Hz (sine wave). A simple (microphone) two-transistor feedback amplifier was set for a gain of 91 and had a -3 dB frequency response at 17 KHz. About 3.9 volts peak to peak of the example 100 Hz signal and about 100 millivolts to 160 millivolts peak to peak of the example 3000 Hz signal was measured at the output of the amplifier. Then a (e.g., 3000 Hz) bandpass, or high pass filter, or modifying circuit) filter/modifier essentially removed the 100 Hz signal and passed the 3000 Hz signal from the amplifier's output to the Wow and Flutter meter, which read 0.15% Wow and Flutter (W&F). Considering the amplifier is not mechanical system, this new test showed an "unexpected" result that amplifiers exhibit Wow and Flutter during the presence of a multiple signal input.

In comparison to a very high quality cassette audio recorder such as the Pioneer CT-F1000 (cost of \$600 from "High Fidelity Test Reports 1979" issue), the Wow and Flutter measured 0.08%. Note that in this cassette deck test, the Wow and Flutter meter only sends out either a 3000 Hz or a 3150 Hz test signal (but not both frequencies) for the cassette recorder to record and playback the test signal. (There is no other signal, other than the single tone involved for this standard W&F measurement of the cassette audio recorder).

Thus, the invention or an embodiment is considered novel over the prior art in that multiple signals or tones are used. These multiple signals or tones are sent to a DUT (device under test). The DUT is coupled to a modifier, which allows a Wow and Flutter meter or phase detector or FM detector to measure at least one particular test tone(s) essentially without interference from the other tones (e.g., lower frequency tones or any of its harmonics). Thus, from the example test with the two transistor amplifier mentioned above, this amplifier yielded almost twice the Wow and Flutter of a (mechanically driven) cassette tape recorder (e.g., 0.15% for amplifier under new testing method versus 0.08% for the Pioneer CT-F1000 cassette audio recorder).

Other experiments with amplifiers that exhibit cross over distortion yielded similar results of the two-transistor amplifier experiment mentioned above. Cross over distortion in an

amplifier causes a drop in bandwidth in the “dead zone”, so as a dynamic biasing signal causes a higher frequency signal to go in and out of the dead zone, the frequency response changes in time.

And (in general) an increase in frequency for the dynamic biasing signal applied, the more change in phase occurs in time, which leads to a greater/increased FM effect or greater/increased frequency deviation (e.g., of a higher frequency signal). In some cases, an amplifier with cross over distortion yielded even more Wow and Flutter such as 0.175% (in this example of a new way to measure Wow and Flutter or to measure a frequency modulation effect of one signal induced by another signal). And if the lower frequency signal (e.g., dynamic biasing signal) is raised from 100 Hz to a higher frequency such as 140 Hz or higher, Wow and Flutter measurements (via an embodiment of the invention) increase to about 0.36% or higher.

Because there is a phase shift change in the (higher frequency) signal as a function of where the output is “biased” to, when the low frequency signal is increased in amplitude and or frequency, a greater change in phase shift over time of the higher frequency signal will occur. And the greater phase shift per time translates to a greater shift (e.g., deviation) in frequency of the higher frequency signal (e.g., more frequency modulation). For example, in another embodiment of the invention, a (higher amplitude) 2000 Hz signal was combined with a lower amplitude 15 KHz signal into the two transistor feedback amplifier example. The output of the two transistor feedback amplifier had comparable amplitude levels as the previous example with 100 Hz and 3000 Hz signals. And the output of this example amplifier was coupled to a high pass filter (to remove the 2 KHz signal while passing the 15 KHz signal), which was then coupled to a frequency to voltage converter. The output of the frequency to voltage converter revealed a frequency shift or deviation of 1.5% for the 15 KHz signal (caused by the 2000 Hz signal) from the output of the two transistor feedback amplifier example.

It should be noted that cascading amplifiers for making an amplifier system, (e.g., preamplifier coupled to a tone control amplifier, which then couples to a power amplifier) will generally cause an increase in phase or frequency modulation effect (e.g., in total). The phase and or frequency modulation effect of each amplifier in a chain may be additive or cumulative in some manner. Depending on the phase versus bias voltage effect on amplifiers, in some cases the cascading of certain amplifiers may reduce the phase and or frequency modulation.

In general but not limited to, the new test of the present invention comprises providing 2 or more frequencies such as a lower frequency signal to a higher frequency signal (to yield a complex or composite signal) and coupling this complex signal to the amplifier’s or device’s (e.g., a device may be electrical, mechanical, magnetic, optical, electromechanical, and or a transducer) input. At the output of the amplifier (or device) under test, the lower frequency signal (which may include any of its harmonics) is modified (e.g., reduced in amplitude or removed), and the higher frequency component is coupled to a detection circuit or system (e.g., computational system, Wow and Flutter meter, FM detector, phase detector, and or frequency to current or voltage converter). The lower frequency signal will cause a dynamic bias upon the amplifier or device under test, and thus the amplifier or device can exhibit a different frequency response (or phase change/delay) for each different bias point as defined by the test.

The difference in the higher frequency response (e.g., when biased by a lower frequency signal) yields a difference in phase response according to various bias points via the

lower frequency signal. By measuring the phase changes or shifts or angles of the higher frequency signal as a function of bias points (caused by the lower frequency signal), the output phase modulation of the higher frequency signal can then be measured or computed. By providing a slope or derivative function of the phase modulation, a frequency modulation effect can be measured or computed.

Of course, the output of the modifying circuit, which contains the phase (or frequency) modulated signal may be coupled directly to a phase detector or frequency modulation detector. Examples of phase detectors may include mixers or multiplying circuits, balanced detectors, phase lock loop circuits and or the like. And examples of frequency modulation detectors may include frequency discriminators (e.g., Foster Seeley), ratio detectors, quadrature detectors, peak differential detectors, phase detectors, phase shifting circuits, phase lock loop circuits, pulse counting circuits, frequency to signal converters, slope detectors, and or the like.

In an another embodiment (of the invention), a bias or operating voltage of an audio equipment is varied and a (e.g., nominally higher frequency) signal is added. Because many audio equipment such as digital systems or amplifiers may have different nonlinearities at various operating points such as quantizing error or crossover distortion, a fuller picture of the equipment is evaluated via a variable bias signal plus a (high frequency) signal.

For example, an embodiment (of the invention) may include biasing (e.g., providing a variable/dynamic offset voltage or current) an amplifier, device, and or a digital system with a voltage to span an output voltage range of the device while measuring harmonic or intermodulation distortion or phase or frequency (or phase) response at the various operating points.

In a further example, an embodiment provides one or more frequency signals above 10 KHz (such as a signal at 18 KHz and a signal at 20 KHz), and then provides a larger amplitude (lower frequency) signal in the range between 20 Hz and 10 KHz (such as a signal whose frequency is any between 20 Hz and 5 KHz; 300 Hz for example).

The lower frequency signal plus one or more of the higher frequency signals are then combined and coupled to the (DUT) (e.g., amplifier, ADC, and or DAC). The output of the DUT is then coupled to a modifier, which affects, modifies or removes the lower frequency signals (e.g., FL) and or the lower frequency signal’s harmonics. The output of the modifier then is coupled to at least one detector such as a phase detector or an FM detector, which can measure the phase and or frequency modulation effect on the one or more higher frequency signals.

In the case of more than one higher frequency signal, the detector may include an apparatus or method to remove substantially all but one of the higher frequency signals, which may include intermodulation distortion signal(s). For example, to reduce interference from one (high frequency) signal to the other in terms of detection or demodulation (e.g., of phase modulation and or frequency modulation). Thus, in this example, the detector will measure phase and or frequency modulation effects on the 18 KHz and or 20 KHz signals caused by the 300 Hz signal. The detector (via a modifier) may be used to measure the phase and frequency modulation effects on one or more intermodulation distortion frequencies such as 2nd, 3rd, and or higher order intermodulation components (or harmonics).

For example, the detector may measure phase and or frequency modulation effects for second order intermodulation component. In this example, the sum and difference frequency distortion signals (e.g., 18 KHz+20 KHz=38 KHz,

and or 20 KHz–18 KHz=2 KHz). And third order intermodulation distortion components (e.g., 2FH1–/+FH2, 2FH2–/+FH1) may be measured for phase and or frequency modulation effects. In this third order intermodulation example, 2×20 KHz–18 KHz=22 KHz, and 2×18 KHz–20 KHz=16 KHz and or the third order sum components. Also the phase and or frequency modulation effects of any of the harmonics of any of the higher frequency signals may also be measured. In this example, 2×20 KHz=40 KHz and or 2×18 KHz=36 KHz.

Of course other frequencies may be used for FH, such as making FH>FL (e.g., FL<2 KHz, FH>5 KHz).

For example, the lower frequency signal (FL) may be <2 KHz and the higher frequency components (FH) may be a signal or multiple signals at 9 KHz and or 10 KHz. In this example the second harmonics of the 9 KHz and or 10 KHz FH signals can be measured for phase and or frequency modulation effect(s).

Yet another embodiment may include a low frequency signal with a smaller amplitude higher frequency signal to test a dynamic change in frequency response, gain, and or phase. The change in phase with a time varying signal will then produce an FM effect.

Still another embodiment may include using a multiple frequency signal to dynamically induce a time varying phase (or frequency) distortion for the device that has differential phase distortion. The device's output is then measured with an FM (or PM) detector or discriminator in order to find a (frequency or dynamic phase) shift in at least one of the frequencies used in the test signal (or at least one of the distortion products from the DUT). For example, the complex or composite signal may include one or more lower frequency signals and more than one higher frequency signal. Another method of measuring dynamic phase (modulation) and or frequency (modulation) effects after the modifier, may reveal that the modulation effects may or may not track with the (various) higher frequency components. The modifier removes/attenuates the lower frequency signals and may remove or attenuate any harmonics of the lower frequency signals.

Another embodiment may include a high frequency reference signal added prior to or after a combination of a low frequency and higher frequency signal. The duration of the high frequency reference signal, which may include for example a synchronizing signal would be shorter than that of the low frequency and high frequency signal. This is similar to a TV signal, but is used to test for non-TV applications such as audio and or RF systems. In some cases, the audio device under test may output a signal not synchronous to the input signal (e.g., the output of a digital processor may not have exactly the same frequency at its output as its input signal's frequency). In this embodiment at least one synchronizing signal is needed at the output to provide a testing method or apparatus for generating a reference phase and or frequency, which is similar to a TV color burst signal or a data clock reference signal.

In an alternative embodiment (of the invention) for non-standard testing of audio (or other) equipment, one or more modulated waveforms may be coupled to the device. One such waveform may be an amplitude modulated waveform, which may be combined with an offset signal such as a ramp or generated waveform or DC offset that may be varied. Then the analysis of a modulated waveform's sidebands or carrier(s), in terms of any extra sidebands, or phase shifts in sidebands or carrier(s), or changes in frequency of any sidebands or carrier(s), is done (e.g., at the output of the device

under test). A phase or frequency detector may also be used in analyzing the device under test in terms of phase or frequency errors.

Another modulated waveform (for another embodiment) may include a frequency or phase modulated signal that is added to an offset signal such as previously described. It also is possible to provide any combination of modulations on a signal for a non-standard test of audio equipment.

In any of the embodiments or examples described, the waveform may be set to a small amplitude as an offset is being varied for testing a digital system (e.g., analog to digital converter, or combined testing of analog to digital converter and or digital to analog converter) and or for testing an analog system. For example, quantizing errors can reveal shifts in frequency or phase, or sideband distortion.

Computational analysis of the sidebands generated by the higher frequency signal(s) may be found such that generating a Bessel function map that can then yield the deviation of the higher frequency's FM (or PM) effect. Some of the Bessel function sidebands may be out of phase, and a method to find/identify the phase can be done by adding an AM signal wherein the modulating signal includes fundamental and harmonics of a known phase. The AM signal is combined or added with the higher frequency signal (that may exhibit frequency modulation) and sidebands are assessed whether there was an increase or decrease in sideband amplitude. For example, those sidebands that are reduced in level denote an out of phase sideband. Once a sufficient number of or all sidebands are measured in amplitude and phase, the Bessel function can be determined. Thus the modulation index is calculated. With the modulation index calculated, the frequency or phase deviation of the higher frequency component is calculated or found.

Although the embodiments or examples described are generally for audio equipment testing, any of the test embodiments described herein may be used for testing of non-audio equipment, e.g., such as an RF amplifier/device or a part of a communication system or a video device.

A summary of various of the embodiments (in which any method may be an apparatus) of the invention is stated below:

A new testing method and apparatus comprises the application of multiple frequencies to a device under test for measuring newly discovered frequency modulation effects. This new testing method may be applied to audio and or radio frequency devices.

An embodiment may include a lower frequency signal with a smaller amplitude higher frequency signal to test a dynamic change in frequency response, gain, and or phase. This dynamic test can reveal frequency modulation effects.

Another embodiment may include using a multiple frequency signal to dynamically induce a time varying phase distortion for a device that has differential phase distortion. The device's output is then measured with an FM detector or discriminator in order to measure a shift in one of the frequencies used in the test signal or to measure frequency modulation effects of any signals (e.g., any test signals and or distortion products) output from the device.

For example, an embodiment (of the invention) may include biasing an amplifier or a digital system with a voltage to span the output voltage range of the device while measuring harmonic or intermodulation distortion or phase or frequency response at the various operating points.

Below is a further summary of various embodiments (of the invention):

Method of measuring frequency modulation effects of an electronic device, wherein the device has an input and an output, comprising, coupling two or more frequency signals

into the input, and providing an FM detector at the output of the device, to measure a frequency modulation effect or frequency shift for one or more frequency signals at the output of the device.

Method of measuring Wow and Flutter effects on an electronic device comprising, applying multiple frequencies to the input of the device, coupling the output of the device to the input of a modifier circuit, and coupling a Wow and Flutter meter to the output of the modifier.

The invention or an embodiment includes a method wherein the modifier circuit reduces amplitude of a frequency or removes one or more selected frequencies, and also a method of measuring induced phase or frequency modulation in a signal of multiple frequencies, or more than one signals of different frequencies.

The invention or an embodiment further includes a method of applying a signal or signals to the input of a device, and measuring via a phase and or frequency modulation detector at the output of the device at least one phase and or frequency modulation effect on any selected signal frequency from the output of the device.

The invention or an embodiment also includes:

A method wherein the selected frequency from the output of the device may include any fundamental, harmonic, and or intermodulation frequency component.

A method wherein an amplitude detector measures amplitude variations of any of the phase and or frequency modulated signal frequencies.

A method wherein the derivative of the phase detector is taken to provide a frequency modulation measurement, and or wherein an integrated function of the frequency modulation detector provides a phase modulation measurement.

A method wherein one of the signals is a dynamic biasing signal, wherein the dynamic biasing signal provides a dynamic offset output voltage or current, and

A method of measuring dynamic distortion of an electronic device, wherein a dynamic offset voltage is combined with a test signal comprising, applying the combined dynamic offset voltage and test signal to the input of the device, and measuring the dynamic distortion for at least one offset voltage.

The invention or an embodiment (also) includes a method of providing an audio and or radio frequency test signal, comprising, adding and or inserting a lower frequency signal, one or more reference higher frequency signal packets of one or more frequencies, and one or more signals of higher frequencies to provide the test signal, and also a method wherein an optional unipolar or bipolar synchronizing signal is added or inserted.

The invention or an embodiment includes a method of measuring frequency modulation effects of a device under test, wherein a test signal is input to the device, and wherein the test signal includes a lower frequency signal combined with a higher frequency signal, comprising, coupling a frequency to voltage converter or FM detector to the output of the device, and measuring the higher frequency signal for at least one frequency modulation effect.

In addition the invention or an embodiment includes a method wherein the test signal includes an optional synchronizing signal, and a method wherein the measured frequency modulation effect is displayed.

Also included is a method of measuring a phase and or frequency modulation effect of a device, wherein the input of the device is coupled to at least one signal of two or more frequencies, wherein the at least one signal induces a phase or frequency modulation effect on the device, whereby the output of the device is coupled to a tunable filter which tunes to a selected frequency of a signal from the output of the device,

and wherein a phase detector and or a frequency modulation detector measures the phase and or frequency modulation effect of the device.

The invention or an embodiment includes a method of a measuring a phase and or a frequency modulation effect of a device, comprising coupling multiple frequencies to the input of the device, wherein the output of the device generates a frequency modulation effect on one or more of its output signal frequencies, whereby the output of the device is coupled to a phase detector, FM detector, and or frequency to voltage converter for measuring at least one phase modulation and or frequency modulation effect of any signal frequency from the output of the device.

Further the invention or an embodiment includes a method wherein a modifier is couple to the output of the device, and whereby the modifier removes or reduces the amplitude of at least one selected signal frequency, wherein the output of the modifier is coupled to a Wow and Flutter meter.

The invention or an embodiment includes a method of measuring at least one phase modulation and or frequency modulation effect of an audio device that has an input and an output, comprising, coupling one or more signals including two or more frequencies to the input of the audio device, coupling a phase detector, FM detector, and or frequency to voltage converter to the output of the audio device to measure phase modulation and or frequency modulation at any signal frequency from the output of the device.

The invention or an embodiment further includes:

A method wherein a modifier or filter is placed between the output of the audio device and the input of the phase detector, FM detector, and or frequency to voltage converter.

A method wherein the modifier removes or reduces in amplitude one or more signals from the output of the audio device.

A method wherein the modifier is coupled to a Wow and Flutter meter, and

A method wherein the Wow and Flutter meter is modified for wider bandwidth.

BRIEF DESCRIPTION OF THE DRAWINGS

FIGS. 1A and 1B show a prior art configuration in testing frequency deviation effects via a Wow and Flutter meter.

FIG. 1C shows a prior art method of using a two-tone test for measuring the amplitude of intermodulation distortion.

FIG. 2 shows a prior art method to measure phase distortion in a color video signal.

FIG. 3 shows an embodiment example.

FIGS. 4A through 4F show various modification methods or circuits of the invention or of an embodiment.

FIG. 5 shows another example embodiment.

FIG. 6 shows yet another example embodiment. For example, an FM, PM, and or AM receiver will tune into various signal components from the DUT's output, which may be used to measure, capture, and or store frequency, phase, and or amplitude modulated deviations.

FIG. 7A shows an example of an input signal spectrum applied to a DUT (device under test).

FIG. 7B shows the output of the DUT used in FIG. 7A, which may include at least one phase or frequency modulated signal.

FIG. 8A shows another example of an input signal spectrum applied to a DUT.

FIG. 8B shows the output of DUT used in FIG. 8A, which may include at least one phase or frequency modulated signal. This modulated signal may include a signal that is any one of many distortion products, for example.

11

FIG. 9A shows another example of an input signal applied to a DUT.

FIG. 9B shows the output of a DUT which include at least one signal component that can be measure for phase, frequency, and or amplitude modulation effect.

FIG. 10 shows a method to generate amplitudes of fundamental and or distortion products, which for example can be used to reduce various signals after the DUT's output.

FIG. 11 shows a method to reduce the interference of at least one interfering frequency such that measurements may be made in terms of phase and or frequency modulation of one or more signals.

FIG. 12 shows an example test waveform that may include at least one reference signal.

FIG. 13 shows an example embodiment of a method and or apparatus to generate a test waveform.

FIG. 14 shows an example embodiment that can measure phase and or frequency modulation

FIG. 15 shows an example embodiment that can measure frequency or phase modulation.

FIG. 16 shows an example of using a complex signal to test for phase and or frequency modulation of one or more selected signals.

FIG. 17 shows one or more ways to detect or demodulate a signal that has a frequency modulation effect.

FIG. 18A shows a modulator, which may provide a modulated signal source. FIG. 18B shows a noise generator, which may provide a noise signal source. And FIG. 18C shows one or more examples of the DUT.

FIGS. 19, 20, 21, and 22 show examples for measuring differential phase by deriving a signal from one or more input source and coupling to a phase detector.

FIG. 23 shows an example of an improvement to measure differential phase.

FIG. 24 shows an example of using filter banks to measure time varying distortion.

FIG. 25 shows an example of using filter banks including a phase and or frequency modulation detector or demodulator to further measure phase and or frequency modulation effect(s) from distortion signal(s).

FIG. 26 shows an example of the time varying harmonic distortion or intermodulation distortion when a composite waveform comprised of a staircase signal and higher frequency is utilized.

FIG. 27 shows an example test signal for measuring time varying intermodulation distortion, or for measuring time varying harmonic distortion.

FIG. 28 shows an example of measured time varying intermodulation distortion as a function of a low frequency signal.

DETAILED DESCRIPTION

FIG. 1A shows a standard prior art method of performing a Wow and Flutter test. A test tone signal, 2, of 3000 Hz (or 3150 Hz) tone is coupled to a recorder, 3. This recorder may be a tape recorder or a disc recorder.

FIG. 1B shows further that the recorded test tone is then played back via 3 and coupled to a Wow and Flutter meter, 4, for measurement of frequency deviations of the single tone (for a prior art standard method of measuring Wow and Flutter). These frequency deviations of the test tone are for example a result of the non-perfect speed or velocity in which the mechanical recorder exhibits upon recording and or playback.

One object (of the invention) is to assess phase or frequency modulation from an audio system or amplifier caused by the two or more input signals. Therefore, FIG. 1B, which

12

shows standard (prior art) testing for Wow and Flutter, does not apply (for example, to a multiple signal method of an embodiment of the invention) because only one test tone signal is used (e.g., 3000 Hz).

FIG. 1C shows a prior method of measuring the amplitude (but not phase or frequency modulation) of intermodulation distortion components on a two tone signal. In one example, a 60 Hz signal, 5, is combined with a 7000 Hz signal, 7, via a circuit 6, which is coupled to the device under test, DUT, 25, such as an amplifier. The output of the amplifier is then coupled to a filter, 8, to remove the 60 Hz component and pass a signal around 7000 Hz. The intermodulation distortion components are signals 60 Hz above and below the 7000 Hz signal from the DUT's output. These intermodulation distortion components then are measured for amplitude via an amplitude detector such as an amplitude modulation (AM) envelope detector, or an amplitude measuring system as denoted by block 9.

Note that there is another other two-tone intermodulation test such as coupling a 19 KHz and 20 KHz tone to the DUT to measure only the amplitude of third (and or second) order intermodulation distortion components.

Yet another object (of the invention) is to measure phase or frequency modulation effects of intermodulation distortion signals or tones, and or the test tones or signals from the DUT's output. The measuring of the phase and or frequency modulation effect(s) (e.g., of the any test signal frequencies and or of any distortion products from the DUT) is distinguished from (the prior art method of) measuring the amplitude or magnitude of intermodulation distortion products.

Another object (of the invention) is to measure the amplitude modulation/variation of any phase or frequency modulated signal from the DUT (e.g., with multiple signals).

FIG. 2 shows a prior art standard test method for measuring differential phase or gain in a composite color video signal. Measuring different (color) gain is important to assess a shift in color saturation with changes in luminance or brightness values. And, measuring differential (color) phase is important in assessing a shift in color hue or tint with changes in luminance or brightness values. A low frequency luma signal, 11, (e.g., staircase signal of ramp signal with a repetition frequency of 15.734 KHz or 15.625 KHz) is combined with a chroma color subcarrier signal, 12 (e.g., 3.58 MHz or 4.43 MHz). The chroma and luma signals are combined via circuit 13 and are coupled to a video equipment, 14. The output of 14 is coupled to a differential phase and or gain meter, 15, which filters out the luma signal, and uses a phase detector (e.g., no FM detector) to determine/measure phase or gain variations as function of varying brightness (luma) levels, which lead to color variations. The output of differential phase and or gain meter 15, which may be coupled back to the input of 15 (dashed line), may be coupled to a TV, 16, for monitoring.

FIG. 2 is intended for a video picture assessment for a color TV signal and its effects on color distortion. On the other hand, an object of the invention is to assess the effect of differential phase modulation on an audio signal, which can lead to a sonic (blurring) effect of music. Since measuring differential phase and or gain in an audio signal does not lead to the prior art's FIG. 2 intent to assess color distortion on a color TV signal (which is subsequently viewed on a TV set), the use and or objective of the invention is distinguished from the prior art shown in FIG. 2.

Another object (of the invention) is to assess the frequency variations of an audio signal that can lead to a sonic (blurring) effect. Note that this audio effect is not heard via a color TV signal (e.g., the video signal is beyond the bandwidth of audio hearing). Also, there is no "differential frequency" measure-

ment for video signals. Thus, an embodiment (of the invention) is distinguished from video testing.

Also combining the prior art shown in FIGS. 2 and 1 will lead to a Wow and Flutter meter operating out of range because the video signal (>15 KHz) is too high in frequency. Applying the prior art 3000 Hz tone of FIG. 1 into the differential phase/gain meter of FIG. 2 will not work, because this tone is too low in frequency for video testing.

FIG. 3 shows an example (of the invention) wherein multiple signal sources 21, 22, and or 23 are combined or coupled by a circuit 24. Note that there may be (up to) N signal sources supplied to block 24. The output of combining circuit or apparatus 24 is then coupled to the DUT, 25, which may include at least one amplifier (e.g., an amplifier can be at least one amplifier stage), analog to digital converter, digital to analog converter, device (e.g., of previously mentioned), signal processor, and or storage apparatus. Because of the multiple tones coupled into the DUT, the output of the DUT 25 will (for example) include phase and or frequency modulation (e.g., a form of new distortion) for one or more signals at its output. The output of the DUT, 25, is then coupled to a modifier circuit or apparatus 26. Modifier 26 reduces or removes at least one interfering signal for measurement of phase and or frequency modulation. And the output of modifier 26 is then coupled to a Wow and Flutter meter 27 or to block 28, a phase and or frequency detector/discriminator.

The Wow and Flutter meter 27 may be of conventional type such as a Leader LFM-39A or a modified version of it to extend its frequency range. For example, a conventional Wow and Flutter meter measures frequency deviations based on a 3 KHz test signal with a 300 Hz bandwidth for the recovered frequency modulation effect(s). Thus for example, a Wow and Flutter meter can be modified for measuring frequency modulation effects of a 15 KHz test signal, with a 1500 Hz (or more) bandwidth for recovering the frequency modulation effects. Of course (these or) other (test) frequency signals may be used and or other recovered bandwidths may be provided (e.g., for the FM detector).

FIGS. 4A to 4F shows various ways of modifying a signal from the DUT.

FIG. 4A is a bandpass filter, 31, to remove or reduce the amplitude of one or more signals out of its bandpass and pass through a signal or tone to the phase and or frequency (modulation) detector/discriminator (or Wow and Flutter meter). FIG. 4A for example may be set to tune to any frequency component from the output of the DUT, which may include any of the (input) test signal frequencies, and or any distortion products generated from the DUT. Thus, any of the tuned frequencies mentioned may be coupled to a detector for measuring modulation effects such as in phase and or frequency modulation (effects). Bandpass filter 31 may be set for a particular bandwidth in the pass-band (for example, to allow sufficient or substantially accurate measurement of differential phase and or frequency modulation distortion).

Using a filter, for example at least one band pass filter, and at least one detector (phase, frequency, and or amplitude detector) can reveal phase and or frequency modulation (or even amplitude modulation as well) of any (one or more) signal component from the DUT.

FIG. 4B shows an alternate way to measure the modulation distortion. A high pass filter, 32, is used to reduce or to remove unwanted signals, at least one lower frequency signal so as to facilitate a more accurate detection of phase and or frequency modulation distortion from the DUT. One advantage of using a high pass filter is that a wider bandwidth of phase and or frequency detection/discrimination can be achieved over a

simple band pass filter. However, a more complex band pass filter can yield similar wider bandwidth recovery for the detector.

Although there are many types of frequency detectors which may be used for at least one embodiment of the invention such as (tuned circuit) ratio detectors, discriminators, peak differential, phase lock loop, and or quadrature detectors, there is also a pulse counter FM detector.

The pulse counter FM detector generates a fixed width or duration pulse of a set amplitude and is triggered by the incoming signal at a particular slicing level. For example, if the higher frequency signal is adequately separated from the other signals at the DUT's output, a limiter circuit or comparator may generate a square wave signal. This square wave signal then can be coupled to a timing generator such as one shot or half shot circuit. The output of the timing generator then produces a train of pulses of fixed width. If the higher frequency signal is incurring an FM effect, then the number of pulses per time will vary from the timing generator, which in turn when integrated or low pass filtered, will convert the frequency deviation (FM effect) into a demodulated output signal.

In another example (of the embodiment) for the detector, the positive and negative going edges of the square wave signal are coupled to two timing generators. The timing generator outputs are combined (e.g., a logic OR), which yield a pulse train of twice the frequency of the higher frequency signal (e.g., FH in FIGS. 7, 8, and or 9), which allows for wider band FM demodulation. This form of "double edge" FM demodulation is commonly used in analog video recorders. (For example see FIG. 17, latter portion).

For example, it is widely known in FM analog video recording systems, that as long as the first sideband (e.g., upper sideband) is recovered in the FM signal, a wide frequency response is achievable. For example, at a carrier frequency of about 8 MHz, a modulating frequency of about 4.2 MHz may be recovered with little distortion via this double edge technique.

Thus, an example would have a sharp cutoff high pass filter at about 1.6 KHz as the modifier block 26, and a double edge FM detector as block 28. The output of combiner 24 will have a higher frequency signal of 3 KHz or more, and a lower frequency signal of less than 1.55 KHz. The high pass filter will remove and or sufficiently attenuate any frequency at 1.55 KHz or lower. With this example, then it is possible to measure FM effects of the DUT caused by the lower frequency signal up to about 1.55 KHz even though the higher frequency signal (e.g., "carrier" into the detector) is at 3 KHz. In other words or in general, FM effects can be recovered (from a 3 KHz (carrier) signal or higher frequency) up to about a little more than one half of its own (e.g., "carrier") frequency (e.g., 1.55 KHz demodulated from a 3 KHz signal, but other frequencies may be provided or used).

FIG. 4C shows a low pass filter, 33, as a modifier, which may be used to couple the lower frequency signal into a detector to measure phase, frequency, and or amplitude modulation effects. Also the low pass filter will remove the higher frequency signal while passing the lower frequency signal, (such) as a synchronizing signal from the DUT's output. (For example, see FIG. 12.)

FIG. 4D shows a notch filter, 34, as a modifier. This notch or band reject filter may provide for rejecting or reducing one or more signal frequencies.

For example, a notch may reject the lower frequency tones and (or) any or all of the lower frequency signal's harmonics or other distortion products (e.g., intermodulation distortion components). In one example, the notch filter then passes at

least one of the higher frequency signal's components (e.g., fundamental, harmonic(s), and or intermodulation distortion product (s).)

FIG. 4E illustrates a filter, 35, as a modifier. This filter may be any combination of the previously mentioned filters. FIG. 4E may denote a comb filter to pass through or reject one or more frequencies. In general, FIG. 4E represents a filter comprised of any combination of software, firmware, digital, and or analog techniques.

Note that any filter described in FIGS. 4A to 4E may be phase compensated for a flatter group delay characteristic. For example, phase equalization may be employed. Generally, a more linear phase response or flatter group delay characteristic will yield less distortion in PM and or FM demodulators (e.g., demodulators=detectors).

FIG. 4F denotes a nulling and or reducing circuit (method), 36, which may include cancellation.

One such method is to add a substantially out of phase signal or signals to at least partially cancel out one or more signals.

For example, circuit 36's input may be coupled to the DUT's output and a second input, 37, comprise of a lower (or higher) frequency signal from blocks 21 or 24 of FIG. 3. With the signal coupled to input 37, the phase is altered and amplitude is set to cause a cancel of at least part of the lower frequency signal from the DUT's output. In this example, the output of circuit 36, would comprise substantially the higher frequency signal(s).

Again, block 36 (or any of the blocks in FIGS. 4A to 4F) may be implemented in the analog, digital, and or software domain.

FIG. 5 shows a tunable receiver (or tuner), 41, with an FM, PM, and or AM detector. Block 41 then tunes into any of frequency of the spectrum to measure modulation effects on any of the signals produced by the DUT's output. The DUT's output may have the higher and lower frequencies and or their distortion products, harmonic and or intermodulation components. The tunable receiver 41 may be implemented with at least one filter, mixer, amplifier, oscillator, and or detector.

When the tunable receiver 41 is implemented to cover the audio range or higher, frequency, phase, and or amplitude modulation effects can be measured, stored, and or computed.

Block 41 and or any other part of the invention such as the blocks in FIG. 3 may be scaled for radio frequencies as well. In superheterodyne radio receivers, it is well known that the phase noise of a local oscillator can cause degradation in signal to noise of the demodulated signal. Thus this invention when scaled up to radio frequencies can measure frequency, phase, and or amplitude modulation effects on a receiving signal cause by other RF signals.

For example, an antenna picks up many channels of different frequencies (e.g., multiple signals). In some radio receivers, there is a varactor (variable capacitance) effect from the semiconductor mixer, RF amplifier, and or some tuned circuits. This varactor effect, which causes a change in capacitance versus a voltage across the semiconductor, then can induce incidental phase noise or extra frequency modulation, which can lead to extra noise at the demodulated output. Thus this invention can be applied to RF systems to measure phase noise for example (when two or more signals are involved).

FIG. 6 shows an alternative way of measuring standard distortions. Standard prior art tests measure harmonic, intermodulation at a single bias point of an amplifier or audio processor. Block 42 tests for harmonic and or intermodulation distortion products at a varying bias level. This varying bias level test via the block 42 can also be used to measure noise

(e.g., noise output at various bias levels). The distortions and or noise measurements can then be stored, displayed, and or computed.

FIG. 7A shows one example of multiple signals applied into a DUT. The lower frequency signal has a frequency FL and a higher frequency signal has a frequency FH. In this example the amplitude of the FL signal is larger than the FH signal. However, the amplitude of either or both may be set to any level or any selected level.

FIG. 7B shows an output of the DUT, which may include an amplifier, device, at least part of a digital system, audio system, and or an RF system (e.g., which may generate harmonic and or intermodulation distortion due to a non-linearity). FIG. 7B then shows that there can be phase and or frequency modulation effects on the FL signal, FH signal, and or at least one harmonic of the FH signal, as denoted by the horizontal double arrows across each component.

For example the double arrows shows a ΔFL , ΔFH and $\Delta 2FH$ as a deviation or shift in frequency for those signals with frequencies FL, FH and a harmonic of FH. By use of a modifier (and or) detector, the deviation or shift in phase and or frequency may be measured.

It should be noted although not shown in FIG. 7A, it is possible to provide to the (phase or FM) detector (e.g., for measuring phase and or frequency modulation) any harmonics of FL and or FH, and or any intermodulation distortion component based on FL and FH.

FIG. 8A shows another example of multiple tones/signals, this time with more than two signals. Again, although the FL signal is denoted as larger in amplitude than the FH1 and FH2 signal, (other) amplitude levels may be set for any or all of the signals. In FIG. 8A, the use of more than two signals allows for measuring at least one intermodulation distortion component based on two higher frequency signals such as FH1 and FH2.

FIG. 8B then shows an example of at least some intermodulation and or harmonic distortion components based on FH1 and FH2 (e.g., caused by a non-linearity of a DUT). Not shown in FIG. 8B are other (e.g., intermodulation and or harmonic) distortion components (that may be coupled to a detector) based on any combination of FL, FH1, and FH2 (e.g. caused by non-linearity from a DUT). In FIG. 8B phase and or frequency modulation effect(s) can occur in the following but not limited to:

(FH2-FH1) (a second order intermodulation difference frequency),
 FL,
 (2FH1-FH2) (a third order intermodulation difference frequency),
 FH1,
 FH2,
 (2FH2-FH1) (another third order intermodulation difference frequency).

Thus any or all of the above frequency components may be coupled to one or more (e.g., phase and or frequency) detectors. Modifier 26 may be used to ensure a more accurate measurement from any of the detectors.

The double horizontal arrows denote a representation of the shift or deviation (e.g., in terms of phase and or frequency) across each signal component.

Also, the signal deviation or shift (such as frequency deviation or phase shift) is denoted by the following:

$\Delta(FH2-FH1)$ or ΔFH IM2D
 ΔFL
 $\Delta(2FH1-FH2)$ or ΔFH IM3DL
 $\Delta FH1$
 $\Delta FH2$

17

$\Delta(2FH2-FH1)$ or ΔFH IM3DU
 $\Delta nFH3A$
 $\Delta nFH3B$
 ΔnFL

wherein $n \geq 2$ for example

Of course other distortion products may be coupled to the detector, such as sum and or difference intermodulation distortion components (e.g., of Nth degree distortion and of M signals) for measuring frequency and or phase modulation (and or amplitude modulation). Note that other or higher order harmonic distortion products or signals may be coupled to a detector.

FIG. 9A shows an example of a multiple signal test. In this example, the lower signal frequency FL3 is chosen to be lower than the frequency (FH3B-FH3A). These signals are coupled to the DUT.

FIG. 9B then shows an effect of the multiple tones on a DUT's output signal. In this example, the double arrows for each signal frequency designate a phase and or frequency modulation effect. FIG. 9B then shows that a modulation effect may be present not only at the input signal frequencies, but any or all of the distortion products. The distortion products shown but not limited to are the second order intermodulation distortion from FH3A and FH3B such as (FH3B-FH3A), third order intermodulation distortion products 2FH3A-FH3B, 2FH3B-FH3A, and or harmonic distortion products, nFH3A and or nFH3B (e.g., $n \geq 2$). These distortion products include any Nth order intermodulation and or harmonic distortion component(s).

Not shown in FIG. 9b, but can be included are the harmonics of FL (e.g., nFL) and the intermodulation distortion components related to FL and FH3A FH3B (FH3A+/-n'FL, FH3B+/-n'FL, 2FH3A+/-n'FL, 2FH3B+/-n'FL, and or other distortion products, wherein $n' \geq 1$). By using a modifier and or receiver/tuner 41, any of these signals or other signals (not shown) may be coupled to a detector for measuring phase and or frequency modulation effects. An amplitude measuring system such as a magnitude detector may be use to measure amplitude effects of the phase and or frequency modulated signals.

For each signal component in the spectrum a modifier such as modifier 26, may "process" the other signals as to reduce interference to a detector. The modifier may comprise filters and or cancellation methods/apparatuses. For example, in some DUTs, the frequency deviation may be large (such as due to any non-linearity, for example, any combination of cross over distortion point(s), near cut off, near saturation, or the like). With possible large frequency modulation effects from the DUT, it is desirable to have sufficient (to maximum) bandwidth around the signal that is coupled to the detector. It may be desirable to ensure sufficient attenuation of interfering signals.

For example, in FIG. 7B, we see that there are dotted lines denoting the 2nd, 3rd, and 4th harmonic of lower frequency signal whose frequency is FL. To optimize in measuring the recovered modulation (e.g., frequency modulation, FM and or phase modulation, PM) of FH, a modifier can comprise of a filter (and or cancellation circuit) to essentially remove or reduce amplitude of FL, 2FL, 3FL, and (or) 4FL (which may include 2FH). The filter can be made of a comb type band reject filter, multiple frequency notch filters, high pass, band pass and or notch filter, or the like.

From FIG. 7B, one can see it may be desirable to at least attenuate 3FL and or 4FL to avoid interfering with the (e.g., frequency and or phase modulation) detection of FH. The previous methods described above allows a wider bandwidth of recovery, whereas if one uses a narrow bandwidth band

18

pass filter around the FH frequency, only a portion of the frequency and or phase modulation will be recovered. The reason is that a narrow band filter around an FM signal restricts recovery of the modulation.

In some cases a band-pass filter (of selected bandwidth) tuned to any signal component from the DUT's output may be sufficient for measuring phase and or frequency modulation effects (e.g., via a demodulator or detector).

FIG. 10 shows an apparatus/method, 50, to generate fundamental and or distortion products for reducing at least one interfering signal when the DUT is coupled to a detector. With the apparatus/method 50 combined with a modifier 26 or 26A, at least some cancellation occurs in one or more interfering signal.

An interfering signal for example, is a signal that reduces the measurement accuracy of (phase and or frequency) modulation effects (of a particular or selected frequency) from the DUT's output. For example in FIG. 7B if the 4th harmonic of FL is close in frequency to FH, then the subsequent detecting for modulation effects will be inaccurate. Because 4FL falls into a band pass of FH, an interference condition occurs that may cause an erroneous measured (frequency and or phase) modulation of FH. In general, a "carrier" signal may be the signal of interest for measuring a modulation effect. In this example, the signal from the DUT with frequency FH is considered as the carrier signal, and a harmonic of the signal FL that has a frequency of 4FL (which would be generated by a non-linearity from the DUT) is considered an interference signal.

In block 50, an input signal is (then) coupled to an optional filter, 64. The input signal is coupled to a distortion generator 51, which can comprise a waveform shaper, mixer, and or nonlinear function. The input signal may be a signal from the blocks 21,22,23, and or 24, or FIG. 3, and or the input signal may be from the DUT's output. Optional filter 64 may for example, then pass a particular signal through such as FL or FH.

In one embodiment, distortion generator 51 may generate harmonic distortion. In another embodiment, generator 51 may generate intermodulation and or harmonic distortion. The output of generator 51 is then coupled to a distortion product extractor, 52, which then output various distortion products (e.g., 2nd, 3rd, and or nth order harmonics (and or intermodulation components)) to a scaling factor and phase compensator or shifter apparatus comprised of blocks 53, 54, 55, 56, 57, and 58. Note as illustrated in FIG. 10, there are up to three outputs from the distortion extractor 52 shown, but more outputs may exist to couple to more scaling factor and phase compensator or shifter apparatuses.

The output of (any number of) the phase compensator circuits or apparatuses (e.g., 56 to 58 and or 62) is coupled to a combining apparatus 61. Also coupled to combining apparatus 61 is the output of phase shifter 62 via scaling block 63, which in this example represent a fundamental frequency signal. The output of combining apparatus 61 then may include any combination of fundamental and or (one or more) distortion products (e.g., harmonics and or intermodulation components), which can be used to then at least reduce interference signal prior to detection.

It should be known that the input of block 50 may contain more than one tone or signal. In this example, distortion generator 51 can generate intermodulation and or harmonic distortion products, and distortion extractor 52 can then extract intermodulation and or harmonic tones or signals. And the output of block 50 then can be comprised of harmonics and or intermodulation signal frequencies, which may be

used accordingly to reduce a signal close (e.g., in frequency) to a (particular or selected) carrier (e.g., frequency) signal for detection.

By setting (any of) the scaling factor(s) K1-Kn, any test signal and or any distortion products may be reduced in amplitude or removed via a cancellation effect.

Also note that reducing amplitude or attenuating may include removal.

FIG. 11 then shows an example of block 50 of FIG. 10 for measuring a modulation effect from a DUT. In this example, signals including FL and FH (but not limited to) are combined or summed via a combining circuit 24. Signal FL is coupled to block 50, which outputs any combination of fundamental and or distortion products (e.g., 2nd, 3rd, 4th, and or nth order harmonic and or intermodulation). The output of block 50 then has via the scaling block(s) close to the amplitude of the harmonic distortion (and or intermodulation distortion) from the DUT's output. The output of block 50 may then have (essentially) the same or opposite phase of the fundamental and or harmonic(s) (and or intermodulation distortion product(s)). The DUT output is coupled to an input of the modifier 26 or 26A, and another input of the modifier is coupled to block 50's output. If the modifier is a summing apparatus, then the phase shifter/compensator blocks from block 50 are set to be about out of phase to cancel signal with frequency FL and or at least one harmonic of the signal with frequency FL. And if the modifier is a subtracting apparatus, the output of block 50 will be set for about the same phase so that the modifier may reduce or cancel the frequencies at FL and or its harmonics.

With frequency components around FL and or its harmonics reduced sufficiently at the output of the modifier, the frequency component around FH (in this example) is then coupled to the Wow and Flutter meter and or FM/PM detector (e.g., for a wider frequency range of the recovered (FM and or PM) modulation effect on the signal with frequency FH).

FIG. 12 shows an example waveform for an audio or RF test signal to measure for phase and or frequency modulation effects. An optional sync signal, which may be bipolar as shown by numeral 65a, 65b, can also be a unipolar sync signal (e.g., such as 65a or 65B). A lower frequency waveform such as a ramp or sawtooth signal is shown at 67. A high frequency reference signal is shown at 66, which may contain one or more packets of more than one frequency signal. Also shown is a higher frequency signal, 68, added or superimposed on a portion of the lower frequency signal, 67. Signal 68 may be comprised of more than one frequency in sequence and or in combination. Signal 67 may be comprised of a sinusoid or arbitrary waveform.

Example frequencies of the waveform shown in FIG. 12 can have period of the waveform of $\frac{1}{30}$ of a second, the low frequency ramp, 67, may be about 20 to 30 milliseconds in duration, and sync pulse width (65) may be 2 to 5 milliseconds in duration. Reference signal 66 may have a duration of 1 to 5 milliseconds and with frequencies of 5 KHz, 7 KHz, 10 KHz, and or 15 KHz. Signal 68 may have frequencies similar or the same as reference signal 66. Amplitudes of each signal, 65, 66, 67, and or 68 may be set to any level.

Of course, other waveforms, signals, time durations, and or amplitudes may be used.

One advantage of a signal such as in FIG. 12 is that at least one reference high frequency signal is carried along with this test signal (that then does not require an external reference source such as a reference signal from generators 21, 22, or 23 of FIG. 3), which allows testing of equipment that may include storage or memory, or wherein the output of the DUT is not synchronized with the input. For example, in a storage

system, the output of the DUT may output the input signal with a slight different frequency "error" (e.g., 1000 Hz in, 1001 Hz out). Thus, taking a reference phase from an FH signal at the input to make phase modulation measurements will be invalid. But instead, the reference signal 66 is used to generate a continuous high frequency signal for phase detection, wherein the phase (modulation) measurement would be valid since the reference signal (e.g., 66) would encounter the same slight frequency "error" output caused by the DUT.

Note that although FIG. 12 may look similar to a video signal circuit, the present use for devising such a signal is to measure modulation distortion in audio and or RF systems or devices.

On the other hand, in video a (prior art) video test signal is used to measure color saturation or tint effects on a color subcarrier TV signal with a luma signal.

However, in audio, a signal such as shown in FIG. 12 would be used to measure phase and or frequency modulation effects that would cause a sonic or audible characteristic. And in an RF system, extraneous noise may be measured because of phase and or frequency modulation effects, which lead to phase noise that can degrade signal to noise ratio.

Note that FIG. 12 is an illustration by way of example only, and other waveforms may be synthesized. One aspect of FIG. 12 is to carry at least one higher (and or lower) frequency reference signal along with at least one test signal. A synchronizing signal may be added to the test signal, but may not be required. For example, recovering a lower frequency signal via filtering or reducing the amplitude of the higher frequency signal(s) can provide a sync signal. Alternatively, removing or reducing the lower frequency signal may allow using one or more of the higher frequency signal(s) to provide a sync signal.

FIG. 13 shows an illustration of an apparatus, 80, to generate a test signal (e.g., FIG. 12 or other waveform) for measuring modulation effects on at least one particular signal or tone.

One or more reference timing signals is provided by blocks, 81, 82, and 83. Block 83 represents that up to (n or "n0") reference timing signals can exist. These timing signals may include a synchronizing signal, and or at least one reference high and or low frequency signal in a form of a packet or packets or an arbitrary waveform.

Test signal sources (that may be comprised of low, mid, and or high frequency signals) are provided by blocks 84, 85, and or 86. Again, block 86 indicates that there may be up to (n or "n1") test signal sources.

A combiner, adder or inserter block 87 receives the reference timing and test signal sources to output a test waveform via 88. This test waveform can then resemble part of or all of FIG. 12, or this test waveform from 88 may produce another waveform.

Also shown is block 89, which allows synchronizing the various reference and or signal timing sources. For example, block 89 may provide the order (e.g., sequence) when each reference and signal source occurs in a generated waveform at the output 88.

Block 89, 88, and or 80 may also provide sequence a different waveform at start of the next reference timing period (e.g., synchronizing or reference frequency signal).

FIG. 14 shows a measurement system, 90, that utilizes a test waveform from generator 80. Output 88 is coupled to the input of a DUT, 25. The output of the DUT is then coupled to an input of 90. Thus the DUT's output is coupled to a timing separator 91, and one or more reference signal regeneration circuits, 92 and or 93. Block 93 represent that there can be as many as "n" reference signal regeneration circuits. An

example of the reference regeneration circuit (e.g., phase lock loop, oscillator, or the like) is to provide signal (e.g., of a (fixed) phase and amplitude) that extends in duration beyond the reference signal packets, such as **66** of FIG. **12**. The output of one or more reference signal regeneration circuit is then coupled to one or more mixer or multiplier or non-linear circuit (e.g., **94** and or **95**) to provide phase detection of the DUT's output (e.g., from a selected signal from DUT **25**). So circuits **94**, and or **95** receive(s) a coupled signal from the DUT's output via a modifier such as **26** or **26A**. The modifiers remove an interfering signal component prior to the input of circuits **94** and or **95**. The output phase detector **94** and or **95** is coupled to a filter (e.g., **96** and or **97**) of particular bandwidth.

The output of filter **96** and or filter **97**, and a timing signal from timing separator **91** are coupled to a measurement system, display, meter, and or computer to measure, display and or compute the DUT's phase variation as a function of a lower frequency signal such as a ramp or other waveform. If the slope of the phase or derivative of the phase variation is taken (e.g., by a differentiator circuit and or by computation), a frequency modulation variation as a function of the lower frequency signal may be provided.

FIG. **15** shows an example of using waveform generator **80**'s output to measure frequency modulation effects from a DUT. The signal **88** is coupled to the input of the DUT, **25**, whose output is then coupled to system **100**, which includes a timing reference circuit **91** and a modifier **26**. The output of the timing reference circuit **91** is coupled to an optional timing circuit **101**. The output of the modifier **26** is coupled to an FM detector, **102**. Display, meter, and or computer **103** is coupled to the timing reference signal and to the output of FM detector **102**. Block **103** then can measure and or display a frequency deviation or shift of a signal or tone as a function of a lower frequency signal such as signal **66**. By integrating (e.g., via an integrator circuit and or by computation) the FM detector's output, a phase variation measurement may be provided. Note that one or more FM detectors may be used for system **100**.

FIG. **16** shows another example for testing for modulation effects based on two or more frequencies. Block **111** represents one or more complex signals. A complex signal may include music. For example, block **111** may include a violin or other musical instrument's note or notes. In a violin, an "A" 440 Hz note has a fundamental frequency much larger in amplitude over its harmonics.

For this example, in general, this complex (440 Hz) signal is then coupled to a DUT via line **113**. The output of the DUT is then coupled to a modifier, **26**, which reduces the amplitude of the fundamental and or other harmonics. A (remaining) selected harmonic (e.g., 10th harmonic at 4400 Hz or 20th harmonic at 8800 Hz) is to be coupled to a Wow and Flutter meter **27** (e.g., a modified Wow and Flutter meter to measure beyond a standard 3 KHz signal), a phase and or FM detector **28**, and or a tuner/receiver, **41** (for measuring modulation effects such as PM and or FM and or Wow and Flutter). It should be noted in general, a particular musical note or signal has a fundamental frequency component and various harmonics. To measure the "nth" harmonic for phase or frequency variation, prior to coupling the musical signal to the input of the DUT, it may be preferable to remove or attenuate any harmonic(s) near/around the "nth" harmonic. For example, attenuate or filter out the "(n-1)th" (and or "(n-2)th") and or "(n+1)th" (and or "(n+2)th") harmonic of the musical signal prior to coupling to the input of the DUT.

Note the tuner/receiver **41** may be coupled to the output of the DUT, and tuned to the various harmonics and or fundamental to measure for modulation effects (e.g., phase and or frequency shifts).

In another variation or example of this test method and apparatus utilizing one or more complex waveforms from block **111**, the output thereof is modified via a modifier **112** to reduce or remove one or more (signal) frequencies prior to coupling to the DUT. The output of the DUT is then coupled to the modifier **26** or **26A** to remove any interfering signals prior to meter **27** (e.g., for Wow and Flutter measurement on a selected frequency) and or FM detector **28** (for measuring modulation effects). Tuner/receiver **41** may be coupled to the output of the DUT (or to the output of modifier **26** or **26A**) for measuring any modulation effects (e.g., phase and or frequency shifts) of any signal from the DUT.

It should be noted that the complex signal source **111** may include one or more "voices" or musical instruments.

Thus, source **111** may be substituted for any of the signal sources previously mentioned (e.g., **111** may substitute for the sources **21**, **22**, and or **23**; **67** and or **68**; **84**, **85**, and or **86**; or the like).

It should be known that a source such as **111** may be used in conventional testing such as harmonic and or intermodulation distortion measurements with or without a variable bias condition.

FIG. **17** shows various ways to detect or demodulate an FM signal. A signal **125** coupled via the DUT's output (e.g., and is sufficiently free of interfering signals for detection of a particular carrier or selected signal/tone) is coupled to an amplifier and or amplitude limiter amplifier, circuit **121**. The output of circuit **121** is coupled via an optional filter **122** to a detector **123**. Block **123** may be implemented in terms of a phase detector, quadrature detector, ratio detector, slope detector, regenerative detector, discriminator, phase lock loop, peak differential detector, and or a frequency to voltage/current converter.

One example of a frequency to voltage/current converter is shown by blocks **126**, **127** and **128**.

A second example of a frequency to voltage/current converter is shown at numerals **126A**, **127A**, **127B**, **129**, and **128B**. Both examples shown are also known as pulse counter (FM) detectors. In particular the second example (via block **128B**) is used in analog video recorders, and has an advantage of recovering a wider bandwidth than the first pulse counter detector (via block **128**) or many of the examples of detector **123**.

For the first (example) pulse counter detector, a (limiter) circuit **126** is coupled to the signal **125** from the DUT, which may include a modifier **26**, or block **126**'s input may be coupled to the optional filter **122**. The output of amplifier, limiter, and or comparator **126** is then coupled to a timing circuit, which generates a fixed duration pulse (triggered from either edge of block **126**'s output). The output of block **127**, which is a train of fixed width pulses, is coupled to a low pass filter **128**, which then provides a voltage in proportion to the frequency of the carrier or selected signal or tone. If the selected signal or tone shifts up in frequency, more pulses per time will occur and the low pass filter output will increase. If the selected signal or tone shifts down in frequency, less pulses per time from block **127** will occur and the output of low pass filter **128** will decrease.

The second example of pulse counter (FM) detector receives the signal **125** (dashed line) and utilizes both rising and falling edges (e.g., of the selected carrier signal) via the comparator/amplifier/limiter **126A**'s (complementary) outputs. Each **126A** output is coupled to a timing generator **127A**

and 127B, and both 127A and 127B deliver a fixed pulse duration for its output. A logic OR (function) circuit 129 is coupled to each output of the timing generators, and the output of circuit 129 then is a double rate or double frequency FM signal from the selected tone or signal. With the double rate signal, the bandwidth for the low pass filter 128B may be extended (e.g., over filter 128), for a greater recovered information.

In some tests of DUTs that may include crossover, quantizing, and or clipping distortion, the second pulse counter detector (e.g., via 126A, 127A, 127B, 129, and 128B) is more desirable in that the discontinuous (wider band width) nature of the phase and or frequency modulation effect is more faithfully reproduced.

Other types of testing may include a modulated waveform such as AM, PM, and or FM coupled into the DUT with or without dynamic biasing for measuring any extraneous sidebands, and or any deviation from the recovered modulation, which may include harmonic and or intermodulation distortion and or phase and or frequency modulation effect(s). The dynamic biasing may include a period waveform, an arbitrary or programmed waveform, and or at least one modulated signal.

In terms of another signal source or sources, any of the previously mentioned signal sources may be a modulated signal source. As shown in FIG. 18A, a modulated signal source with a modulating signal $m(t)$ and a "carrier" frequency signal $f(t)$ may be used. The output of FIG. 18A or 131 may then provide an amplitude, frequency, and or phase modulated signal (e.g., for coupling to a DUT). The output of 131 may serve as a signal source for any waveforms in FIG. 12 (e.g., 131 output, a modulated signal may be used for 66, 67, and or 68). (It should be noted that a modulated signal may include a zero modulation.)

For example, an amplitude modulated signal (e.g., for coupling to a DUT) may include single sideband, double sideband suppressed carrier, double sideband with carrier, and or a vestigial amplitude modulation. Amplitude modulation may include pulse amplitude modulation and or a variation of a carrier signal's amplitude level.

For phase modulation, examples may include I and Q type phase modulation, phase shift keying modulation, or simple phase modulation. Examples of frequency modulation may include narrow and or wide band frequency deviation and or frequency shift keying modulation. Frequency and or phase modulation may include vestigial frequency and or phase modulation.

Other examples of modulation may include pulse code modulation (e.g., for block 131)

In an example for amplitude modulation, a continuous tone signal of 3 KHz and an amplitude modulated 16 KHz signal was combined and coupled to a DUT (e.g., a two transistor amplifier of previous mention.). In the previous example, it was shown experimentally that a lower frequency signal combined with a higher frequency signal caused an induced phase and or frequency modulation effect on the higher frequency signal. In this example, the amplitude modulated higher frequency signal caused an induced phase and frequency modulation effect on the lower frequency signal. In one experiment a 100 Hz sine wave (e.g., $m(t)$) amplitude modulated a 16 KHz signal (e.g., $f(t)$) to generate this amplitude modulated signal that is combined with a 3 KHz signal for the DUT's input signal. With a band pass filter or modifier (e.g., to remove the 16 KHz amplitude modulated signal and pass through the 3000 KHz signal) coupled from the output of the amplifier or DUT to a Wow and Flutter meter, and it was found that 0.03% Wow and Flutter was measured. Again, this

is an unexpected result (e.g., normally it would be expected that an electronic amplifier has Wow and Flutter=0.000%, or an amplifier should exhibit no Wow and Flutter) in that a higher frequency signal induces a phase and or frequency modulation onto a lower frequency signal. It should be noted that a frequency, (and or phase) modulated signal may have been used to modulate a signal. For example, many devices may exhibit a variation in frequency response. A frequency (or phase) modulated signal will then cause a incidental amplitude modulation effect when the device has a variation in frequency response, which will cause a (differential) phase or frequency modulation effect on another signal from the device. For example, a envelope variation of a carrier frequency signal can induce phase or frequency modulation effect(s) on another signal. The envelope may include two or more signals added to form an envelope to cause a modulation effect (e.g., on another signal such as a lower and or higher frequency signal).

FIG. 18B shows that any of the signal sources may include a noise generator. The noise source as a signal source may include filtering to shape one or more types of frequency responses. In one example, a noise source may be substituted for any of the previously mentioned signal sources and or used for a modulating signal source such as $m(t)$ in FIG. 18A.

A DUT or device under test may include an amplifier (stage), processor, recorder, transducer (e.g., microphone and or speaker, earphone, or the like), a mechanical device, an electromechanical device, an optical device, an electrical device, a magnetic device, and or an electromagnetic device. Any of these examples may be measured for an induced phase and or frequency modulation effect cause by one or more frequencies. FIG. 18C shows such examples of any DUT.

In an example of using an electromechanical device or transducer, a microphone may be tested for induced phase and or frequency modulation by sonically generating two or more sounds of different frequencies into the microphone and then outputting the microphone's signal to a detector and or modifier and detector for measuring phase and or frequency modulation effect(s). The multiple frequency sounds for example may be generated by musical instruments, and or loud speakers. In an example of using a loudspeaker or speaker system, signal(s) of multiple frequencies may be applied to a loudspeaker or loudspeaker system. The amplifier driving the loudspeaker would have to generate low amounts of induced phase and frequency modulation distortion itself. A method to avoid the need of a "perfect" amplifier is to use one amplifier for each (e.g., single) frequency signal and or to use a separate speaker for each amplifier. For example, for a two (or n) signal test, two (or n) amplifiers and two (or n) speakers are used. This way there is no induced phase or frequency modulation effect from the amplifiers or from the speakers since each item handles a single frequency. The multiple speakers then generate multiple sound signals to the microphone for testing in terms of a modulation effect (e.g., phase and or frequency).

So transducers such as loudspeakers, phonograph pickup cartridges, and or microphones (or other devices) may be tested for differential phase and or (differential) frequency modulation effect(s).

The invention or an embodiment is not limited to electrical devices. Mechanical devices may be tested similarly. Optical devices with different wavelength sources entering the optics may output a shift in wavelength caused by least one of the entering wavelength sources.

In the instance of magnetic or electromagnetic devices, examples would include waveguides and or antennas. For example, nonlinear effects of dielectrics may cause an induced phase and or frequency modulation effect. Some

types of inductors and or transformers may be included as examples of magnetic and or electromagnetic devices.

In terms of an RF or radio frequency system, any of the embodiments are applicable. For example, in a broadband front end section of a receiver (e.g., broadcast or shortwave or higher frequency such as VHF or UHF) a lower frequency signal may induce a phase and or frequency modulation effect on receiving a higher frequency signal (or vice versa where by a higher frequency (RF) signal may induce a phase and or frequency modulation effect on a (received) lower frequency (RF) signal.) For example in AM broadcast, which has a range of 535 KHz to 1605 KHz, a large amplitude signal at 540 KHz can affect a received signal of 1600 KHz if the front end is broadband and uses a solid state device. Under a large signal condition, the solid state device has a varactor effect, which changes capacitance or reactance versus a voltage swing. The lower frequency signal at 540 KHz causes a modulation effect on the reception of the higher frequency 1600 KHz in terms of adding extra phase noise.

Any of the embodiments is applicable to electromechanical systems as well. For example, recorders or players can be tested for induced phase and or frequency modulation distortions caused by multiple input signals. Some players and or recorders may or may not include a mechanical apparatus, but can still be tested by any of the inventive methods mentioned.

A DUT may include audio compression systems, whether for audio processing and or for reduced data rate.

It should be noted that a time (or frequency) scaled version (e.g., time compressed and or expanded) of video test signals such as multiburst, modulated ramp or staircase, multipulse, and or modulated sine squared pulse, is useful in testing various aspects of audio and RF devices (or a DUT). (Note that a varying biasing voltage or current may be used with any of these time scaled video signal provide new methods of testing.) As an alternative, it is possible to provide a video like signal (such as those video signals previously mentioned) into a DUT's input and then sample and store the output signal of the DUT. With the stored signal in memory, one would then clock the memory out at a rate such that a video test equipment (e.g., vectorscope or Tektronix VM700) will be able to measure differential gain and or phase, and or other video performance tests such as luma/chroma delay, K factor, and the like.

In terms of any of the signals from the output of a DUT, any of these signals may be processed. For example, any signal from the output of a DUT may be frequency mixed, modulated, shifted, and or translated to another frequency for measurement. Any signal frequency from the output of a DUT may be divided and or multiplied for a measurement (e.g., for a modulation effect).

One embodiment may be summarized as: A method of measuring frequency or phase modulation effects of an electronic, electromechanical, optical, mechanical, electromagnetic, magnetic, optical, and or transducer device, wherein the device has an input and an output, comprising:

coupling two or more frequency signals into the input; and providing an FM detector and or a phase detector coupled to the output of the device, to measure a frequency or phase modulation effect or frequency or phase shift for one or more frequency signals at the output of the device. It should be noted that the device's output may be coupled to a modifier's input, and the modifier's output may be coupled to a detector.

It should be noted that any or all of the previously mentioned methods, embodiments, and or apparatuses may be implemented in any combination of analog, digital, and or software.

For example, the complex or composite signal(s), modifier, and or detector may be generated in the analog domain, digital domain, and or in software.

As a further note, any or all the embodiments may be used for measuring a phase and or a frequency modulation effect of devices, which may include video devices. So the scope of the invention, may include audio, video, RF equipment, circuits, and or devices. On other note, the signal or signals coupled to the input of the device or DUT may include a source impedance. This source impedance may include any combination of resistive, capacitive, and or inductive element(s). For example, the signal coupled to an RF amplifier may be of moderate impedance such as 300 ohms. And in an audio amplifier, such as a phono cartridge preamplifier, the signal may be coupled to the phono preamplifier via a 500 millihenry inductor, a 500 pico farad capacitor, and a 47 thousand ohm load resistor, which may represent a high impedance signal source. Because RF and audio amplifiers may have input amplifier stages with nonlinear capacitance (or nonlinear inductance), including (a) source impedance for the signal source(s) may be necessary to reveal phase and or frequency modulation effect(s), such as those mentioned in any of the embodiments. It should be noted that the output of any DUT may be loaded. For example, a DUT's output may be loaded with a resistive, capacitive, inductive, and or electromechanical device (e.g., headphone or loudspeaker system). An output load for the DUT may reveal phase and or frequency modulation effect(s).

FIG. 19 shows an embodiment that allows measuring differential phase and or frequency modulation effects on a device under test. Signal generator 21, 22, or 23 is coupled to an optional phase shifting circuit 135. Block 135 may be needed to allow the phase detector 28' to work in its linear region or in its center region for the phase versus voltage (or current) output. It should be further noted that the DUT may include a time delay, which block 135 can be used for compensating to the phase detector. Block 135 may include an oscillator circuit that is coupled to any of the signal generators.

(For FIGS. 19 to 22, block 135 may include or be a phase lock oscillator, a phase lock loop circuit, crash locked oscillator circuit, triggered oscillator circuit, or the like, whose input of 135 is coupled to a signal generator's output e.g., to an input signal source.)

(In FIG. 21 or 22, block 135 may lock onto a fundamental frequency, harmonic or intermodulation distortion signal derived from one or more signal generators.)

The output of 135 is coupled to an input of a phase detector 28'. In general, a selected input signal is coupled to a first input of the phase detector (28'). This selected input signal coupled to the first input of the phase detector is indicative of the frequency passed through by modifier 26. As previously mentioned in FIG. 3, two or more signals are summed via summing/combining circuit 24 and coupled to the device under test (DUT), 25. The output of DUT 25 is coupled to the input of modifier 26. A modifier, 26, (at its output) removes or attenuates one or more signals of (each) selected frequency, while passing through the signal for testing phase and or frequency modulation effect(s). The output of the modifier is then coupled to a second input of the phase detector. The output of the phase detector 28' (or FM detector 27') then is generally coupled to a (suitable) filter for measurement on an oscilloscope or meter. In FIG. 19, block 27' is optional, if Wow and Flutter or a frequency modulation effect is further measured.

An example of FIG. 19 would have in a simplest form, two signals (e.g., 21 and 22, with 23 not used), Gen1 and Gen2.

27

For instance, the frequency of Gen1 of less than the frequency of Gen2 (e.g., frequency of Gen1 \leq 1000 Hz, frequency of Gen2 \geq 3000 Hz). These two signals will be coupled to DUT 25 and the modifier 26 will remove the lower frequency signal, leaving the higher frequency signal to be coupled to the second input of the phase detector 28'. And, Gen2 is then coupled to the first input of the phase detector 28'. The output of 28' may include a filter that removes frequency components of Gen2 or higher for measurement on a scope or meter. On a scope for this example, the triggering is preferably locked via the Gen1 or lower frequency source.

As explained previously for FIG. 3, frequency deviation or modulation effects is measured via 27, and thus, similarly for 27' in FIG. 19 (or 27' in FIGS. 20-22).

FIG. 20 shows an embodiment of the invention including a modulated signal into the DUT. Generator 23' is a modulating signal, $m(t)$ and generator 21' is a carrier signal, $f(t)$. Signals from 21' and 23' are coupled to a modulator, M'ator, which is block 131'. Modulator 131' may include for example an amplitude modulator (or other type of modulator).

The input of the DUT is then coupled to the output of the modulator and signal generator 22. The output of the DUT is then coupled to the modifier 26 to remove/attenuate signals related to the modulator while passing a signal related to generator 22. Again, the output of the modifier 26 is coupled to a second input of phase detector 28' while a first input of phase detector is coupled to generator 22, Gen2 for example. The output of 28' then allows measurement of phase modulation on a frequency of Gen2 based on modulating a (higher) carrier frequency. Also, via 27', frequency modulation effect(s) is measured for frequency deviation or shift on a frequency related to Gen2 based on modulating a (higher) carrier frequency. For measurement on a scope, the triggering signal is preferably coupled to $m(t)$, the modulating signal, which causes the phase or frequency modulation effect on the DUT.

An example of FIG. 20 may include the frequency range of $m(t)$, the modulation signal as \leq 1000 Hz, and a carrier frequency for $f(t)$ as $>$ 5000 Hz, while the frequency range of Gen2 being between the frequency of $m(t)$ and $f(t)$. One example would have the carrier frequency (of $f(t)$ or 21') at 16 KHz, the modulation frequency of $m(t)$ or 23' at 500 Hz, and the frequency of Gen2 at 4000 Hz. In this example, the 500 Hz signal (amplitude) modulating a 16 KHz signal along with a 4000 Hz signal to an input of the DUT will cause a phase (or frequency) modulation at the output of the DUT for a frequency in or near Gen2 or 4000 Hz. Thus, the phase detector 28' receives a first input signal from Gen2 and a second input signal from the modifier, which removes/attenuates the 16 KHz modulated signal (e.g., carrier and sideband signals from the modulating signal), while passing a signal for Gen2 (e.g., 4000 Hz, and neighboring sidebands of Gen2). Of course other (ranges of) frequencies may be used for $m(t)$, $f(t)$, and or Gen2.

It should be noted that a modulated higher frequency signal (such as amplitude modulation on a higher frequency signal) causes some amplifiers to slew or nearly slew as the amplitude of the higher frequency signal is modulated upwards. When an amplifier outputs a higher frequency signal (e.g., carrier signal that is amplitude modulated) that includes conditions of non-slewing, near slewing, and or slewing, the lower frequency signal (e.g., frequency of Gen2) will exhibit phase and or frequency modulation effects. Thus, an amplifier's slewing effects or transient intermodulation distortion under varying high frequency amplitudes results in a frequency or phase modulation effect on a lower frequency signal. Slewing or transient intermodulation distortion occurs (but is not limited

28

to) when one or more stages of an amplifier overloads, approaches clipping/cutoff/saturation, or creates gross distortion, as frequency is increased at the input, or when a fast rise time signal is applied to the input. Thus, an embodiment of the invention is to measure phase or frequency or amplitude modulation of one or more signals other than the signal that is approaching slewing (e.g., approaching its slew rate) or slewing (e.g., output is at the slew rate). For example, suppose an amplifier generates a marked increase in distortion at a particular output level of a signal at frequency of FH (e.g., frequency of FH $>$ 10 KHz, e.g., frequency of FH = 15 KHz). Then a test signal may comprise or include an amplitude modulated signal at 15 KHz and a lower frequency (e.g., $<$ 15 KHz, e.g., 3 KHz) signal added and or an extra higher frequency signal added (e.g., $>$ 15 KHz, e.g., 19 KHz). This example test signal is coupled to an input of the DUT, with the output of the DUT modified to remove the amplitude modulated 15 KHz signal, or to pass through a band of frequencies around the lower frequency signal such as 3 KHz and or around the extra higher frequency signal such as 19 KHz. A phase or frequency or amplitude measurement is done (e.g., via a phase or frequency amplitude detector, or sideband/computational analysis) on the lower frequency signal and or the extra higher frequency signal. The modulation signal has a frequency typically less than the lower frequency signal, which for example may include sinewave(s), sawtooth waveform(s), or other waveform(s).

Thus, an embodiment may include for measuring phase, frequency, and or amplitude modulation effect of one or more signals from a DUT's output, coupling to the input of the DUT a first signal, which is modulated, and a second and or Nth signal whose frequency is different from the frequency of the first signal, coupling the output of the DUT to a modifier to remove a signal related to the first signal, or a modifier to pass one or more frequencies related to the second or Nth signal, and coupling the output of the modifier for measurement of phase, frequency, and or amplitude modulation effect (via the DUT) on the second or Nth signal induced by the first signal or modulated signal.

An embodiment (of the invention) includes coupling to an input of a DUT a first signal that comprises an amplitude modulated carrier signal and a second and/or Nth signal whose frequency is less than or greater than the frequency of the carrier signal, wherein the output of the DUT is modified or filtered to pass one or more frequencies around the frequency of the second or Nth signals, and wherein the modified or filter output is measured for phase, frequency, and or amplitude variation or modulation, induced by the first signal or amplitude modulated carrier. Note the modifier or filter may pass distortion product(s) or signals from the output of the DUT for measurement of phase, frequency, and or amplitude variation modulation induced by the first signal. The modulated signal may be symmetrical or asymmetrical or arbitrary; the output of the DUT (or the modulated signal at the output of the DUT) may be not clipping, clipping on one or more polarity, not slewing, near slewing, and or slew rate limiting in one or more slope (e.g., positive or negative slope), for measurement of phase, frequency, and or amplitude measurements as mentioned above.

In another example, FIG. 20 illustrates measuring phase and or frequency modulation of a modulated signal. For instance, the modifier 26 now removes frequency components related to Gen2 while passing the modulated signal comprised of $f(t)$. If the modulator 131' is an amplitude modulator (with carrier), then 131' would preferably include a limiter amplifier or function prior to coupling into 28' second input, or to the input of 27'. For phase detector 28', a first input

is (now instead) coupled to Gen1' or 21' to allow measuring differential phase (phase modulation) on a modulated signal (or a carrier signal). Similarly 27' allows measuring frequency modulation effect(s) on a modulated waveform (or a carrier signal). For measurement on a scope, preferably, the trigger signal is coupled to Gen2, which is also the signal that causes the phase and or frequency modulation effect on the DUT.

In taking the frequency example above Gen2 may include frequency of 4000 Hz or lower, while $f(t)$, the carrier signal may include a frequency of ≥ 12 KHz. The modulating signal $m(t)$ may include frequency of < 4 KHz. The signals from 131' and Gen2 are coupled to (an input of) DUT 25 (e.g., via summing function or circuit 24) and the output of DUT 25 is coupled to a modifier to remove or attenuate (lower) the frequency related to Gen2 (e.g., remove frequencies at 4000 Hz or lower) while passing the higher frequency signal related to the carrier signal. Preferably, a limiting amplifier is included to remove attenuate amplitude variations prior to coupling to the input of 28' or 27'. Note that 27' generally includes one or more limiting amplifiers for FM detection. For the phase measurement, the phase detector's first input is coupled to 21' or $f(t)$, the carrier signal, while the second input is coupled to the output of modifier 26. Of course, other frequencies may be used for 21', 23', and or 22 in FIG. 20.

Previously, it was mentioned that the modulator 131' may be a phase modulator or frequency modulator. For measurement of (additional) phase and or (additional) frequency modulation effects from a DUT, a preferred method or apparatus would include having a second Wow and Flutter meter or FM detector, and or a second phase detector, both not shown in FIG. 20. Referring to FIG. 20, the second FM detector or second phase detector (e.g., second input) would be coupled to the output 131' (where there is phase or frequency modulation from M'ator). And the first input of the second phase detector would be coupled to Gen1' or Gen2. Phase adjustment block 135 is optional for the second phase detector. In this example, 27' is considered as a first FM detector and 28' is considered as a first phase detector. For 131' having a phase modulated signal, the net differential phase modulation from DUT's output is measured by differentially measuring the outputs of the first and second phase detectors. That is one phase detector coupled to the modulator prior to the DUT and another phase detector coupled to the output of the DUT (via modifier 26) and subtracting the phase detector outputs (from each other to provide a net phase modulation measurement). Similarly, for net frequency modulation measurement, the second FM detector is coupled to 131's wherein the there is frequency modulation from M'ator 131', and the first FM detector 27' is coupled as seen in FIG. 20. The net frequency modulation effect is measured from the DUT via subtracting the output from the two FM detectors (e.g., to provide a net frequency modulation measurement).

Note that net phase and or frequency modulation measurement(s) may include from 131' amplitude modulation. That is, 131' may include phase and amplitude modulation at its output, or frequency and amplitude modulation at its output. Under the example, net phase or net frequency modulation effect(s) from the DUT would be caused by more than one type of modulation (of 131'). The modulation signal for amplitude modulating the FM (frequency modulation) or PM (phase, pulse width, or position modulation) signal may be a separate signal $m_2(t)$ from $m(t)$, or $m_2(t)$ may be related to $m(t)$.

As previously mentioned an embodiment includes measuring phase and or frequency modulation effect(s) of one or

more distortion signals from the DUT. FIG. 21 illustrates an example of measuring the differential phase (or the frequency modulation) of signal or signals from the DUT's output, wherein the frequency or frequencies of the signal(s) include the frequency (frequencies) of the input signal(s) and or one or more distortion (harmonic and or intermodulation) signal from the DUT. Here, up to N tones or signals are coupled to the input of the DUT. The output of the DUT is modified (via modifier 26) to remove or attenuate one or more signals while passing through a selected signal. This selected signal may be of distortion signal based on the N tones. For example, a selected signal may be a harmonic (signal) of Gen1 or Gen2 . . . , or GenN. Another example, a selected signal may be an intermodulation distortion product or signal of Gen1, Gen2 . . . , and or GenN. To measure differential phase of distortion product(s) or signal(s) from DUT 25, one or more input signal generator(s) is coupled to a distortion producing circuit 136 to produce the desired signal for phase detector 28'. For example, if an mth harmonic of Gen2 is produced at the output of DUT 25, the modifier 26 (whose input is coupled to the output of DUT 25) passes through this mth harmonic signal of Gen2 while attenuating one or more other signals from the DUT's output. Distortion producing circuit 136 will take input signal Gen2 and produce the mth harmonic of it and couple this mth harmonic signal (via the generator or input signal) to a first input of phase detector 28' via optional (phase adjusting) block 135. Because input signals or generators are used, the output of 136 or 135 will contain no phase modulation effect and or no frequency modulation effect. The output of modifier 26 then passes the phase and or frequency modulated mth harmonic (e.g., of Gen2) to a second input of the phase detector 28'. The output 28' then provides a differential phase measurement of an mth harmonic of a tone or signal wherein another tone or signal (e.g., one or more input signal(s) or tone(s)) causes the differential phase (variation) or phase modulation.

Similarly when an intermodulation distortion signal is provided by DUT 25, the modifier 26 will selectively pass this intermodulation distortion signal (caused by mixing or non-linearity based on two or more signals or frequencies by the DUT) to the second input of the phase detector 28'. Distortion generator (and filter) 136 will be coupled to the two more signals or tones to produce intermodulation and thus a tone representing substantially the same frequency as the signal out of the modifier 26 (but with no phase or frequency modulation effect for output of 136 or 135). Thus, the output of 28' then provides a measurement for differential phase or phase modulation (from one or more input signals) on one or more intermodulation distortion product or signal from the output of the DUT.

Wow and Flutter meter or FM detector 27' then can be used in measuring frequency modulation effect(s) of harmonic and or intermodulation product(s) or signal(s) from the DUT via modifier 26.

There is an example where a lower frequency signal causes frequency or phase modulation of one or more higher frequency signals (including one or more fundamental frequencies and or harmonic(s)), or intermodulation signals from any combination of input signals at the output of the DUT. For example, Gen1 may be a lower frequency signal of ≤ 1 KHz while Gen2 may be a signal ≥ 4 KHz. The phase modulation effect on the ≥ 4 KHz signal is induced by the ≤ 1 KHz signal. To illustrate, set Gen1 to 600 HZ and Gen2 to 4 KHz. The DUT will output a phase and frequency modulated 4 KHz signal and if the DUT exhibits harmonic distortion, then a multiple of 4 KHz signal(s) will also be phase and or frequency modulated. For each modulated harmonic selected

via the modifying block **25** (to second input of phase detector **28'**), distortion circuit **136** will produce an unmodulated harmonic (via derivation of the distortion product from the input source(s)) for the phase detector's first (e.g., reference) input of **28'**.

Similarly, from the output of DUT **25** (or output of **135**), intermodulation component(s) may appear. These can include signal(s) that comprise of frequencies of the sum and or difference of the frequencies of Gen1 and Gen2 (e.g., in the above example, frequency of Gen1=FL and frequency of Gen2=FH, so intermodulation component(s) can include FH+/-FL, and in general, p(FH)+/-q(FL), where p and q are elements of the integer number system). The DUT **25** will include a phase or frequency modulated version of the intermodulation signal(s), whereas the output of **136** will not include phase or frequency modulation of the intermodulation signal(s). As similarly described above, modifier **26** will pass the selected intermodulation distortion signal to a second input of the phase detector, and the first input of the phase detector will be coupled to **136** for measuring differential phase or phase modulation of one or more intermodulation component or signal from the DUT's output.

In another example of measuring intermodulation more than two signals or generators may be used. For example, two higher frequency signal along with a third lower frequency signal may be used in determining phase modulation effect from a DUT for intermodulation component(s) of the two higher frequency signals (induced phase modulation from the third lower frequency signal).

Similarly, a modulated higher frequency signal and a lower frequency signal may be used to measure phase modulation of a harmonic of a lower frequency signal. Or two or more lower frequency signals and a modulated higher frequency signal may be used to test for phase modulation on intermodulation components of the two or more lower frequency signals, or of any combination of the lower frequency signal(s) and higher frequency signal. Other combinations of input sources or frequencies are possible.

FIG. **21** then allows to test for phase modulation effect from the output of the DUT for (phase modulated) distortion product(s) signal (which is coupled to a second input of a phase detector **28'**). This is done by generating or providing (unmodulated or stable phase) corresponding distortion product(s) signal to a reference or first input to a phase detector **28'**. Optionally, FIG. **21** allows for testing of frequency modulation from the output of the DUT for frequency modulated distortion signals via **27'**.

FIG. **22** is similar as FIG. **21** with generator **138** providing the two or more signals and or modulated signals (via Out1) coupled to the input of DUT **25**. Generator **138** also provides a selected fundamental, harmonic, and or intermodulation frequency signal (via Out2) that is coupled to the reference or first input of a phase detector **28'**. Phase adjustment block **135** is optional to tune the overall phase so that phase detector **28'** is working within a linear region (or is centered) of the phase angle versus voltage transfer function. Generator **138** may be a multiple output signal device that uses frequency synthesis to provide signals to the DUT's input but also synthesizing the corresponding signal(s) to match in frequency for the phase detector (**28'** reference input) so that phase modulation of the fundamental frequency and or distortion products (from DUT **25** via the modifier **26**) can be measured accurately. Thus, a frequency synthesizer may be used in place of blocks **21**, **22**, **23**, **24**, and **136** of FIG. **21**. Generator **138'** may include a phase control, so block **135** may be bypassed.

FIG. **22** also allows testing for frequency modulation effects of the DUT via a frequency synthesizer **138**. The

frequency modulation effect includes frequency modulation of distortion product(s) from the DUT. The output of the modifier **26** is coupled to **27'** for a frequency modulation or Wow and Flutter measurement.

For FIGS. **19**, **20**, **21**, and or **22** the phase adjustment block **135** is optional, as previously mentioned. In another embodiment of the invention a phase shifting circuit or phase adjustment block may be incorporated in the modifier (e.g., **26**) or placed/coupled prior or after the modifier.

FIG. **23** shows a way to measure differential phase via a phase lock loop circuit. This phase lock loop circuit is provided by phase detector **28''**, whose output is coupled to the input of VCO system **139'**. The output of **139'** is a continuous wave signal, which is fed back to In2 of phase detector **28''**. The output of modifier **26** as previously explained, which includes phase modulation from the DUT is coupled to In1 of **28''**. A previous attempt in using this method had a problem that showed rather incorrect results or too low of phase modulation from the DUT. The reason for this problem is that the VCO system **139'** (in the previous attempt) had too much frequency deviation range, which tended to track the incoming phase modulation. It should be noted that In2 of phase detector **28''** should have a stable phase signal (e.g., not a signal that follows the phase modulation of the DUT).

To improve the accuracy of measuring differential phase from DUT **25**, a narrow range VCO (voltage controlled oscillator) system is used in **139'**. Such a narrow range VCO may include a crystal oscillator, ceramic resonator oscillator, or high Q inductor capacitor oscillator with narrow range. (Preferably the narrow range should be in the area of <0.5% of the oscillation frequency.) This implies that the input generators' frequency that is passed through the modifier **26** must be very stable (e.g., crystal controlled) as well and should exhibit low phase noise. Also, preferably, the VCO control voltage while the PLL circuit of **28''** and **139'** is locked should be low in AC voltage as to not track (or track minimally) the DUT's output signal phase modulation. The output of the phase detector PDO is then coupled to a suitable filter (e.g., usually of wider bandwidth than the filter used in the VCO System, **139'**, to provide a signal via PDO substantially indicative of the induced phase modulation) to attenuate frequencies related to the input of the phase detector (In1 and or In2). Because in the specific case of audio testing, a low frequency VCO may include a higher frequency narrow range (e.g., low phase noise) voltage controlled oscillator followed by a suitable frequency counter or divider (e.g., a frequency divider output is coupled to the input In2 of **28''**).

Two or more serially coupled phase lock loop circuits may be used to provide improved average phase, which would be used in measuring the phase modulation effect on a DUT. For example, a phase lock loop comprises of an input (usually coupled to a phase detector' input) and an output (usually the output of an oscillator or an output of a counter whose input is coupled to the oscillator's output).

One embodiment of the invention would include coupling two or more phase lock loop circuits in series or cascade. The input of the first phase lock loop circuit would be coupled (via modifier **26**) to the DUT. The output of the final phase lock loop would be coupled to a first or reference input of a (separate) phase detector while the second or other input of the (separate) phase detector is coupled to the output of the DUT (e.g., via a modifier **26**). The output of the (separate) phase detector is then coupled via a filter to a meter or oscilloscope for measurement of phase modulation effect on the DUT.

In an alternate example, the phase lock loop system with PDO may be substituted for **28'** in FIGS. **19**, **20**, **21**, and or **22** (where block **135** or **136** is not needed).

It should be noted (however) that the method or apparatus as shown in FIGS. 19, 20, 21, and or 22 has (substantially) the highest accuracy because a derived input signal is coupled to the first or reference input of the phase detector. (Preferably FIGS. 19, 20, 21, and or 22 include a DUT that does not change the frequency of the input signal such as amplifiers, speakers, microphones).

Phase adjustment block 135 in any of these figures may include an all pass phase shifter, a filter (e.g., low pass, high pass, and or band pass), and or a regeneration oscillator. Phase adjustment block 135 can be used as a calibrating tool for the phase measurement. For example block 135 can switch in (a phase lead or phase lag of) a phase shift angle of “x” degrees, in which the phase detector will show a corresponding voltage or signal. For instance, a change in “x” degrees via block 135 will yield “y” volts change in output of the phase detector (e.g., 28’).

It should be noted that (Ref In of) an input of phase detector 28’ in FIG. 19, 20, 22, and or 22 may be coupled to the input generator(s) such as Gen1, Gen2, and or GenN (or other signal sources) via summing or combining circuit 24 or via the input of the DUT 25. A phase adjustment block 135 and or filter may be included in (between) the coupling of the output of summing circuit 24 to an input to phase detector 28’.

FIGS. 19, 20, 21, and or 22 are examples of the previously mentioned passage (paragraph [0017] of US 2007/0069737 A1) of the invention pertaining to measuring (small) variation(s) in the phase (or frequency) response of a DUT with a dynamic biasing signal (e.g., lower frequency signal) to provide the variation(s) of phase (e.g., of a higher frequency signal). And the phase response is sometimes defined as the measured phase angle of the output minus the phase angle of the input of the DUT. Thus, measuring a variation of the phase response refers to phase variations of the output of the DUT as compared to phase of the input of the DUT (by definition the phase angle to the input is usually considered as zero degrees).

FIG. 23 with a narrow range (band) VCO has an additional advantage of measuring phase modulation because the DUT, which may (or may not) have a slight change in frequency at the DUT output. A DUT such as (digital) recorder at playback or a digital processor may output a slight change in frequency at its output (versus the input frequency).

In an embodiment (of the invention), while the selection of a waveform may be sinusoidal for the signal that causes the phase or frequency modulation effect on a DUT, a non sinusoidal waveform can be used (e.g., for FIGS. 3, 19, 20, 21, 22, and or 23). A waveform including one or more ramp(s) can be used, for instance. For example a linear function signal such as a simple sawtooth waveform (or triangle wave) may be used for the lower frequency signal (or the modulating signal, e.g., $m(t)$) that induces phase or frequency modulation effect on a DUT. Linear function signals (e.g., $y=mx+b$) can be used to map out a phase versus voltage transfer function. This transfer function can be decomposed in polynomial form (or power series analysis) to determine (or predict) the linear term and distortion products of phase modulation for a sinusoidal waveform when substituted in place of the linear function signal. By taking the derivative of the power series (or polynomial), the frequency modulation effect can be decomposed into a linear term plus distortion products for a sinusoidal signal instead of the linear function signal.

Note that frequency deviation (modulation) is proportional to the phase (angle) shift modulation times the frequency of the signal causing the phase modulation. So determining the

range of phase shift over the voltage range at the output of the DUT may be sufficient in predicting the frequency modulation effect of the DUT.

For example, in the previous embodiments involving a low frequency signal inducing frequency modulation on a higher frequency signal (as measured from the output of the DUT), increasing the frequency of the low frequency signal results in a proportional increase in induced frequency modulation e.g., frequency deviation of the higher frequency signal.

In one example of FIG. 19, the lower frequency generator signal is a sawtooth waveform, and the higher frequency generator signal is a sinusoid. Other combinations are possible.

For example “complex” sawtooth waveform may include of two or more positive (or negative) slope segments (and or curve) to form a piecewise signal. A first or second or “N” slope segment may be used to reveal crossover distortion effect near the zero crossing of the DUT. In this example, a ramp may have a greater (steeper) slope at outside a crossover distortion region, and a smaller (shallower) slope ramp may pass through the crossover distortion region. And a suitable higher frequency signal is added to this “complex” sawtooth waveform to measure the phase and frequency modulation effect. In this example the “complex” ramp allows closer scrutiny of phase or frequency modulation effects of a DUT into the crossover distortion region.

Another embodiment (of the invention) includes measuring multiple signals at the output of the DUT for phase and or frequency modulation. For example, using a second (or N) modifier coupled to the DUT and another set of phase and or frequency detectors, one can measure how a high frequency signal (e.g., modulated carrier) induces phase and or frequency modulation on a lower frequency signal and how a lower frequency signal induces phase and or frequency modulation on a higher frequency signal (e.g., modulated or unmodulated carrier). A simultaneous measurement of both effects may reveal an interaction of transient and or steady state phase and or frequency modulation of how the signals affect each other. For example, a modulated higher frequency signal may induce (phase or frequency) modulation on the lower frequency signal, while the lower frequency signal is inducing (phase or frequency) modulation of the higher frequency signal. The effect of the modulated higher frequency signal may cause an increased effect of phase modulation on itself. That is when two or more signals are phase or frequency modulating each other, there may be a “reflecting” or interactive effect on each signal. This embodiment may include modulating both or either (e.g., lower frequency and or higher frequency) signal(s) and measuring the phase and or frequency modulation from two or more phase and or frequency detectors (via filters and or limiting amplifier or equivalent, and or spectrum analysis or a spectrum analysis system, see below).

For example for an amplitude modulated signal comprised of, (one or two or more) signals in the general form of $S1(t)=[1+m1(t)] \sin [(2\pi F1)t]$, and or $S2(t)=[1+m2(t)] \sin [(2\pi F2)t]$. $S1(t)+S2(t)$ are coupled to a DUT, the output of the DUT is measured for phase modulation of signals around F1 and or F2. And for example, $F2>F1$ in frequency and $m2(t)$ may be a lower frequency (sinusoid) waveform of frequency lower than F2 or F1. The modulating signal $m1(t)$ may be a step function including $u(t-td)$ or $u(t-td)\times g(t)$, where td is a delay time and $g(t)$ is a waveform function. Alternatively $m1(t)$ may be a pulse waveform or filtered (e.g., low pass filtered) pulse waveform, wherein the pulse waveform may include a rectangular pulse or squarewave. Because $m2(t)$ will induce phase and frequency modulation effect on a signal

around frequency F1 at the output of the DUT, by enabling m1(t) to increase the amplitude of a signal around frequency F1, the phase or frequency of the signal around F2 will shift. Because the carrier frequency F2 has shifted in phase or frequency due to the (abrupt) increase in amplitude of sin [(2piF1)t], it may be possible to measure a (slight) change in phase or frequency on a signal of frequency (around) F1 at the output of the DUT. This example shows that an increase in (amplitude) modulation at frequency F1 can result in a subsequent shift or variation in phase or frequency for F1. Other type or combination of modulation is possible for m1(t) and or m2(t), which include any combination of: Frequency Modulation, Amplitude Modulation, Position Modulation, Pulse-Width Modulation, Phase Modulation, and or no or negligible modulation (e.g., continuous wave). The DUT is not limited to two signals, and at least two modulated/unmodulated signals may be coupled to an input to the DUT for measurement of phase and or frequency modulation effect at the output of the DUT. For example, m1(t) may include phase or frequency modulation, while m2(t) may be a fixed constant. Then when S1(t) and S2(t) are coupled to an input of a DUT, the output of the DUT will show frequency modulation effect of a signal around F2 that is being phase or frequency modulated one step further.

As mentioned before, the DUT may be an analog and or digital device. It should be noted at low levels some digital devices show a marked increase in distortion, so measuring for phase and or frequency modulation effects fundamental frequency and or distortion products is relevant.

It should be noted that computational analysis of the sidebands may be substituted to a phase or frequency detector for an alternative to measuring any of the frequency or phase modulated signals from the DUT (e.g., that is induced/caused by a lower or higher frequency signal). Sideband analysis was previously mentioned in US 2007/0069739 A1, published on Mar. 29, 2007 in paragraph [0050]. One embodiment of the invention includes Fourier Analysis (e.g., Fourier or spectrum analysis includes FFT, DFT, DTFT, DCT, Fourier Transform, Fourier Series, Discrete Fourier Series, using a spectrum or waveform analyzer, filter, tuned or tunable/variable frequency filter, and or the like) to analyze one or more sideband signals around a signal whose spectrum is around FH and or FL (or distortion product(s)) out of the DUT. By calculating the energy or power of the sidebands, a calculated frequency deviation is provided.

For example, U.S. Pat. No. 5,818,240 by Cabot (incorporated by reference) shows in column 9 line 30 that Wow and Flutter or frequency deviation may be calculated as the addition of upper and lower sideband signals squared summed over N number of sideband pairs and then taking the square root of the squared sums (Wow and Flutter or frequency deviation=square root [(LSB1+USB1)²+ . . . (LSBn+USBn)²], where LSB is the Lower Sideband, USB is the Upper Sideband, n=number of sideband pairs, and ² represents raised to the second power.)

Another embodiment of the invention includes using sideband analysis (e.g., using a spectrum analysis system) to determine phase or frequency modulation effects from one or more signals from the DUT, to preferably use/couple a filter or band pass filter from the DUT's output, and couple the output of the filter or band pass filter to a limiting amplifier's input, and then perform Fourier/spectrum analysis or couple to a spectrum or waveform analyzer. The limiting amplifier (or limiter, comparator circuit, or zero crossing circuit) removes amplitude modulation sidebands to reveal any frequency or phase modulation sidebands. The output of the limiting amplifier then is coupled to a spectrum analyzer or to

Fourier or spectrum analysis (system) for sideband analysis. Generally, the greater the amplitude and or number of sidebands from the limiting amplifier's output reveal in some proportion, a greater amount of phase and or frequency deviation (e.g., frequency deviation=square root [(LSB1+USB1)²+ . . . (LSBn+USBn)²], where LSB is the Lower Sideband, USB is the Upper Sideband, n=number of sideband pairs, and ² represents raised to the second power.). The filter may pass through with sufficient bandwidth (for sidebands) around FL and or FH, any distortion products from the output of the DUT. The limiting amplifier, zero crossing circuit, modifier/filter, and or Fourier or Spectrum analysis, may be implemented with analog and or digital circuits, computer, and or Digital Signal Processing (DSP).

An example filter or bandpass filter is denoted by Modifier 26 or 26A (in FIG. 3,11,14,16,19,20,21,22, or 23), or any of 31-36 or 41 (of FIGS. 4A-4F, or FIG. 5) which would be coupled to a limiting amplifier (or equivalent) such as 121, 126, or 126A in FIG. 17.

The filter or bandpass filter may be implemented by a digital and or analog filter. The limiting amplifier may be implemented by a Sgn(x) function, which for example has Sgn(x)=1 for x>0 and Sgn(x)=-1 for x<0. The limiting amplifier or comparator or Sgn(x) function serves as a zero crossing detector of the signal that is to be measured for phase or frequency modulation effect. Thus, an embodiment of the invention includes: Coupling two or more signals into a DUT's input, wherein the output of the DUT is modified by a filter or bandpass filter, and wherein the output of the filter or bandpass filter is coupled to an AM component removing circuit or function/circuit comprising a limiting amplifier, zero crossing detector, Sgn(x) function, or the like, and whereby the output of the AM component removing circuit or function is analyzed for sidebands to determine phase or frequency modulation of one or more signals from the DUT.

Analysis of sidebands and or carrier, spectrum analysis, or a spectrum analysis system may include any of the following: FFT (Fast Fourier Transform), FT (Fourier Transform), DFT (Discrete Fourier Transform) DTFT (Discrete Time Fourier Transform), Short Time Fourier Transform, Fourier Series, Discrete Fourier Series, Cosine Transform, Discrete Cosine Transform, filter, tuned filter, tunable/variable frequency filter, and or a spectrum or wave analyzer.

Filtering or modifying method or apparatus may include analog and or digital filter(s) or modifying function(s).

One or more software programs (and or storage of data) may be included in the invention. For example, software defined filter(s) or modifying function(s) may be included as part of an embodiment of any of the inventions mentioned.

As mentioned previously, an embodiment of the invention may include measuring frequency response at different offsets of a device. For example, add an offset voltage for each frequency response measurement. For instance, such as adding one or more DC voltages (Note: normally devices are measured for frequency with a zero offset voltage) with a swept frequency signal (e.g., two or more discrete tone bursts and or continuous sweeping in frequency) to measure a dynamic frequency response.

In some devices, adding a DC offset signal is not possible because of DC blocking in the device (e.g., capacitor or transformer in a signal path of an amplifier or device). Thus, one embodiment of measuring dynamic frequency response of a system or DUT is to add a lower frequency signal with a set of high frequency signals and measure the high frequency signal's amplitude (and or phase response) as a function of the lower frequency signal voltage or current. The lower frequency signal may include a stair step, ramp, sinusoidal,

sawtooth, or arbitrary waveform. The set of higher frequency signals may include one or more tone bursts (e.g., multiburst), or a swept or varied frequency waveform/signal. In one embodiment of the invention, a ramp, sinusoidal, or stair step waveform is provided as the lower frequency signal, and a continuous wave signal such as a higher frequency sine wave signal that is varied over time is provided as the higher frequency signal. The lower frequency signal and the higher frequency signal are coupled to an input of the DUT, and the output of the DUT is measured for amplitude and or phase of the higher frequency signal (typically for two or more higher frequencies). Generally, the lower frequency signal nearly spans the range of the DUT's output range, or can be narrower in range (e.g., to examine dynamic frequency near the cross over distortion region of an amplifier, or quantizing distortion (range) of a digital system).

For example, a 100 Hz signal (e.g., sinewave) is summed with a signal source whose frequency can be in the range of 1 KHz to 20 KHz. Typically the lower frequency signal is set to an amplitude to span most of the voltage range of an amplifier and the higher frequency signals are lower in amplitude of the lower frequency signal. The DUT is measured at the output of the higher frequency signal (via a spectrum analyzer or voltmeter/oscilloscope/display with a modifier or filter to remove the lower frequency signal) at two or more high frequency signals. For example, a 100 Hz signal plus a 10 KHz signal is supplied to the input of the DUT with a first measurement for amplitude at 10 KHz as a function of the 100 Hz signal at the output of the DUT, and a 100 Hz signal plus a 20 KHz signal supplied to the input of the DUT with a first measurement for amplitude at 20 KHz as a function of the 100 Hz signal at the output of the DUT. The higher frequency signal may be swept, and or the lower frequency signal's amplitude is generally larger or much larger than the higher frequency signal or swept signal.

Measurement of the dynamic frequency response for a device, for example, is useful in measuring stability, phase, and or gain margin of a feedback system in a dynamic manner. For example, there are amplifiers that show very good stability and phase margin with a signal applied without offset. However, instability or peaking in (a small signal) frequency response may occur when the amplifier is near or below its maximum output range (e.g., frequency response of an AC signal when an amplifier is at an offset or temporary offset close to the maximum output range.) A lower frequency signal whose amplitude is larger or much larger than the higher frequency signal used for (dynamic) frequency response measurement, may be considered as a dynamic biasing signal.

An alternative method or apparatus to measure dynamic frequency response is to generate a lower frequency signal such as a stair step signal (or ramp signal, such as a nonlinear or linear ramp). For example, two or more (stair) steps or levels of the lower frequency signal include a combination of the following: two or more test tones (e.g., one or more tones may include a sine, pulse, squarewave, arbitrary waveform of one or more frequency, where in the two or more test tones are in sequence and or in partial or whole adding together), one or more pulse waveform (e.g., pulse waveform may include rectangular, Gaussian, sine squared, triangular), squarewave, or higher frequency signal (or may include a swept frequency signal). The lower frequency signal with signals in two or more levels or steps is coupled to an input of a DUT. The output of the DUT is measured for frequency or pulse response (e.g. pulse response may include amplitude change, ringing, overshoot, undershoot, tilt, roll off on one or more corners of the pulse), and or amplitude (and or phase) of the

higher frequency signal included for two or more steps or levels. In some cases a stair step signal may be replaced with an arbitrary signal (e.g., a ramp waveform, sinewave, triangle wave, etc.), and or the higher frequency signal may include a frequency modulated or swept frequency signal.

In one embodiment (of the invention), the output of the DUT is coupled to a filter or modifier to remove or reduce the amplitude of the lower frequency signal, while passing substantially the swept or higher frequency signal (e.g., for frequency response measurement).

In another embodiment (of the invention), the higher frequency signal may include a modulated signal at two or more steps or levels of the lower frequency signal. A modulated signal may include an amplitude modulated signal provided in two or more steps or levels of a lower frequency signal, which is then coupled to an input of a DUT. An output of the DUT is measured (or examined) for envelope distortion or for extra sideband (e.g., using a Short Time Fourier Transform or spectrum analysis), envelope asymmetry, and or phase or frequency modulation of the carrier of the amplitude modulated signal on one or more levels or steps of the lower frequency signal.

For example, a lower frequency signal may include a ramp signal, a sinewave, triangle wave, or stair stepped signal. A higher frequency signal is applied to all or part of the low frequency signal to form a test signal to an input of the DUT. Generally, the lower frequency has a greater amplitude than the higher frequency signal. The output of the DUT is then coupled to a display (e.g., oscilloscope) or amplitude detector to show or measure the amplitude of one or more cycles of the higher frequency signal as function of the output range of the DUT. Generally, the frequency of the higher frequency signal is changed or varied. For example, the lower frequency signal is a triangle wave generator or source, and the higher frequency signal is a sine wave to form the test signal into the DUT. The output of the DUT may show greater amplitude of the higher frequency in one part of the triangle waveform than another location of the triangle waveform (e.g., the negative peak of the triangle waveform shows a boost in high frequency response versus in the positive peak portion of the triangle waveform). Increasing, decreasing, or varying the frequency of the higher frequency signal may then show more clearly differences in frequency response at different portion of the lower frequency waveform (e.g., triangle waveform), which for example, shows a frequency response in a localized portion of an output span of the output of the device.

Another embodiment (of the invention) is to provide an amplitude modulated waveform that is coupled to an input of the DUT and wherein the output of the DUT is measured for envelope distortion (e.g., including a partial rectification effect) phase and or frequency modulation on the carrier of the amplitude modulated signal. Phase and or frequency detectors, or spectrum analysis (system) previously mentioned may be used for the measurement of phase and or frequency variation or modulation of the carrier of the amplitude modulated (carrier) signal at the output of the DUT. For example, (the envelope distortion of) the amplitude modulated (carrier) signal at the output of the DUT is coupled to a (filter and) limiter or AM removal circuit or equivalent (e.g., Sgn(x) function, zero crossing detector, comparator, limiting amplifier), and the output of the limiter is then coupled to a phase and or frequency measurement system such as a phase or frequency detector or sideband analyzer (or spectrum analysis system) to measure phase or frequency variation on the carrier of a modulated signal. An amplifier that exhibits slewing or other distortions could be included at a DUT. Typically the amplitude modulation is less than 100% or

equivalently the carrier is modulated such that the carrier is not pinched off (e.g., the amplitude modulated signal includes a carrier with) residual carrier).

Alternatively, a second signal, different in frequency of the carrier, may be added to the amplitude modulated signal for a test signal. This test signal is then coupled to an input of a DUT, and the output of the DUT is coupled to a modifier or filter to remove/attenuate the second signal. The output of the modifier or filter then is coupled to limiter or equivalent amplitude modulation removing function, and the output of the limiter or amplitude modulation removing function measured for phase and or frequency variation of a modulated signal from the output of the DUT.

Yet another embodiment (of the invention) is to couple an amplitude modulated signal into an input of a device (e.g., audio device), and couple an output of the device to a spectrum analysis system to measure extra sidebands (e.g., beyond the first set of sidebands near the carrier of the amplitude modulated signal) to provide measuring distortion of the amplitude modulated signal from the output of the (audio) device.

In terms of measuring phase and frequency modulation effect(s) from the output of a device, the use of modulated sources can be implemented in at least three methods.

As previously stated a modulated higher frequency signal combined with a lower frequency signal coupled to the input of a device, causes the device to output an induced phase and or frequency modulation effect on the lower frequency signal.

In another (embodiment of the invention), a modulated lower frequency signal (AM, PM, and or FM) combined with a higher frequency signal is coupled to an input of the DUT. The output of the DUT is then measured for phase and or frequency modulated effect(s) on the higher frequency signal.

Yet another embodiment (of the invention) involves providing two (or more) modulated signals of different frequencies, which are coupled to an input of the device, and wherein the output of the device is measured for a phase and or frequency variation (or modulation), induced by one or the other (or both) modulated signal. For example, both modulated signals may start with amplitude modulation into the input of the device, the output of the device is then measured for phase and or frequency modulation of each carrier of the amplitude modulated signals from the output of the device. Later, at least one of the carrier signal(s) may be varied in phase or frequency for measurement of phase and or frequency variation on the other carrier signal.

Measurement of phase or frequency variation for a signal at the output of the device may include a modifier and phase or frequency detector, or Wow and Flutter meter, or by spectrum (sideband) analysis (system).

In the previously mentioned amplitude modulated signals, the carrier and or modulating source may be static or changing in frequency.

An embodiment (of the invention) includes the use of computation (such as computing a Fourier Transform). A STFT or DFT (Short Time Fourier Transform or Discrete Fourier Transform) or spectrum analysis may be used or computed for analyzing (transient) distortion at a localized portion of the DUT's transfer function. For example, a DUT may exhibit crossover or quantizing distortion. With one or more sinusoidal waveform (which may be modulated) added to a dynamic biasing signal (e.g., a lower frequency signal than any of the sinusoidal waveforms, wherein the dynamic biasing signal spans at least a portion of the output range of the DUT) and coupled to an input of a DUT, harmonic distortion, intermodulation distortion, modulation/envelope distortion, dynamic phase or frequency variation (or modulation), or

other forms of distortions can be measured, computed, or displayed for a localized region of the output range of the (output of the) DUT. In the crossover distortion example, distortion measured near or within the crossover distortion region (e.g., around zero in some amplifiers) will be higher than distortion outside the crossover region.

In terms of testing for phase and or frequency modulation effect on a DUT, a testing method or apparatus utilizes multiple frequencies applied to a device under test for measuring newly discovered frequency modulation effects. An embodiment may include a lower frequency signal with a smaller amplitude higher frequency signal to test a dynamic change in frequency response, gain, frequency, and or phase. This dynamic test can reveal frequency modulation effects. Another embodiment may include the use of a multiple frequency signal to dynamically induce a time varying phase or frequency distortion for the device that has differential phase distortion. The device's output is then measured for FM or PM effects. For example, measuring is done with an FM or phase detector or computational analysis to measure shift in one of the frequencies used in the test signal or to measure frequency modulation effects of any signals, including distortion products, from the device (or system). Yet another embodiment of the invention may include biasing a device with a voltage to span the output voltage range of the device while measuring harmonic or intermodulation distortion or phase or frequency response at the various operating points.

Also as stated previously (or stated afterwards), any modulated signal may include finite, negligible, and or zero modulation.

In testing for harmonic or intermodulation distortion of a multiple channel system such as two or more channels, often testing is done with a single channel or two or more channels driven simultaneously with a signal of the same frequency. However, because often the multiple channel system shares a common power supply, other types of distortions are hidden when the same frequency signals are applied to both or multiple channels. Therefore yet another embodiment of the invention is to provide a first channel of first signal (e.g., of a first frequency) and a second channel of second signal (e.g., of a second frequency), wherein the first and second signals are substantially not the same. For example, a first signal may be modulated whereas the second signal is modulated, or a first signal has frequency of F_x , and the second signal has a frequency of F_y , where F_x is not equal to F_y . In another example, a first signal may include a signal including one or more frequencies, and a second signal may include a signal include one or more frequencies, wherein at least one frequency is different, dissimilar, or not equal in the first and second signals.

An (example) embodiment would include coupling dissimilar signals to the inputs at two or more channels of the system (e.g., amplifier, processor, etc.) and measuring for distortion (harmonic, intermodulation, phase modulation, and or frequency modulation) effect(s) caused by the signal of the other channel. For example, a low frequency (F_{low}) signal may be applied to the input of Channel A for an output voltage or power level on Channel A of a multiple channel (e.g., stereo) amplifier. And, a differential phase or frequency modulation test signal (e.g., signals of FL and FH, see any of the FIGS. 7A-9B) may be coupled to the other channel such as Channel B. The output of Channel B will exhibit phase and or frequency modulation effect as a function of frequency FL (or a modulated (e.g., amplitude modulation) signal frequency for "carrier" frequency FH) that is (further) varied or modulated by the Channel A signal related to frequency F_{low} . In a related example or embodiment, power supply

ripple, and or power supply voltage variation caused by any combination of ripple and or loading effect on the power supply by one or more channels of a system, can induce one or more (extra) phase or frequency modulation effects on the channel that is coupled to the differential phase or frequency modulation test signal.

Similarly, intermodulation and or harmonic distortion measured on one channel may have modulated intermodulation and or harmonic distortion product(s) that is induced by another channel or by power supply ripple. For example, power supply rejection on a system in feedback systems generally is proportional to the amount of feedback and open loop gain. The higher the open loop gain with feedback the greater the power supply rejection that occurs, and less voltage variation from the power supply is coupled to the output of the feedback system. However, some systems include circuits or functions that include crossover distortion, which causes a significant drop in open loop gain for the feedback system. So at or near the crossover distortion region, the power supply rejection is much poorer when compared to power supply rejection outside the crossover distortion region(s). Thus, distortion components near or at the crossover region are generally high in amplitude, which can be further varied in phase and or amplitude induced by power supply voltage variation. Again, power supply voltage variation is caused by any of the channels having a loading effect on the power supply and or power supply ripple. A varying voltage in the power supply for the system or amplifier generally induces at least a small amount in gain variation in one or more stages of the system or amplifier. This gain variation induces a change in distortion (amplitude and or phase) at the system's output and a change in phase or amplitude for one or more signals at the output of the (feedback) system.

Thus, an embodiment (of the invention) includes a method for testing for distortion in a multiple channel system or amplifier. This includes coupling a first signal to a first channel of the system or amplifier, and coupling a second signal to a second channel of the system or amplifier. Wherein the first signal is different from the second signal, and wherein harmonic, intermodulation, (differential) phase modulation, frequency modulation, and or differential gain effect or distortion is measured from the first channel includes an induced effect (e.g., modulation) of one or more signals or frequencies from the second channel is included.

The system may include crossover distortion or a crossover distortion region. A signal from the output of the system that is located near or in a portion of the crossover distortion region may be affected in the following manner. A variation in the power supply, or a voltage variation of the power supply induced by one or more channels operating induces/provides a variation of harmonic distortion, intermodulation distortion, phase modulation, frequency modulation, and or differential gain distortion in or near the crossover distortion region.

Differential gain (as an embodiment of the invention) may be measured by providing a low frequency signal and higher frequency signal coupled to an input of a system (e.g., audio system). Wherein the higher frequency signal is measured in amplitude over a span of output range of the system (e.g., the low frequency signal is modified or removed or attenuated at the output of the system) or measured as a function over time. For example, a higher frequency signal may be above the known higher frequencies, 6000 Hz or 7000 Hz, used in SMPTE IM test (two sinusoidal waveforms, a low frequency signal at 60 Hz or 70 Hz, and a higher frequency signal at 6000 Hz or 7000 Hz), or standard intermodulation distortion test signals. In particular, a higher frequency signal set >7000

Hz (e.g., 10 KHz to 20 KHz) with a lower frequency signal (for audio systems) is suitable for revealing more types of distortions in a system.

As an example, a lower frequency signal may include a signal above 400 Hz or a signal whose frequency is less than 7000 Hz. Typically, the lower frequency signal includes a linear portion such as a waveform of a ramp, triangle wave, stair step, stepped, and or sawtooth waveform. The lower frequency waveform (e.g., of any frequency) may include a sinusoid waveform, non-sinusoid waveform, ramp waveform, stepped waveform, and or an arbitrary waveform.

In terms of an improvement in the current SMPTE IM testing methods, an embodiment of the invention may include providing >7000 Hz as the higher frequency signal plus a lower frequency signal to measure intermodulation distortion. For example, a higher frequency signal in a range of 10 KHz to 20 KHz provides improved measurement for intermodulation distortion for a system or amplifier. The lower frequency signal may be a signal whose frequency is equal or less than 7000 Hz. In the SMPTE IM test, the lower frequency signal has been 60 Hz or 70 Hz. And in another SMPTE IM test, the lower frequency is 400 Hz (with 4000 Hz for the higher frequency signal). An embodiment of the invention can include a lower frequency of greater than 60 Hz, 70 Hz, or 400 Hz. For example, the inventor had observed that phase modulation in some systems actually increase (or in another system, the phase modulation decreases) with raising the lower frequency signal, which implies intermodulation distortion around the higher frequency signal would increase (or decrease) if the lower frequency signal is raised in frequency.

Alternatively, as an embodiment (of the invention), differential gain may be measured by: providing a low to mid frequency signal and a modulated (e.g., amplitude, phase, and or frequency modulation) signal. The modulated signal typically has a carrier frequency that is higher than the low to mid frequency signal to an input of a system (e.g., an audio or RF system). And wherein the modulation frequency is typically lower than the frequency of the low to mid frequency signal. The amplitude of the low to mid frequency signal is measured (e.g., over time) via an output of the system.

Yet another embodiment of the invention is to measure one or more distortion effect using a modulated carrier waveform (e.g., differential phase and or frequency modulation distortion). The modulated waveform is coupled to an input of a system (e.g., audio system, amplifier, and or processor). The output of the system is measured for distortion products (e.g., harmonic and or intermodulation), extra sideband distortion product(s), (extra) phase modulation of the carrier, and or (extra) frequency modulation of the carrier. For example, an amplitude modulated signal is coupled to an input of a system. The output of the system is analyzed/measured for one or more extra sidebands related to the carrier of the amplitude modulated signal. The output of the system (DUT) may be analyzed/measured for distortion products including intermodulation, harmonic, differential phase, frequency modulation, and or signal(s) whose frequency is related to the modulation frequency or harmonic(s) of the modulation frequency. The output of the system may be analyzed/measured for phase and or frequency modulation of one or more of the following: The carrier of the modulated signal, any distortion products at the output of the system, signal(s) related to the modulation frequency or harmonic(s) of the modulation frequency. Phase and or frequency modulation measurement technique(s) may include any of the previously mentioned methods such as using in any combination: a phase detector, amplitude modulation removal/reducing circuit, limiter, fil-

ter, modifier, synchronous detection, frequency detector/discriminator, phase lock loop circuit, $\text{Sgn}(x)$ or $\text{Sgn}(t)$ function, and or spectrum analysis.

For example, an amplitude modulated signal or an AM signal (e.g., wherein the modulation percentage is <100%, leaving a residual carrier, or wherein the modulation percentage equal or greater than 100%) is coupled to an input of an audio system or amplifier. The output of the audio system or amplifier is coupled to a phase detector and or frequency to voltage converter (or frequency detector) to measure a phase and or a frequency modulation effect of the carrier. The output of the phase or frequency detector provides a signal indicative of a phase or frequency modulation effect (e.g., of the carrier) from the output of the audio system or amplifier. It should be noted that spectrum analysis may be used to measure phase and or frequency modulation. It was observed experimentally that a phase and or a frequency modulation effect (e.g., of the carrier of the AM signal) does indeed exist in an audio amplifier when an AM signal is used as a test signal (AKA Quan effect #4). This AM test signal allows measuring (unwanted) phase and or frequency variation of the AM (test) signal. Real world signals such as musical notes or phrases are raised in level or lowered in level (e.g. amplitude modulated) wherein when music is amplified (via a DUT), phase and or frequency modulation can occur in the musical notes or phrases.

A second signal may be combined with the AM signal, which is then coupled to a system or amplifier. At the output of the system or amplifier, one or more distortion product such as harmonic, intermodulation, and or cross modulation is measured. Generally, cross modulation distortion is tested in RF systems, but is reapplied to audio systems because of the changing in loudness of one part of music while another part of the music is not changing in loudness (e.g., in the same manner). The second signal may be a static amplitude signal, which at the output of the system or amplifier, cross modulation is measured. Cross modulation distortion in a (static or constant amplitude) signal is related to the amount of amplitude modulation induced by an AM signal to a static amplitude signal. The output of the system may be measured for phase and or frequency modulation on the AM signal, the second signal (e.g., an originally static amplitude signal), and or any distortion signal (e.g., one or more frequency translated version of the AM signal, harmonic and or intermodulation distortion signal related to the AM signal and the second signal).

Another embodiment (of the invention) may include two or more modulated signals coupled to an input of a system or amplifier. The output of the system or amplifier may be measured for harmonic distortion, intermodulation distortion, cross modulation distortion (e.g., onto each other modulated signal), phase variation on any signal (via the output of the system or amplifier), and or frequency variation on any signal (via the output of the system or amplifier). For an example of modulated signals, two or more AM signals may be applied or coupled to an input of a system or amplifier. Any modulated signal may be amplitude, frequency, phase, and or pulse modulated (e.g., in time succession and or in a simultaneous manner). The amount of modulation may be zero and or finite (e.g., on any of the two or more modulated signals coupled to the input of the system or amplifier).

It should be noted that a low frequency signal, or a modulating signal (e.g., for modulating any carrier signal), may include one or more (or a plurality) of the following: a sinusoidal waveform, a ramp signal, a sawtooth signal, a triangle waveform, a step or staircase waveform, and or an arbitrary signal.

Another embodiment (of the invention) includes a sampled or gated phase detector in FIG. 23, block 28', to measure induced phase modulation from a DUT. To avoid tracking the phase modulation from the output of the DUT to the VCO System 139' by use of a continuous phase detection circuit, a sampled or gated or sample and hold type phase detector may instead be used. The sampling or gating signal may be derived from the lower frequency signal that is coupled to the input of the DUT. Or the sampling or gating signal is provided by filtering/modifying the output of the DUT to pass the lower frequency signal. A sampling, gating, or timing signal is then provided or derived for the gated or sampled phase detector circuit. For example, the PDO signal may be coupled via a sampling or gating circuit to Vco in of 139'. Sampling or gating the Vco avoids tracking the induced phase modulation shifts from the DUT.

Thus, an embodiment (for example see FIG. 23) includes providing two or more signals coupled into an input to a DUT, and further comprises coupling an output of the DUT to a modifier. The modifier passes a signal of a selected frequency or frequency band that is coupled to a phase lock loop circuit. The phase lock loop circuit includes a voltage controlled oscillator that is coupled to a sampled or gated signal from a first phase detector output signal (e.g., this sampled or gated signal is an added characteristic of 28" or a sampling or gating circuit is inserted or added between the output of 28" and input of VCO 139'). The first phase detector outputs (via a filter) a signal to provide a signal indicative of induced phase modulation from the DUT. Should the first phase detector in the phase lock loop circuit include a gated output or input circuitry, then a second phase detector is included. A first input of the second phase detector is coupled to the output of the Vco and a second input of the second phase detector is coupled to the output of the modifier (e.g., block 26). The output (e.g., via a filter) of the second phase detector provides a signal indicative of the induced phase modulation from the DUT.

An alternative to a phase lock loop circuit, to provide a substantially stable phase signal source to measure induced phase modulation (e.g., differential phase) from the DUT, includes coupling a narrow band filter to the output of the DUT to "flywheel" or average out the induced phase modulation. For example, a crystal or crystal filter may be coupled to the output of the DUT to provide a stable phase signal that is substantially the average phase of the induced phase modulation signal. Frequency translation (via multiplier and or mixing circuit) can be used to mix or move up and or down in frequency the induced phase modulated signal, and is supplied to an input of a (narrow band) filter. The output of the filter is coupled to a frequency translation circuit and or a phase detector (with filtering) to provide a signal that is indicative of the phase modulation from the DUT.

A crash lock or triggered oscillator (which may include a gated input from the modifier's (26) output) may be coupled to the output of the modifying circuit 26 to provide a stable phase signal much like a phase lock loop circuit. The output of the crash lock or trigger oscillator provides a signal to one input of a phase detector, and a second input of the phase detector is coupled to the output of modifier 26. The output of the phase detector (with filtering) then provides a signal indicative of the induced phase modulation from the DUT.

In some cases where the DUT generates distortion from a lower frequency signal into the spectrum of a higher frequency signal. The modifier such as block 26 may (then) include one or more filters, to remove/attenuate signal at or near the frequency around the lower frequency signal and or around the lower frequency signal's distortion product(s) as

to provide a more accurate measurement of phase and or frequency modulation effect on the higher frequency signal. Preferably, the lower frequency signal may be chosen so that its harmonic (or distortion product(s)) does not fall too closely to the sidebands or carrier of the higher frequency signal so that filtering may be done to separate/attenuate adequately one or more distortion products from overlapping into the (phase or frequency modulation) spectrum of the higher frequency signal (e.g., as to improve accuracy of the phase and or frequency modulation measurement of the higher frequency signal). For example, a comb bandpass and or comb notch filter may be used.

Similarly, if a higher frequency signal has distortion product(s) that bleeds or overlaps into the spectrum of a lower frequency signal's spectrum, filtering for modifier (e.g., block 26), as mentioned previously may be used to improve accuracy of the phase and or frequency modulation measurement (e.g., for the lower frequency signal).

It should be noted or reiterated that an embodiment may comprise a subset or portion of FIG. 3, FIG. 10, FIG. 11, FIG. 12, FIG. 13, FIG. 14, FIG. 15, FIG. 16, FIG. 17, FIG. 19, FIG. 20, FIG. 21, FIG. 22, and or FIG. 23. For example, an embodiment of a novel and unique Wow and/or Flutter meter may or may not include a modifier such as exemplified by block(s) 26, 26A, 31, 32, 33, 34, 35, and or 36 (and Wow and Flutter Meter 27), wherein the embodiment measures induced Wow and or Flutter from a device under test (DUT). The (input of the) device or DUT is coupled to a signal source comprising at least two signals; for example, a first signal and a second signal, and or an Nth signal; a first, second, and or Nth signal including a modulated or unmodulated signal; or a signal source comprising at least one modulated signal. A modifier may (substantially) pass a band of frequencies pertaining to the frequency of a first signal or a second signal or an Nth signal. Typically, the frequency of the first signal is not equal to the frequency of the second signal. Or typically, the signal source includes signals of two or more different frequencies, e.g., wherein (typically) the spectrum analysis of the signal source, for example, that is coupled to an input of the DUT, includes two or more different frequencies (e.g., via a first, second, and or Nth signal, or via a modulated signal). Such a novel Wow and/or Flutter meter may include a module/function/generator/signal source to provide at least two signals such as the first, second, or Nth signal (e.g., two or more signals and or a modulated signal that is coupled to a DUT).

Alternatively, a modifier may (substantially) pass a band of frequencies pertaining to one or more distortion products from any combination of the one or more signals coupled to the input of the device (DUT), or a modifier may (substantially) pass a band of frequencies pertaining to any distortion signal from an output of the device. For example, a modifier may pass frequencies around any harmonic distortion product from the output of a device, wherein frequency (and or phase) modulation or deviation or Wow and or Flutter is measured at one or more harmonic distortion product(s) from the DUT. Similarly, a modifier may pass one or more intermodulation distortion product(s) from the DUT for measurement of frequency modulation or deviation or Wow and or Flutter.

An example of two signals may include a first signal of a first frequency and a second signal of a second frequency, wherein the first signal may be unmodulated or modulated, and or the second signal may be unmodulated or modulated. In general, N number of signals coupled to an input of a DUT includes a first signal of a first frequency, and/or a second signal of a second frequency, and/or an Nth signal of an Nth

frequency. A modulated signal may comprise a signal that is modulated (e.g., changed) in amplitude, phase, pulse-width, position, and or frequency.

An embodiment of a novel and unique Wow and or Flutter meter comprises a limiter (circuit, function, or module) for reducing or removing amplitude variations from an output of a DUT which is coupled to an input of the Wow and or Flutter meter, wherein an amplitude modulated signal is coupled to an input of the DUT. The Wow and or Flutter meter (with the limiter circuit/function/module) measures frequency modulation of the carrier of the amplitude modulated signal output from the DUT. The amplitude modulated signal may have a carrier frequency within the audio bandwidth such as any (carrier) frequency in the range of 1 Hz to 20,000 Hz, or a (carrier) frequency greater than or equal to 20,000 Hz. In this example embodiment, a novel and unique Wow and Flutter meter, or frequency modulation measurement system, may include a generator, function, circuit, and or module for providing one or more amplitude modulated signal(s) (e.g., that is typically coupled to an input of a DUT). It should be noted that a standard Wow and Flutter meter is used in a novel way when an amplitude modulated signal (instead of a single unmodulated tone) is utilized to measure Wow and Flutter output from a DUT.

An embodiment may include a new use of a conventional Wow and Flutter meter to measure induced Wow and Flutter from a device's output terminal, wherein an input of the device is coupled to two or more signals or a modulated signal (e.g., two or more signals simultaneously coupled to an input of the DUT, or a modulated signal coupled to an input of the DUT). It is noted that a conventional Wow and Flutter meter couples only one signal, a single tone, to a device for measuring Wow and Flutter.

The term "Wow and/or Flutter meter" may comprise or may equate to a frequency modulation measurement system, a frequency deviation measurement system, or the like. It should be noted that measuring for Wow and or Flutter, or frequency deviation, or frequency modulation may include any combination of a frequency modulation detector (e.g., for a direct measurement), a frequency spectrum analysis such as sideband analysis, and or a phase detector. For example, for an indirect measurement, an output of the phase detector is coupled to an input of a differentiator/derivative function/circuit/module, wherein an output of the differentiator/derivative function/circuit/module provides a measurement for frequency deviation or frequency modulation).

For example, FIG. 20 may include an amplitude modulated signal (via modulator block 131' and summer block 24) that is coupled to an input of the DUT 25, with Signal Gen2 set to zero or near zero. The output of the DUT 25 is coupled to an input of an FM detector, spectrum analysis function, a phase detector, and or a Wow and/or Flutter meter (e.g., block 27' and or block 28') to provide measurement of Wow and/or Flutter, phase modulation, and or frequency modulation in the signal from the DUT. Because Signal Gen2 is set to zero or near zero, which does not provide an "interfering" signal to phase or frequency detectors, modifier 26 may be bypassed in this example, so modifier 26 is optional. Modifier 26 may include a filter to pass a band of frequencies related to the fundamental carrier frequency and or to harmonics of the carrier frequency, so that phase and or frequency modulation effect(s) in a signal from the DUT is measured at the fundamental carrier frequency and or one or more harmonics of the carrier frequency.

For example, a signal with a carrier set at 6 KHz is amplitude modulated (e.g., where modulation frequency includes 150 Hz) and is coupled to an input of a DUT. An output of the

DUT may provide an amplitude modulated signal around 6 KHz and or harmonics of the amplitude modulated signal of the 6 KHz carrier, such as one or more amplitude modulated signal centered around 12 KHz, 18 KHz, and or 24 KHz. A modifier 26 can provide band pass filtering to allow a Wow and/or Flutter meter, phase detector, and or frequency modulation detector (which may include spectrum analysis of sidebands) to measure for the DUT's respective distortions of Wow and/or Flutter, differential phase, and or frequency modulation effect (e.g., frequency shift) at 6 KHz, 12 KHz, 18 KHz, and or 24 KHz. Other carrier, modulation, and or test frequencies may be used for this example.

In another embodiment, Signal Gen2 is enabled and produces a signal that is combined with a modulated signal that is coupled to an input of a DUT. An output of the DUT is coupled to a Wow and/or Flutter meter, phase detector, frequency modulation detector, and or spectrum analysis function, for measurement of differential phase and or frequency modulation from the DUT of one or more signals. The signals may include an intermodulation distortion signal, harmonic distortion signal, and or a fundamental frequency signal of any of the input signals.

As noted previously, an input of a device under test may be coupled to a modulated signal source for measuring one or more phase and or frequency modulation effect from the output of the device under test. For example, a phase or frequency modulated signal, $s(t)$, may include a carrier signal $f(t)$ that is phase or frequency modulated by a signal $mpf(t)$. The phase or frequency modulated signal, $s(t)$, may then be coupled to an input of a DUT, wherein an output of the DUT is coupled (via an optional modifier) to a first input of a phase detector. A second input of a phase detector is coupled to the phase or frequency modulated signal, $s(t)$. An output of the phase detector is coupled to a filter to provide a signal that is indicative of phase modulation from the DUT. It should be noted that if the DUT is bypassed, both inputs of the phase detector receive essentially the same signal from $s(t)$, and even though $s(t)$ includes phase or frequency modulation of its carrier, the resulting differential phase would be cancelled out or close to zero. Therefore, with the DUT between one input of the phase detector and $s(t)$, measurement of differential phase from an output of the DUT is measured, wherein the modulating signal, $mpf(t)$ causes the DUT to exhibit (extra) phase modulation. The output of the phase detector may be coupled to a differentiator circuit or function (e.g., a high pass filter) to provide a signal from an output of the differentiator circuit or function that is indicative of frequency modulation (effect(s)). It should be noted that the phase and or frequency modulated signal $s(t)$ may include amplitude modulation that is amplitude modulated by signal $m2\ am(t)$. The modulating signals $mpf(t)$ and $m2\ am(t)$ may be related in phase and or frequency, or may be (two) independent signals. For example, a phase, frequency, and or amplitude modulated signal, $spfa(t)$, may be used in place of $s(t)$ for testing the DUT (e.g., wherein signal $mpf(t)$ provides phase and or frequency modulation and or signal $m2am(t)$ provides amplitude modulation for signal $spfa(t)$).

In another embodiment, a test signal such as $s(t)$ may include a signal that is amplitude, frequency, and or phase modulated, wherein the test signal is coupled to an input of a DUT, and wherein an output of the DUT is measured for differential phase distortion. For example, an output of the DUT is coupled to a first input of a phase detector, and a second input of the phase detector is coupled to the test signal (e.g., via a limiter circuit or function should the signal $s(t)$ include amplitude modulation). An output of the phase is

filtered to provide a signal indicative of any phase modulation or differential phase distortion from the DUT.

An example of a device under test (DUT) may include any combination of: an amplifier of class A, B, AB, C, D, G, and or H, wherein the amplifier may include a modulated or unmodulated power supply, a system that converts an analog signal to a digital signal, and or a system that converts a digital signal to an analog signal, and or a digital signal processor with data compression (e.g., using Discrete Cosine Transforms, Wavelet Transforms, filter banks, Discrete Fourier Transforms, and or Fourier Transforms).

A device under test (DUT) may include an audio device.

In particular, a class G or class H amplifier includes a modulated power supply that may switch from one voltage or another in a discrete manner, or a modulated power supply that varies or tracks the input signal. In either class G or H amplifiers, the voltage modulation from the power supply may induce a dynamic phase and or frequency effect at an output of the class G or H amplifier. A class D switch amplifier that normally includes a high frequency pulse width modulated waveform to deliver a signal to its output load, may exhibit differential phase or frequency modulation distortion. Class AB, B or C amplifiers include crossover distortion, which can exhibit a phase or frequency modulation distortion greater at a crossover region than elsewhere in the transfer function of the class B or C amplifier. In some class A amplifiers, maximum and minimum gain or output impedance occurs at extremes of the output signal's range (e.g., output voltage or current swing), which leads to phase and or frequency modulation distortion. Thus, an embodiment is to test any class of amplifiers for differential phase and or frequency modulation distortion.

Another embodiment may include frequency and or time scaling (at least a portion) of video signals, such as color bars, a modulated ramp or staircase, a multipulse, multiburst, modulated (sine squared) pulse such as 20 T or 12.5 T, an amplitude modulated signal superimposed on a voltage level, etc., to audio frequencies. For example, a video signal may be scaled (e.g., increased) in time by about 200 times (or in a range of 20 to 2000 times) to provide a test signal to an input of a DUT.

An embodiment may include quadrature phase detectors (e.g., I and Q demodulators) to display or decode a phase modulated signal added to a stepped waveform (of equal or non equal step size) to provide a vectorscope display (e.g., display of a signal in terms of a magnitude and an angle, or display of a signal in polar coordinates). For example, an audio bandwidth color bar signal is coupled to an input of a DUT, wherein an output of the DUT is coupled to a vectorscope to display phase or amplitude shifts from the DUT.

An embodiment may include a test signal, that includes a first signal that is multiplied or amplitude modulated by a second signal, plus a third signal. This test signal for example, is coupled to an input of a DUT, wherein an output of the DUT is coupled to a phase detector, a frequency modulation detector or a spectrum analysis measurement system, to measure phase and or frequency modulation distortion from the DUT. The third signal may be derived from the first and or second signal.

For example, a test signal may have a first signal that includes a sinusoid waveform of a low frequency and second signal that includes a sinusoidal waveform of a high frequency, wherein the third signal (e.g., a sinusoidal waveform or an arbitrary waveform such as any combination of a modulated signal, a continuous wave signal, and or a pulsed signal) is derived from the first signal.

Another example of a test signal comprising three or more signals for measuring differential phase and or frequency modulation distortion.

For example, one test signal includes two high frequency signals, a first high frequency signal of frequency FH1 and a second high frequency signal of frequency FH2 combined with a lower frequency signal of frequency FL1. These three signals are coupled to an input of an audio device and an output of the audio device is coupled to a modifier to remove or attenuate from the output of the audio device, high frequency signals related to frequencies FH1 and or FH2, while passing a signal of (e.g., at least) frequency FL1 to a phase and or frequency detector for measuring differential phase and frequency modulation distortion induced by the first and or second high frequency signal. The phase and or frequency modulation effect from the amplifier may include a frequency related to $|FH1-FH2|$. In one embodiment, the for example, first and second high frequency signals have frequencies above (e.g., about) 3 KHz to (e.g., about) 10 KHz; for another example, the CCIF Twin Tone test signal comprising a 19 KHz (FH1) signal and a 20 KHz (FH2) signal (of course other frequencies for FH1 and FH2 may be used) may be utilized for the first and second high frequency signals. The low frequency signal may include a signal whose frequency is less than the lower of FH1 or FH2. For example, the lower frequency signal has a frequency $FL1 < 19$ KHz. For example only, the lower frequency signal includes a signal whose frequency is ≤ 10 KHz such as 3 KHz to 10 KHz. When the three signals are coupled to an input of an amplifier, the “beating” effect of the two high frequency signals with frequencies FH1 and FH2 will induce phase and or frequency modulation of the signal with frequency FL1 a modulation frequency related to $|FH1-FH2|$, or if $FH1=19$ KHz and $FH2=20$ KHz, then $|FH1-FH2|=1$ KHz—a related modulation frequency onto the signal whose frequency is FL1. Therefore in this example, a CCIF Twin Tone test signal is combined with a lower frequency signal and fed to an audio device to determine or measure the differential phase and or frequency modulation distortion of the lower frequency signal whose frequency is FH1 from an output of the audio device.

Note that a frequency detector may include a Wow and Flutter meter.

An embodiment may include: A system for measuring an induced phase or frequency modulation effect of a device, wherein the device has an input and an output, comprising: a generator for providing a first higher frequency signal, a second higher frequency signal, and a first lower frequency signal for coupling to the input of the device, wherein the output of the device is coupled to an input of a modifier, further comprising the output of the modifier passes signals related to the lower frequency signal while attenuating signals related to the first and or second higher frequency signals to a phase and or frequency detector for measuring differential phase, phase modulation and or frequency modulation related to one or more signals related to the lower frequency signal from the output of the device, and wherein the phase or frequency modulation effect on the lower frequency signal from the output of the device is caused or induced by one or both of the higher frequency signals coupled to the input of the device.

A variation of a test signal for measuring differential phase and or frequency modulation distortion may include two (or more) lower frequency signals with frequencies FL1A and FL1B and a higher frequency signal with frequency FH1A. These three signals are coupled to an input of an amplifier and an output of the amplifier is coupled to modifier to remove or attenuate signals related to FL1A and or FL1B. The output of

the modifier passes a signal related to FH1A to a phase and or frequency detector to determine or measure differential phase and or frequency modulation distortion of a signal related to FH1A from the amplifier’s output induced by any combination of the two lower frequency signals.

Another embodiment includes a test signal for determining differential phase and or frequency modulation distortion includes a first signal combined with a second signal. The first signal (e.g., when decomposed via Fourier or spectral analysis) includes a fundamental frequency signal and at least one harmonic of the first signal. The second signal has a frequency that is higher than the fundamental frequency of the first signal. An audio device (or DUT) is coupled to the first and second signals will then produce differential phase and or frequency modulation induced by the second signal. It was found that phase and frequency modulation effect can be varied by the varying the amplitude of the second signal, and generally, the higher the amplitude of the second signal, the higher the deviation in phase and frequency of signal(s) related to the first signal. Therefore, one other embodiment includes modulation of the second signal by for example amplitude, phase, frequency, and or pulse modulation. To measure differential phase and or frequency modulation of the audio device, an output of the audio device is coupled to an input of a modifier such that an output of the modifier passes a band of frequencies related or near the fundamental frequency and or a harmonic frequency of the first signal. The output of the modifier is then coupled to a phase detector and or frequency modulation detector for measuring differential phase and or frequency modulation at one or more frequencies related to the first signal. The differential phase and or frequency modulation distortion includes distortion induced by the second signal at the input of the audio device and or at the output of the audio device. One or more of the figures and or descriptions (e.g., any combination of FIGS. 3 to 23) involving modifiers, receivers, tuners, filters, frequency translators or mixers, limiters, phase detectors, and or frequency detectors previously mentioned may be utilized for measuring phase or differential phase and or frequency modulation with the test signal including the first signal and the second signal. For example, one or more phase and or frequency detectors may be utilized to provide measurement the phase and frequency modulation effect from an audio device at the fundamental frequency and or one or more harmonics of the first signal, or for measuring differential phase and or frequency modulation distortion related to the second signal. Therefore, an embodiment may include that differential phase and or frequency modulation distortion may be measured for one or more signals related to the (e.g., frequency of) first and or second signal from an output of the audio device. The one or more signals related to the first and or second signal may include one or more distortion product(s) from the first and or second signal (e.g., wherein the audio device provides one or more distortion products at its output).

The first signal that is coupled to the input of the audio device may (or may not) include filtering such as low pass, high pass, band reject, and or band pass to for example shape the frequency response of the first signal. For example, the first signal that is coupled to the audio device may include a low pass filter to attenuate harmonics of the first signal and or a band reject filter to attenuate or remove one or more harmonics from the first signal prior to coupling into the input of the audio device. Any previous, present, and subsequent descriptions of the first signal may (or may) not include filtering as described in this paragraph. It should be noted that any previous, present, and subsequent descriptions of the second signal may (or may not) include an arbitrary wave-

form, a pulsed waveform, and or a modulated waveform, where the modulated waveform may include any combination of phase, frequency, pulse, and or amplitude modulation.

Yet another test signal for determining differential phase and or frequency modulation distortion(s) is to utilize a pulsed waveform and sine wave signal. The sine wave induces differential phase and or frequency modulation distortion onto the pulsed waveform or at a frequency or band around the fundamental frequency of the pulsed waveform, and or a harmonic signal of the pulsed waveform. The pulse waveform and sine wave signal is coupled to an audio device. The output of the audio device is coupled to an input of a modifier (e.g., a modifier may include one or more filters). The modifier's output terminal passes a band of frequencies to a phase detector and or frequency detector for determining differential phase and or frequency modulation distortions from the audio device (e.g. audio amplifier or audio amplifier within a device). The differential phase and or frequency modulation distortion may be measured for signals related to the (e.g., frequency of) first and or second signal from an output of the audio device. Also, note that a phase or frequency detector may include a limiter circuit or limiter function to limit the modified signal from the modifier.

One example of a test signal that comprises of a pulsed signal as a first signal combined with a second signal. A pulsed waveform that may include a squarewave signal (e.g., first signal) combined with a sine wave or arbitrary signal. For example, in the Audio Engineering Society paper, "A Method for Measuring Transient Intermodulation Distortion (TIM)", by Eero Leinonen, Matti Ojala, and John Curl, Journal of the Audio Engineering Society, Oct. 30, 1976, shows a transient intermodulation distortion (TIM) test waveform comprised of a 3.18 KHz squarewave and a 15 KHz sine wave. This TIM test waveform is utilized to measure the amplitudes of intermodulation distortions of an amplifier. However, this Audio Engineering Society (AES) paper from Oct. 30, 1976 does not teach nor mention using this TIM test signal for measuring differential phase and or frequency modulation distortions. New use of this TIM waveform can be utilized for measuring differential phase and or frequency modulation distortion of one or more signals related to a pulsed waveform or a squarewave or the sine wave or arbitrary signal. For example the TIM test signal may or may not include a filtered squarewave that is combined with the second signal. In the AES paper mentioned the squarewave signal is low pass filtered (e.g., low pass filtered at 30 KHz or 100 KHz) and then combined with a 15 KHz sine wave signal to provide the TIM test signal. An embodiment includes a test signal for measuring differential phase and or frequency modulation distortion is comprised of the TIM test signal as described in this paragraph. Another embodiment includes coupling the TIM test signal into an input of an audio device. An output of the audio device outputs a signal including a squarewave or filtered squarewave or a squarewave with modified rise and or fall times, plus a sine wave signal. The output of the audio device is coupled to a modifier to remove or attenuate signals related to the sine wave signal and or to remove or attenuate one or more signals related to the squarewave signal. The output of the modifier is coupled to a phase and or frequency modulation detector to measure differential phase and or frequency modulation of a signal related to the squarewave signal from the output of the audio device.

For example, an embodiment may comprise a 3.18 KHz squarewave signal and a 15 KHz signal (e.g., the squarewave or pulsed signal and or sine wave may be of another frequency) for the TIM test signal to measure differential phase and or frequency modulation distortion at 3.18 KHz, 3×3.18

KHz, 5×3.18 KHz, $N \times 3.18$ KHz and or 15 KHz, where N=an integer (e.g., 1, 2, 3, 4, 5, 6, 7, 8, 9, and or so on). The (e.g., unexpected) phase and modulation frequency for this example is found to be $[5 \times 3.18 \text{ KHz} - 15 \text{ KHz}] = [15.90 \text{ KHz} - 15 \text{ KHz}] = 900 \text{ Hz}$. Other frequencies may be utilized. For example the pulsed waveform frequency set at 3 KHz, and the sine wave frequency set at 14.15 KHz, which yields a (e.g., unexpected) phase and frequency modulating frequency of $[5 \times 15 \text{ KHz} - 14.15 \text{ KHz}] = 850 \text{ Hz}$. An apparatus or method to measure the differential phase and or frequency modulation of an audio device comprises of coupling the TIM test signal to an input the audio device, coupling an output of the audio device to a modifier to remove or attenuate one or more signals or to a modifier to pass one or more bands of frequencies related to the pulse waveform frequency (e.g., 3.18 KHz or $N \times 3.18$ KHz or 3 KHz or $N \times 3$ KHz) to one or more phase detectors and or to one or more frequency detectors that convert(s) the differential phase and or frequency deviation into a current or voltage signal. For example, a filter or nulling or cancellation circuit may be used to remove sine wave signal (e.g., at 15 KHz or 14.15 KHz) from the output of the amplifier prior to coupling to a phase and or frequency detector to measure the differential phase at $N \times 3.18$ KHz or $N \times 3$ KHz, where N=an integer. The filter may include any combination of low pass, high pass, band pass, and or band reject filter. For example, a low pass filter may be coupled to the output of the amplifier to attenuate signals above the fundamental frequency of the squarewave while still pass at least one sideband above the squarewave's fundamental frequency. The sideband(s) around the fundamental frequency and or harmonics of the first signal will be typically distanced or away from the fundamental frequency or harmonics of the first signal by $M \times [\text{modulating frequency}]$, where M=integer, or a multiple (e.g., 1, 2, 3, . . . etc.) of the phase and or frequency modulation frequency such as $[5 \times 3.18 \text{ KHz} - 15 \text{ KHz}] = [15.90 \text{ KHz} - 15 \text{ KHz}] = 900 \text{ Hz}$ or $[5 \times 15 \text{ KHz} - 14.15 \text{ KHz}] = 850 \text{ Hz}$ from either side (e.g., upper or lower sideband) of the fundamental frequency or harmonics of the first signal. The modulating frequency in general is $|N \times f_1 - f_2| < f_3$, where N is an integer, f_1 is the frequency of the first signal or pulsed waveform (e.g., squarewave), f_2 is the frequency of the second signal or sine wave signal, and f_3 is an upper frequency limit and for example, f_3 is generally less than 2 KHz. A 4 KHz to 6 KHz low pass filter may be utilized as a filter to pass a band of frequencies to measure phase and frequency modulation distortion at the pulsed waveform or squarewave frequency of 3.18 KHz or 3 KHz. Alternatively, a band pass filter may be used at 3.18 KHz or 3 KHz, 9.54 KHz or 9 KHz to measure differential phase and or frequency modulation of an amplifier at any of these frequencies (e.g., wherein the differential phase and frequency modulation is induced by the 15 KHz or 14.15 KHz sine wave signal).

Alternatively, a low pass filter in the range of 10 KHz or higher (e.g., 11 KHz to 13 KHz) may be utilized to remove the sine wave signal of 15 KHz or 14.15 KHz to determine or measure the differential phase and or frequency modulation of a pulsed waveform comprising the fundamental frequency and at least one of its harmonics. For example, an 11 KHz to 13 KHz low pass filter will pass the fundamental frequency and up to the 3rd harmonic of the pulsed waveform or squarewave signal to provide measuring differential phase and or frequency modulation of a "filtered" pulse waveform or filtered squarewave wherein the differential phase and or frequency modulation is induced by the sine wave signal (e.g., 15 KHz or 14.15 KHz signal).

An embodiment may include coupling the TIM test signal that includes a first signal and second signal to an input of an

audio device, wherein the first signal comprises a pulsed waveform, further coupling an output of the audio device to an input of a filter or a cancellation circuit that attenuates or removes a signal at the output of the audio device related to the second signal, further coupling an output of the filter or cancellation circuit to a phase and or frequency detector to measure differential phase and or frequency modulation distortion from the audio device that is induced by the second signal. For example, the TIM test signal comprising a 3.18 KHz or 3 KHz square wave signal combined with a 15 KHz or 14.15 KHz sine wave signal (e.g., respectively) is coupled to an input of an audio device (e.g., amplifier), an output of the audio device is coupled to an input of a modifier such that at an output of the modifier, the 15 KHz or 14.15 KHz signal is attenuated while passing the 3.18 KHz or 3 KHz squarewave from the output of the audio device to a phase and or frequency detector for measuring differential phase and or frequency modulation distortion that is induced by the second signal. Therefore, the differential phase and or frequency modulation distortion of the pulsed waveform or squarewave from the output of the audio device or amplifier is measured. A cancellation circuit may include adding an out of phase portion of the second signal derived from a generator that provides the second signal to the input of the amplifier to combine with the output signal of the audio device such that the second signal at the output of the audio device is nulled or attenuated.

Another embodiment may include a modified TIM test signal. An example of a modified TIM test signal comprises a first signal such as a (e.g., 3 KHz) pulsed waveform (e.g., a waveform of duty cycle between 0% and 100%, or a square-wave, or a waveform of wherein $1/[\text{duty cycle}]$ or the reciprocal of the duty cycle is a whole number or integer) that is combined with a second signal whose frequency is higher than the 5^{th} or Nth harmonic, where $N=\text{integer}$. For example, a 3 KHz signal such as a squarewave (or pulsed waveform) is utilized for the first signal and a 20 KHz signal (e.g., sine wave or arbitrary waveform) is utilized for the second waveform. The 3 KHz signal may or may not include filtering when combined with the 20 KHz signal to form or provide a modified TIM test signal. The modified TIM test signal is coupled to an input of an audio device. An output of the audio device is coupled to an input of a modifier and an output of the modifier provides removal or attenuation of the 20 KHz signal from the output of the audio device. Also the output of the modifier provides signals related to the first signal for measuring differential phase and frequency modulation distortions at 3 KHz, and $N \times 3$ KHz, where $N=\text{integer}$. For example, the modifier then passes signals related to the pulsed waveform at 3 KHz, 9 KHz, and or 15 KHz to allow measuring differential phase and or frequency modulation at 3 KHz, 9 KHz, and or 15 KHz. The modifier may include one or more band pass filters to provide one or more outputs to pass separately signals centered around 3 KHz, 9 KHz, and or 15 KHz. Each or at least one band pass filter output may be coupled to phase and or frequency detectors to measure the differential phase and or frequency modulation distortion at one or more frequencies (e.g., 3 KHz, 9 KHz, and or 15 KHz), wherein the phase and frequency modulation frequency is $|N \times f_1 - f_2| < f_3$, where N is an integer, f_1 is the frequency of the first signal or pulsed waveform (e.g., squarewave), f_2 is the frequency of the second signal or sine wave signal, and f_3 is an upper frequency limit and for example, f_3 is generally less than 2 KHz. In this example, $f_1=3$ KHz, $N=7$, $f_2=20$ KHz, which results in 7×3 KHz $- 20$ KHz $= 1$ KHz $=$ modulation fre-

quency. Of course the modified (e.g., TIM) test signal may include frequencies other than 3 KHz for f_1 and or frequencies other than 15 KHz for f_2 .

An embodiment may include second modified TIM signal that includes a first signal comprising a filtered pulsed waveform or a non symmetrical pulse in terms of duration and a second signal. The first signal comprises signals of the fundamental frequency and harmonics with at least one harmonic (e.g., Nth harmonic) attenuated by filtering or attenuated by the non symmetrical duration (e.g., if the reciprocal of the duty cycle is a whole number, P , then the pulse will provide a signal of the fundamental frequency and its harmonics except signals related to the Pth harmonic and except signals whose frequency is every harmonic that is a multiple of P) and the frequency of the second signal may include a frequency in the range between the $(N-1)$ or $(P-1)$ harmonic and the $(N+1)$ or $(P+1)$ harmonic. This second modified TIM signal is then coupled to an input of an audio device and an output of the audio device is coupled to a modifier to remove one or more signals related to the first and or second signals. The modifier also passes signals related to the first signal from the audio device that is coupled to a phase and or frequency detector to measure differential phase and or frequency modulation (e.g., effects) of one or more signals related to the first signal from the output of the audio device.

And embodiment may include: An embodiment may include: A system for measuring an induced phase or frequency modulation effect of, an audio device, wherein the audio device has an input and an output, comprising: a first generator for providing first signal comprising a pulsed waveform and a second generator for providing a second signal whose frequency is higher than the frequency of the first signal to an input of the audio device; wherein the output of the audio device is coupled to a Wow and Flutter meter, a phase detector, and or a frequency modulation detector, measuring via the phase detector and or the frequency modulation detector the induced phase or frequency modulation effect of one or more signals related to the pulsed waveform at the output of the audio device; and wherein the phase or frequency modulation effect on one of the input signals is caused or induced by the second signal coupled to the input of the audio device.

FIG. 24 shows a low frequency generator, 241, that is combined or summed via 244 with one or more higher frequency generator(s), 242 and or 243. Generator 243 represents an Nth higher frequency generator. A lower frequency generator (e.g., generator 241) may include an arbitrary waveform, a sinusoidal waveform, a pulsed waveform, a stairstep or staircase waveform, bipolar waveform, and or (e.g. low pass) filter. The output of the summer 244 is then connected or coupled to the DUT (device under test). An output of the DUT, 245 is then coupled to one or more bandpass filters 246, 247, and or 248. Note: the higher frequency test tones or test signals may include frequency or frequencies of F_i and or F_j . The bandpass filters are tuned or provide(s) a bandpass to frequency or frequencies of the harmonic (e.g., frequency or frequencies of $n \times F_i$) or intermodulation (e.g., frequency or frequencies of $m \times F_i + / - p \times F_j$) distortion signals. For example, if one of the higher frequency tones is 1 kHz, the filters may be tuned or allow to pass signals at 2 kHz, 3 kHz, and or $n \times 1$ kHz, etc. where $n \geq 2$ for example. The bandwidth of the filters in the filter bank (e.g., 246, 247, and or 248) may be sufficiently wide to avoid ringing. That is if the bandpass filters are narrow in bandwidth, erroneous readings may occur because of ringing effects from the low frequency signal (e.g., where a low frequency signal includes a stairstep signal or 2 or more levels). One example of bandwidth is in

55

the order or 20% or more of the bandpass frequency. Of course other bandwidth numbers may be used for minimizing ringing while providing an accurate real time analysis of the distortion.

For example with a 6 kHz test tone and a stairstep signal (e.g., 20 ms period or 5 steps), the bandpass filter at 12 kHz (e.g., second harmonic of 6 kHz) has a 4 kHz or more bandwidth. Note: An FFT analysis that places the harmonic or intermodulation distortion in a bin typically will have narrow band characteristics that may cause an inaccuracy in the measurement of time varying harmonic and or intermodulation distortion.

FIG. 25 shows that phase and or frequency modulation effects from one or more of the distortion signal from one or more of bandpass filters. Phase modulation and or frequency modulation detectors or demodulators shown in 251, 252, and or 253 allow(s) measurement of dynamic phase shift and or frequency shift from the harmonic and or intermodulation distortion from the DUT. For example, the dynamic phase shift or frequency shift is provided via the lower frequency signal inducing time varying offset levels, which then causes some devices to produce varying amounts of harmonic and or intermodulation distortion as a function of the offset voltage, which then can provide time varying phase and frequency shifts in the harmonic and or intermodulation distortion signal(s). Phase or frequency demodulator 252 or 253 may be optional. Phase or frequency demodulator 251 may be coupled to the output of any one of the bandpass filters or any portion of the filter bank. One or more bandpass filters may form or provide a filter bank. In terms of bandwidth of the bandpass filters that comprise a filter bank, sufficient bandwidth is required to allow passage of sufficient sidebands around the frequency of the distortion product as to allow proper or accurate phase and or frequency demodulation. For example, too narrow a bandwidth will produce erroneously low readings on the phase and or frequency modulation effect from the DUT.

FFT may also be used to measure time varying harmonic and or intermodulation distortion.

Also note that the filter banks may be implemented in any combination of analog circuits, digital circuits, software, digital signal processing, and or computational apparatus.

Alternatively, an FFT (Fast Fourier Transform) or DFT (Discrete Fourier Transform) may be taken at any portion or interval of the lower frequency signal (e.g., block 241 in FIG. 24) at the output of the DUT to measure for harmonic and or intermodulation distortion. For example, if a stepped signal is used, filter banks as previously described may be used to measure time varying harmonic and or intermodulation distortion. Alternatively, an FFT can be applied during a portion of one or more of the steps of the stepped signals to provide a measurement of harmonic and or intermodulation distortion.

FIG. 26 shows an example measurement from a device under test (e.g., an op amp such as a TL082 op amp). The top trace shows harmonic distortion for a 5 step signal example. The bottom trace shows the test signal waveform, a 5 step staircase low frequency signal combined with a higher frequency signals (e.g., a sinewave whose frequency is within an audio bandwidth of 22 kHz). The distortion displayed from the output shows more distortion on the third step where the offset or stairstep voltage is zero than at other steps where there is a transient DC offset voltage on the first or second or fourth step. Note the fifth step which represents measuring harmonic distortion where the output signal is near the negative rail or power supply, the harmonic distortion is largest in this example. The harmonic distortion displayed in FIG. 26 may be the nth harmonic where $n \geq 2$.

56

FIG. 27 shows a different example of a low frequency signal. A low frequency sine wave replaces the stairstep waveform and two or more test signals of higher frequencies are combined or added to the low frequency sine wave signal to provide a test signal for evaluating time varying intermodulation distortion of the nth order where $n \geq 2$. For example, the lower frequency signal may have a frequency < 1 kHz, and the two or more test signals added to the lower frequency signal may be > 10 kHz. Of course other frequencies may be used.

FIG. 28 shows an example of time varying intermodulation distortion from an amplifier or audio device (e.g., an LM1458 op amp). The top trace shows the low frequency sine wave signal and the bottom trace shows intermodulation distortion (e.g., 2nd order intermodulation distortion or nth order intermodulation distortion) that is time varying. At near the zero crossing of the lower frequency signal on the top trace, the intermodulation distortion is at a minimum, and the bottom trace also shows that during the positive cycle of the lower frequency signal, the intermodulation distortion is lower than during the negative cycle. Also note that the time varying intermodulation distortion in this example resembles a “dumb-bell” pattern during the negative cycle of the lower frequency signal (e.g., sinewave on top trace).

In general, the pattern of the time varying harmonic and or intermodulation distortion is hard to predict and direct measurement is used to determine the “pattern” or distribution of the time varying or dynamic harmonic and or intermodulation. For example, there are some amplifiers that will show harmonic distortion in one or two of the five steps of a five step staircase or stairstep signal. But other amplifiers will show a different distribution of distortion over the different steps or different offset voltages. Likewise in some amplifiers, there will be little or close to zero intermodulation distortion during one cycle of the lower frequency signal, and quite measureable intermodulation distortion in the other cycle of the lower frequency signal.

Any signal, or signals, that is, or are, utilized for testing (or for measuring differential gain, differential phase, and or frequency modulation distortion) may include synthesizing a signal or waveform via a series of discrete time values such as generated from a computational circuit, module, and or program, and or wherein the values are read from a memory device. In general, any signal or signals for testing may be provided via in an analog domain, digital domain, and or software domain.

This disclosure is illustrative and not limiting; further modifications will be apparent to one skilled in the art and are intended to fall within the scope of the appended claims and or of the embodiments described.

The invention claimed is:

1. Method for measuring in a time domain, time varying harmonic distortion from an audio device, wherein the audio device has an input and an output, comprising:

providing a first signal comprising a pulsed, sinusoidal, stairstep, staircase, bipolar, and or arbitrary waveform and a second signal whose frequency is higher than the frequency of the first signal, to an input of the audio device;

coupling the output of the audio device to an input of a filter bank, and wherein the filter bank includes, at least one output terminal;

measuring the time varying harmonic distortion via measuring or displaying the amplitude level from one of the output terminals of the filter bank to provide the time varying harmonic distortion measurement of the audio device,

57

wherein the time varying harmonic distortion includes a harmonic distortion signal of the second signal, and wherein the harmonic distortion signal of the second signal is varied or induced by the first signal.

2. The method of claim 1 wherein the filter bank includes at least one filter circuit.

3. The method of claim 1 wherein at the filter bank includes at least one bandpass filter.

4. The method of claim 1 wherein the measurement of time varying harmonic distortion includes measuring time varying harmonic distortion at one or more frequencies.

5. The method of claim 4 wherein the measuring of time varying harmonic distortion at one or more frequencies includes measuring, the time varying harmonic distortion simultaneously.

6. The method of claim 1 further comprising coupling one of the output terminals of the filter bank to a phase and or frequency modulation demodulator to measure phase and or frequency modulation from one or more time varying harmonic distortion signals.

7. The method of claim 1 further comprising measuring from time varying amplitude, differential gain, and or differential phase of one or more time varying harmonic distortion signals.

8. The method of claim 1 wherein the second signal comprises two or more signals.

9. The method of claim 8 further comprising measuring from at least one output of the filter bank phase and or frequency modulation from at least one harmonic distortion signal, and or measuring time varying amplitude, differential gain or differential phase from at least one time varying harmonic distortion signal.

10. An apparatus for measuring in a time domain time varying or dynamic harmonic distortion from an audio device, wherein the audio device has an input and an output, comprising;

providing a first signal comprising a pulsed sinusoidal, stairstep, staircase, bipolar, and or arbitrary waveform and a second signal whose frequency is higher than the frequency of the first signal, to an input of the audio device;

coupling the output of the audio device to an input of a filter bank, and wherein the filter bank includes at least one output terminal;

measuring the time varying harmonic distortion via measuring or displaying the amplitude level from the output terminal of the filter bank to provide the time varying harmonic distortion measurement of the audio device, wherein the time varying harmonic distortion includes a harmonic distortion signal of the second signal, and wherein the harmonic distortion signal of the second signal is varied or induced by the first signal.

11. The apparatus of claim 10 wherein the filter bank includes at least one filter circuit.

12. The apparatus of claim 10 wherein at the filter bank includes at least one bandpass filter.

58

13. The apparatus of claim 10 wherein the measurement of time varying harmonic distortion includes measuring time varying harmonic distortion at one or more frequencies.

14. The apparatus of claim 13 wherein the measuring of time varying harmonic distortion at one or more frequencies includes measuring the time varying harmonic distortion simultaneously.

15. The apparatus of claim 10 further comprising coupling one of the output terminals of the filter bank to a phase and or frequency modulation demodulator to measure phase and frequency modulation from one or more time varying harmonic distortion signals.

16. The apparatus of claim 10 further comprising measuring from time varying amplitude, differential gain, and or differential phase of one or more time varying harmonic distortion signals.

17. The apparatus of claim 10 wherein the second signal comprises two or more signals.

18. The apparatus of claim 17 further comprising measuring from at least one output of the filter bank phase and or frequency modulation from at least one time varying harmonic distortion signal, and or measuring time varying amplitude, differential gain or differential phase from at least one time varying harmonic distortion signal.

19. An apparatus for measuring in a time domain time varying intermodulation distortion from an audio device, wherein the audio device has an input and an output, comprising;

providing the first signal and the second signal and including a third signal whose frequency is different from the frequency of the second signal, wherein the second, and third signals are higher in frequency than the frequency of the first signal,

coupling the first, second, and third signals to an input of the audio device;

coupling the output of the audio device to an input of a filter bank, and wherein the filter bank includes at least one filter and at least one output terminal;

measuring the time varying intermodulation distortion via measuring or displaying the amplitude level from the output terminal of the filter bank to provide the time varying intermodulation distortion measurement of the audio device,

wherein the time varying intermodulation distortion measurement includes measuring an intermodulation distortion signal of the second and the third signals, and wherein the time varying intermodulation distortion signal is varied or induced in time by the first signal.

20. The apparatus of claim 19 further comprising coupling one of the output terminals of the filter bank to a phase and or frequency modulation demodulator to measure phase and frequency modulation from one or more time varying intermodulation distortion signals.

* * * * *