



(11) **EP 1 547 730 B1**

(12) **EUROPEAN PATENT SPECIFICATION**

(45) Date of publication and mention of the grant of the patent:
03.10.2007 Bulletin 2007/40

(51) Int Cl.:
B25H 3/02 (2006.01) A47B 49/00 (2006.01)

(21) Application number: **03029819.4**

(22) Date of filing: **23.12.2003**

(54) **Storage rack**

Lagergestell

Casier de stockage

(84) Designated Contracting States:
AT BE BG CH CY CZ DE DK EE ES FI FR GB GR HU IE IT LI LU MC NL PT RO SE SI SK TR

(43) Date of publication of application:
29.06.2005 Bulletin 2005/26

(73) Proprietor: **Global Industries Holdings Ltd.**
Nassau,
New Providence (BS)

(72) Inventor: **Yang, Qinghao**
Pu Dong
Shanghai 200122 (CN)

(74) Representative: **Hackett, Sean James et al**
Marks & Clerk
Alpha Tower
Suffolk Street Queensway
Birmingham B1 1TT (GB)

(56) References cited:
EP-A- 1 364 753 CH-A- 662 487
DE-U- 9 205 444 DE-U- 29 517 259
US-A- 4 895 256 US-A- 6 105 767

EP 1 547 730 B1

Note: Within nine months from the publication of the mention of the grant of the European patent, any person may give notice to the European Patent Office of opposition to the European patent granted. Notice of opposition shall be filed in a written reasoned statement. It shall not be deemed to have been filed until the opposition fee has been paid. (Art. 99(1) European Patent Convention).

Description**BACKGROUND OF THE INVENTION****1. Field of the Invention:**

[0001] The present invention relates to storage racks according to the preamble of claims 1 and 5;

2. Description of the Related Art:

[0002] Such a storage rack is known from EP 1364753A1

[0003] Various storage boxes are known for keeping accessories and small items. These storage boxes commonly comprise a box body defining a plurality of compartments for keeping different accessories, and a cover hinged to the box body. Several storage boxes may be joined, forming a storage rack.

[0004] There is known a loose-leaf type storage rack, which comprises a pivot shaft, a plurality of trays, and a plurality of flat accessories boxes mounted in the trays. The trays each have a plurality of knuckles respectively pivotally coupled to the pivot shaft such that the trays are arranged in a stack and can be turned about the pivot shaft together or respectively relative to one another. Positioning structure (not shown) is provided between the pivot shaft and the knuckles such that the trays can be respectively positioned in the desired angular position after having been turned about the pivot shaft. This design of loose-leaf type storage rack is functional. However, because the flat accessories boxes are available in only one single size, the user cannot arrange different sizes of flat accessories boxes in the trays to provide different combinations.

[0005] Moreover with this type of storage rack, shown in EP-A-1364753, there is little press-fit or other positive engagement between said trays, constituting carrier frames, and said flat accessories boxes, constituting box bodies, which box bodies are thus easily detachable from the carrier frames.

SUMMARY OF THE INVENTION

[0006] The above-mentioned problem is solved by a storage rack according to Claim 1 and also by a storage rack according to Claim 5. Further advantages of the invention are disclosed by the dependent Claims 2 to 4 and 6 to 8.

BRIEF DESCRIPTION OF THE DRAWINGS**[0007]**

FIG. 1 is an elevational view of a storage rack according to the present invention.

FIG. 2 is an exploded view of the storage rack according to the present invention.

FIG. 3 is an exploded view in an enlarged scale of a part of the present invention.

FIG. 4 is an assembly view of FIG. 3.

FIG. 5 is a sectional view taken along line 5-5 of FIG. 4.

FIG. 6 is a sectional view taken along line 6-6 of FIG. 4.

FIG. 7 is another exploded view of the storage rack according to the present invention.

FIG. 8 is still another exploded view of the storage rack according to the present invention.

FIG. 9 is still another exploded view of the storage rack according to the present invention.

15 DETAILED DESCRIPTION OF THE PREFERRED EMBODIMENT

[0008] Referring to FIG. 1, a storage rack is shown comprising a pivot shaft **40**, a plurality of trays **10;20;30**, and a plurality of flat accessories boxes **12;22;32** mounted in the trays **10;20;30**. The trays **10;20;30** each have a plurality of knuckles **11;21;31** respectively pivotally coupled to the pivot shaft **40** such that the trays **10;20;30** are arranged in a stack and can be turned about the pivot shaft **40** together or respectively relative to one another. Positioning structure (not shown) is provided between the pivot shaft **40** and the knuckles **11;21;31** such that the trays **10;20;30** can be respectively positioned in the desired angular position after having been turned about the pivot shaft **40**. The flat accessories boxes **12;22;32** have different sizes, i.e., a tray **10;20;30** can carry one big-size flat accessories box **12** (see FIG. 2), two medium-size flat accessories boxes **22** (see FIG. 7), or four small-size flat accessories boxes **32** (see FIG. 8).

[0009] Referring to FIGS. 2-6, each tray **10;20;30** has at least two locating blocks **50** upwardly disposed at the top and arranged at right angles; each flat accessories box **12;22;32** has a plurality of recessed bottom locating holes **51** corresponding to the locating blocks **50** at the tray **10;20;30**. Because the trays **10;20;30** and the flat accessories boxes **12;22;32** are molded from plastics, the locating blocks **50** are springy, and the recessed bottom locating holes **51** are slightly expansible. When put the flat accessories boxes **12;22;32** in the trays **10;20;30**, the respective locating blocks **50** are respectively press-fitted into the respective recessed bottom locating holes **51**, thereby causing the flat accessories boxes **12;22;32** to be respectively firmly secured to the trays **10;20;30**. The friction force between the respective flat accessories boxes **12;22;32** and the respective trays **10;20;30** is sufficient to firmly secure the into the respective recessed bottom locating holes **51**, thereby causing the flat accessories boxes **12;22;32** to the trays **10;20;30**, and the flat accessories boxes **12;22;32** do not fall from the trays **10;20;30** when turning the trays **10;20;30** about the pivot shaft **40**.

[0010] Referring to FIGS. 2, 7, and 8, each tray **10;20;30** has two oval through holes **13;23;33** symmetrically

disposed near two opposite lateral sides. The user can insert a finger through the oval through holes **13;23;33** to push the flat accessories boxes **12;22;32** upwardly away from the trays **10;20;30** in direction reversed to the bonding direction between the locating blocks **50** and the recessed bottom locating holes **51**. Therefore, the recessed bottom locating holes **51** can be smoothly disengaged from the locating blocks **50** without damaging the locating blocks **50**.

[0011] Referring to FIG. 7, the tray **20** carrying two medium-size flat accessories boxes **22** is seen after opening of the tray **10** carrying one big-size flat accessories box **12** from the other trays. The medium-size flat accessories boxes **22** are about one half of the size of one big-size flat accessories box **12**. Every medium-size flat accessories box **22** has a plurality of bottom locating holes **51** disposed adjacent to three of the four sides thereof and connected to corresponding locating blocks **50** at the tray **20**.

[0012] Referring to FIG. 8, the tray **30** carrying four small-size flat accessories boxes **32** is seen after opening of the tray **10** carrying one big-size flat accessories box **12** with the tray **20** carrying two medium-size flat accessories boxes **22**. The small-size flat accessories boxes **32** are about one half of the size of one medium-size flat accessories box **22**. Every small-size flat accessories box **32** has a plurality of recessed bottom locating holes **51** disposed adjacent to two of the four sides thereof and connected to corresponding locating blocks **50** at the tray **30**.

[0013] Referring to FIG. 9, one medium-size flat accessories box **22** and two small-size flat accessories boxes **32** can be carried in one tray **20**. By means of the recessed bottom locating holes **51** at the flat accessories boxes **12;22; 32** and the locating blocks **50** at the trays **10;20;30**, the flat accessories boxes **12;22;32** can detachably and selectively set in the trays **10;20;30**.

[0014] A prototype of storage rack has been constructed with the features of the annexed drawings of FIGS. 1-9. The storage rack functions smoothly to provide all of the features discussed earlier.

Claims

1. A storage rack comprising a pivot shaft (40), a plurality of trays (10; 20; 30) molded from plastics and respectively pivoted to said pivot shaft (40), a plurality of flat accessories boxes (12; 22; 32) molded from plastics and respectively detachably carried in said trays (10; 20; 30); a positioning structure adapted to secure said flat accessories boxes (12; 22; 32) to said trays (10; 20; 30), **characterised by** said positioning structure comprising a plurality of recessed locating holes (51) disposed at a bottom side of each of said flat accessories boxes (12; 22; 32), and a plurality of locating blocks (50) provided at a top side of each of said trays (10; 20; 30) and adapted to

engage said recessed locating holes (51), and by said trays (10; 20; 30) each having a plurality of through holes (13; 23; 33) symmetrically disposed near two opposite lateral sides thereof for the insertion of the user's finger to push said flat accessories boxes (12; 22; 32) away from said trays.

2. A storage rack as claimed in Claim 1 wherein the number of recessed locating holes (51) at each said flat accessories box (12; 22; 32) is equal to the number of the locating blocks (50) at each said tray (10; 20; 30).

3. A storage rack as claimed in Claim 1 or Claim 2, wherein said recessed locating holes (51) are respectively arranged along three of four sides of each said flat accessories box (12; 22; 32) and coupled to corresponding locating blocks (50) at said trays (10; 20; 30).

4. A storage rack as claimed in Claim 1 or Claim 2, wherein said recessed locating holes (51) are respectively arranged along two adjacent sides of each said flat accessories box (12; 22; 32) and coupled to corresponding locating blocks (50) at said trays (10;20; 30).

5. A storage rack comprising a pivot shaft (40), a plurality of trays (10; 20; 30) molded from plastics and respectively pivoted to said pivot shaft (40), a plurality of flat accessories boxes (12; 22; 32) moulded from plastics and respectively detachably carried in said trays (10; 20; 30); a positioning structure adapted to secure said flat accessories boxes (12; 22; 32) to said trays (10; 20; 30), **characterised by** said positioning structure comprising a plurality of recessed locating holes(51) formed in a bottom side of each said flat accessories box (12; 22; 32), and a plurality of locating blocks (50) respectively formed integral with said trays (10; 20; 30) along each of four peripheral sides of each tray (10; 20; 30) and adapted to engage said recessed locating holes (51), and by said trays (10; 20; 30) each having a plurality of through holes (13; 23; 33) symmetrically disposed near two opposite lateral sides thereof for the insertion of the user's finger to push said flat accessories boxes (12; 22; 32) away from said trays.

6. A storage rack as claimed in Claim 5, wherein the number of the recessed locating holes (51) at each said flat accessories box (12; 22; 32) is equal to the number of the locating blocks (50) at each said tray (10; 20; 30).

7. A storage rack as claimed in Claim 5 or Claim 6, wherein said recessed locating holes (51) are respectively arranged along three or four sides of each said flat accessories box (12; 22; 32) and coupled

to corresponding locating blocks (50) at said trays (10; 20; 30).

8. A storage rack as claimed in Claim 5 or Claim 6, wherein recessed locating holes (51) are respectively arranged along two adjacent sides of each said flat accessories box (12; 22; 32) and coupled to corresponding locating blocks (50) at said trays (10; 20; 30).

Patentansprüche

1. Lagergestell, umfassend eine Gelenkwelle (40), eine Mehrzahl von aus Kunststoff geformten und jeweils an der Gelenkwelle (40) drehbar gelagerten Ablagen (10; 20; 30), eine Mehrzahl von aus Kunststoff geformten und von den Ablagen (10; 20; 30) abnehmbar getragenen flachen Zubehörkästen (12; 22; 32); eine Positionierstruktur, die darauf eingerichtet ist, die flachen Zubehörkästen (12; 22; 32) sicher an den Ablagen (10; 20; 30) zu befestigen, **dadurch gekennzeichnet, dass** die Positionierstruktur eine Mehrzahl von ausgesparten Fixierlöchern (51), die an einer Unterseite jedes der flachen Zubehörkästen (12; 22; 32) angeordnet sind, und eine Mehrzahl von Fixierblöcken (50) umfasst, die in der Oberseite jeder der Ablagen (10; 20; 30) vorgesehen und darauf eingerichtet sind, in die ausgesparten Fixierlöcher (51) einzugreifen, und dass die Ablagen (10; 20; 30) jeweils eine Mehrzahl von Durchgangslöchern (13; 23; 33) aufweisen, die symmetrisch in der Nähe der beiden gegenüberliegenden lateralen Seiten der Ablagen zum Einführen des Fingers des Benutzers angeordnet sind, um die flachen Zubehörkästen (12; 22; 32) von den Ablagen wegzudrücken.
2. Lagergestell nach Anspruch 1, wobei die Anzahl der ausgesparten Fixierlöcher (51) in jedem der flachen Zubehörkästen (12; 22; 32) gleich der Anzahl der Fixierblöcke (50) in jeder der Ablagen (10; 20; 30) ist.
3. Lagergestell nach Anspruch 1 oder 2, wobei die ausgesparten Fixierlöcher (51) jeweils entlang drei von vier Seiten jedes flachen Zubehörkastens (12; 22; 32) angeordnet und an die entsprechenden Fixierblöcke (50) an den Ablagen (10; 20; 30) gekoppelt sind.
4. Lagergestell nach Anspruch 1 oder 2, wobei die ausgesparten Fixierlöcher (51) jeweils entlang zweier benachbarter Seiten jedes flachen Zubehörkastens (12; 22; 32) angeordnet und an die entsprechenden Fixierblöcke (50) an den Ablagen (10; 20; 30) gekoppelt sind.
5. Lagergestell, umfassend eine Gelenkwelle (40), ei-

ne Mehrzahl von aus Kunststoff geformten und jeweils an der Gelenkwelle (40) drehbar gelagerten Ablagen (10; 20; 30), eine Mehrzahl von aus Kunststoff geformten und von den Ablagen (10; 20; 30) abnehmbar getragenen flachen Zubehörkästen (12; 22; 32); eine Positionierstruktur, die darauf eingerichtet ist, die flachen Zubehörkästen (12; 22; 32) sicher an den Ablagen (10; 20; 30) zu befestigen, **dadurch gekennzeichnet, dass** die Positionierstruktur eine Mehrzahl von ausgesparten Fixierlöchern (51), die in einer Unterseite jedes der flachen Zubehörkästen (12; 22; 32) ausgebildet sind, und eine Mehrzahl von Fixierblöcken (50) umfasst, die jeweils integral mit den Ablagen (10; 20; 30) entlang jeder der vier peripheren Seiten jeder Ablage (10; 20; 30) geformt und darauf eingerichtet sind, in die ausgesparten Fixierlöcher (51) einzugreifen, und dass die Ablagen (10; 20; 30) jeweils eine Mehrzahl von Durchgangslöchern (13; 23; 33) aufweisen, die symmetrisch in der Nähe der beiden gegenüberliegenden lateralen Seiten der Ablagen zum Einführen des Fingers des Benutzers angeordnet sind, um die flachen Zubehörkästen (12; 22; 32) von den Ablagen wegzudrücken.

6. Lagergestell nach Anspruch 5, wobei die Anzahl der ausgesparten Fixierlöcher (51) an jedem flachen Zubehörkasten (12; 22; 32) gleich der Anzahl der Fixierblöcke (50) an jeder Ablage (10; 20; 30) ist.
7. Lagergestell nach Anspruch 5 oder 6, wobei die ausgesparten Fixierlöcher (51) jeweils entlang drei von vier Seiten jedes flachen Zubehörkastens (12; 22; 32) angeordnet und an die entsprechenden Fixierblöcke (50) an den Ablagen (10; 20; 30) gekoppelt sind.
8. Lagergestell nach Anspruch 5 oder 6, wobei die ausgesparten Fixierlöcher (51) jeweils entlang zweier benachbarter Seiten jedes flachen Zubehörkastens (12; 22; 32) angeordnet und an die entsprechenden Fixierblöcke (50) an den Ablagen (10; 20; 30) gekoppelt sind.

Revendications

1. Casier de stockage comprenant un axe de pivot (40), plusieurs plateaux (10 ; 20 ; 30) moulés à partir de plastiques et respectivement pivotant sur ledit axe de pivot (40), plusieurs boîtes pour accessoires plates (12 ; 22 ; 32) moulées à partir de plastiques et portées chacune de manière détachable dans lesdits plateaux (10 ; 20 ; 30) ; une structure de positionnement adaptée pour fixer lesdites boîtes pour accessoires plates (12 ; 22 ; 32) auxdits plateaux (10 ; 20 ; 30), **caractérisée par le fait que** ladite structure de positionnement comprend plusieurs

- trous de localisation évidés (51) disposés au niveau d'un côté inférieur de chacune desdites boîtes pour accessoires plates (12 ; 22 ; 32), et plusieurs blocs de localisation (50) disposés au niveau d'un côté supérieur de chacun desdits plateaux (10 ; 20 ; 30) et adaptés pour rentrer en contact avec lesdits trous de localisation évidés (51), et **par le fait que** lesdits plateaux (10 ; 20 ; 30) ont chacun plusieurs trous traversants (13 ; 23 ; 33) disposés de manière symétrique près de deux côtés latéraux opposés des plateaux pour que l'utilisateur puisse insérer un doigt pour éloigner en poussant lesdites boîtes pour accessoires plates (12 ; 22 ; 32) desdits plateaux.
- 5
2. Casier de stockage selon la revendication 1, dans lequel le nombre de trous de localisation évidés (51) au niveau de chacune desdites boîtes pour accessoires plates (12 ; 22 ; 32) est égal au nombre de blocs de localisation (50) au niveau de chacun desdits plateaux (10 ; 20 ; 30).
- 10
3. Casier de stockage selon la revendication 1 ou la revendication 2, dans lequel lesdits trous de localisation évidés (51) sont respectivement disposés le long de trois des quatre côtés de chacune desdites boîtes pour accessoires plates (12 ; 22 ; 32) et couplés aux blocs de localisation correspondants (50) au niveau desdits plateaux (10 ; 20 ; 30).
- 15
4. Casier de stockage selon la revendication 1 ou la revendication 2, dans lequel lesdits trous de localisation évidés (51) sont respectivement disposés le long de deux côtés adjacents de chacune desdites boîtes pour accessoires plates (12 ; 22 ; 32) et couplés aux blocs de localisation correspondants (50) au niveau desdits plateaux (10 ; 20 ; 30).
- 20
5. Casier de stockage comprenant un axe de pivot (40), plusieurs plateaux (10 ; 20 ; 30) moulés à partir de plastiques et respectivement pivotant sur ledit axe de pivot (40), plusieurs boîtes pour accessoires plates (12 ; 22 ; 32) moulées à partir de plastiques et respectivement portées de manière détachable dans lesdits plateaux (10 ; 20 ; 30) ; une structure de positionnement adaptée pour fixer lesdites boîtes pour accessoires plates (12 ; 22 ; 32) auxdits plateaux (10 ; 20 ; 30), **caractérisée par le fait que** ladite structure de positionnement comprend plusieurs trous de localisation évidés (51) formés dans un côté inférieur de chacune desdites boîtes pour accessoires plates (12 ; 22 ; 32), et plusieurs blocs de localisation (50) respectivement formés de manière intégrale avec lesdits plateaux (10 ; 20 ; 30) le long des quatre côtés de la périphérie de chaque plateau (10 ; 20 ; 30) et adaptés pour rentrer en contact avec lesdits trous de localisation évidés (51), et **par le fait que** lesdits plateaux (10 ; 20 ; 30) ont chacun plusieurs trous traversants (13 ; 23 ; 33) dis-
- 25
- 30
- 35
- 40
- 45
- 50
- 55
- posés de manière symétrique près de deux côtés latéraux opposés de ceux-ci pour que l'utilisateur puisse insérer un doigt pour éloigner en poussant lesdites boîtes pour accessoires plates (12 ; 22 ; 32) desdits plateaux.
6. Casier de stockage selon la revendication 5, dans lequel le nombre de trous de localisation évidés (51) au niveau de chacune desdites boîtes pour accessoires plates (12 ; 22 ; 32) est égal au nombre de blocs de localisation (50) au niveau de chacun desdits plateaux (10 ; 20 ; 30).
7. Casier de stockage selon la revendication 5 ou la revendication 6, dans lequel lesdits trous de localisation évidés (51) sont respectivement disposés le long de trois des quatre côtés de chacune desdites boîtes pour accessoires plates (12 ; 22 ; 32) et couplés aux blocs de localisation correspondants (50) au niveau desdits plateaux (10 ; 20 ; 30).
8. Casier de stockage selon la revendication 5 ou la revendication 6, dans lequel les trous de localisation évidés (51) sont respectivement disposés le long de deux côtés adjacents de chacune desdites boîtes pour accessoires plates (12 ; 22 ; 32) et couplés aux blocs de localisation correspondants (50) au niveau desdits plateaux (10 ; 20 ; 30).

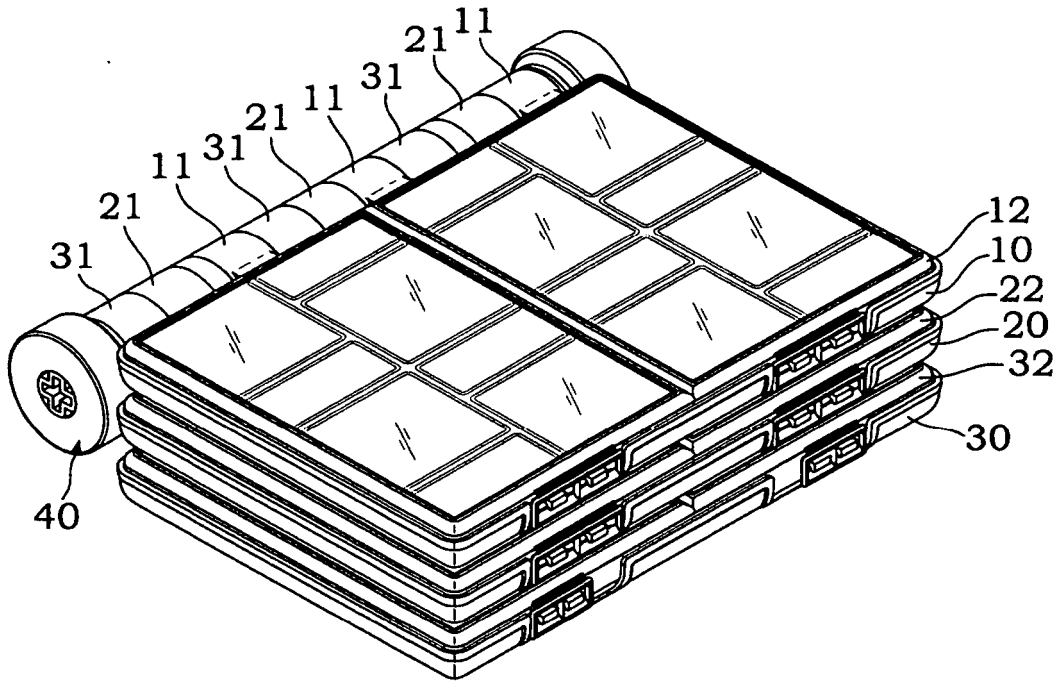

FIG. 1

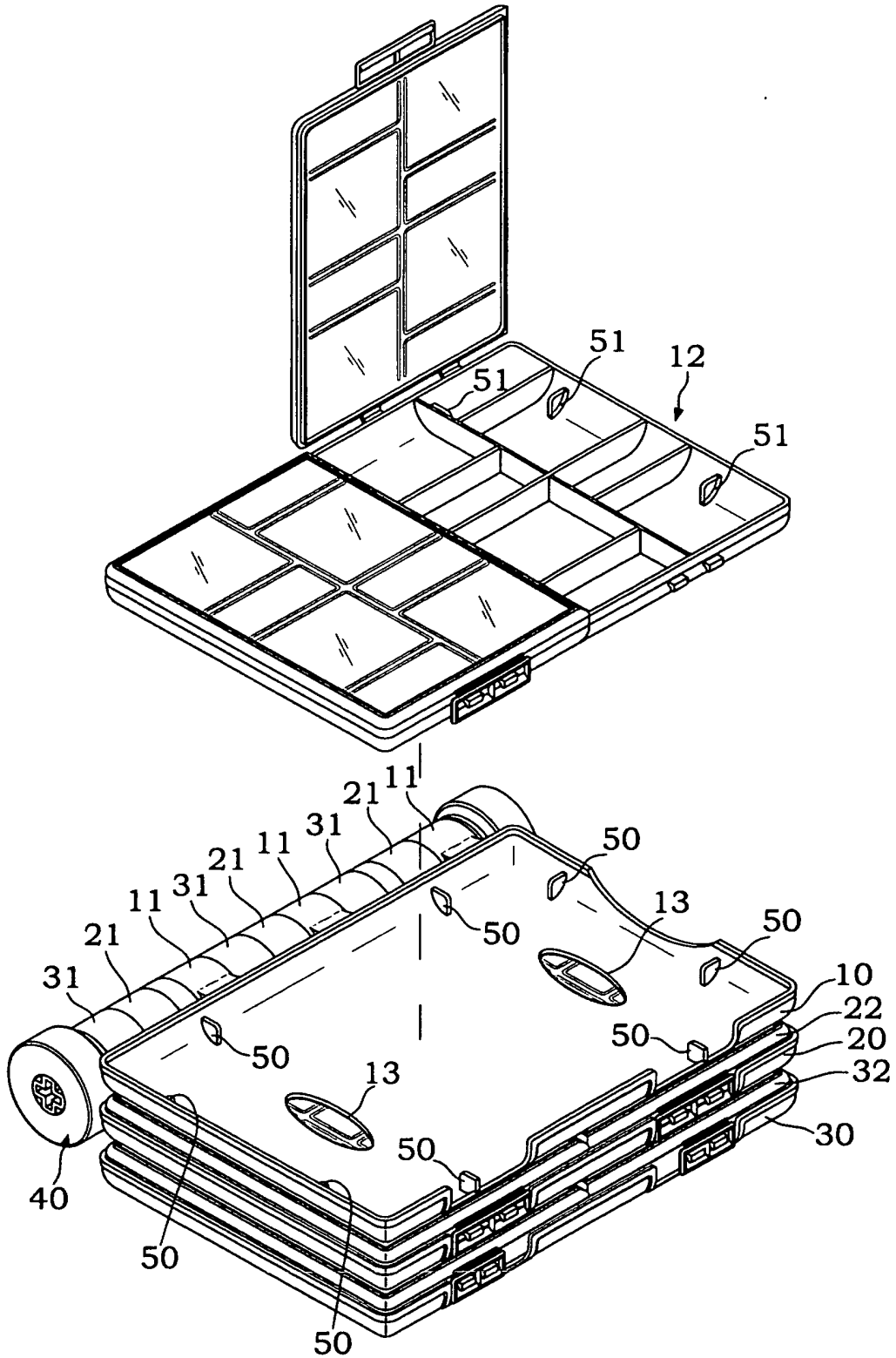

FIG.2

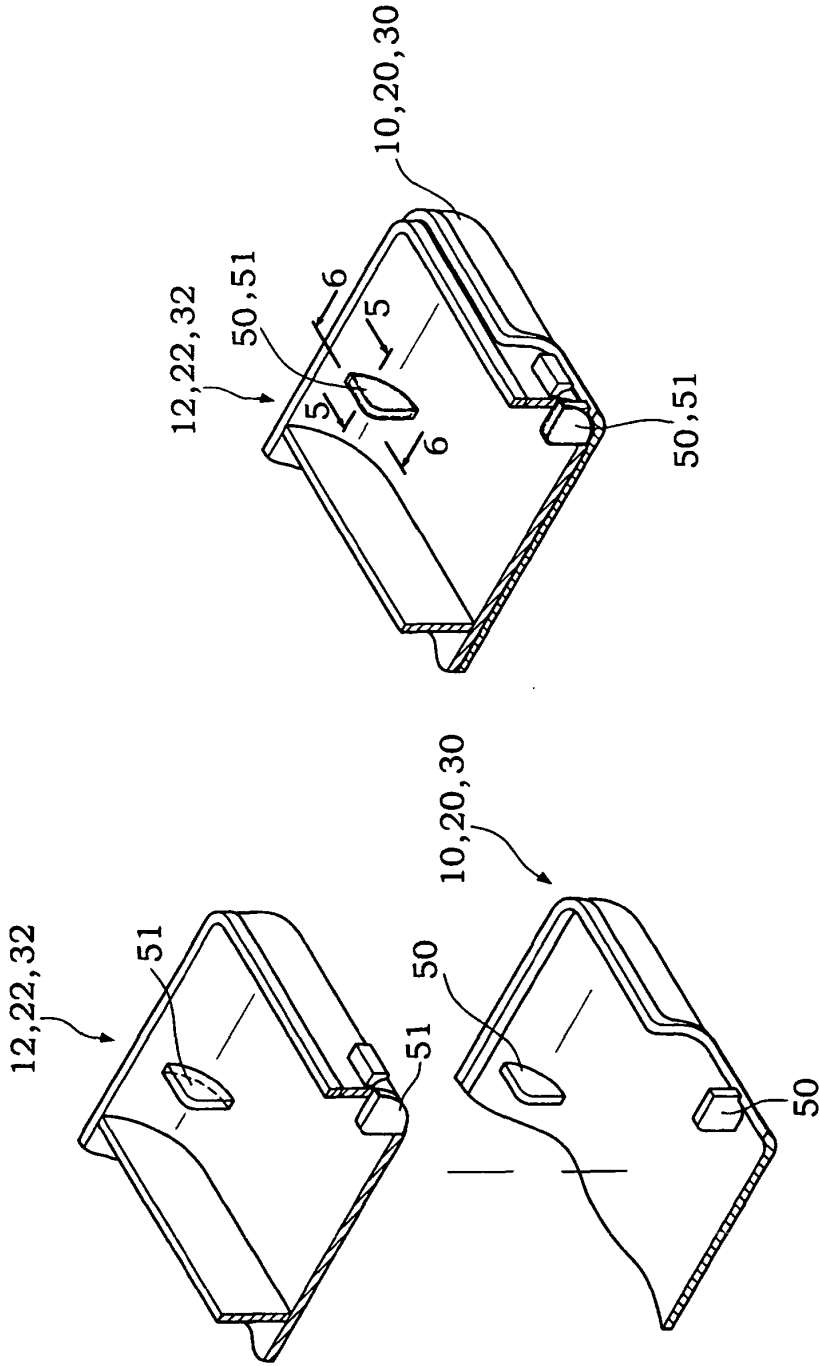

FIG. 4

FIG. 3

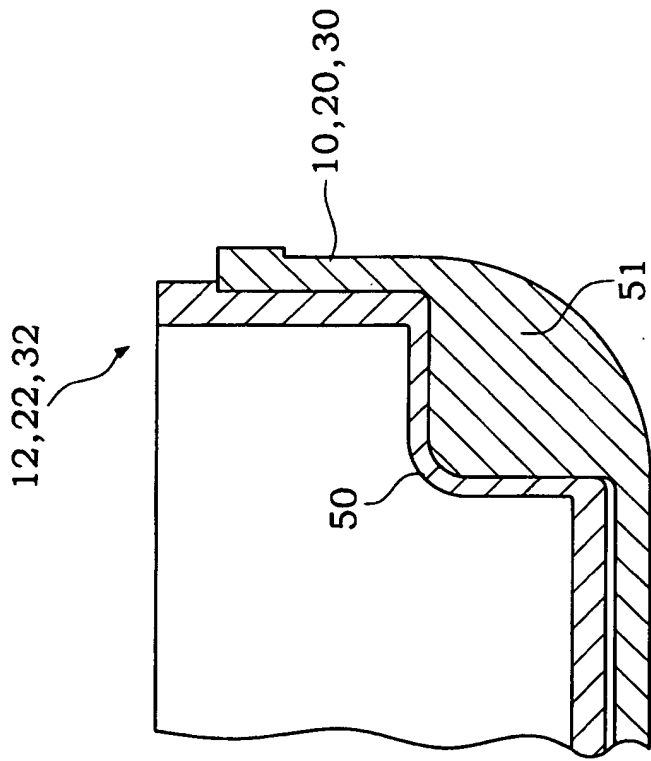

FIG.6

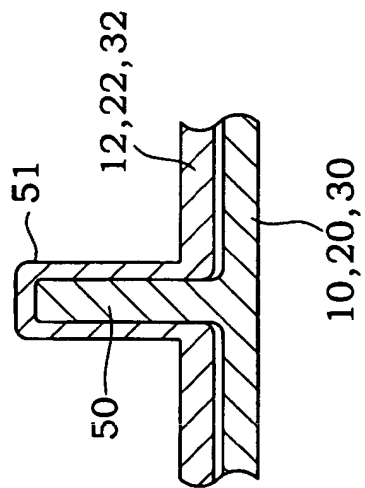

FIG.5

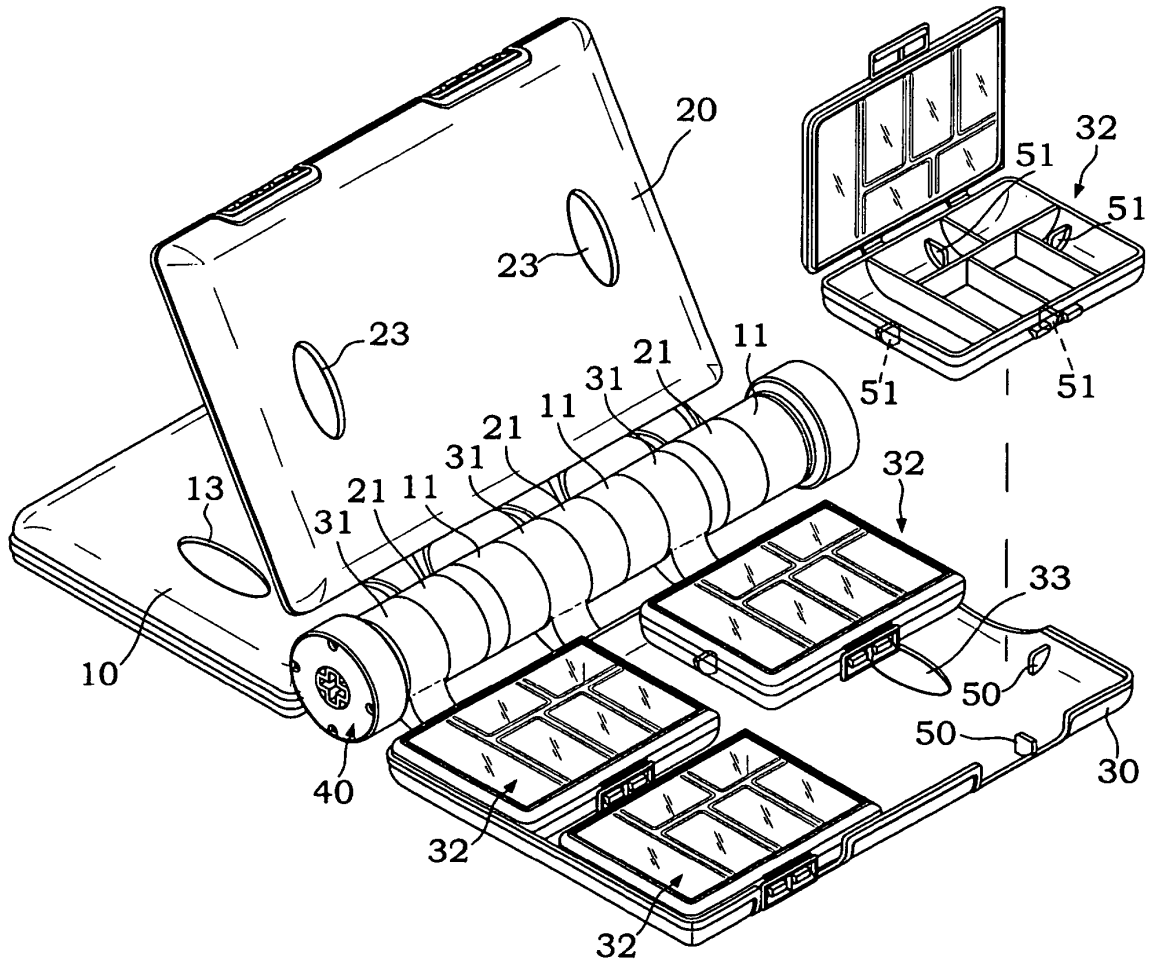

FIG. 8

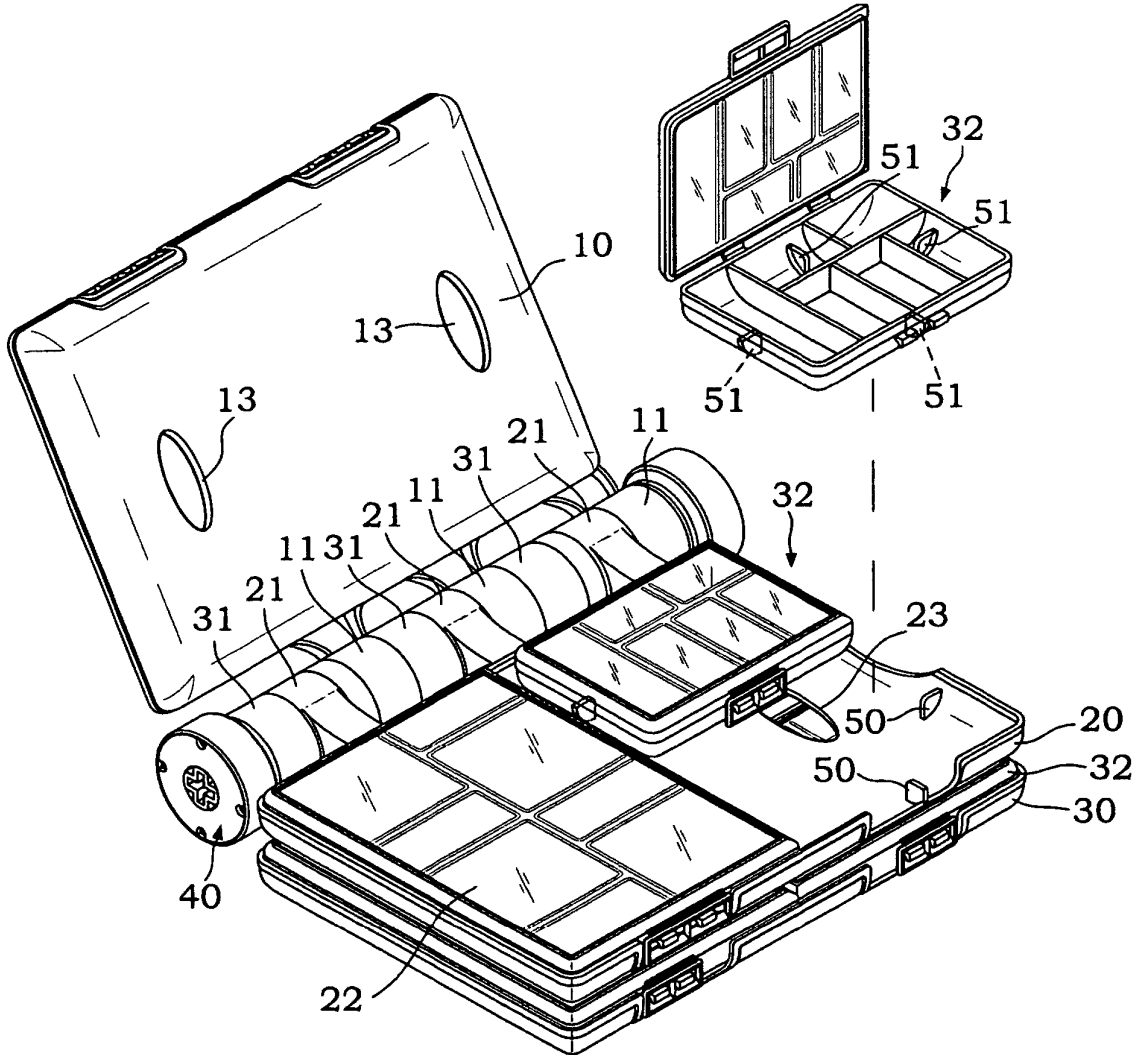

FIG. 9

REFERENCES CITED IN THE DESCRIPTION

This list of references cited by the applicant is for the reader's convenience only. It does not form part of the European patent document. Even though great care has been taken in compiling the references, errors or omissions cannot be excluded and the EPO disclaims all liability in this regard.

Patent documents cited in the description

- EP 1364753 A1 [0002]
- EP 1364753 A [0005]