

(19)
(12)

(KR)
(A)

(51) 。 Int. Cl. ⁷
A44B 19/36

(11)
(43)

2002 - 0032002
2002 05 03

(21) 10 - 2000 - 0062836
(22) 2000 10 25

(71) () 1가 129 - 22 B1

(72) 1가 129 - 22 B1

:

(54)

가 (44a) (4') 가 가 (11)
 , (10); (10) (20) , (10) (12) (30);
 (13 37) , (12) 가 (30)
 (絲)가 , 가 , 가 , 가
 , 가 , 가 , 가
 가 .

1
2 1
3 1
4 1
5
6
7
8 1
9 1
10 2
11
12 11
13
14
15

< >

1 : 2 :
3 : 4, 4' :
5 :
10 : 11 :
12 : 13 :
14 : 15 :
16, 16' : 17 :
18 :
20 : PE 21 : PE

22 : 23 :

24 : 25 :

26 : 가 27 : 가

28 :

30 : 31 :

32 : 33 : PE

34 : 35 :

36 : 37 :

38 : 38a :

39 : 39' :

41 : 42 :

43 : 44 :

44a :

가 가 , , 가
 , 2000 - 20707 " " ,
 가 , , 가
 , , 가 , 9 , 가 ,
 , 가 가 가 ,
 , 1999 - 2637

. , 10 , , UV (6) UV () , , 가 , , .
 . , 가 , 가 , 가 .
 가 , (3) , (3) (6) (4')가 (4') (2)
 가 , (4') (3) (teeth) (6) , .
 , (4') 가 , (3)가 가 .
 , 11 12 .
 11 , , 12 , 11 .
 11 (6) , 가 (2) , 가 (1) (6) (teeth)가 가 , .
 , (2) (3)가 , (3) , 가 , 가 .
 , 가 (4')가 , 가 .
 , 3 .
 , 가 , 가 , 가 .
 , 가 (1) (6) 가 , (

13 14 가 13 14 가

(10); (44a) (4') (12) (11) (30); (10); (10) (20) (30); (12) (30) (13) 37 가 (絲)가

(30) 가 (31) (20) (絲) (35) (37)

(11) (10) (13) (13) 가

(35) (31) 가 (32) 가 (33) (31) (20) (絲) (36)

(11) (44a) (4') (10) (10) (30) (20) (11) (30)

가

1
3 1 , 4 1 , 2 1 ,

1 ,
30) , 가 PE (10) , (20) , (41, 42, 43) (

1 3 , (41) (10)
(42), (43)가 .

18) (10) , 1 3 , (18) (

(13) (11)가 (15) , (18) .

(13) (11) (17) .
(11) (20) (15)

(11) (12) , " " " Ultra Sonic"
가 . 16,16' , 14

PE (20) , 1 2 , (41) (30)
, PE (28) 가, (23) PE 2가 (24)
, 가 (26) (30) . PE (22)
, (25) . PE 27 가 .

(30) , 1 2 , PE (20) (41)
(11) .

4 , 가 PE PE (35),
(31), (12) (38) .
(39) (39') ,

(36)가 (12) , (41)
(PE) .

39) " IL SHIN TECH" (37) " IF 32A - S10" (

(31) 4 6 , 가
 (32) , (32)
 (2 - 3) (34)
 , (36)가
 (32) PE (33) , PE (33)
 (34) PE 가 (26) . 31a 가

가 4 5 , (31)
 가 , (31a) (34)
 (36)가 ,
 , 38a 가 ,

8 A - A' 가 7 , 8 PE 가 7 PE
 (33) , (32)
 (36)가 (31a) (11)가 (35)가 (39) ,
 (34) (34) PE (21)
 (44) (44a) ,

가 , 가 15 , (2) (6)
 , (3) (4')
 가 ,

(3)가 (4') 가 , 15 가 ,

가 , 가

가 , 가 ,

PE 가 (13, 39) , (39)가 ,

가 , 가 , UV 가 가 가

(57)

1.

(10); (44a) (4') (12) (11)
(10) (30);
(20) ,
(10) (12) 가 (30) (13 37)
(絲)가

2.

(30) , 가 (31)
(20) (絲)
(35) ,
(37)

3.

1 , (10) , (11)
(13) , (13) 가

4.

1 2 , (31) 가 (32) 가 (33) ,
(35) (31) (36) (20) (絲)
(36)

5.

(10) (44a) (4') (11) (10) ,
 (30) ,
 (20)

(30) ;

(11) ;

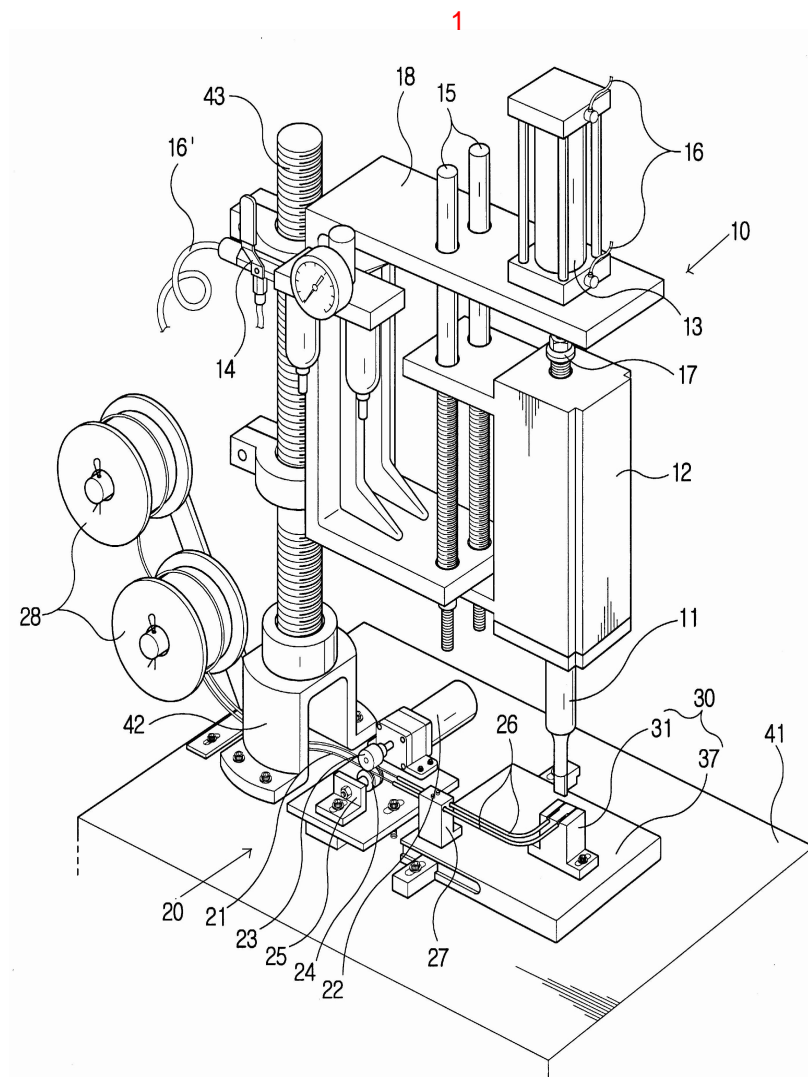

2

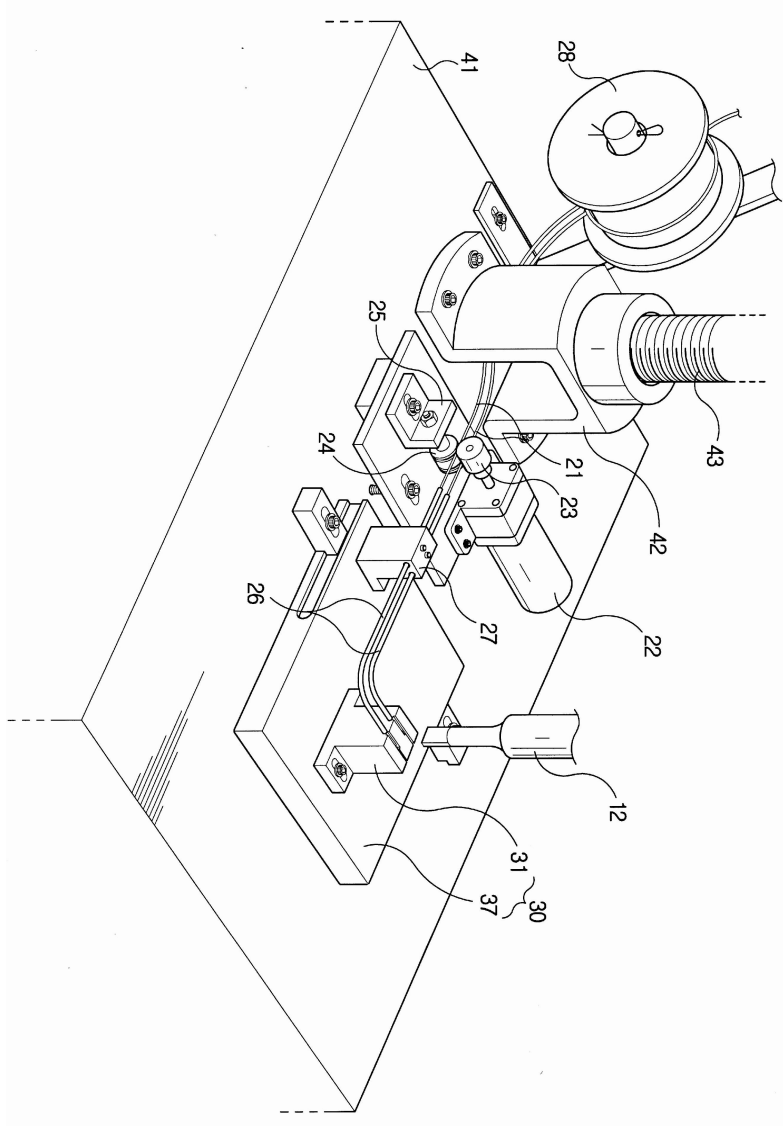

3

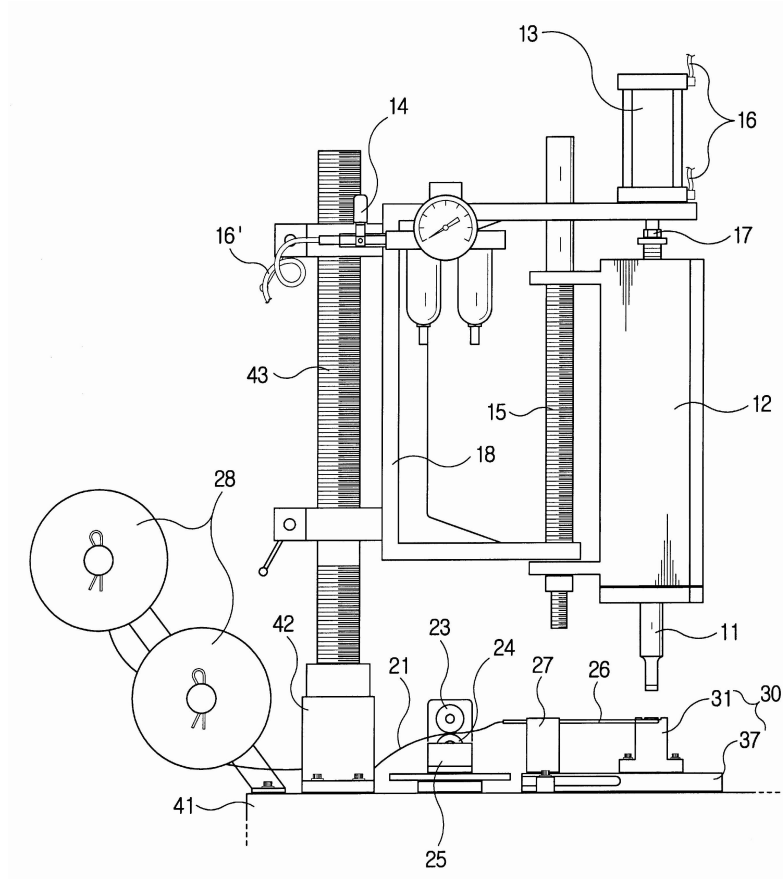

4

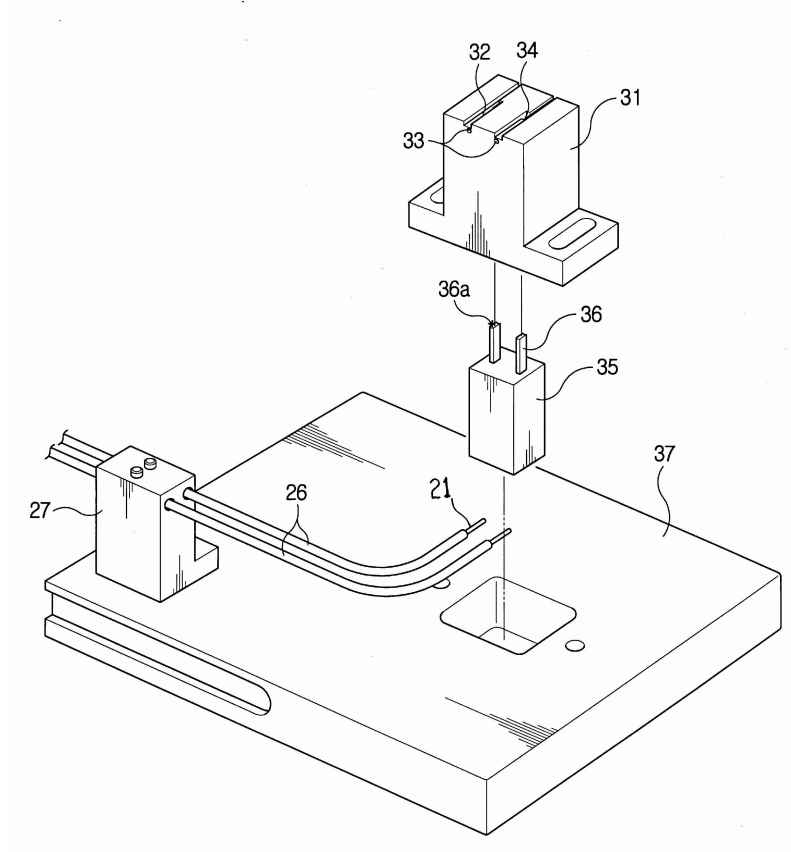

5

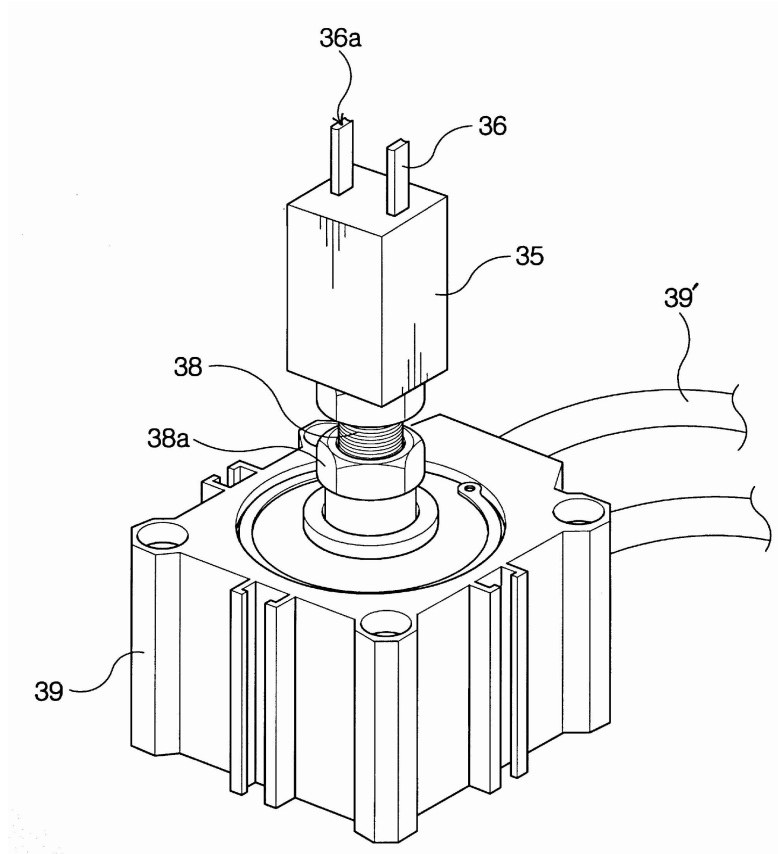

6

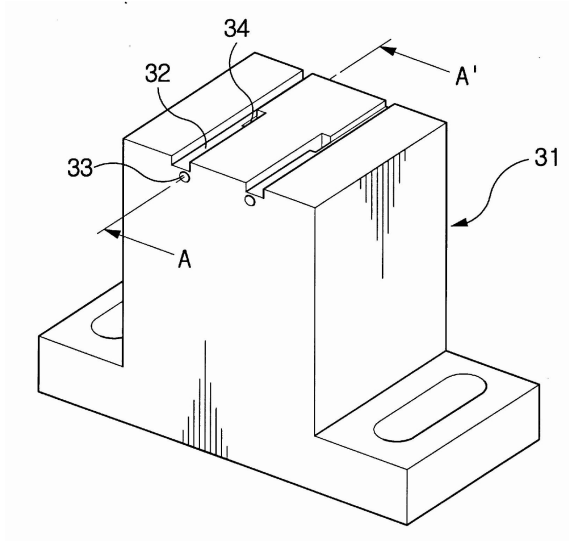

7

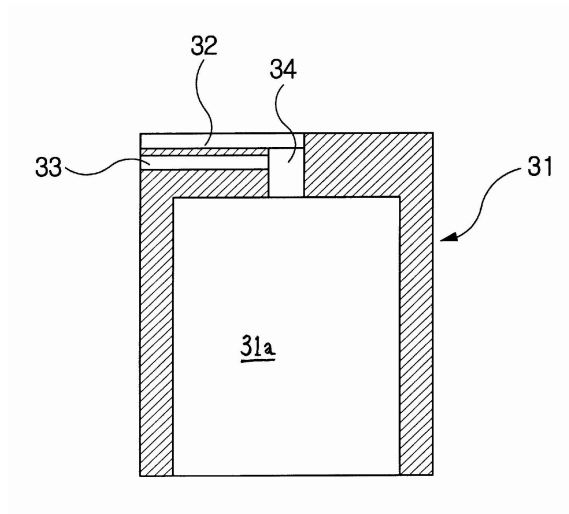

8

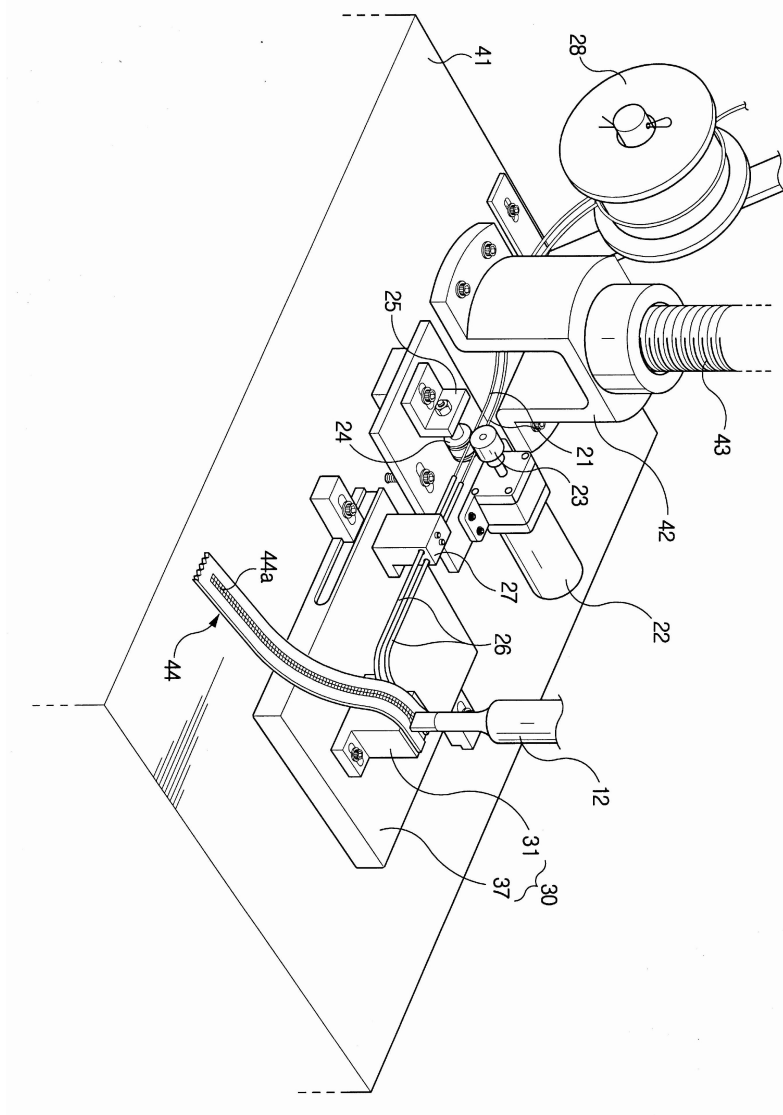

9

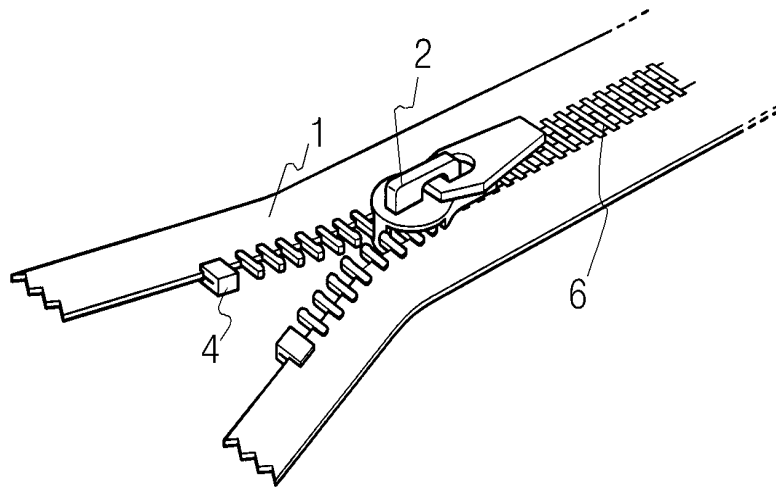

10

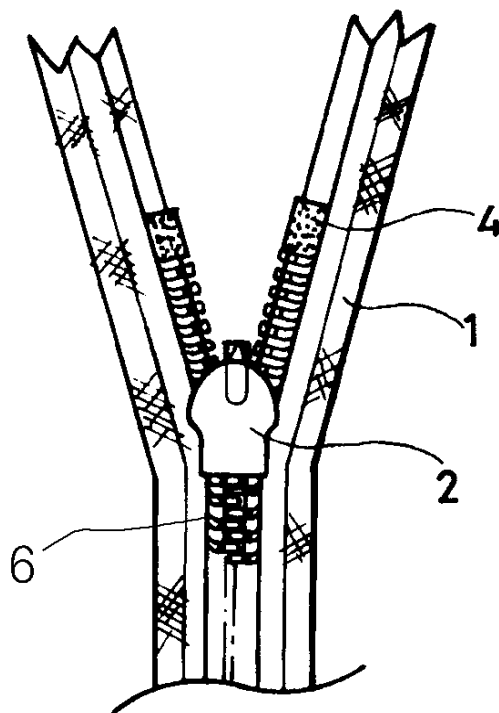

11

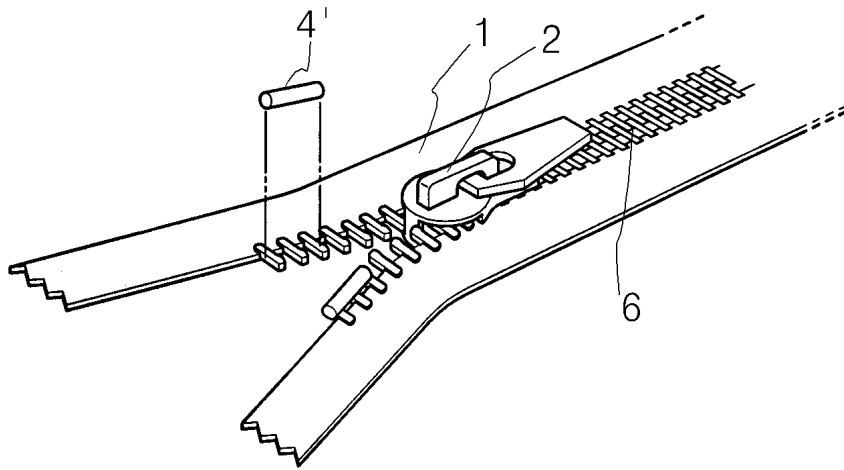

12

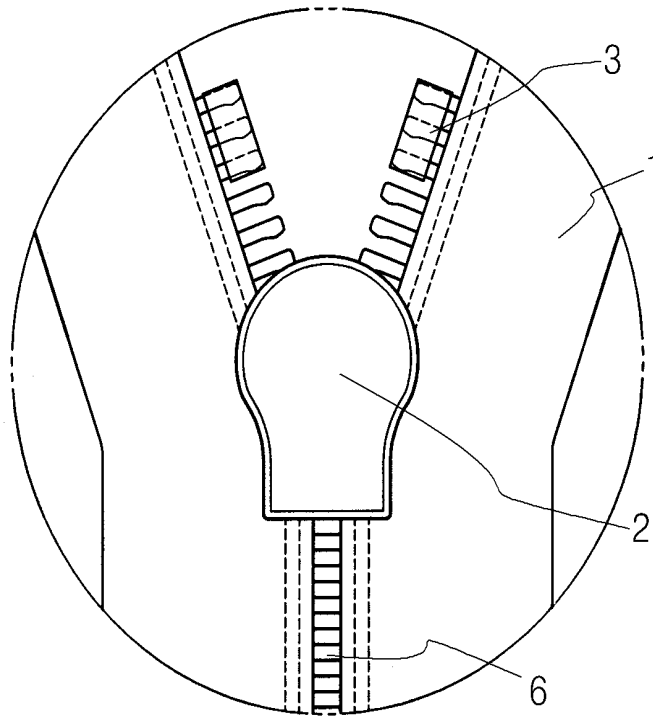

13



14



15

