

(19) World Intellectual Property Organization
International Bureau



(43) International Publication Date
11 September 2009 (11.09.2009)

(10) International Publication Number
WO 2009/111094 A1

- (51) International Patent Classification:
B25C 5/06 (2006.01)
- (21) International Application Number:
PCT/US2009/030410
- (22) International Filing Date:
8 January 2009 (08.01.2009)
- (25) Filing Language: English
- (26) Publication Language: English
- (30) Priority Data:
61/034,752 7 March 2008 (07.03.2008) US
- (71) Applicant (for all designated States except US): **ARROW FASTENER COMPANY, INC.** [US/US]; 271 Mayhill Street, Saddle Brook, NJ 07663 (US).
- (72) Inventors; and
- (75) Inventors/Applicants (for US only): **MANDEL, Steven, J.** [US/US]; 65 West 96th Street, Apt. 10F, New York, NY 10025 (US). **SUN, Pei-Chang;** 216, Alley 89, Lane 112, Jhongcing Road, Beitun District, Taichung City, 406 (TW).
- (74) Agents: **MEE, Brendan** et al.; Fitzpatrick Cella, Harper & Scinto, 30 Rockefeller Plaza, New York, NY 10112-3800 (US).

(81) Designated States (unless otherwise indicated, for every kind of national protection available): AE, AG, AL, AM, AO, AT, AU, AZ, BA, BB, BG, BH, BR, BW, BY, BZ, CA, CH, CN, CO, CR, CU, CZ, DE, DK, DM, DO, DZ, EC, EE, EG, ES, FI, GB, GD, GE, GH, GM, GT, HN, HR, HU, ID, IL, IN, IS, JP, KE, KG, KM, KN, KP, KR, KZ, LA, LC, LK, LR, LS, LT, LU, LY, MA, MD, ME, MG, MK, MN, MW, MX, MY, MZ, NA, NG, NI, NO, NZ, OM, PG, PH, PL, PT, RO, RS, RU, SC, SD, SE, SG, SK, SL, SM, ST, SV, SY, TJ, TM, TN, TR, TT, TZ, UA, UG, US, UZ, VC, VN, ZA, ZM, ZW.

(84) Designated States (unless otherwise indicated, for every kind of regional protection available): ARIPO (BW, GH, GM, KE, LS, MW, MZ, NA, SD, SL, SZ, TZ, UG, ZM, ZW), Eurasian (AM, AZ, BY, KG, KZ, MD, RU, TJ, TM), European (AT, BE, BG, CH, CY, CZ, DE, DK, EE, ES, FI, FR, GB, GR, HR, HU, IE, IS, IT, LT, LU, LV, MC, MK, MT, NL, NO, PL, PT, RO, SE, SI, SK, TR), OAPI (BF, BJ, CF, CG, CI, CM, GA, GN, GQ, GW, ML, MR, NE, SN, TD, TG).

Published:

— with international search report (Art. 21(3))

(54) Title: WIRE GUIDE FOR AN AUTOMATIC STAPLE GUN

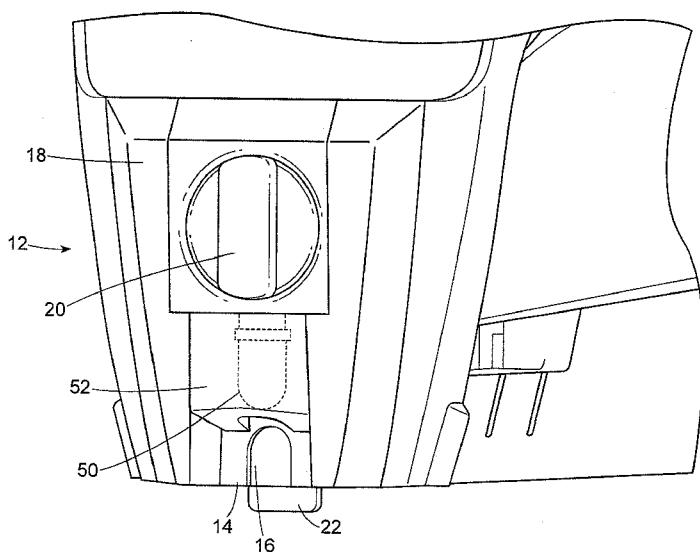

FIG. 2

(57) Abstract: A wire guide apparatus for a powered staple gun (10) is adapted to be housed in a low-profile housing (18) at the front end of the staple gun, forward of the safety (22) and staple driver.

WO 2009/111094 A1

- 1 -

TITLE

WIRE GUIDE FOR AN AUTOMATIC STAPLE GUN

BACKGROUND OF THE INVENTION

Field of the Invention

[0001] The invention is directed to the field of automatic staple guns, and more particularly to a wire guide element for positioning a staple in the gun with respect to a wire or cable to be stapled.

DESCRIPTION OF RELATED ART

[0002] Staple guns are well known hand-held tools adapted to drive staples into a workpiece. Arrow Fastener Company manufactures and sells numerous models of such devices, including the non-powered staple gun sold under the T-50® brand name, and more recently introduced powered models, such as the cordless CT-50™.

[0003] It is known to provide a wire guide for a staple gun, as disclosed for example in U.S. Patent No. 5,884,829, assigned to the Arrow Fastener Company and incorporated herein by reference. A wire guide is an element having a surface that fits around a wire or cable, positioning the staple gun so that the staple is driven reliably over the wire or cable to attach it to the work piece. Surfaces on either side of the wire or cable are typically positioned against the surface to be stapled.

- 2 -

[0004] As staple gun technology has advanced, a number of desirable features have been added. An LED positioned near the staple driver and adapted to directly illuminate the surface being stapled is very popular. It is also known to equip staple guns with passive safety features. In the CT 50TM by Arrow Fastener Company, for example, the safety element is a planar vertically oriented element that protrudes from the bottom of the gun in front of the driver. The planar element actuates a switch, so that the gun can fire only when the safety is fully depressed, *i.e.*, when the bottom of the gun is positioned against a surface to be stapled.

[0005] Both the LED and safety are advantageously positioned in front of the staple driver, so as not to interfere with the operation of the gun, and especially with the operation of the staple driver. To provide a wire guide in combination with these elements poses a technical challenge because the available space in front of the staple driver is limited.

[0006] Thus, one object of the invention is to provide a wire guide for a staple gun in a low profile housing at the front end thereof, that can be retracted by the user and which can be combined with other elements, such as an LED and a safety, in a space-saving manner.

BRIEF SUMMARY OF THE INVENTION

[0007] In one aspect, the invention is a wire guide apparatus provided on a staple gun having a staple driver at a front end thereof (such as, without limitation, the CT-50TM model made by Arrow Fastener Corporation). A housing for the wire guide is positioned forward of the staple driver. The housing houses a cam switch, a cam shaft and a cam, and the cam switch can be moved to rotate the cam. A substantially planar wire guide in the housing has a first cutout adapted to be positioned over a wire or cable, and a second cutout adapted to receive the cam. The cam is positioned to be rotated within the second cutout to move the wire guide between a first position, in which the first cutout is not extended from the staple gun and a second position, in which the first cutout is extended from the staple gun.

- 3 -

[0008] In preferred embodiments, the staple gun is provided with a substantially planar safety element having an aperture through which the cam shaft passes, the aperture being elongated so that the safety element can slide in the vertical direction in the housing.

[0009] In still more preferred embodiments, the housing is provided with a light emitting diode.

BRIEF DESCRIPTION OF THE DRAWINGS

[0010] **Fig. 1** is a perspective view of a staple gun incorporating a wire guide apparatus according to the invention.

[0011] **Fig. 2** is a detail view of the wire guide housing.

[0012] **Fig. 3** is a detail view of the wire guide housing with the wire guide in the extended position.

[0013] **Fig. 4** is a detail view of internal elements of the wire guide camming mechanism.

[0014] **Fig. 5** is a detail view of internal elements of the wire guide camming mechanism in the extended and locked position.

DETAILED DESCRIPTION OF THE INVENTION

[0015] Unless stated otherwise, directions are used herein with reference to the normal orientation of the staple gun. Thus, the handle is at the top of the device, and the direction toward the top is "up." The staple driver (not shown) is oriented vertically, located toward the "front" of the gun; staples come out of the "bottom" of the staple gun, and the direction toward the bottom is "down," etc.

[0016] In the embodiment shown in **Fig. 1**, the staple gun **10** includes insert **12**, located at the front end of the staple gun at the bottom. The staple driver, sometimes referred to as the "knife" (not shown), is a vertical element located behind the insert that drives the staples out of the gun when the trigger is actuated.

- 4 -

[0017] As seen in the detail view of **Fig. 2**, insert **12** includes a housing **18**, which may be provided with slots to guide a wire guide **14** and safety element **22**. The housing also includes space for cam switch **20**.

[0018] The cam switch may be any shape provided that it can be configured to move wire guide **14**. In a preferred embodiment, at least a portion of the cam switch is arcuately shaped, and the cam is seated in a correspondingly shaped arcuate recess in the housing. For example, the switch can be circular and seated in a circular recess, as shown in **Fig. 2**.

[0019] In the embodiment shown, the cam switch is rotatable between a first position and a second position, corresponding to respective first and second positions of wire guide **14**, so that the wire guide is either not extended from the bottom of the staple gun, as shown in **Fig. 2**, or extended from the bottom of the staple gun, and ready to be used. This enables convenient use of the staple gun without the wire guide, such as with nails (typically 5/8" nails), or with staples, in a context where it is not desired to staple cable or wire. In those instances, the wire guide is set to a retracted position.

[0020] The housing may have an open back and a central channel on the front of the housing to receive the cam switch **20** and a sub housing **52** holding an LED **50** in a compact low-profile manner. "Low profile" in this context means less than 25 mm, preferably less than 20 mm and most preferably less than 15 mm total height of the housing from back to front.

[0021] The wire guide element **14** is preferably planar so that it can be accommodated in a low profile housing. The wire guide comprises a first cutout **36** (shown in **Fig. 4**) with an open end adapted to be positioned over a wire or cable when in use, and a second cutout **32** adapted to receive the cam **28**. The second cutout has a closed surface **34** (seen in **Fig. 4**) on one side of the cam which prevents rotation of the cam past surface **34** in either clockwise or counter-clockwise directions, while on the opposite side of the cam, the second cutout **32** has room to permit rotation of the cam **28**. In the embodiment shown, the side of the second cutout opposite the closed side is open, and the cam can be rotated a little more than 180 degrees from the first position to the second position.

- 5 -

[0022] The closed surface **34** of the second cutout may be provided with rounded corners so that the cutout is slightly wider at the closed end than at the open end. This facilitates positioning the bearing surface **30** of the cam in the corners of the second cutout to perform a locking function as described below.

[0023] The operation of a cam mechanism for a wire guide according to the invention is illustrated in connection with **Fig. 4**. In **Fig. 4**, the cam switch has been removed to reveal cam shaft **24**, spring **26** and cam **28**, which are assembled on back plate **120**. The cam may have any shape suitable to the purpose, including the ovoid shape shown in the preferred embodiment of **Fig. 4**. In the retracted or first position, bearing surface **30** of the cam **28**, is urged against the top surface of the second cutout **32**. To lock the wire guide in the first (retracted) position, the cam is rotated a little past the longitudinal axis of the wire guide, so that the longitudinal axis of the cam forms a small angle with respect to the longitudinal axis of the wire guide **14**, inclining slightly toward the closed side of the second cutout. A similar locking functionality is obtained in the second (extended) position of the wire guide, where the cam is rotated a little more than 180 degrees, so that bearing surface **30** of the cam is urged against the bottom surface of the second cutout. By lodging the bearing surface **30** of the cam in the corner of the cutout, so that the longitudinal axis of the cam is at an angle with respect to a longitudinal axis of the wire guide, the wire guide cannot be moved by applying force in the direction of arrow F, unless the cam is moved again by moving cam switch **20**. This is shown best in **Fig. 5**.

[0024] The locking mechanism is improved by widening the corners of the closed surface **34** in the second cutout, such as by rounding the corners. The dimensions of the second cutout are determined by how large a cam is required to make the wire guide protrude from the staple gun by the desired amount in the second position. Although not critical, the vertical height of the second cutout may be in a range of about 8.0 mm to about 11.0 mm, and the distance between the top and bottom walls at the closed end, *i.e.*, at the widest point, may be about 0.1 mm to about 0.5 mm larger than the distance at the opposite, or open, side of the second cutout.

- 6 -

[0025] The first cutout **36** may be formed with prongs **38** defining opposite sides of the first cutout. The distance between the two prongs defining the first cutout is not particularly critical, and may be, for example, in a range of about 6.0 mm to about 8.0 mm. In a working embodiment, a width of 7.0 mm was found to be suitable for this purpose. Likewise, the distance from the top of the cutout to the bottom ends of the prongs is not limited. This distance may conveniently be in a range of about 5.0 to 7.0 mm, for example 6.2 mm. The top of the cutout may be any shape, such as arcuate shape. In the Figures, the top of the cutout is essentially in the shape of a semicircle. The staples ordinarily used with the CT-50TM made by the Arrow Fastener Company will also be used with a model adapted with the wire guide according to the invention, and the size of the first cutout may be designed accordingly.

[0026] In embodiments, the staple gun may be provided with a safety element **22** which is operatively connected to elements in the body of the gun in a known manner (not shown) so that the gun cannot fire unless the safety is depressed. In order to accommodate operation of the safety **22** with a wire guide and housing as described herein, safety **22** is provided with an aperture **44** through which cam shaft passes. The aperture is somewhat elongated, allowing the safety element to move up and down without affecting the wire guide. (Only a portion of aperture **44** is seen in **Fig. 4** and **Fig. 5**, because the view is obscured by the wire guide.)

[0027] **Fig. 2** depicts a preferred embodiment in which housing **18** is provided with a central channel which houses the cam switch **20**, as well as LED sub housing **52**, including LED **50**, as well as accommodating the wire guide and cam elements described above. All of these elements can be provided in a low profile format, having a height less than 20 mm, preferably less than 15 mm, which permits the safety **22**, the LED **50** and the wire guide **14** all to be positioned in close proximity to the staple driver.

[0028] The above description of the preferred embodiments, in connection with the drawings, is for illustration purposes, and is not to be deemed limiting of the invention, which is defined by the appended claims.

- 7 -

WHAT IS CLAIMED IS:

1. A wire guide apparatus for a staple gun having a staple driver at a front end thereof, the apparatus comprising:

a housing positioned on the front end of the staple gun forward of the staple driver;

the housing holding a cam switch, a cam shaft and a cam, the cam switch being movable to rotate the cam;

a substantially planar wire guide having a first cutout adapted to be positioned over a wire or cable and a second cutout adapted to receive the cam;

wherein the cam is movable within the second cutout to move the wire guide from a first position, in which the first cutout is not extended from the staple gun, to a second position in which the first cutout is extended from the staple gun.

2. The wire guide apparatus of claim 1, wherein the staple gun is provided with a substantially planar safety element having an aperture through which the cam shaft passes, the aperture being elongated so that the safety element can slide in the housing without affecting the wire guide.

3. The wire guide apparatus of claim 1,

wherein at least a portion of the cam switch has an arcuately shaped portion received in a correspondingly shaped arcuate recess in the housing;

wherein the cam switch is rotatable between a first position, in which a bearing surface of the cam is urged against an upper surface of the second cutout in the wire guide, and a second position, in which the bearing surface of the cam is urged against a lower surfaces of the second cutout in the wire guide;

wherein said first and second positions of the cam switch and cam correspond to the first and second positions of the wire guide; and

wherein, in the first position and the second position, the longitudinal axis of the cam is at an angle with respect to a longitudinal axis of the wire guide to lock the wire guide in the first position and the second position.

- 8 -

4. The wire guide apparatus of claim 1, further comprising a light emitting diode positioned forward of the wire guide.

5. The wire guide apparatus of claim 1, wherein the housing has an open back, a forward slot to receive the wire guide, a rear slot to receive a planar safety element, and a central channel on the front of the housing to receive the cam switch, an LED and an LED subhousing in a low profile manner.



FIG. 1

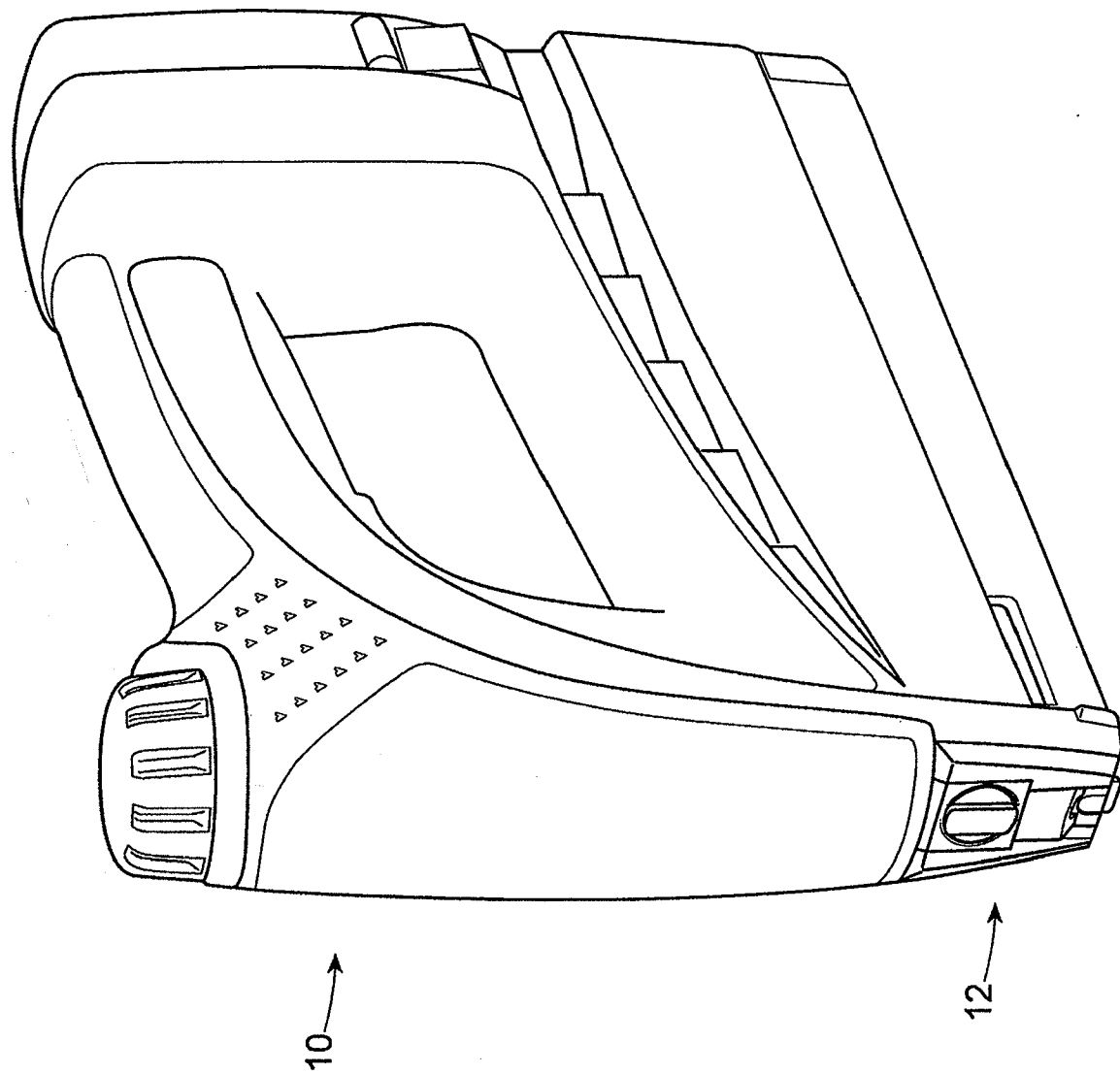

FIG. 2

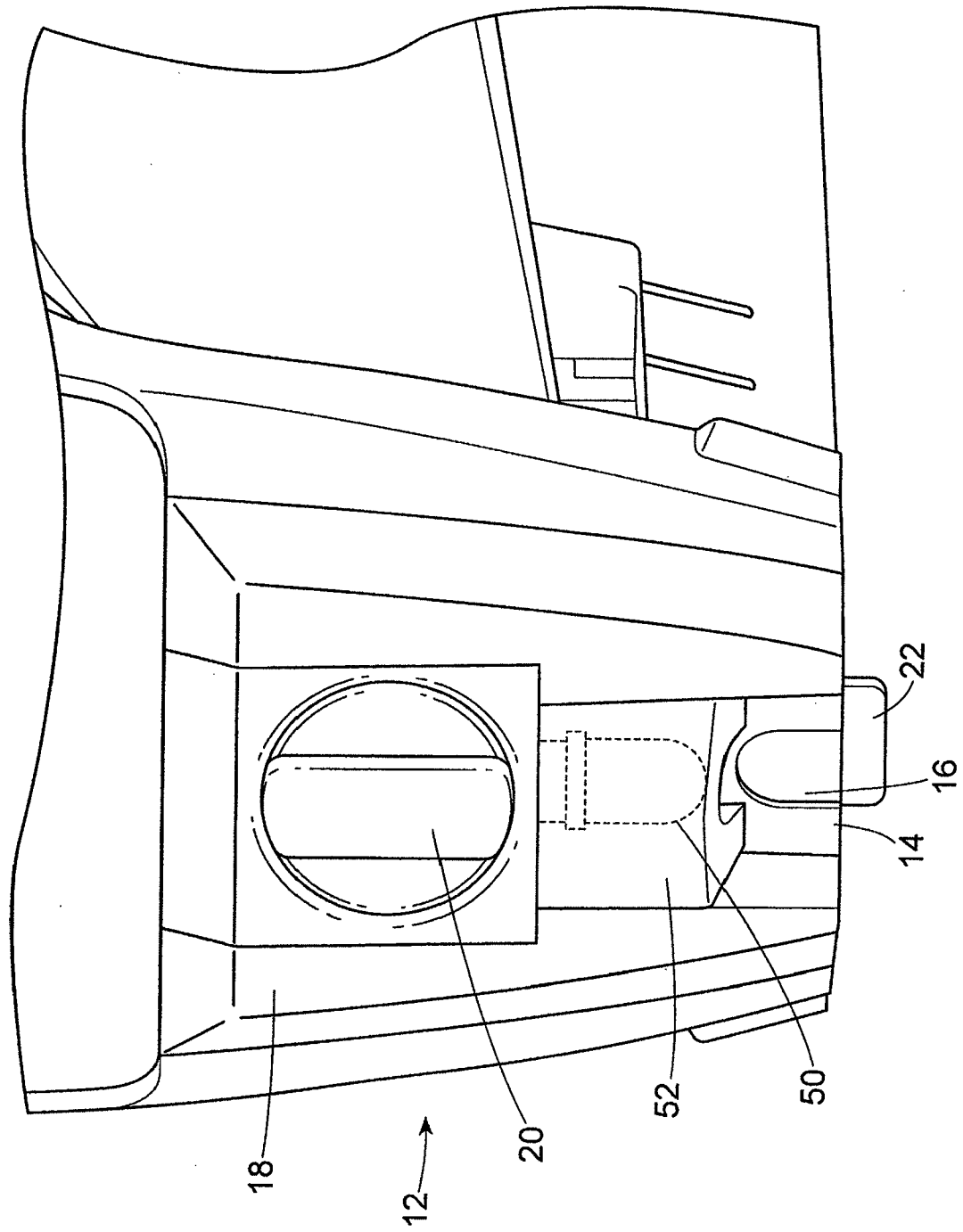



FIG. 3

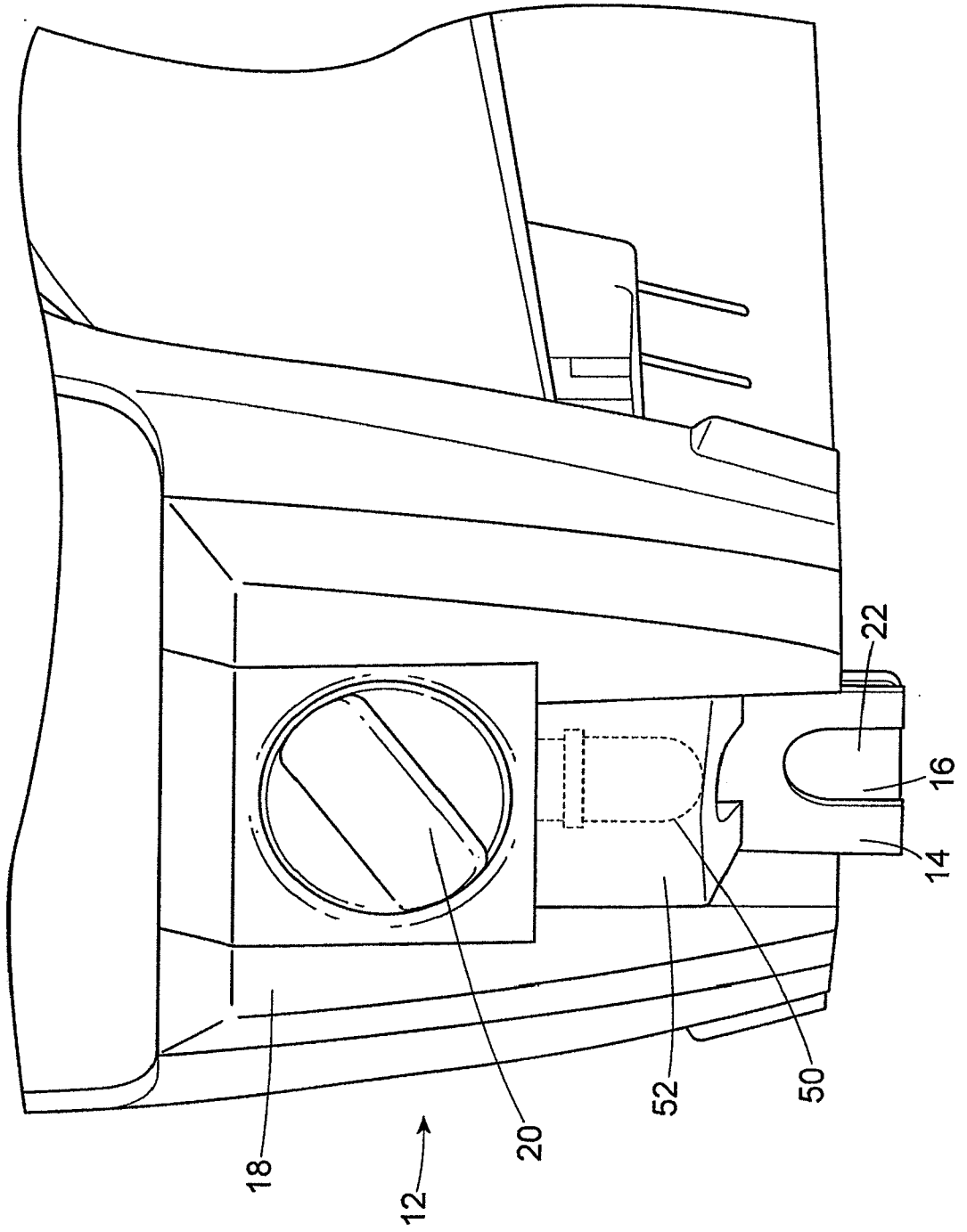

FIG. 5

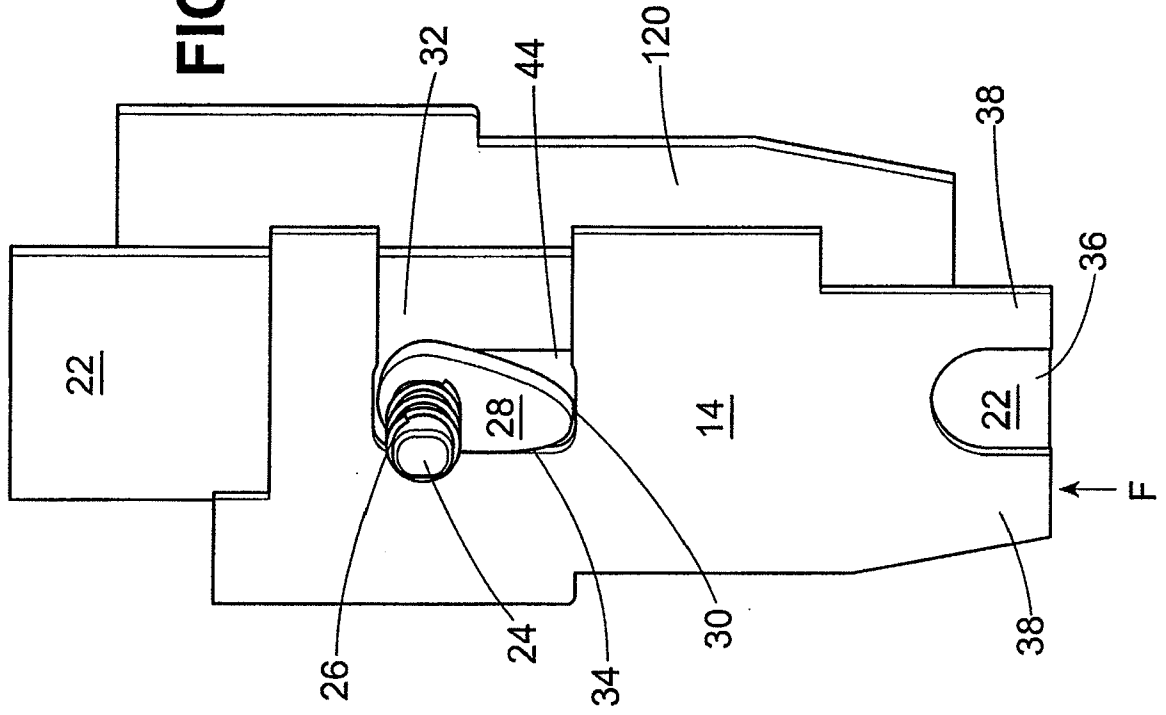
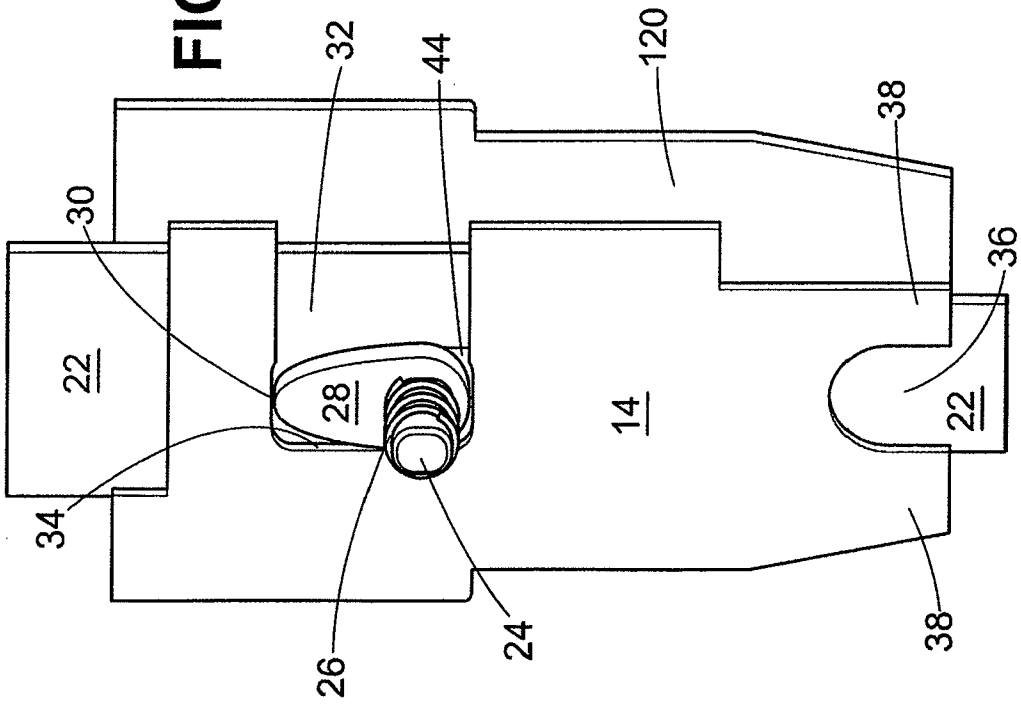

FIG. 4



INTERNATIONAL SEARCH REPORT

International application No

PCT/US2009/030410

A. CLASSIFICATION OF SUBJECT MATTER INV. B25C5/06		
According to International Patent Classification (IPC) or to both national classification and IPC		
B. FIELDS SEARCHED		
Minimum documentation searched (classification system followed by classification symbols) B25C		
Documentation searched other than minimum documentation to the extent that such documents are included in the fields searched		
Electronic data base consulted during the international search (name of data base and, where practical, search terms used) EPO-Internal		
C. DOCUMENTS CONSIDERED TO BE RELEVANT		
Category*	Citation of document, with indication, where appropriate, of the relevant passages	Relevant to claim No.
X	EP 1 095 740 A (WORKTOOLS INC [US]) 2 May 2001 (2001-05-02) paragraphs [0007] - [0024]; figures 1-8	1-5
X	US 2007/039994 A1 (PELLETIER THOMAS [US] ET AL) 22 February 2007 (2007-02-22) paragraphs [0027] - [0032]; figures 1A-4B	1-5
A	US 4 552 296 A (SHENG WANG [TW]) 12 November 1985 (1985-11-12) columns 2-4; figures 1,11	1-5
<input type="checkbox"/> Further documents are listed in the continuation of Box C. <input checked="" type="checkbox"/> See patent family annex.		
* Special categories of cited documents :		
A document defining the general state of the art which is not considered to be of particular relevance *E* earlier document but published on or after the international filing date *L* document which may throw doubts on priority claim(s) or which is cited to establish the publication date of another citation or other special reason (as specified) *O* document referring to an oral disclosure, use, exhibition or other means *P* document published prior to the international filing date but later than the priority date claimed *T* later document published after the international filing date or priority date and not in conflict with the application but cited to understand the principle or theory underlying the invention *X* document of particular relevance; the claimed invention cannot be considered novel or cannot be considered to involve an inventive step when the document is taken alone *Y* document of particular relevance; the claimed invention cannot be considered to involve an inventive step when the document is combined with one or more other such documents, such combination being obvious to a person skilled in the art. *&* document member of the same patent family		
Date of the actual completion of the international search 17 March 2009		Date of mailing of the international search report 31/03/2009
Name and mailing address of the ISA/ European Patent Office, P.B. 5818 Patentlaan 2 NL - 2280 HV Rijswijk Tel. (+31-70) 340-2040, Fax: (+31-70) 340-3016		Authorized officer Swiderski, Piotr

INTERNATIONAL SEARCH REPORT

Information on patent family members

International application No

PCT/US2009/030410

Patent document cited in search report		Publication date		Patent family member(s)	Publication date
EP 1095740	A	02-05-2001	DE	60031822 T2	13-09-2007
US 2007039994	A1	22-02-2007	GB	2429424 A	28-02-2007
US 4552296	A	12-11-1985	NONE		