

H. SHAW & F. COOK.
Bale-Tie.

No. 200,672.

Patented Feb. 26, 1878.

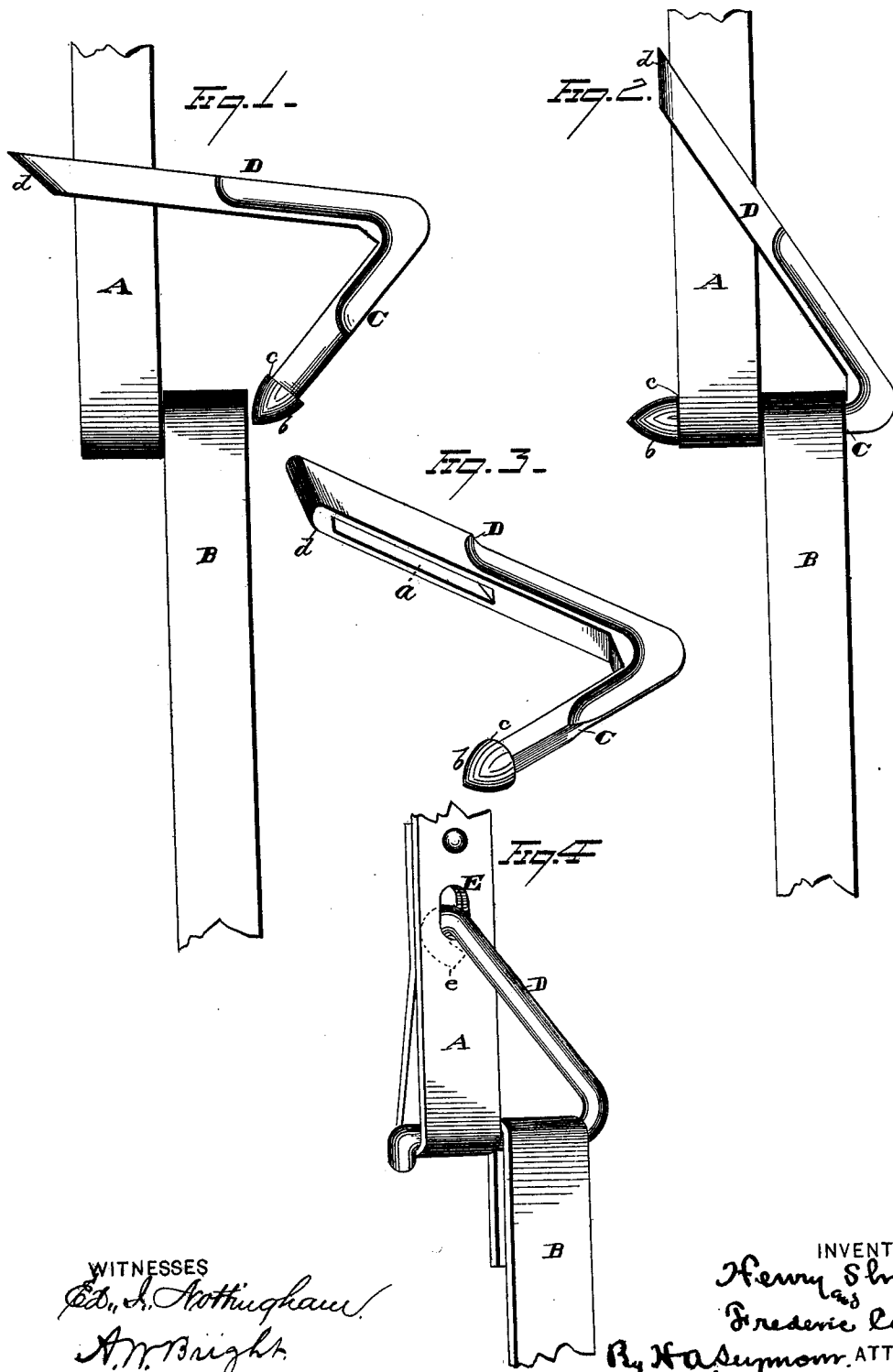

WITNESSES
Edw. S. Nottingham
A. W. Bright

INVENTORS
Henry Shaw
Frederic Cook
By *H. A. Symon* ATTORNEY

UNITED STATES PATENT OFFICE.

HENRY SHAW, OF WAVELAND, MISSISSIPPI, AND FREDERIC COOK, OF
NEW ORLEANS, LOUISIANA.

IMPROVEMENT IN BALE-TIES.

Specification forming part of Letters Patent No. **200,672**, dated February 26, 1878; application filed
January 31, 1878.

To all whom it may concern:

Be it known that we, HENRY SHAW, of Waveland, in the county of Hancock and State of Mississippi, and FREDERIC COOK, of New Orleans, in the parish of Orleans and State of Louisiana, have invented certain new and useful Improvements in Bale-Ties; and we do hereby declare the following to be a full, clear, and exact description of the invention, such as will enable others skilled in the art to which it pertains to make and use it, reference being had to the accompanying drawings, which form part of this specification.

Our invention relates to an improvement in bale-ties; the object being to provide a bale-tie of such construction that the opposite ends of the band may be secured to each other by means of a locking-bar, one end of which is connected with one end of the band, while the free or locking end of said bar passes through the loops formed on the opposite ends of the band or hoop, and firmly secures the same, so that said looped ends will lie side by side when on the bale.

Our invention consists, first, in a locking-bar attached to one end of a band or hoop in a manner whereby the free end of said bar may be moved away from the edge of the band to allow the end of the bar to be inserted through the loops on the opposite ends of the band when arranged side by side, whereby the strain on the band is exerted on opposite ends and sides of the locking-bar, and the latter retained against displacement by reason of its attachment to one end of the band.

Our invention further consists in a bale-tie consisting essentially of a locking-bar attached to one end of the band in such a manner that it may have both sliding and swinging movements imparted thereto, whereby the free end of said bar may be moved away from the edge of the band end to which it is attached, and allow both loops of the band to be secured side by side by means of the locking-bar passing through said loops. The sliding movement of the locking-bar allows its free end to seat firmly against the loop formed on the end of the band to which the bar is attached, and

thus receive the longitudinal strain exerted on the band.

Our invention further consists in a bale-tie consisting essentially of a locking-bar provided with a slotted angular brace, which receives one end of the band, the slot in said brace of sufficient length to allow of the lateral movement of the band therein, whereby the free end of the locking-bar may be swung away from the edge of the band, and allow said bar to be passed through both loops of the band when the same are arranged side by side.

Our invention further consists in the several details of construction, as will more fully appear from the following description and claims.

In the accompanying drawings, Figure 1 is a plan view of our invention, showing the parts of the tie preparatory to their being locked together. Fig. 2 represents the bale-tie after it has been properly secured. Fig. 3 is a view, in perspective, of the locking-bar. Fig. 4 is a modification.

A B represent the loops formed on the opposite ends of a band or hoop. C is a locking-bar, which is secured to the loop A by means of the slotted diagonal brace D, D, the latter being provided with a slot, *a*, of greater length than the width of the band, so that the latter may be freely moved either laterally or longitudinally in said slot. The outer end of locking-bar C is preferably provided with an enlarged head, *b*, for a purpose hereinafter described. The locking-bar C may be swung or moved away from the edges of the loop A, as represented in Fig. 1. The extremity of the opposite loop B is then brought in line with the end of loop A, when bar C is forced through both loops, as illustrated in Fig. 2, and operates to secure the same against displacement.

In order to prevent any lateral movement of the locking-bar C, when secured in place, it is furnished with the enlarged end or head *b*, the shoulder *c* of which engages with the edges of the band, constituting the loop A. Should the bar C become bent, owing to excessive strain on the same, the shoulder *c* will

wedge tightly between the edges of the loop, and prevent the lateral movement of said bar C.

When the loops A B are secured in place, as shown in Fig. 2, it will be observed that the strain is exerted on opposite ends and sides of the locking-bar C, and the latter is prevented from twisting or turning by means of the brace D, the outer end *d* of which rests against and is held in place by the edges of the loop on which it is placed.

In the form of bale-tie represented in Figs. 1 and 2 the ends of the band are not in anywise slotted or cut for the engagement or attachment of the locking-bar, and hence the strength of the band is in nowise impaired by the employment of our improved form of tie.

As the slotted brace is adapted to be freely moved on the looped end of the tie, it is easy of longitudinal adjustment. Also, when the locking-bar is secured in place, the sliding movement of the brace allows the bar to seat itself snugly within the looped end of the band to which the brace is attached. Again, the slotted brace serves to retain the extreme end of the band against lateral displacement.

A bale-tie constructed in accordance with our invention, as hereinbefore set forth, may be manufactured at a small initial cost, as the combined locking-bar and brace is formed of malleable or cast iron, and may be of comparatively light weight, and yet have the requisite strength for the purposes in view.

The looped ends of the band are readily and quickly secured by the locking-bar, and this is accomplished without the necessity of employing slack band in securing the tie.

When it is desired to release the tie, it is easily done, without injuring the band, by inserting a cotton-hook between the brace and edge of the loop and withdrawing the locking-bar from the looped ends of the band.

Fig. 4 represents a modification. The diagonal brace D has one of its ends inserted through an oblong slot, E, punched through the two thicknesses of the band, forming the loop A, and the extreme end *e* of the brace is bent back against the band, to prevent the disengagement of the brace. This latter form of tie is operated in the same manner as the tie heretofore described. It has a swinging and sliding movement, whereby it is adapted to secure the looped ends of the bands side by side.

It is evident that many slight changes in construction and arrangement of parts might be desired without departing from the spirit

of our invention; and hence we do not limit ourselves to the exact construction shown and described.

It is also evident that the locking-bar may be constructed with or without an enlarged head. A short hook may be formed on the outer end of the locking-bar, if desired.

Having fully described our invention, what we claim as new, and desire to secure by Letters Patent, is—

1. In a cotton-bale tie, a locking-bar, one end of which is connected to one end of the band in such a manner that the free end of said bar may be moved away from the edge of the band to allow the bar to be inserted through the loops on opposite ends of the band when said loops are arranged side by side, substantially as set forth.

2. In a cotton-bale tie, a locking-bar, one end of which is provided with a brace, which is connected with one end of the band in such a manner that the brace may have both sliding and rocking movements imparted thereto, whereby the free end of the locking-bar may be moved away from the edge of the band to allow the bar to be inserted through the loops on opposite ends of the band when said loops are arranged side by side, and the bar adapted to seat itself firmly in the looped end of the band, substantially as set forth.

3. In a cotton-bale tie, a locking-bar attached to one end of the band by a brace having a slot formed therein of greater length than the width of the band, whereby the locking-bar can be moved either laterally or longitudinally, and when the tie is secured the loop is secured within the slot against lateral displacement, substantially as set forth.

4. In a cotton-bale tie, a locking-bar attached to one end of the band by a diagonal slotted brace, whereby the twisting strain on the locking-bar is sustained by a brace located in the line of said strain, substantially as set forth.

5. In a cotton-bale tie, a locking-bar attached to one end of the band, and adapted to have both lateral and longitudinal movements imparted thereto, said locking-bar formed with an enlarged head or end, to prevent the lateral movement of said bar after it has been secured in place, substantially as set forth.

In testimony that we claim the foregoing we have hereunto set our hands.

HENRY SHAW.
FREDERIC COOK.

Witnesses:

A. W. BRIGHT,
C. P. COWL.