

Oct. 29, 1957

E. B. BEAM  
PORTABLE MIXER

2,811,338

Filed Sept. 20, 1954

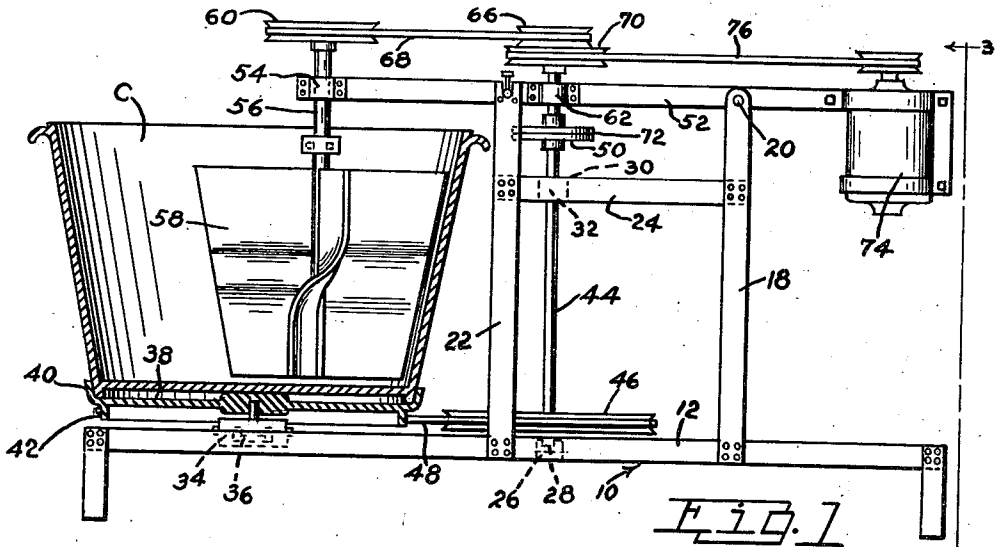

FIG. 1

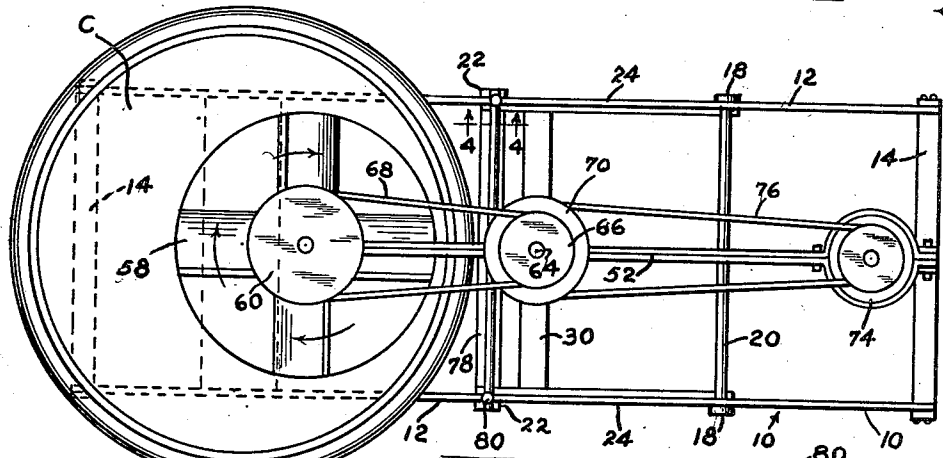

FIG. 2

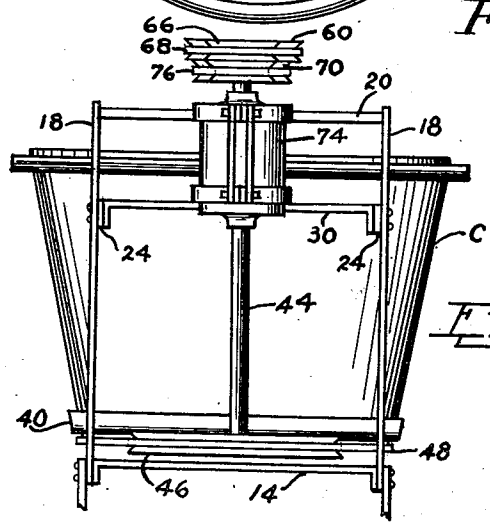

FIG. 3

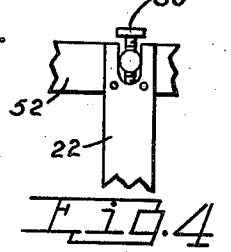

FIG. 4

INVENTOR  
EARL B. BEAM

BY

J. B. Dickman, Jr.  
ATTORNEY

1

2,811,338

**PORTABLE MIXER**

Earl B. Beam, Athens, Pa.

Application September 20, 1954, Serial No. 456,950

2 Claims. (Cl. 259—85)

This invention relates to a portable mixer and has for its primary object to intimately intermingle plasticized compositions such as plaster and the like.

Another object is to facilitate the mixing of plaster or the like in the immediate vicinity of application.

A further object is to mix the contents of one vessel while applying the contents of another vessel so that the vessels may be interchanged and the mixing process continued without interruption.

The above and other objects may be attained by employing this invention which embodies among its features a bed, a beam carried by the bed to move in a vertical arcuate path above the bed, a beater carried by the beam adjacent one thereof in a vertical arcuate path which intersects the bed, a jack shaft carried by the beam for rotation about an axis intermediate the ends thereof and having driving connection with the beater, a prime mover mounted on the beam adjacent the end thereof remote from the beater, said prime mover having driving connection with the jack shaft, a turn table carried by the bed for rotation beneath the beater, a drive shaft mounted on the bed for rotation beneath the jack shaft, said drive shaft having driving connection with the turn table, and separable means carried by the jack shaft and the drive shaft for establishing driving connection therebetween.

Other features include stops carried by the bed and intercepting the path of movement of the beam for engaging said beam and arresting movement of the beater toward the turn table.

In the drawings:

Figure 1 is a side view of a portable mixer embodying the features of this invention,

Figure 2 is a top plan view of Figure 1,

Figure 3 is an end view of Figure 1, on line 3—3, and

Figure 4 is an enlarged fragmentary detail view taken substantially on the line 4—4 of Figure 2.

Referring to the drawings in detail, a bed designated generally 10 comprises spaced parallel side bars 12 and end bars 14. Carried by and extending upwardly from the side bars 12 are spaced parallel columns 18 carrying adjacent their upper ends a pivot bar 20 which extends transversely between the columns as will be readily understood upon reference to the drawings. Standards 22 are carried by the side bars 12 and extend vertically upwardly therefrom in longitudinally spaced relation to the columns 18 and tie bars 24 are carried by and extend between the columns 18 and standards 22 in vertically spaced relation to the bed 10. Carried by the side bars 12 and extending transversely therebetween substantially midway between opposite ends of the bed 10 is a cross bar 26 carrying intermediate its ends a thrust bearing 28 and carried by the tie bars 24 and extending therebetween above the cross bar 26 is a bar 30 which carrying intermediate its ends is a journal bearing 32 which aligns axially with the thrust bearing 28.

Carried by the side bars 12 and extending transversely therebetween adjacent one end of the bed 10 is a transversely extending support bar 34 carrying midway be-

2

tween opposite ends a thrust bearing 36 upon which is mounted for rotation about a vertical axis a turn table 38. An upwardly extending annular flange 40 is carried by the turn table 38 to define a rim by which a container C is retained on the turn table. Carried by the turn table 38 and extending downwardly therefrom adjacent its periphery is an annular flange defining a pulley 42 by which the turn table 38 is rotated in the thrust bearing 36.

Mounted for rotation in the thrust bearing 28 and extending upwardly through the journal bearing 32 is a drive shaft 44 carrying adjacent its lower end a drive pulley 46 which has driving connection with the pulley 42 through the medium of an endless drive belt 48. A friction disk 50 is carried by the shaft 44 and extends across the upper end thereof for a purpose to be more fully hereinafter described.

Mounted on the pivot bar 20 to move about a horizontal axis in an arcuate path above the bed 10 is a support beam 52 carrying adjacent the end thereof above the turn table 38 a bearing 54 in which is mounted for rotation about an axis which extends perpendicularly to the pivot bar 20 a beater shaft 56. Carried by the beater shaft and extending downwardly therefrom above the turn table is a beater or mixing paddle 58 which is adapted to stir a plasticized mixture contained in the container C to cause the components thereof to intimately coningle. A pulley 60 is carried by the shaft 56 above the bearing 54 to cause the shaft to be driven when the pulley is rotated.

Mounted in a bearing 62 carried by the support bar 52 intermediate the ends thereof for rotation about an axis which lies parallel to the axis of the beater shaft 56 is a jack shaft 64 carrying adjacent its upper end a drive pulley 66 which has driving connection with the pulley 60 through the medium of an endless belt 68. A driven pulley 70 is mounted on the jack shaft 64 adjacent the pulley 66 for rotating said jack shaft and carried by the jack shaft and extending across the lower end thereof for rotation therewith is a friction disk 72 which when the parts are in operating position engages the friction disk 50 and causes the drive shaft 44 to rotate in unison with the jack shaft 64. A prime mover 74 is carried by the support beam 52 adjacent the end thereof remote from the beater 58 and has driving connection with the pulley 70 through the medium of an endless belt 76.

Carried by the beam 52 and extending transversely across the bed 10 above the standards is a stop bar 78 carrying adjacent opposite ends thumb screws 80 which as illustrated in Figure 4 engage the standards and limit downward movement of the beater 58.

In use the beam 52 is tilted about the axis of the pivot bar 20 to elevate the beater or stirrer 58. A tub or container C containing the plasticized material is then placed upon the turn table 38. The support beam 52 is then moved in its vertical arcuate path about the axis of the pivot bar 20 to lower the beater 58 into the plasticized material in the tub or container. Such movement will cause the friction disk 72 to engage the friction disk 50 and establish driving connection between the jack shaft 64 and the drive shaft 44. The prime mover 74 is then energized to rotate the turn table 38 and beater 58 in order to thoroughly mix the contents of the container C. As the beater 58 rotates in the direction of the arrows in Figure 2, downward pull on the beater and the beater shaft 56 will be exerted by the material being mixed and in order to preserve proper relationship between the bottom edge of the beater and the top surface of the bottom of the container C the thumb screws 80 are turned to preserve the desired clearance. It will thus be seen that the mixer may be adjusted for maximum efficiency and yet binding between the beater and the container may be avoided.

## I claim:

1. A portable mixer comprising a bed, a column carried by the bed and extending upwardly therefrom intermediate the ends thereof, a support beam mounted on said column intermediate its ends to move about a horizontal axis in a vertical arcuate path above the bed, a rotary beater mounted on the support beam adjacent one end thereof for rotation about an axis which lies perpendicular to the beam in its vertical plane and moves with the support beam in said arcuate path which lies in spaced concentric relation to said axis, a jack shaft mounted on the support beam intermediate the ends thereof to rotate about an axis which lies parallel to the axis of rotation of the beater and said jack shaft having driving connection with the beater, a prime mover carried by the support beam adjacent the end thereof remote from the beater to provide a counterbalance therefor and having driving connection with the jack shaft, a turn table carried by the bed for rotation about a vertical axis beneath the beater and excentric thereto, a drive shaft mounted on the bed to rotate about a vertical axis beneath the jack shaft and alined therewith, said drive shaft having driving connection with the turn table, separable means carried by the jack shaft and by the drive shaft for establishing driving connection between the jack shaft and the drive shaft, and stops carried by the bed and extending upwardly therefrom between the jack shaft and the beater for overcoming the tendency of the beater to move downwardly and scrape the bottom of a container resting on the turn table during the mixing of plasticized material in the container.

2. A portable mixer comprising a bed, a column carried by the bed and extending upwardly therefrom intermediate the ends thereof, a support beam mounted on said column intermediate its ends to move about a hori-

zontal axis in a vertical arcuate path above the bed, a rotary beater mounted on the support beam adjacent one end thereof for rotation about an axis which lies perpendicular to the beam in its vertical plane and moves with the support beam in an arcuate path which lies in spaced concentric relation to said axis, a jack shaft mounted on the support beam intermediate the ends thereof to rotate about an axis which lies parallel to the axis of rotation of the beater and said jack shaft having driving connection with the beater, a prime mover carried by the support beam adjacent the end thereof remote from the beater to provide a counterbalance therefor and having driving connection with the jack shaft, a turn table carried by the bed for rotation about a vertical axis beneath the beater and excentric thereto, a drive shaft mounted on the bed to rotate about a vertical axis beneath the jack shaft and alined therewith, said drive shaft having driving connection with the turn table, a friction disk carried by the jack shaft for rotation therewith, and a second friction disk carried by the drive shaft and intercepting the path of movement of the first mentioned friction disk for establishing driving connection between the jack shaft upon lowering of the beater and the drive shaft.

## References Cited in the file of this patent

## UNITED STATES PATENTS

661,793	Dolph	Nov. 13, 1900
1,984,619	Wright	Dec. 18, 1934
2,425,942	Kooman	Aug. 19, 1947
2,438,465	Strauss et al.	Mar. 23, 1948
2,651,582	Courtney	Sept. 8, 1953

## FOREIGN PATENTS

4,853	Great Britain	Mar. 8, 1905
-------	---------------	--------------