

No. 853,774.

PATENTED MAY 14, 1907.

G. W. DAVIES.  
HYDRAULIC MOTOR.  
APPLICATION FILED SEPT. 20, 1906.

2 SHEETS—SHEET 1.

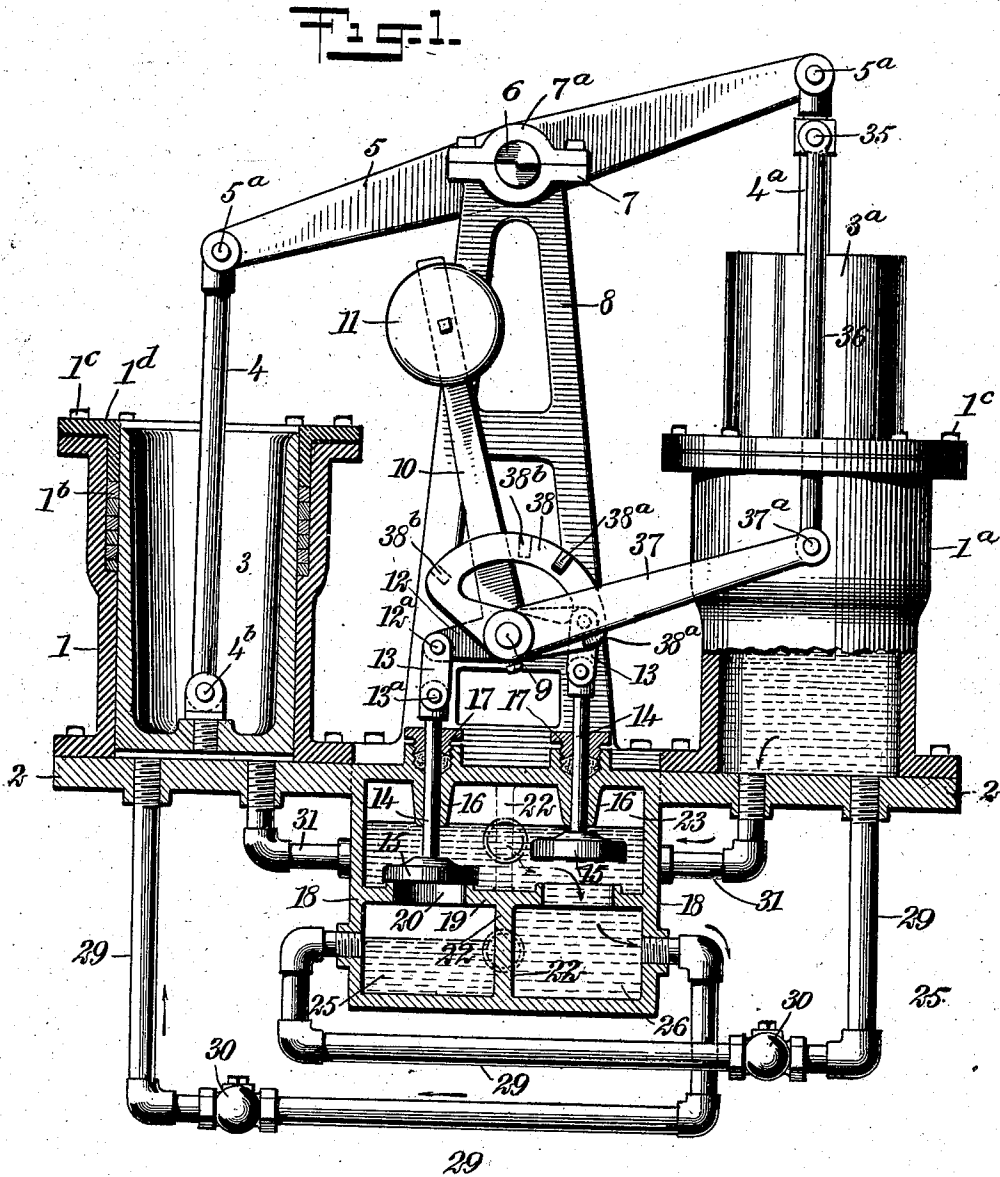

WITNESSES  
*Geo. W. Taylor*  
*G. W. Davies*

INVENTOR  
*George W. Davies*  
BY *Mumford*  
ATTORNEYS

No. 853,774.

PATENTED MAY 14, 1907.

G. W. DAVIES.  
HYDRAULIC MOTOR.  
APPLICATION FILED SEPT. 20, 1906.

2 SHEETS—SHEET 2.

Fig. 2.

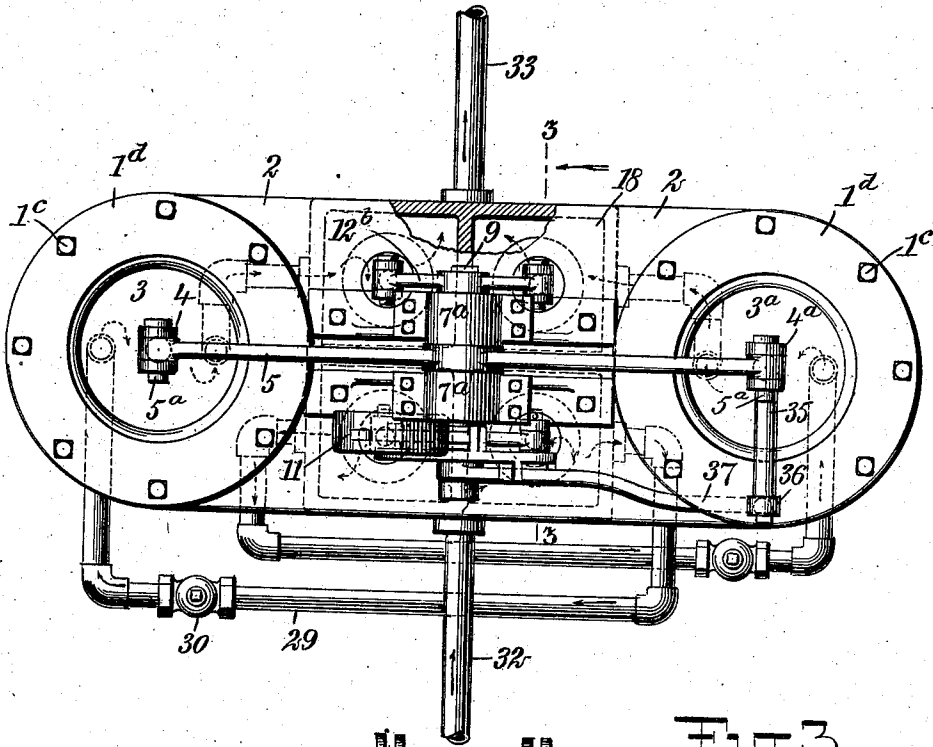
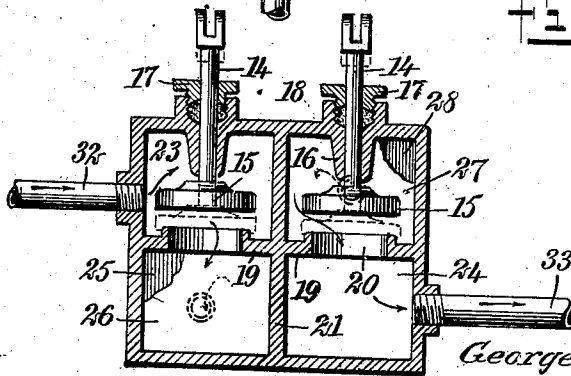

Fig. 3.



WITNESSES

*Geo. W. Taylor*  
*Robt. Hardie*

INVENTOR

*George W. Davies*

BY *Munn & Co*

ATTORNEYS

# UNITED STATES PATENT OFFICE.

GEORGE W. DAVIES, OF NEW YORK, N. Y., ASSIGNOR OF ONE-HALF TO  
FRANK ASSENBECK, OF NEW YORK, N. Y.

## HYDRAULIC MOTOR.

No. 853,774.

Specification of Letters Patent.

Patented May 14, 1907.

Application filed September 20, 1906. Serial No. 335,404.

*To all whom it may concern:*

Be it known that I, GEORGE W. DAVIES, a citizen of the United States, and a resident of the city of New York, borough of the Bronx, in the county and State of New York, have invented a new and Improved Hydraulic Motor, of which the following is a full, clear, and exact description.

The object of this invention is to provide an hydraulic motor simple in construction, effective in operation and durable in use.

Figure 1 is a side elevation, partly in section, of a motor embodying my invention; Fig. 2 is a plan view of the same, partly broken away; and Fig. 3 is a transverse section taken on the line 3—3 of Fig. 2.

As illustrated in the drawings, twin cylinders 1 and 1<sup>a</sup> are mounted upon a bed plate 2 and provided with open-ended cylindrical pistons 3 and 3<sup>a</sup> pivotally attached to piston rods 4 and 4<sup>a</sup> by means of pivot pins 4<sup>b</sup>, the piston rods being attached to a rocking beam 5 by means of pivots 5<sup>a</sup>. The beam 5 is mounted upon a shaft 6 which is journaled in bearings 7, formed on the upper ends of standards 8, which standards are also mounted upon the bed plate 2. The upper ends of the cylinders are provided with angular glands 1<sup>d</sup> adapted to bear at their under edge against packing rings 1<sup>b</sup> arranged around the cylindrical surface of the pistons. The glands 1<sup>d</sup> are adapted to be adjustably secured to the ends of the cylinders by means of stud bolts 1<sup>c</sup>. A shaft 9 is journaled in suitable bearings on the standards 8, and supports a lever 37 which is freely journaled on the end of said shaft at one end and is pivoted at its opposite end to a connecting rod 36 by means of a pivot pin 37<sup>a</sup>. The connecting rod 36 is pivotally connected to a shaft 35 which is attached to the piston rod 4<sup>a</sup>, as shown in Fig. 2. A segment 38 is also freely mounted upon the shaft 9 and provided with lugs 38<sup>a</sup> adapted to bear against the lever 37, and lugs 38<sup>b</sup> adapted to bear against a lever 10, which is rigidly secured to the shaft 9, and provided on its upper end with a weight 11 and on its lower end with oppositely extending arms 12 having links 13 pivotally secured at one end to said arms by means of pivot pins 12<sup>a</sup>, and at their opposite ends said links are pivoted by means of pivot pins 13<sup>a</sup> to valve stems 14 having valves 15

secured thereto. Rock arms 12<sup>b</sup> are also fixedly secured to the opposite end of the shaft 9, and pivotally connected to valve stems 14 having valves 15 secured thereto as shown in Figs. 2 and 3. The valve stems 14 extend through packing boxes 16 formed on the top of a water tank 18 provided with packing glands 17. The water tank 18 is divided into upper and lower compartments, by means of a horizontal partition 19 having valve ports 20 formed therein, adapted to be closed by the valves 15. A vertical partition 21 extends from the top to the bottom of the water tank 18 lengthwise thereof, thereby, in connection with the horizontal partition 19, dividing the water tank into four equal compartments. The lower compartment on one side of the tank and the upper compartment on the opposite side thereof are divided into sub-compartments by means of transverse partitions 22, thereby forming an inlet chamber 23 on the upper portion of the front of the water tank, a lower discharge chamber 24 on the back portion of said tank feed chambers 25 and 26 on the front of the tank, and outlet chambers 27 and 28 on the back portion of the tank. The feed chambers 25 and 26 are each connected with the cylinders 1 and 1<sup>a</sup> by means of pipe connections 29 having check valves 30 connected therewith; and the outlet chambers 27 and 28 are also connected with the cylinders 1 and 1<sup>a</sup> by means of pipes 31.

When the motor is in operation and the inlet chamber 23 is connected by means of the inlet pipe 32 with a water supply under pressure, the chamber becomes filled with water, which passes through the valve ports 20 into one of the feed chambers 25 or 26 and from thence through the pipes 29 into the cylinders 1 and 1<sup>a</sup>. When the valves 15 are in the position shown in Fig. 1, the piston 3<sup>a</sup> of the cylinder 1<sup>a</sup> is raised, and its cylinder filled with water. As the water under pressure enters the opposite cylinder 1, the piston 3 is raised and the water is forced out of the opposite cylinder 1<sup>a</sup> by the opposite piston descending, thereby forcing the water into the outlet chamber 27. The valves 15 of the rear outlet chambers 27 and 28, being connected with the rock arms 12<sup>a</sup> rigidly secured to the shaft 9, operate in harmony with the corresponding valves 15 connected with the

arms 12 secured to said shaft. By means of such construction, the water from the outlet chambers 27 and 28 passes outward into the discharge chamber 24, and from the chamber 24 through the discharge pipe 33 when the respective valve of its chamber is raised from the port 20. While one of the pistons, 3<sup>a</sup>, is on its upward stroke, the valve 15, which controls the port leading to the feed chamber 26 and the supply pipe 29 connected with said cylinder, is open, and the corresponding valve, which controls the port communicating with the supply pipe leading to the opposite cylinder is closed. After the piston has reached the limit of its upward stroke, as shown in Fig. 1, the rod 36 connected with the piston rod 4<sup>a</sup>, raises the lever 37, which is mounted upon the shaft 9, and brings said lever in contact with one of the lugs 38<sup>a</sup> formed on the segment 38, which is also freely mounted upon the shaft 9, and preferably arranged on said shaft between the lever 37 and the weighted lever 10. During the upward movement of the piston 3<sup>a</sup>, therefore, the outer end of the lever 37 moves in harmony with the piston, without affecting either of the valves 15. As the piston reaches the upper portion of the stroke, the lever 37 comes in contact with one of the lugs 38<sup>a</sup> of the segment 38, and rocks said segment on the shaft 9 until one of the lugs 38<sup>b</sup> on the opposite side of the segment comes in contact with the weighted lever 10 and carries said lever over its center of gravity. When the lever is carried beyond its center of gravity, the weight 11 on the upper end of said lever causes one of the valves 15 to drop quickly onto its seat, thereby covering the adjacent port 20, opening the opposite port on the same side of the water tank, as shown in Fig. 1, and permitting the water in the receiving chamber 23 to pass through said port and into the lower portion of the opposite cylinder 1, which thereby causes the piston 3<sup>a</sup> to descend and force the water out of said cylinder into the outlet chamber 27 and from thence into the discharge chamber 24, and out of said chamber through the discharge pipe 33.

Having thus described my invention, what I claim as new and desire to secure by Letters Patent is:

1. The combination with twin cylinders provided on one end with inlet and outlet ports, of a water tank provided with a receiving chamber, and feed chambers communicating therewith by means of valve ports, a discharge chamber provided with valve ports having outlet chambers connected therewith, pipe connections between the feed chambers and the inlet ports of the cylinders, pipe connection between the outlet chambers and the outlet ports of the cylinders, rock arms mounted upon a shaft and connected with a weighted lever, valves pivoted to said arms and adapted to open and close

the ports of the feed and outlet chambers, and means for operating said valves and lever, substantially as shown and described.

2. The combination with twin cylinders provided on one end with inlet and outlet ports, of a water tank provided with a receiving chamber, and feed chambers provided with valve ports connected therewith, a discharge chamber having outlet chambers connected therewith by means of valve ports, pipe connections between the feed chambers and the inlet ports of the cylinders, pipe connections between the outlet chambers and the outlet ports of the cylinders, rock arms mounted upon a shaft having a weighted lever connected therewith, valves pivoted to said rock arms and adapted to open and close said ports, pistons movable lengthwise of said cylinders, a rocking beam connected with said pistons, and mechanism connected with said pistons and shaft, adapted to operate said valves, substantially as shown and described.

3. The combination with two cylinders provided on one end with inlet and outlet ports, of a receiving chamber and feed chambers connected therewith, a discharge chamber having outlet chambers connected therewith, pipe connections between the feed chambers and the inlet ports of the cylinders, pipe connections between the outlet chambers and the outlet ports of the cylinders, a rock shaft, valves connected with said rock shaft and adapted to open and close the valve ports between the receiving chamber and feed chambers, and a discharge chamber and outlet chambers respectively, pistons movable lengthwise of said cylinders, a rocking beam connected with said pistons, and mechanism connected with said rocking shaft adapted to operate said valve at the end of the stroke of said pistons, substantially as shown and described.

4. The combination with two cylinders provided on one end with inlet and outlet ports, of a receiving chamber and feed chambers connected therewith by means of valve ports, a discharge chamber having outlet chambers connected therewith by means of valve ports, pipe connections between the feed chambers and the inlet ports of the cylinders, pipe connections between the outlet chambers and outlet ports of the cylinders, a rock shaft having a weighted lever mounted thereon, valves connected with said rock shaft adapted to control said valve ports, pistons movable lengthwise of said cylinders and connected together, and an arm freely mounted on said rock shaft connected with one of said pistons and adapted to operate said valves at the ends of the piston strokes, substantially as shown and described.

5. The combination with a rocking beam, of pistons connected to said beam, cylinders adapted to receive said pistons and provided

with inlet and outlet ports, a receptacle having independent feed chambers communicating with said inlet ports and provided with valve ports, and independent outlet chambers communicating with said outlet ports and provided with valve ports, valves controlling said valve ports, and mechanism connected with said pistons adapted to operate said valves at the end of each piston stroke, and to permit said valves to remain at rest between said interval, substantially as shown and described.

6. The combination with a rocking beam, of pistons pivotally mounted thereon, cylinders adapted to receive said pistons and pro-

vided with independent inlet and outlet ports, a rock shaft, valves connected with said rock shaft, a weighted lever fixedly secured to said shaft, a trip lever loosely mounted on said shaft and connected with said pistons, and means freely mounted on said shaft adapted to connect said levers, substantially as shown and described.

In testimony whereof I have signed my name to this specification in the presence of two subscribing witnesses.

GEO. W. DAVIES.

Witnesses:

JNO. M. RITTER,  
ROBERT W. HARDIE.