

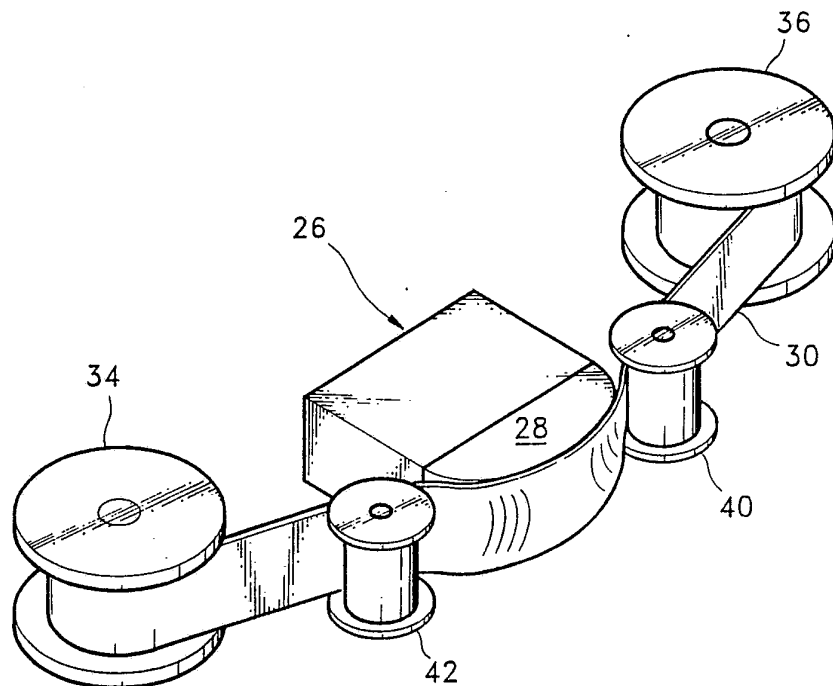

## INTERNATIONAL APPLICATION PUBLISHED UNDER THE PATENT COOPERATION TREATY (PCT)

<p>(51) International Patent Classification <sup>5</sup> : <b>G11B 7/24, 7/00, 15/60</b></p>	<p><b>A1</b></p>	<p>(11) International Publication Number: <b>WO 93/23849</b> (43) International Publication Date: 25 November 1993 (25.11.93)</p>
<p>(21) International Application Number: PCT/KR92/00057 (22) International Filing Date: 3 November 1992 (03.11.92) (30) Priority data: 883,484 15 May 1992 (15.05.92) US (71) Applicant: SAMSUNG ELECTRONICS CO., LTD. [KR/KR]; 416, Maetan-dong, Kwonsun-ku, Suwon, Kyungki-do 441-742 (KR). (72) Inventors: SCHAEFER, Louis, F. ; 3845 Mumford Place, Palo Alto, CA 94306 (US). SHRADER, Eric, J. ; P.O. Box 710, La Honda, CA 94020 (US). (74) Agent: LEE, Young, Pil; 2nd and 3rd Floors, Cheonghwa Bldg., 1571-18, Seocho-dong, Seocho-ku, Seoul 137-073 (KR).</p>		<p>(81) Designated States: JP, KR, European patent (AT, BE, CH, DE, DK, ES, FR, GB, GR, IE, IT, LU, MC, NL, SE).  <b>Published</b> <i>With international search report.</i></p>

(54) Title: DEVICE FOR IMPARTING CURVATURE ACROSS THE WIDTH OF AN OPTICAL RECORDING MEDIUM



## (57) Abstract

A device for imparting curvature across the width of an optical recording medium (30) includes a form (26) that is provided with a guide portion (28). The guide portion (28) has a front guiding surface (32) against which the optical recording medium (30) is guided. The guide portion (28) of the form (26) is convex while the front guiding surface (32) of the guide portion (28) is concave. The concave shape of the front guiding surface (32) causes the optical recording medium (30) to curve concavely across its width as the optical recording medium (30) is guided along the front guiding surface (32).

*FOR THE PURPOSES OF INFORMATION ONLY*

Codes used to identify States party to the PCT on the front pages of pamphlets publishing international applications under the PCT.

AT	Austria	FR	France	MR	Mauritania
AU	Australia	GA	Gabon	MW	Malawi
BB	Barbados	GB	United Kingdom	NL	Netherlands
BE	Belgium	GN	Guinea	NO	Norway
BF	Burkina Faso	GR	Greece	NZ	New Zealand
BG	Bulgaria	HU	Hungary	PL	Poland
BJ	Benin	IE	Ireland	PT	Portugal
BR	Brazil	IT	Italy	RO	Romania
CA	Canada	JP	Japan	RU	Russian Federation
CF	Central African Republic	KP	Democratic People's Republic of Korea	SD	Sudan
CG	Congo	KR	Republic of Korea	SE	Sweden
CH	Switzerland	KZ	Kazakhstan	SK	Slovak Republic
CI	Côte d'Ivoire	LJ	Liechtenstein	SN	Senegal
CM	Cameroon	LK	Sri Lanka	SU	Soviet Union
CS	Czechoslovakia	LU	Luxembourg	TD	Chad
CZ	Czech Republic	MC	Monaco	TG	Togo
DE	Germany	MG	Madagascar	UA	Ukraine
DK	Denmark	ML	Mali	US	United States of America
ES	Spain	MN	Mongolia	VN	Viet Nam
FI	Finland				

DEVICE FOR IMPARTING CURVATURE ACROSS THE WIDTH  
OF AN OPTICAL RECORDING MEDIUM

Technical Field

5           The present invention generally relates to a device for use in an optical recording system and, more particularly, to a device for use in, for example, an optical video tape record and playback system.

Background Art

10           It is known that storage of data on a recording tape can be accomplished by using magnetic storage techniques in which the recording tape is moved into contact with a read/write head for purposes of writing information on the tape and reading the stored information. By way of example, such a system is shown in Figure 1. As shown in that drawing, a tape 10 is brought into engagement with a read/write head 12 by way of  
15 several movable tape engaging guides 14. The read/write head 12 writes information on the tape 10 and also reads information that is stored on the tape 10.

          Recently, attention has turned to optical recording technology as an alternative to magnetic storage techniques for storing data on a recording tape. In optical recording technology, a beam of light (e.g., a laser beam) is directed at and scans across the width  
20 of a moving data storage medium, such as a flexible optical tape, to produce unique domains on the tape that represent binary data bits. This technology is described in more detail in, for example, United States Patent Nos. 4,719,615 and 4,912,696, the disclosure of which is incorporated herein by reference.

          Generally speaking, optical recording technology involves the use of a source of  
25 light which directs a light beam at a mirror or other reflective surface, whereupon the

light beam is reflected and directed at the optical tape. Typically, the mirror is connected to a suitable operating device (e.g., a motor and control system) that causes the mirror to rotate slightly back and forth. The rotation of the mirror causes the light beam to scan back and forth across the width of the tape as the light beam is reflected off the mirror.

5 In this way, information can be stored on the tape in the form of unique domains, and information already stored on the tape can be read.

As a result of the foregoing arrangement and operation, the light beam reflected from the reflecting device moves in an arcuate path that defines an arc of a circle. If the portion of the optical tape being scanned possesses a relative flat configuration, the focal  
10 point of the light beam must be continually adjusted as the beam scans across the width of the tape. This is so because the focal point of the light beam when the beam is directed at, for example, the middle of the optical tape is different from the focal point of the light beam when the beam is directed at, for example, the edge of the tape. In order to ensure proper focusing of the beam at all times, it would be necessary, therefor, to employ  
15 relatively complicated focusing optics.

#### Disclosure of The Invention

Generally speaking, the present invention provides an optical video tape record and playback system that would eliminate the need for complex focusing optics and  
20 thereby simplify the overall design of the system. More particularly, the present invention provides a device that imparts curvature across the width of an optical recording medium. The device includes a guide portion that has a front guiding surface along which the optical recording medium is guided. The front guiding surface is concave to cause the optical recording medium to curve across its width as the optical recording medium is  
25 guided along the guide portion of the form.

In accordance with a preferred embodiment of the present invention, the guide portion of the form can be convex to help ensure that the optical recording medium is forced against the front guiding surface. Also, the device can include an extension that is connected to the form and that extends away from the front guiding surface to help  
5 guide the optical recording medium across the front guiding surface.

In accordance with another aspect of the present invention, a system for writing and reading data on an optical recording medium includes a light source for providing a light beam, an arrangement for focusing and directing the beam of light from the light source onto the optical recording medium to produce spots on the optical tape  
10 representing bits of data and to read stored data on the optical tape, and a form around which the optical tape is to be guided. The form includes a guide portion having a front guiding surface against which the optical recording medium is to be guided. The guiding surface is concave that the optical tape is curved across its width as the optical tape is guided along the guide portion of the form.

15 In accordance with a preferred embodiment of the system, the form can be convex to help ensure that the optical tape is pressed against the front guiding surface as the optical tape is guided past the guide portion. The system can also include two spaced apart guide rollers, each of which is positioned at one end of the guide portion of the form.

20 In accordance with a still further aspect of the present invention, a method of storing data on an optical recording medium and reading stored data on the optical recording medium includes the steps of withdrawing an optical tape from a feed reel, imparting a curvature across the width of the optical tape by guiding the optical tape along a concave front guiding surface of a guide portion of a form, scanning a light beam  
25 back and forth across the width of the optical recording medium, and winding the optical

tape onto a take-up reel. In the preferred embodiment, the optical recording medium is guided across a convex guide portion in order to help ensure that the optical tape is pressed against the front guiding surface as the optical tape is guided past the guide portion.

5

#### Brief Description of The Drawings

The present invention can be further understood with reference to the following description in conjunction with the appended drawings, wherein like elements have been provided with the same reference numerals. In the drawings:

10 Figure 1 is a front view of a known read/write head used in systems which store data on a recording tape by way of magnetic storage techniques;

Figure 2 is a perspective view of the form according to the present invention, illustrated in conjunction with a portion of an optical video tape record and playback system; and

15 Figure 3 is a schematic illustration of a portion of an optical video tape record and playback system incorporating the form according to the present invention.

#### Best Mode for Carrying Out The Invention

20 Figures 2 and 3, generally speaking, show a portion of a system for optically recording data on an optical recording medium and for reading stored data on the optical recording medium. The system can, for instance, form a portion of an optical video tape record and playback unit. Preferably, the optical recording medium is a flexible optical tape. While the system includes additional features, those additional features have not been described or illustrated herein.

25 As shown in Figure 3, the system includes a light source 20, a focusing

mechanism 22, a reflecting device 24 and a guide member 26, all of which are preferably mounted within a housing (not shown) of the optical video tape record and playback unit. The light source is adapted to produce a light beam 21, preferably a laser light beam. The light beam 21 produced by the light source 20 is directed at the focusing mechanism 5 22. The focusing mechanism 22 can be any suitable and known mechanism for use in focusing the light beam from the light source 20.

The focused light beam emerging from the focusing mechanism 22 is then directed at the reflecting device 24. The reflecting device 24 can be a mirror or any other suitable device capable of reflecting light. The reflecting device 24 is mounted for rotation and 10 is connected to a suitable control device 25. The control device 25 controls operation of a motor or other suitable apparatus (not shown) for rotating the reflecting device 24 in the manner represented by the arrow A. The rotation of the reflecting device 24 causes the beam of light 21 to move up and down as shown in Figure 3. In that way, the light beam 21 can scan back and forth across the width of the optical tape as the tape is 15 moving in a direction parallel to its length. Thus, the amount of rotation of the reflecting device should be sufficient to permit the light beam 21 to scan the entire width of the optical tape.

The light beam 21 that is reflected from the reflecting device 24 is directed at the guide member 26. As is shown most clearly in Figure 2, the guide member or form 26 20 includes a guide portion 28. This guide portion 28 faces in the general direction of the reflecting device 24. For reasons that will become apparent from the description that follows, the guide portion 28 is convex as seen from above the form 26. Specifically, the guide portion 28 of the form 26 is convex toward the reflecting device 24.

As most clearly illustrated in Figure 3, the guide portion 28 is provided with a 25 front guiding surface 32 that faces in the direction of the reflecting device 24. The front

guiding surface 32 of the guide portion 28 is concavely curved from the top surface 33 of the form 26 to the bottom surface 35 (i.e., as seen from the side of the form 26). More particularly, the front guiding surface 32 is concavely curved away from the reflecting device 24.

5 As shown in Figure 2, the system can be provided with two reels 34, 36 which, depending upon the direction of movement of the flexible optical tape 30, define a take-up reel and a feed reel. The tape 30 is unwound from one of the reels (e.g., reel 34), is guided along the front guiding surface 32 of the guide portion 28 of the form 26, and is then wound on the other reel (e.g., reel 36).

10 As the optical tape 30 is guided along the front guiding surface 32, the concave curvature of the front guiding surface 32 imparts a similar concave curvature across the width of the optical tape 30. Preferably, the radius of curvature of the front guiding surface 32 is selected such that it is equal to or substantially equal to the distance between the reflecting device and the front guiding surface 32 (as measured along the light beam  
15 30). As a result, the light beam 30 reflected from the reflecting device 24 traces an arc of a circle that substantially corresponds to the circular arc defined by the concave front guiding surface 32. Stated differently, the distance between the concave front guiding surface 32 and the reflecting surface of the reflecting device 24 (as measured along the light beam that is reflected from the reflecting device 24) is the same or substantially the  
20 same, regardless of whether the light beam is directed at the middle of the optical tape 30, the edges of the optical tape 30, or some other point on the optical tape 30. Due to the foregoing correlation, it is not necessary to provide complex focusing optics because the focal point of the light beam 21 relative to the optical tape 30 remains substantially constant as the light beam 21 scans the width of the optical tape 30.

25 To ensure that the advantages associated with providing a concave guiding surface

32 are fully realized, the optical tape 30 should preferably be in contact with or substantially in contact with the front guiding surface 32 of the guide portion 28 as the optical tape 30 is guided past the guide portion 28 of the form 26. So long as sufficient tension is applied to the optical tape 30, that objective can be achieved.

5        Although the optical tape 30 is in tension as it is wound onto one of the reels 34, 36, that tension may not be sufficient to force the optical tape 30 against the front guiding surface 32 of the guide portion 28. To further facilitate the tensioning, the guide portion 28 of the form 26 is convex. In addition, the guide portion 28 of the form 26 is positioned slightly forwardly of the reels 34, 36 (i.e., slightly forwardly in the direction  
10 of the reflecting device 24). That is, the guide portion 28 of the form 26 is positioned slightly forwardly of an imaginary line extending between the rotational axes of the reels 34, 36.

The combination of the aforementioned two features helps ensure that the optical tape 30 is pulled sufficiently to force it against the front guiding surface 32 of the guide  
15 portion 28. The extent to which the guide portion 28 of the form 26 is positioned forwardly of the reels 34, 36 and the amount of curvature of the convex guide portion 28 can be selected to ensure that sufficient tension is applied to the optical tape.

To help guide the optical tape 30 and further ensure that the tape is sufficiently in tension, guide rollers 40, 42 can be provided. The guide rollers 40, 42 are preferably  
20 positioned at opposite ends of the guide portion 28 of the form 26.

Additionally, as best shown in Figure 3, a guide element 46 is provided to help guide the tape and prevent it from sliding upwardly along the front guiding surface 32. The guide element 46 can be in the form of an extension member that is connected to the guiding portion 28 of the form 26 and that extends away from the front guiding surface  
25 32. Of course, other suitable arrangements could be employed for serving substantially

the same purpose as the guide element 46.

In operation, the optical tape 30 is unwound from one of the reels (e.g., reel 34), is guided behind the guide roller 40, is guided along the guiding portion 26, is passed behind the other guide roller 42 and is wound on the other reel 34. The optical tape 30 is in a flat configuration as it moves from the take-off reel 34 and around the guide roller 40. The optical tape 30 begins to curve across its width as it is forced against the front guiding surface 32. As it leaves the form 26, the optical tape 30 once again returns to its flat configuration as it moves behind the guide roller 42. As a result of the foregoing mode of operation, the optical tape 30 is forced against the front guiding surface 32 so that the optical tape 30 is concave across its width.

While the optical tape 30 tape is moving past the guiding portion 28 of the form 26, the light beam 21 (e.g., laser beam) that is reflected off the reflecting device 24 scans back and forth across the width of the optical tape 30 (through suitable rotation of the reflecting device) to either write information on the optical tape 30 or to read information that has already been stored on the optical tape 30. Because the curvature of the front guiding surface 32 matches or substantially matches the arc traced by the scanning light beam 21, the focusing optics, as well as the entire focusing system, can be greatly simplified.

The foregoing has described the principles, preferred embodiments and modes of operation of the present invention. However, the invention should not be construed as limited to the particular embodiments discussed. Instead, the above-described embodiments should be regarded as illustrative rather than restrictive, and it should be appreciated that variations and changes may be made by workers skilled in the art, and equivalents employed, without departing from the scope of the present invention as defined by the following claims.

Industrial Applicability

The present invention can be adapted in an optical recording system, that is, an optical video tape record and playback system, to thereby provide a device that imparts curvature across the width of an optical recording medium.

What is Claimed is:

1. A device for imparting curvature across the width of an optical recording medium, comprising:

a form having a guide portion along which the optical recording medium is to be  
5 guided, the guide portion being curved convexly and having a front guiding surface  
against which the optical recording medium is to be guided, the front guiding surface  
having a concave shape to cause the optical recording medium to curve concavely across  
its width as the optical recording medium is guided along the guide portion surface.

2. The device according to claim 1, including means for guiding the optical  
10 reading medium along the guide portion.

3. The device according to claim 1, wherein the means for guiding includes an  
extension connected to the form and extending away from the front guiding surface.

4. A device for guiding an optical recording medium and for causing the optical  
recording medium to curve across its width, comprising: a form having a guide portion  
15 along which the optical recording medium is to be guided, the guide portion having a  
front guiding surface against which the optical recording medium is guided, the front  
guiding surface having a concave curvature to impart a concave curvature across the  
width of the optical recording medium as the optical recording medium moves along the  
guide portion, and including means for ensuring that as the optical recording medium  
20 moves along the guide portion the optical recording medium is forced against the front  
guiding surface to thereby cause the optical recording medium to curve across its width.

5. The device according to claim 4, wherein the means for ensuring that the  
optical recording medium is forced against the front guiding surface includes the guide  
portion being curved convexly.

25 6. The device according to claim 4, including an extension connected to and

extending away from the form at an upper portion of the form.

7. The device according to claim 4, including two spaced apart guide rollers, one of the guide rollers being positioned at each end of the form.

8. A system for writing and reading data on an optical recording medium,  
5 comprising:

a light source for providing a beam of light that can be used to store information on the optical recording medium and to read store information;

means for focusing and directing the beam of light from the light source onto an optical recording medium; and

10 a form around which the optical recording medium tape is guided and towards which the light beam from the light source is directed, the form having a guide portion, the guide portion having a front guiding surface against which the optical recording medium is guided, the front guiding surface being concave so that the optical recording medium is concave across its width when the optical recording medium is guided along  
15 the guide portion.

9. The system according to claim 8, including means for helping to ensure that the optical recording medium is pressed against the front guiding surface when the optical recording medium is guided past the guide portion.

10. The system according to claim 9, wherein the means for helping to ensure that  
20 the optical recording medium is pressed against the front guiding surface includes the guide portion being convex.

11. The system according to claim 8, including an extension connected to and extending away from the form at an upper end of the guide portion.

12. The system according to claim 11, including two spaced apart guide rollers,  
25 each of which is positioned at one end of the guide portion of the form.

13. The system according to claim 8, wherein the means for focusing and directing the beam of light from the light source onto an optical recording medium includes a rotatably mounted reflecting device having a reflecting surface so that a light beam which strikes a point on the reflecting surface when the reflecting device is in a first position strikes a point on the optical recording medium.

14. The system according to claim 8, wherein the radius of curvature of the front guiding surface is substantially equal to the distance between the point on the optical recording medium and the point on the reflecting surface when the reflecting device is in the first position.

15. The system according to claim 8, including two reels onto which the optical recording medium is wound and from which the optical recording medium is unwound, the means for focusing and directing the beam of light from the light source onto an optical recording medium including a reflecting device, at least a part of the guide portion of the form being positioned beyond, in the direction of the reflecting device, an imaginary line extending between axes of the reels.

16. A method for storing data on an optical recording medium and for reading stored data on the optical recording medium, comprising the steps of:

unwinding an optical recording medium from a feed reel;

imparting curvature across the width of the optical recording medium by guiding the optical recording medium along a concavely-shaped front guiding surface of a guide portion of a form;

scanning a light beam back and forth across the width of the optical recording medium; and

winding the optical recording medium onto a take-up reel.

17. The method according to claim 16, wherein the optical recording medium is

guided across a convexly-shaped guide portion in order to help ensure that the optical recording medium tape is pressed against the front guiding surface.

18. The method according to claim 16, including the step of passing the optical recording medium behind a guide roller before guiding the optical recording medium 5 along the concavely-shaped front guiding surface of the guide portion of the form, and passing the optical recording medium over a guide roller after the optical recording medium has been guided along the concavely-shaped front guiding surface of the guide portion of the form.

FIG. 1

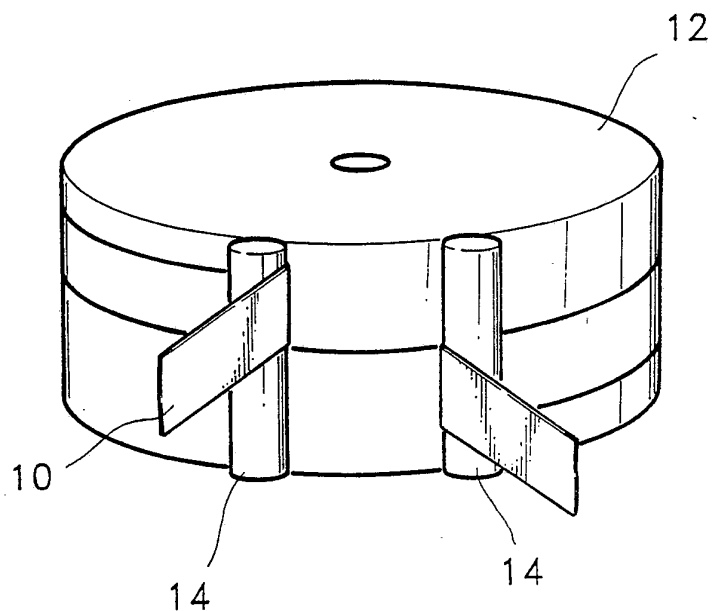

FIG. 3

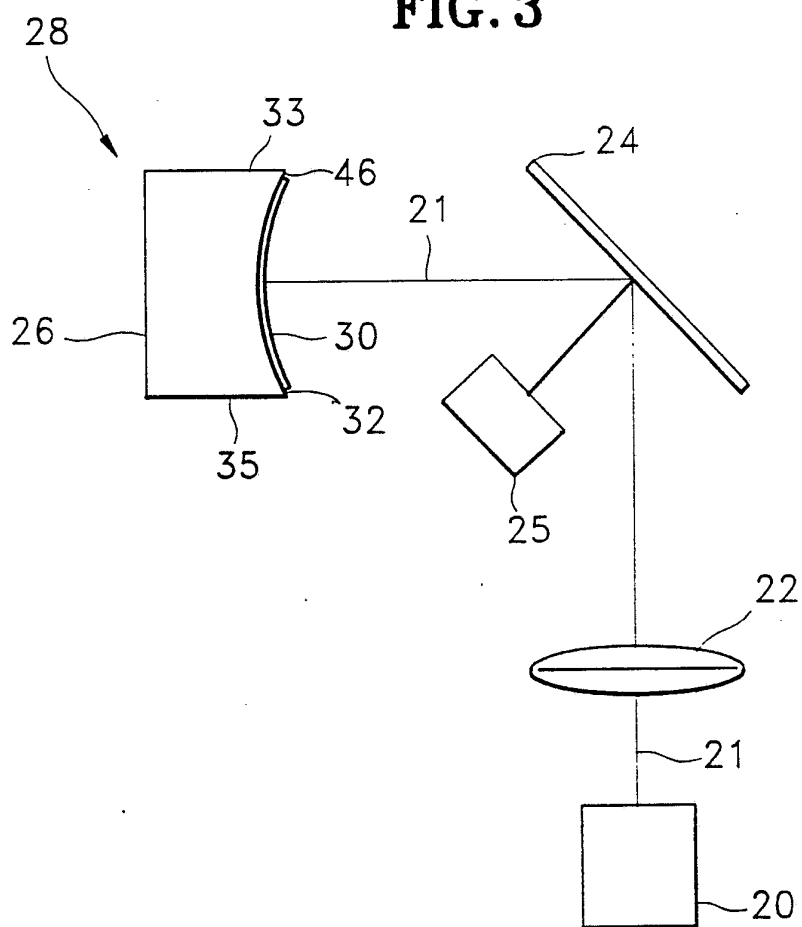
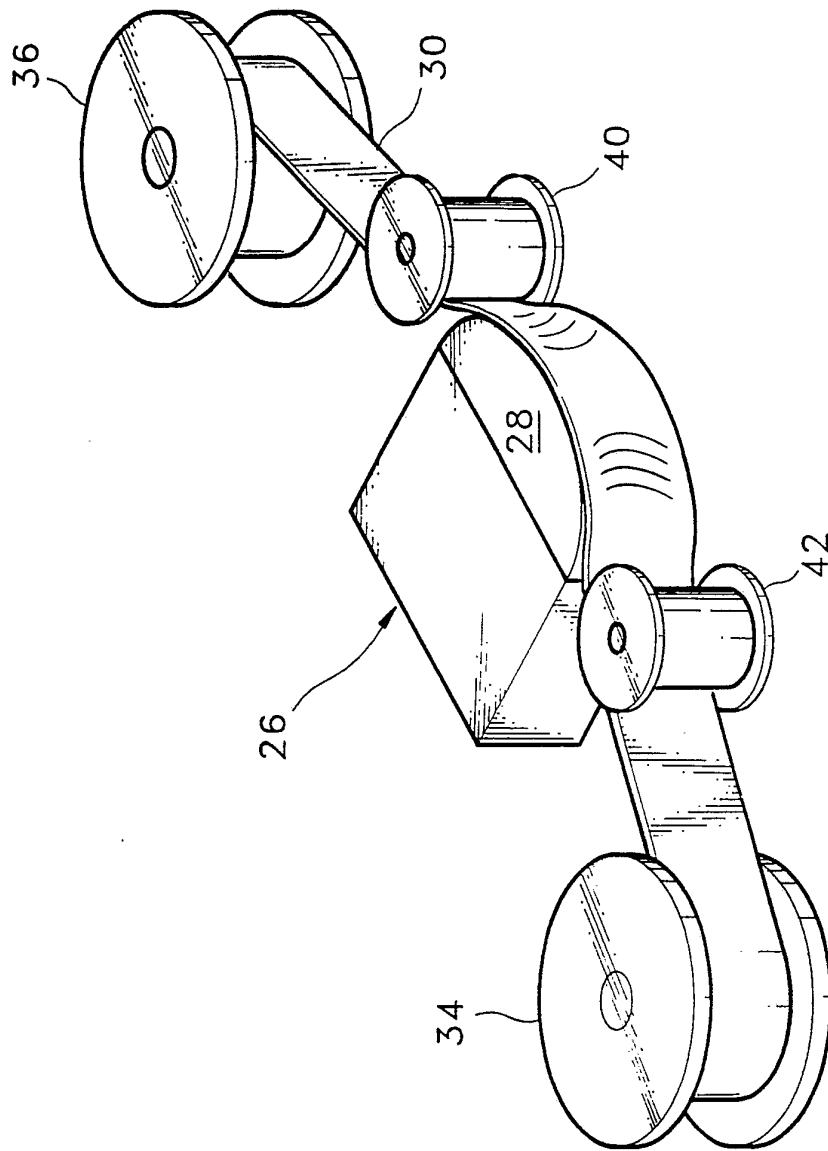

FIG. 2



## INTERNATIONAL SEARCH REPORT

International application No.

PCT/KR 92/00057

## A. CLASSIFICATION OF SUBJECT MATTER

IPC<sup>5</sup>: G 11 B 7/24, 7/00, 15/60

According to International Patent Classification (IPC) or to both national classification and IPC

## B. FIELDS SEARCHED

Minimum documentation searched (classification system followed by classification symbols)

IPC<sup>5</sup>: G 11 B 7/24, 7/00, 15/60

Documentation searched other than minimum documentation to the extent that such documents are included in the fields searched

Electronic data base consulted during the international search (name of data base and, where practicable, search terms used)

DERWENT - WPIL

## C. DOCUMENTS CONSIDERED TO BE RELEVANT

Category*	Citation of document, with indication, where appropriate, of the relevant passages	Relevant to claim No.
A	EP, A2, 0 146 004 (BURROUGHS CORP.) 26 Juni 1985 (26.06.85), fig. 4,5,9,10,11,12.	1,4,8,16
A	DE, A1, 2 816 372 (N. V. PHILIPS' GLOEILAMPENFABRIEKEN) 02 November 1978 (02.11.78), fig. 6,7,8,12,13.	1,4,8,16
A	DE, A1, 2 702 651 (N. V. PHILIPS' GLOEILAMPENFABRIEKEN) 11 September 1977 (11.08.77), fig. 3-6.	1,4,8,16
	----	

 Further documents are listed in the continuation of Box C. See patent family annex.

\* Special categories of cited documents:

"A" document defining the general state of the art which is not considered to be of particular relevance

"E" earlier document but published on or after the international filing date

"L" document which may throw doubts on priority claim(s) or which is cited to establish the publication date of another citation or other special reason (as specified)

"O" document referring to an oral disclosure, use, exhibition or other means

"P" document published prior to the international filing date but later than the priority date claimed

"T" later document published after the international filing date or priority date and not in conflict with the application but cited to understand the principle or theory underlying the invention

"X" document of particular relevance; the claimed invention cannot be considered novel or cannot be considered to involve an inventive step when the document is taken alone

"Y" document of particular relevance; the claimed invention cannot be considered to involve an inventive step when the document is combined with one or more other such documents, such combination being obvious to a person skilled in the art

"&amp;" document member of the same patent family

Date of the actual completion of the international search

18 January 1993 (18.01.93)

Date of mailing of the international search report

21 January 1993 (21.01.93)

Name and mailing address of the ISA/ AT  
AUSTRIAN PATENT OFFICE  
Kohlmarkt 8-10  
A-1014 Vienna  
Facsimile No. 0222/53424/535

Authorized officer

Berger e.h.

Telephone No. 0222/53424/454

**INTERNATIONAL SEARCH REPORT**  
Information on patent family members

International application No.

PCT/KR 92/00057

In Recherchenbericht angeführtes Patentedokument Patent document cited in search report Document de brevet cité dans le rapport de recherche	Datum der Veröffentlichung Publication date Date de publication	Mitglied(er) der Patentfamilie Patent family member(s) Membre(s) de la famille de brevets	Datum der Veröffentlichung Publication date Date de publication
EP A2 146004	26-06-85	DE C0 3479936	02-11-89
		EP A3 146004	28-05-86
		EP B1 146004	27-09-89
		JP A2 60193154	01-10-85
		JP B4 61029059	04-07-86
DE A1 2816372	02-11-78	AT A 2919778	15-01-80
		AT B 358294	25-08-80
		AU A1 35400778	01-11-79
		AU B2 512776	23-10-80
		BE A1 866347	25-10-78
		DD C 135545	09-05-79
		DK A 1759778	28-10-78
		ES A1 469103	01-01-79
		FR A1 2389191	24-11-78
		GB A 1603234	18-11-81
		IT A0 7822686	24-04-78
		IT A 1095320	10-08-85
		JP A2 53135310	25-11-78
		NL A 7704581	31-10-78
		SE A 7804622	28-10-78
US A 4199796	22-04-80		
DE A1 2702651	11-08-77	AR A1 211722	28-02-78
		AT A 620777	15-08-78
		AT B 349226	26-03-79
		AU A1 21820777	10-08-78
		AU B2 508651	27-03-80
		BE A1 851021	02-08-77
		BR A 7700620	04-10-77
		CA A1 1090470	25-11-80
		CH A 610433	12-04-79
		DD C 129590	25-01-78
		DK A 413777	05-08-77
		ES Y 226107	16-11-77
		ES Y1 226107	13-12-77
		FR A1 2340596	02-09-77
		GB A 1573022	13-08-80
		IT A 1076657	27-04-85
		NL A 7601106	08-08-77
		NZ A 183229	21-02-80
		SE A 7701029	05-08-77
		US A 4100585	11-07-78
ZA A 7700236	30-08-78		