

Nov. 11, 1969

L. R. BENNER, SR

3,477,597

APPARATUS AND METHOD FOR OPENING CANS WITH TEAR STRIPS

Filed Sept. 12, 1966

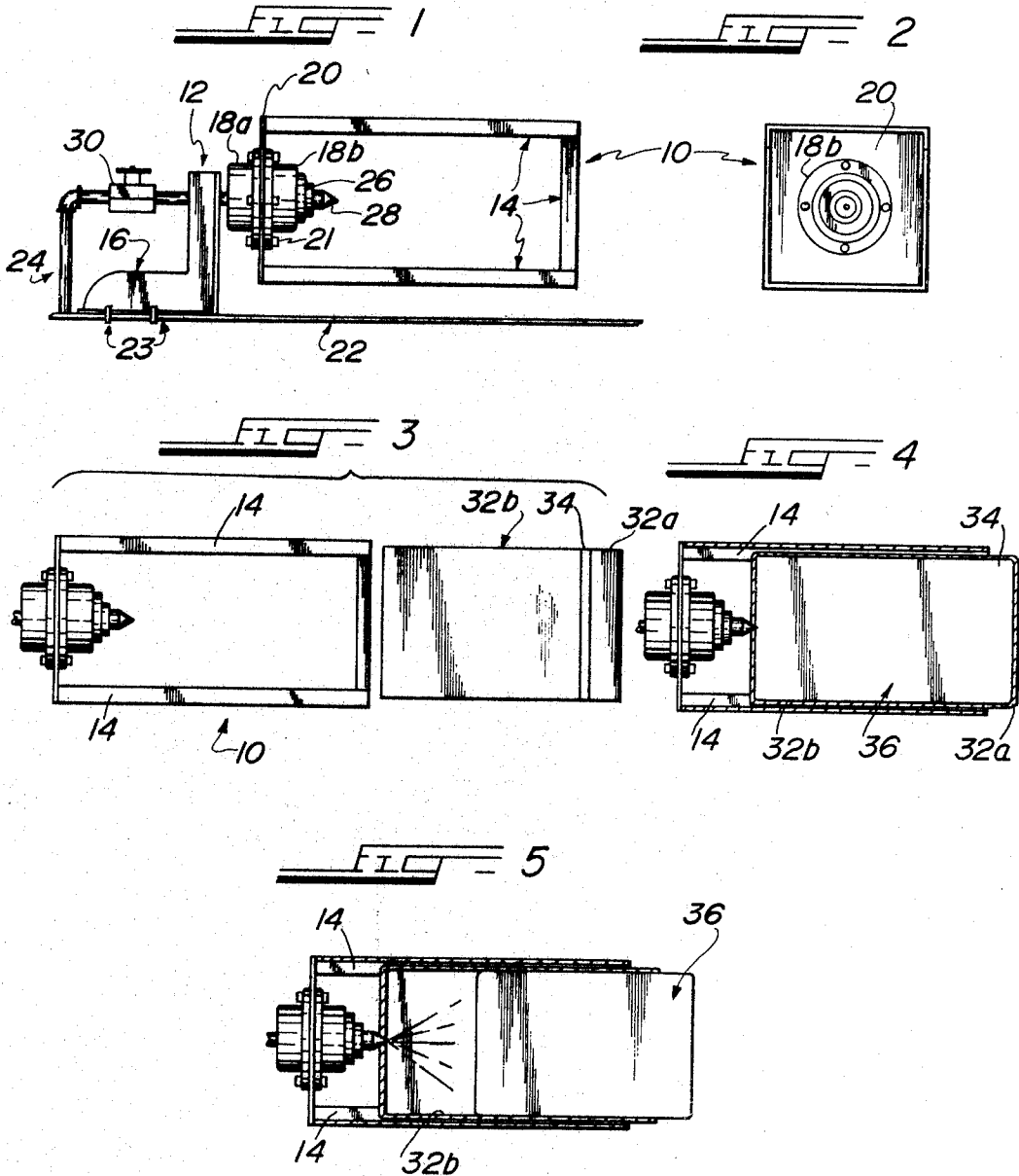

INVENTOR.

LLOYD ROBERT BENNER, SR.

BY

Carl C. Batz

ATTORNEY.

1

2

3,477,597

APPARATUS AND METHOD FOR OPENING CANS WITH TEAR STRIPS

Lloyd Robert Benner, Sr., Nampa, Idaho, assignor to Armour and Company, Chicago, Ill., a corporation of Delaware

Filed Sept. 12, 1966, Ser. No. 578,548

Int. Cl. B65b 69/00; B67b 7/24

U.S. Cl. 214-304

8 Claims

ABSTRACT OF THE DISCLOSURE

A rotatably mounted frame adapted to receive and hold in a fixed position a can having a tear strip, the frame providing access to the tear strip. One end of the frame is provided with an air needle adapted to puncture the can upon insertion of the same in the frame and eject the contents after removal of the tear strip.

This invention relates to an apparatus and method for opening cans, and more specifically to a freely rotatable frame and a method for using same to open cans provided with tear strips.

It is customary in the processed meat industry to package and ship processed meats in metal cans provided with tear strips for opening the cans. Frequently the meat is shipped from one place to another and must be removed from the cans and processed further before being placed in a suitable condition for sale to the consumer. For example, in slicing processed meats, it is customary to make the meat in loaf form at one plant and ship it to another plant for slicing and retail packaging and distribution. These loaves are usually shipped in long square metal cans provided with a metal tear strip at one end.

When the loaf is ready for slicing, the tear strip is torn free and unwound by hand from the can leaving a cover or top on the can that is easily removed from the loaf. The remaining section of the can is then separated from the loaf by being shaken vigorously by hand. A thin layer of gelatin usually exists between the loaf and the can and it acts as a lubricant to facilitate the separation. When dealing with a large volume of cans, however, this procedure becomes very tedious and adds substantially to the time required to further process the meat.

Accordingly, it is an object of this invention to provide a new method and apparatus for use in opening cans having tear strips that will tremendously increase the rate at which they can be opened.

Another object of the invention is to provide a new method and apparatus that will not only increase the rate at which cans having tear strips can be opened, but will also simultaneously separate the can from the loaf of meat.

Other objects and advantages of the invention will become apparent as the specification proceeds.

The apparatus and method of the instant invention generally comprises a rotatably mounted frame adapted to fixedly hold a can having a tear strip which is grasped and pulled away from the can to cause the can and the frame to rotate until the tear strip is substantially free of the can permitting the cover to be removed therefrom. Another embodiment of the instant invention has the rotatably mounted frame in combination with an air needle for piercing the can after being introduced into the frame and for injecting air in the can to separate the can from its contents by the pressure created thereby.

The invention will be more specifically described in connection with the accompanying drawings, in which:

FIG. 1 is a side view of the apparatus of the instant invention.

FIG. 2 is a view of the right-hand end of said apparatus.

FIG. 3 is a top view of said apparatus and a can about to be introduced into the frame.

FIG. 4 is a top view in partial section of said can in the frame being pierced by the air needle.

FIG. 5 is a top view in partial section of the can being separated from its contents by the air pressure from said air needle.

Referring now to the drawings, and particularly to FIGS. 1-5, the apparatus of the instant invention generally comprises a frame 10 rotatably supported by mounting means 12. The mounting means 12 comprises a bracket 16, and hubs 18a and 18b which are rotatably mounted on the gas or air line 24 passing through the bracket 16 and the hubs 18a and 18b. The mounting means 12 is made stationary by fixing the bracket 16 to a work bench 22 with bolts 21.

The frame 10 is comprised of thin steel bars 14 welded together to form the open box-like configuration depicted in the drawings. The frame 10 has the same long, square shaped configuration of the cans to be opened and the dimensions of the frame 10 are slightly in excess of the cans so the cans can be easily inserted therein but yet be close enough for a snug fit to prevent excessive movement during rotation. One end of the frame 10 is left open for the passage therein of the cans and the other end is closed with an end plate 20 which is welded thereto and which serves as a base to which the hubs 18a and 18b are fixed to each side by bolts 21. The plate 20 has a hole (not shown) in its center to allow for the passage of the air line 24 about which the frame 10 rotates.

The air line 24 terminates inside the frame 10 and connects to a reducer 26 which communicates with said air line 24. The reducer 26 in turn is fixedly connected to a gas or an air needle 28 and communicates therewith. The air needle 28 is along the same axis of rotation as the frame 10 and is provided with a sharp enough point to puncture a can when pressed against the needle 28 by hand.

The method for opening one of the cans with the freely rotatable frame 10 is as follows: First, the can 32 is pushed by hand into the open end of the frame 10 until it is up against the air needle 28. The can 32 is positioned so its end furthest from the metal tear strip enters the frame 10 first. The can 32 may be pushed by hand up against the hollow air needle 28 until it punctures and enters the can 32. The valve 30 to the air line 24 may be turned on (or can be left on continuously) to permit the air to enter the can 32 and create a pressure therein.

Prior or subsequent to the puncturing step the tear strip 34 may be grasped and pulled away from the can 32. This causes the frame 10 and can 32 to rotate together and allows the tear strip 34 to be torn free of the can 32 in one quick, continuous movement.

When the tear strip 34 is free of the can 32, the can breaks open into a short top section, 32a and a long bottom section, 32b. The top section 32a is easily removed from the loaf 36 by hand or may even fall off of its own accord. The loaf 36 is then free to be simultaneously pushed out of the bottom section 32b by the force of the air pressure.

In the preferred embodiment of the invention the frame is shorter than the length of the can to provide free access to the tear strip which will project beyond the end of the frame and not be obstructed thereby. However, the invention is not limited to a frame shorter than the can but comprehends a frame of any length that will provide access to the tear strip and not hinder the tear strip from being torn free of the can as described hereinabove.

The apparatus and method of the instant invention are

well suited for large scale commercial processed meat operations where large volumes of cans must be opened for further processing of the meat. However, the invention is not limited to this environment but can be utilized in any setting where cans having tear strips are to be separated from their contents.

The benefits and advantages of the apparatus and method of the instant invention are considerable when compared with the prior mode of operation. Cans with tear strips will not have to be opened any longer by the slow, tedious procedure of unwinding the tear strip by hand from the can and shaking out its contents. For by use of the present invention, the can and its contents are carefully separated from each other in two quick-steps—insertion of can in the frame until it is punctured with the air needle, and tearing the tear strip from the can in the freely rotatable frame in one continuous uninterrupted movement.

While the embodiment of the invention chosen herein for purposes of the disclosure is considered to be preferred, it is understood that this invention is intended to cover all changes and modifications on the disclosed embodiment which fall within the spirit and scope of the invention.

I claim:

1. The method of opening a can having a tear strip comprising the steps of fixedly positioning said can in a freely rotatable holding means, grasping and pulling one end of said tear strip away from said can to cause said can and the means in which it is positioned to rotate in the same direction until said tear strip is substantially free of said can, and removing the cover from said can.

2. The method of opening a can having a tear strip and separating said can from its contents comprising the steps of fixedly positioning said can in a freely rotatable holding means, grasping and pulling one end of said tear strip away from said can to cause said can and the means in which it is positioned to rotate in the same direction until said tear strip is substantially free of said can removing the cover from said can, piercing said can and injecting air therein to create pressure, and separating said can from its contents by said pressure.

3. The method of claim 2 wherein the piercing and air injection step is performed before the step of removing the tear strip from said can.

4. The method of claim 2 wherein said piercing and air injection step is performed simultaneously with the step of removing said tear strip from said can.

5. The method of claim 2 wherein said piercing and air injection step is performed subsequent to the step of removing said tear strip from said can.

6. A can opening and unloading device for a container

having a tear strip adjacent the periphery thereof, said tear strip being tearable from the container for removing one end thereof, said device comprising stationary mounting means, a rotatable frame rotatably mounted on said mounting means, said frame receiving and fixedly holding said container with said tear strip projecting from said frame, removal of said tear strip effecting rotation of said frame on said mounting means, and gas line means connected to said frame for directing gas internally of said container upon positioning of said container in said frame and removal of said tear strip and said one end to thereby aid in ejecting the contents of the container.

7. A can opening and unloading device according to claim 6 wherein said gas line means is fixedly mounted on said mounting means, said gas line means including gas needle means projecting therefrom into the interior of frame along the rotation axis thereof whereby positioning of said container in said frame results in puncturing one end of said container by said gas needle means, said frame being shorter in length than said container whereby said tear strip projects from one end of said frame.

8. A container opening apparatus for opening a container provided with a tear strip, the tear strip being tearable from the container for removing one end thereof, said apparatus comprising: a stationary mounting means adapted to be fixed to a supporting surface, and a rotatable frame rotatably supported on and rotatable relative to said stationary mounting means; said frame including holding means to fixedly receive and hold a container stationary relative to said frame during removal of the tear strip whereby removal of the tear strip results in rotation of said frame and the container in the same direction relative to said stationary mounting means.

References Cited

UNITED STATES PATENTS

416,536	12/1889	Young et al.	220—54
1,557,610	10/1925	Peters	220—54
1,704,234	3/1929	Young	220—54
2,795,344	6/1957	Lubischer	214—304
2,946,470	7/1960	McFarlane	214—304
2,984,375	5/1961	Gardner	214—305
3,008,594	11/1961	Toennies	214—304
2,703,187	3/1955	Druilhet	220—52
2,780,387	2/1957	Hertzfeldt	220—52

JOHN F. CAMPBELL, Primary Examiner

D. C. REILEY, Assistant Examiner

U.S. Cl. X.R.

29—234, 427; 113—1; 214—152, 310; 220—52, 54