

(No Model.)

A. SJOGREN.
MINING PUMP.

No. 305,972.

Patented Sept. 30, 1884.

Fig 3.

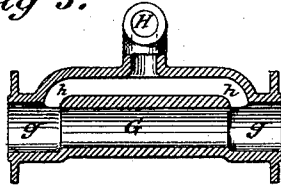

Fig 1.

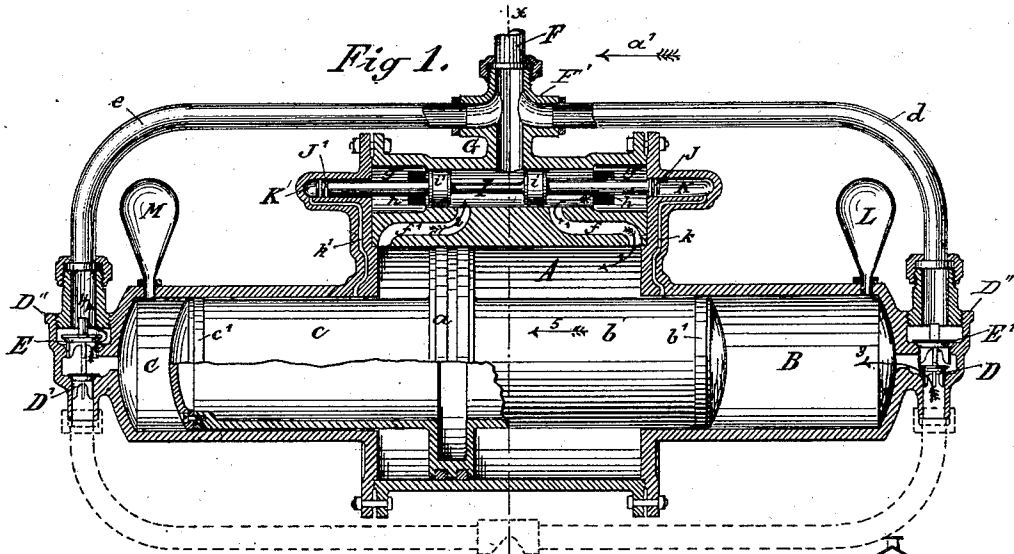

Fig 2.

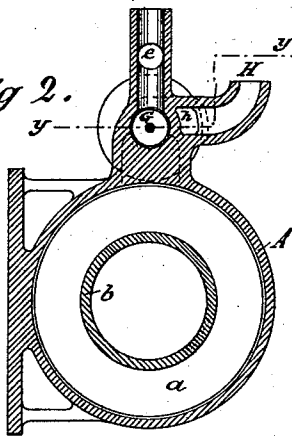
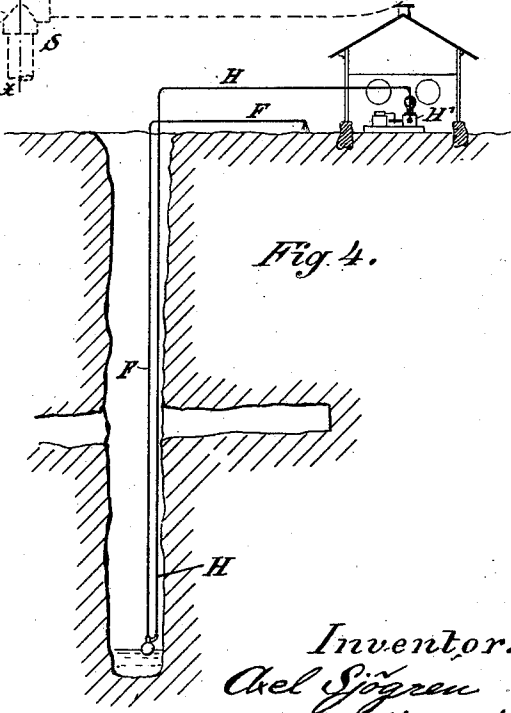

Fig 4.



Witnesses:
Edward Siefert
Robt W Matthews.

Inventor:
Axel Sjogren
by A. M. Almqvist
Attorney.

UNITED STATES PATENT OFFICE.

AXEL SJOGREN, OF DENVER, COLORADO.

MINING-PUMP.

SPECIFICATION forming part of Letters Patent No. 305,972, dated September 30, 1884.

Application filed May 9, 1883. (No model.)

To all whom it may concern:

Be it known that I, AXEL SJOGREN, a citizen of Sweden, and a resident of Denver, in the county of Arapahoe and State of Colorado, have invented certain new and useful Improvements in Mining-Pumps, of which the following is a specification.

My invention relates to pumping apparatus for raising water from great depths, and thus specially applicable for pumping water out of mines.

The invention comprises an improved construction of a pump to be placed at the bottom of a shaft or well of a mine, and improved means for operating the same (by hydraulic pressure) from a steam-pump or other motor above ground without the use of long wooden timbers to form working connection between the motor and the lower pump, and enabling the transmission of the power into any bends, angles, or horizontal passages connected with the shaft without the use of any expensive crank-wheels, such as are now generally used in connection with such long wooden timbers, together with the so-called "Cornish pump."

The object to be obtained is not only cheapness and convenience in manipulation, saving of space and of labor in keeping old movable parts in working order, but also the saving of a good deal of power which in pumps as heretofore constructed is caused by friction in the guides, &c., along the wooden means of transmission.

In the accompanying drawings, Figure 1 represents a longitudinal vertical section of a mining-pump constructed according to my present invention, and intended to be used near the bottom of a mine. Fig. 2 is a vertical central cross-section of the same as seen in the direction of the arrow 1 in Fig. 1. Fig. 3 is a horizontal detail section taken on the line *y y* of Fig. 2. Fig. 4 is a general view illustrating the arrangement of the motor above ground and the pump at the bottom of the mine with the operating-pipe and the discharge-pipe.

The pump has one central cylinder, A, connecting with two lateral smaller cylinders, B C, the said three cylinders being preferably arranged in the same axial line.

In the central cylinder, A, is fitted a tight-

working piston, *a*, which is formed in one piece with two lateral hollow plungers, *b c*, which latter are provided around their outer ends with packing-rings *b' c'*, by which they are arranged to work tightly in the smaller lateral cylinders, B C, respectively. The said cylinders are provided with air-bells L M, and are provided at their extreme ends with suitable valve-chests D', integrally cast with the cylinders, and containing the ordinary sets of puppet-valves D E and D' E', for regulating a constant supply of water, as in ordinary double-acting pumps. The said valve-chests are connected by pipes *d e* to a common pipe, F, by means of the three-way casting F', the lower end of which also connects with a valve-chest, G, of the pump, and which pipe F thence leads up through the shaft to discharge the water from the bottom of the mine at any suitable place above the ground, as shown in Fig. 4.

The inlets to the valve-chests at the end of the lateral cylinders B C are preferably connected by separate pipes to one common suction-pipe, S, as indicated by the dotted lines in Fig. 1.

The force for working the piston *a* in the cylinder A, for operating the plungers *b c*, is obtained by water led through a pipe, H, by the motive power of a steam-pump, H', to and by means of a channel, *h*, formed in the casting of the valve-chest G, the ends of the said channel entering the enlarged ends *g* of the said cylindrical valve-chest G, as shown in Figs. 1 and 3.

The pump-operating valve consists simply of a rod, I, having packed pistons *i i'* fitted to work in the valve-chest G between the inlet-openings of the channel *h*, the said rod I extending laterally beyond the entire length of the valve-cylinder G and its enlargement *g*, and being provided around its extreme ends with packing-rings J J', working tightly in axial cylindrical extensions K K' of the valve-chest G. From the ends of the said tubular extensions K K' little channels *h' h'* are formed in the castings, said channels leading into the plunger-cylinders B C near their junction with the central cylinder, A.

That portion of the valve-chest G in which the pistons *i i'* work is connected with the cyl-

inder A by ordinary ports or channels, $f f'$, in the manner usual in steam-pumps.

The operation is as follows, (referring to Fig. 1:) The water from the pump H' above the ground enters by means of the passages h and f (as indicated by arrows 1) into the cylinder A, moving the piston a and plungers b c in the direction of arrow 5. From the opposite side of the piston a the water is discharged through the channel f' , as indicated by arrow 2, into the space of the cylinder G between the pistons $i i'$, and thence into the discharge-pipe F. The atmospheric pressure raises the water through the suction-pipe S and the valve D in the direction of the arrow 3 into the plunger-cylinder B, while at the same time the water is discharged from the plunger-cylinder C through the valve E in the direction of the arrow 4 by way of the pipe e into the discharge-pipe F, the valves E' and D' being meanwhile closed. The water entering the cylinder A through the port f thence enters, by means of the small channel h , into the end cylinder, K, in which the packing-rings J upon the valve-rod I work, thus keeping the full working pressure of the pump upon that end of the valve-rod I, while at the other end, J', the pressure is less, being dependent upon the weight only of the water column in the discharge-pipe F, which, by the port f' , the forward space of the cylinder A, and the channel k , communicates with the end cylinder, K', in which the packing-rings J' of the valve-rod I work, and consequently retain the valve I in the position shown in Fig. 1; but when now the packing-ring b' , during the progress of the piston a , has passed the small channel h , communication will instantly be established between the said small channel h and the suction-pipe, in which of course the pressure is less, being only due to vacuum. The pressure upon the end J' of the valve I will then become greater, and consequently the valve will be pushed in the opposite direction until the pistons $i i'$ have passed the adjacent opening of the ports $f f'$, respectively. The water from the pipe H will then be forced in through the port or channel f , forcing the piston a in the opposite direction, and water remaining in the cylinder A from the previous stroke will be forced out, by way of the channel f , into the discharge-pipe F, the puppet-valves D E will be closed, the valves D' E' will be open, and the water drawn into the cylinder C and expelled from the cylinder B, by way of the pipe d , into the common discharge-pipe F. When, on the return-stroke, the packing-ring c' has passed the channel k' , (and thus the said channel will be placed in communication with the suction-pipe,) the pressure on the end J of the valve I will predominate and force the valve to again resume the position shown in Fig. 1, and so on continuously.

It will be seen that the pressure upon the outer sides of the pistons $i i'$ is always balanced, the water entering, as it does, from the pipe H to both of the said sides simultaneously by way of the channel h . By thus working the piston by water-pressure from a motor, H', above ground, through a pipe, H, it is evident that the pump may be placed in any angular bend or passage in the mine without the expense and labor of timber connections, as the pipe H may easily be formed into any bends, and provided with extensions to convey the power conveniently to any place desired.

Having thus described my invention, I claim as new and desire to secure by Letters Patent—

1. In an isolated mining-pump consisting of the cylinders A B C, the cylinder A, provided with a valve-chest, G, having enlarged ends g , connected by a lateral passage, h , which communicates with the pipe H, ports $f f'$, and three-way casting F', the said cylinder and chest, with its ports and attachments, being formed out of one piece of metal at one and the same operation, as set forth.

2. In a mining-pump designed to be operated by hydraulic or pneumatic pressure from a distant point, and in combination with the central cylinder thereof, constructed substantially as set forth, the plunger-cylinders B C, each provided, respectively, with the tubular extensions K K', channels $k k'$, and valve-chests D', all integrally formed, and constructed and arranged to operate substantially as and for the purposes described.

3. In a mining-pump, in combination with the cylinders and chest, the bifurcated suction-pipe S and bifurcated discharge-pipe F, communicating with said chest, both sets connected to the opposite ends of said cylinders, and having located between each set and the cylinder a puppet-valve, substantially as and for the purpose specified.

4. In a double-acting pump, in combination with the lateral cylinders B C and central cylinder, A, of larger diameter, the reciprocating tubular plungers $b c$, provided with a central portion, a , (peripherally grooved to receive packing-rings,) all cast integral, said plungers having end caps, and an annular groove between said caps and the ends of the plungers, to receive packing-rings, and constructed to work, respectively, in said cylinders, as and for the purpose set forth.

In testimony that I claim the foregoing as my invention I have signed my name, in presence of two witnesses, this 25th day of April, 1883.

AXEL SJOGREN.

Witnesses:

CHARLES M. DAY,
S. P. SUNNERGREN.