

W. BARTHOLOMEW & D. J. PHILLIPS.
MOTOR STOPPING DEVICE.

APPLICATION FILED SEPT. 27, 1909.

997,228.

Patented July 4, 1911.

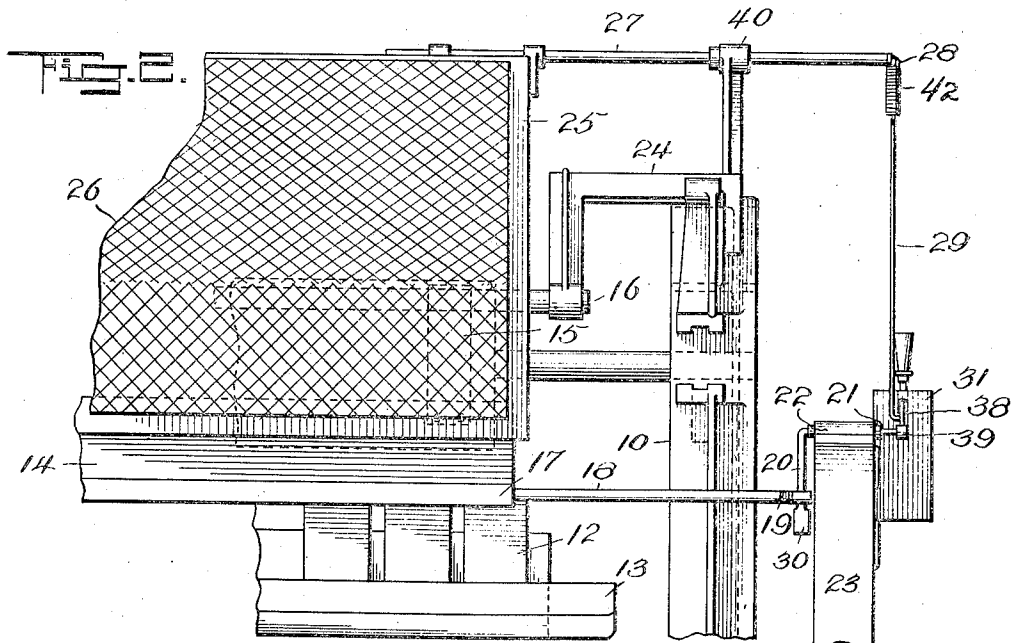
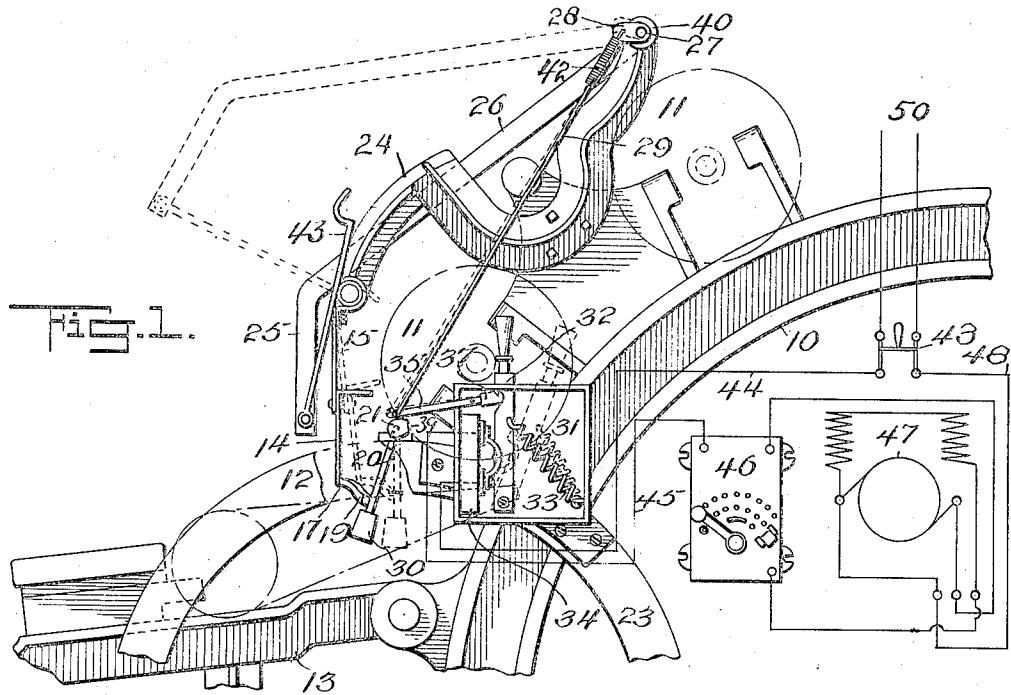

WITNESSES:
Wm. F. Roy Co.
Alfred T. Sage.

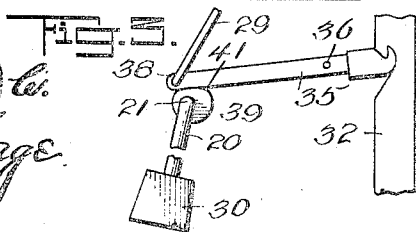

INVENTORS
William Bartholomew, Jr.
David J. Phillips
E. B. Stetling
Attorney

UNITED STATES PATENT OFFICE.

WILLIAM BARTHOLOMEW AND DAVID J. PHILLIPS, OF CHICAGO, ILLINOIS, ASSIGNORS
TO TROY LAUNDRY MACHINERY COMPANY, OF CHICAGO, ILLINOIS, A CORPORATION
OF NEW YORK.

MOTOR-STOPPING DEVICE.

997,228.

Specification of Letters Patent.

Patented July 4, 1911.

Original application filed August 9, 1909, Serial No. 512,101. Divided and this application filed September 27, 1909. Serial No. 519,768.

To all whom it may concern:

Be it known that we, WILLIAM BARTHOLOMEW and DAVID J. PHILLIPS, citizens of the United States, residing at Chicago, county of Cook, State of Illinois, have invented certain new and useful Improvements in Motor-Stopping Devices, of which the following is a specification, reference being had therein to the accompanying drawing.

This invention relates to a motor stopping device for machinery and particularly to a construction controlled by the movements of an operator in approaching a dangerous moving portion of a machine, and comprises a division of our application filed August 9, 1909, Serial No. 512,101.

The invention has for an object to provide movable safety devices normally held in position to protect the operator and when in such position to retain under tension a power controlling lever adapted to automatically release an electric switch when the safety devices are moved.

Other and further objects and advantages of the invention will be hereinafter set forth and the novel features thereof defined by the appended claims.

In the drawing—Figure 1 is a side elevation of the invention; Fig. 2 is a front elevation thereof; and Fig. 3 is a detail of the latch lever and its connections.

Like numerals of reference refer to like parts in the several figures of the drawing.

The invention is adapted for application to various types of machines having movable parts by which an operator is liable to be injured when coming in contact therewith. For the purpose of illustration it is herein shown in connection with a laundry mangle in which the numeral 10 designates the frame of the machine upon which the movable parts are mounted such as the rolls 11 with which a feeding apron 12 coöperates, this apron being extended from a feed bracket 13 of usual construction. Adjacent to the feed apron the guard board 14 is suspended by means of the hangers 15 pivoted upon the shaft 16 which may be mounted in any desired support for instance a bracket 24 on the machine frame. The free edge 17 of this board has extended from the end thereof an operating rod 18 provided with a strike portion 19 as shown in Fig. 1. This

rod is adapted in its inward movement with the board 14 to engage a crank arm 20 provided with a weight 30 and carried by a rock shaft 21 mounted in a bearing 22 upon any fixed part for instance a gear casing 23.

Coöperating with the board is a cover or screen 26 disposed above moving parts of the machine and having its frame 25 secured to a rock shaft 27 mounted in a bearing 40 on bracket 24 and provided at its extended end with a crank arm 28 carrying a spring 42 which is secured to a connector 29 extending to a releasing lever. This spring permits a movement of said lever by the board without resistance from the cover connections which yield during upward pressure upon the connecting rod of said lever. The cover frame has pivoted at its free end a brace 43 adapted to engage a fixed part of the machine for retaining the cover in raised position as shown in Fig. 1.

The guard board and cover are connected with an automatic switch 31 by which power to an electric driving motor may be cut off. In this switch the blade 32 is provided with the usual operating handle and normally held in open dotted line position by means of the tension spring 33. It is retained in contact with the switch block 34 by means of a latch lever 35 pivotally mounted at 36 and provided with a hooked end 37 to engage a coöperating part upon the switch blade or lever. The outer end 38 of this lever 35 is pivoted to the connector 29 controlled by the screen or cover 26 while beneath this end 38, a cam 39 is secured upon the rock shaft 21 and provided with a face 41 in contact therewith.

Any desired electrical connections may be provided, for instance as shown in Fig. 1 the main line wires 50 are provided with a cut out switch 43 from which a line 44 extends to one of the contacts upon the switch block 34. A line 45 extends from the opposite contact upon the switch block through the starter 46 to a driving motor from which a return line 48 extends to the switch 43.

In the operation of the invention it will be seen that pressure against the guard board by the hand of the operator in feeding goods to the machine produces an oscillation of the rock shaft and cam thereon which raises the outer end of the latch lever

to disengage the switch blade which is automatically shifted by its spring to cut off the current from the motor and thus prevent injury to the operator by contact with the traveling rolls or other parts of the machine. If the cover or screen be raised by an operator for the purpose of removing goods which may adhere to the rolls its rock shaft is oscillated so as to raise the outer end of the latch lever through the crank arm and connector and thus release the controlling switch. The latch lever is thus adapted for independent operation by either the inward movement of the board or the raising of the cover to release the switch blade and permit its automatic movement to cut off the power.

It will therefore be seen that the invention presents a simple and efficient construction adapted to be readily applied to any machine already in use by which the driving power may be automatically cut off by a slight movement of the safety devices, thus effectually protecting the operator from injury through contact with the moving parts of the machine.

Having described our invention and set forth its merits, what we claim and desire to secure by Letters Patent is—

1. In a motor stopping device, a driving motor, a controlling switch blade and co-operating contacts for said motor, a tension device for normally holding said switch blade out of engagement with said contacts, a latch lever pivoted intermediate of its ends and having one end adapted to temporarily engage and retain said blade in engagement with said contacts, a guard device for a movable machine element, and a rock shaft connected for operation by said guard device and provided with a cam member having a retaining face disposed to engage the opposite end of said lever from the switch blade and an operating face to actuate the lever.

2. In a motor stopping device, an electric motor, a switch lever in circuit with said motor, a latch lever engaging said switch lever, a guard board for active machine elements, means adapted to be actuated by said board for operating said latch lever, a cover member for active machine elements, and means actuated by said cover for operating said latch lever.

3. In a motor stopping device, an electric motor, a switch in circuit with said motor and provided with a movable member, means for automatically moving said member into open position, a pivoted latch lever adapted to engage said member at one end, a movable guard device for an active machine element, a rock shaft having a crank arm disposed to be actuated by said device in its movement, means carried by said rock shaft to engage and move the opposite end of said latch lever, a pivoted cover member

for an active machine element and provided with a crank arm, and a connection from said crank arm to said latch lever.

4. In a motor stopping device, a driving motor, a switch to control said motor and provided with a movable member, means for automatically moving said member into open position, a latch member adapted to retain said movable member in closed position, a movable guard device for an active machine element, a movable cover member for an active machine element, and connections from said guard device and cover member to said latch member whereby the latter may be independently operated by a movement of either said device or cover.

5. In a motor stopping device, a driving motor, a switch to control said motor and provided with a movable member, means for automatically moving said member into open position, a latch member adapted to retain said movable member in closed position, a movable guard device for an active machine element, a movable cover member for an active machine element, a connection from said guard device to said latch, and a yielding connection from said cover member to said latch.

6. In a motor stopping device, a driving motor, a switch to control said motor and provided with a movable member, means for automatically moving said member into open position, a latch member adapted to retain said movable member in closed position, a movable guard device for an active machine element, a movable cover member for an active machine element, a connection from said guard device to said latch, a crank arm carried by said cover member, a spring secured to said crank arm, and a connecting rod extending from said spring to said latch.

7. In a motor stopping device, a driving motor, a switch to control said motor and provided with a movable member, means for automatically moving said member into open position, a latch member adapted to retain said movable member in closed position, a movable guard device for an active machine element, a movable cover member for an active machine element, connections from said guard device and cover member to said latch member, and a pivoted brace carried by the free end of said cover member for supporting it in raised position.

8. The combination with the working elements of a machine, of a guard pivotally suspended in front thereof and having an extension, a power controlling lever, a latch cooperating therewith, and a cam arranged to have a moving contact with the latch and provided with a member movable with the cam and extended into the path of the guard extension substantially as specified.

9. The combination with the working elements of a machine, of a guard pivotally

suspended in front thereof and having an extension, a power controlling lever, a latch for retaining said lever in one position, a cam arranged beneath and in movable contact with the free end of the latch and having a weighted member movable with the cam and extending into the path of and disconnected with the guard extension.

In testimony whereof we affix our signatures in presence of two witnesses.

WILLIAM BARTHOLOMEW.
DAVID J. PHILLIPS.

Witnesses:

C. I. BELKNAP,
JNO. HOERMANN.
