

(No Model.)

4 Sheets—Sheet 1.

C. F. WURSTER.

MACHINE FOR MAKING LOOPED WIRE DEVICES.

No. 537,663.

Patented Apr. 16, 1895.

Fig. 1.

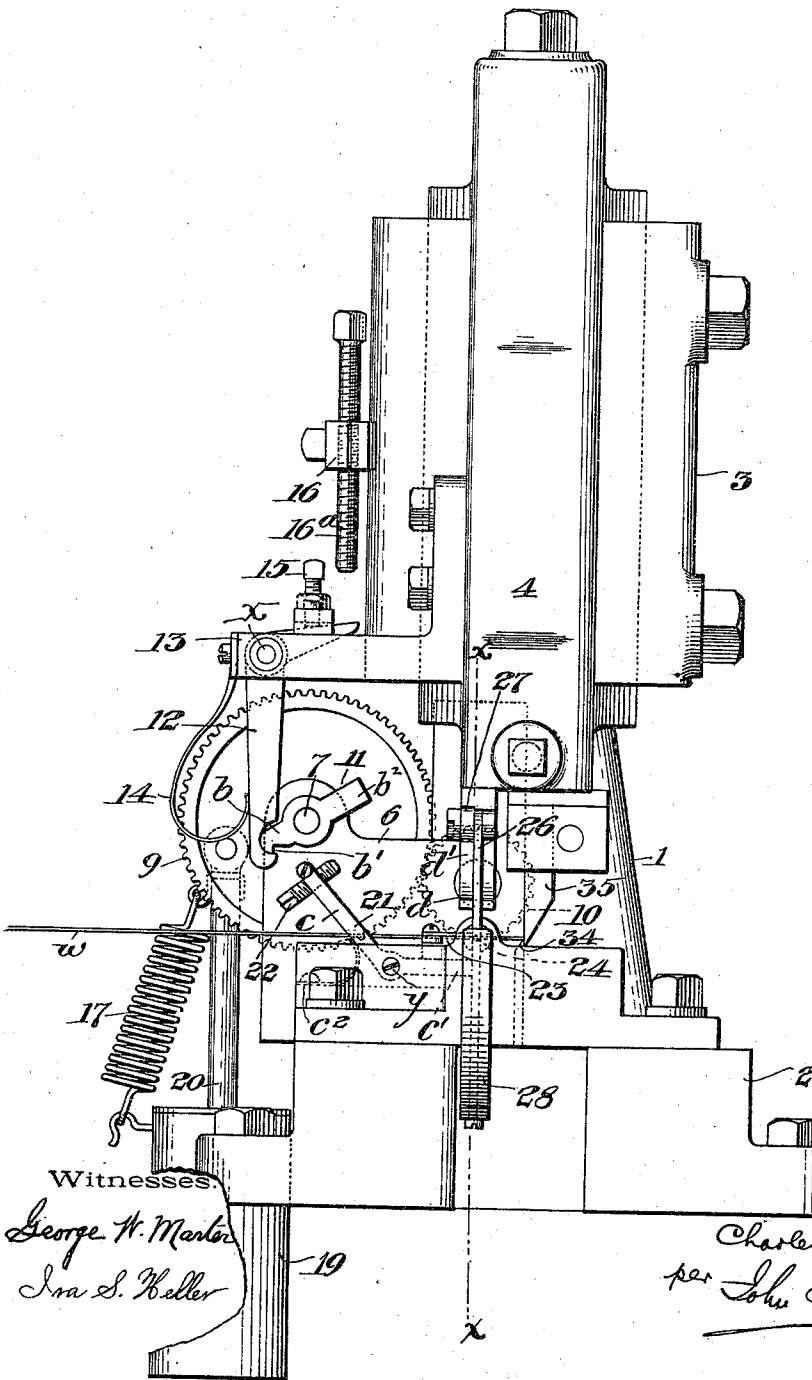

Witnesses.

George H. Mantor  
Ira S. Keller

Inventor.

Charles F. Wurster  
per John T. Nolan

Attorney.

C. F. WURSTER.

MACHINE FOR MAKING LOOPED WIRE DEVICES.

No. 537,663.

Patented Apr. 16, 1895.

Fig. 2.

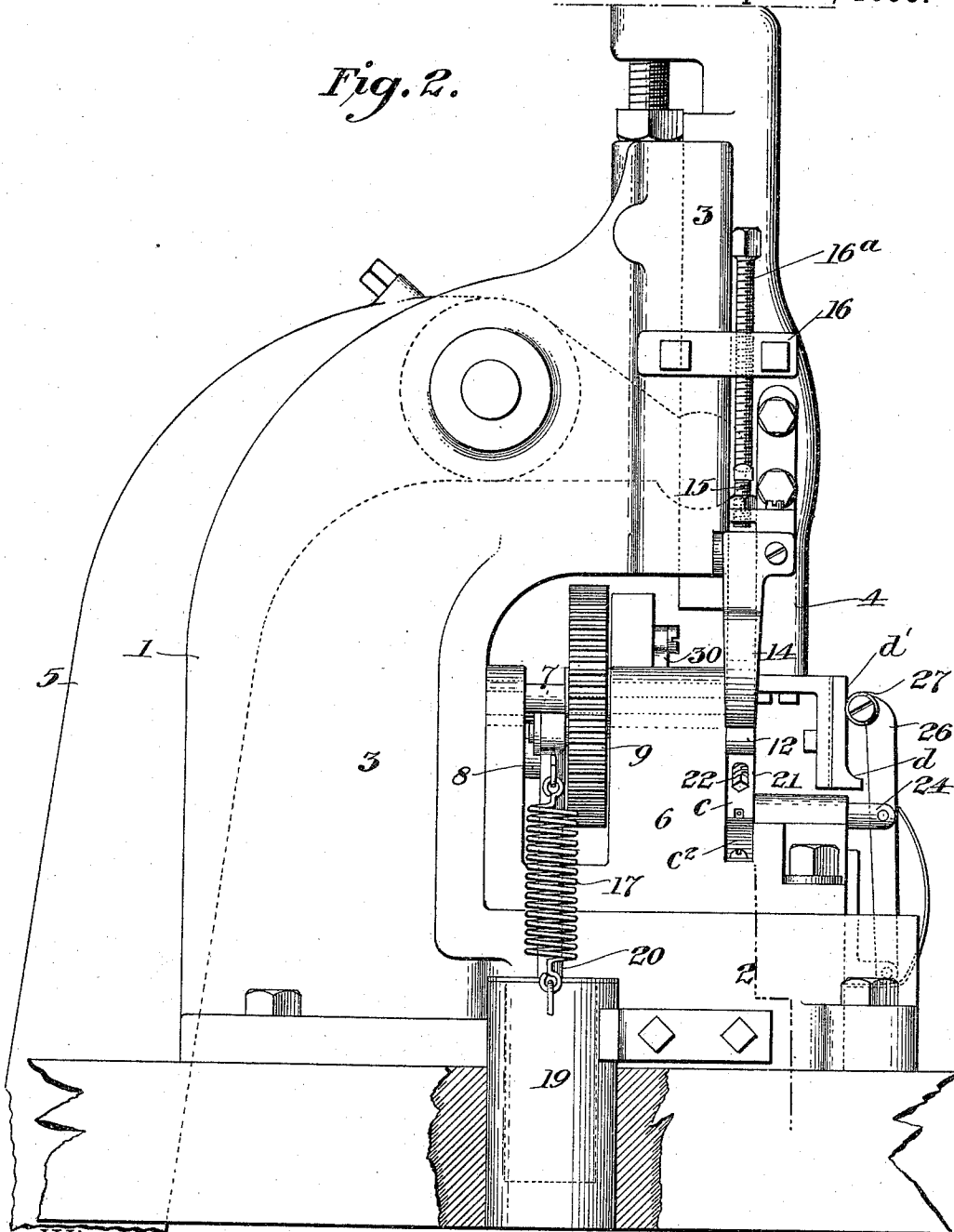

Witnesses.

George W. Martin.  
Ira S. Keller

Inventor.

Charles F. Wurster,  
per John B. Nolan

Attorney.

C. F. WURSTER.

MACHINE FOR MAKING LOOPED WIRE DEVICES.

No. 537,663.

Patented Apr. 16, 1895.

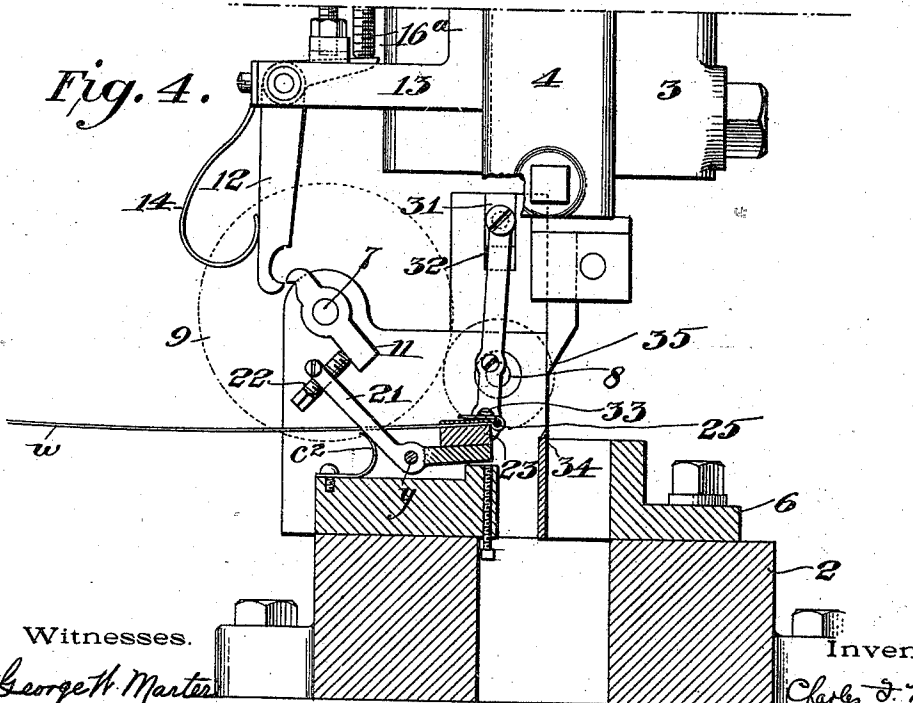
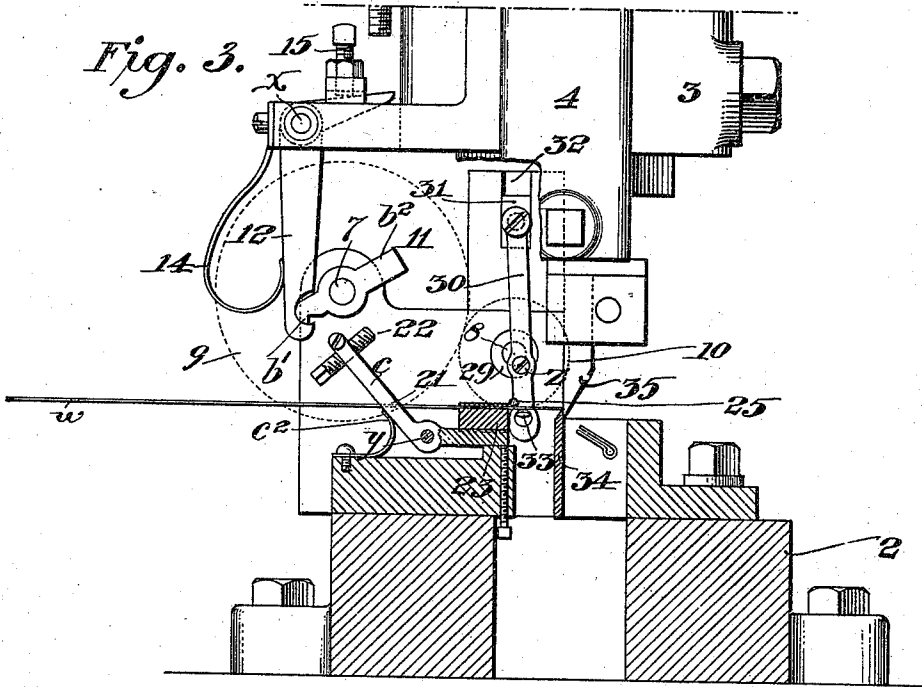

Witnesses.

*George H. Marten*  
*Ira S. Keller*

Inventor.

*Charles F. Wurster*

*per John T. Nolan*

Attorney.

C. F. WURSTER.

MACHINE FOR MAKING LOOPED WIRE DEVICES.

No. 537,663.

Patented Apr. 16, 1895.

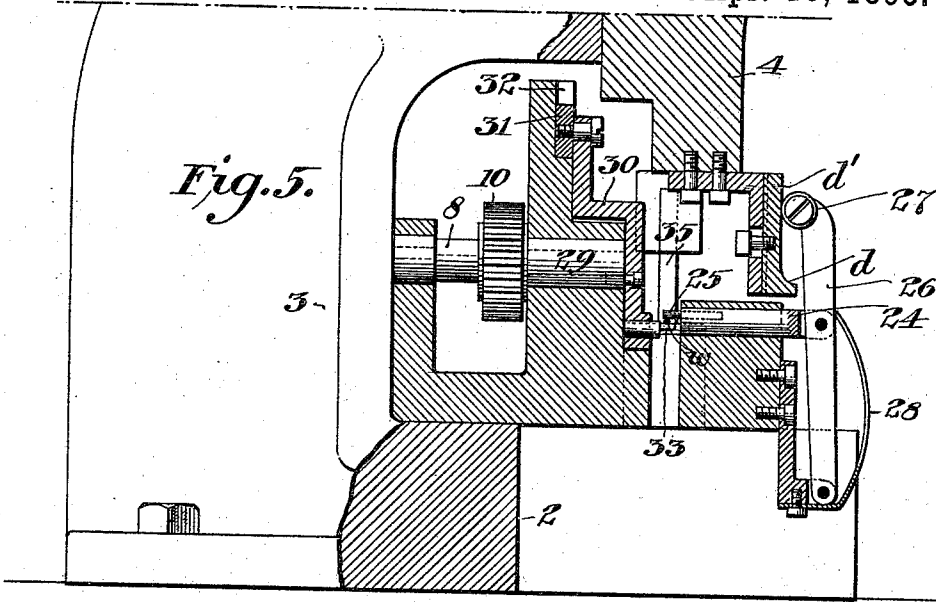

Fig. 6.

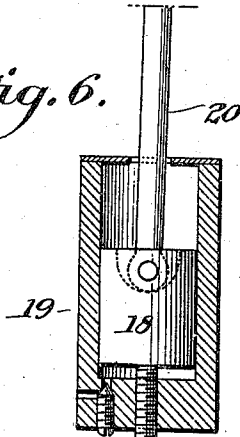
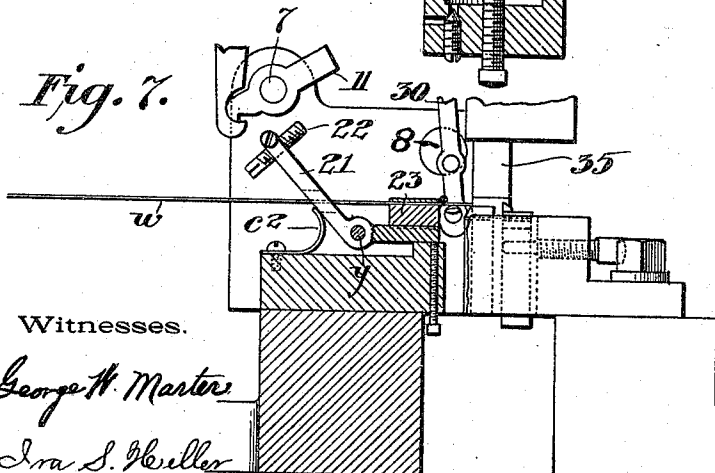

Fig. 7.



Witnesses.

*George H. Master*

*Ira S. Keller*

Inventor.

*Charles D. Wurster,*

*per John P. Noley*

Attorney.

# UNITED STATES PATENT OFFICE.

CHARLES F. WURSTER, OF PHILADELPHIA, PENNSYLVANIA, ASSIGNOR TO  
JAMES IRWIN BARNHURST, OF SAME PLACE.

## MACHINE FOR MAKING LOOPED-WIRE DEVICES.

SPECIFICATION forming part of Letters Patent No. 537,663, dated April 16, 1895.

Application filed September 26, 1894. Serial No. 524,158. (No model.)

*To all whom it may concern:*

Be it known that I, CHARLES F. WURSTER, a citizen of the United States, residing in the city and county of Philadelphia and State of Pennsylvania, have invented certain new and useful Improvements in Machines for Making Looped-Wire Devices, of which the following is a full, clear, and exact description, reference being had to the accompanying drawings, forming a part of this specification.

This invention relates to machines for bending, shaping and cutting wire to form looped devices for various purposes; among others, cotter pins for the ends of bolts, shafts, &c.; eye attachments for the tips of umbrella ribs, rods, &c., and temporary fasteners for sheets of paper, &c. In the said machines there are certain essential elements, to wit: a former; means for bending the end of the wire thereon; means for retracting the said former, and means for cutting off the bent or looped portion of wire.

The invention herein embraces improvements in the construction of the said elements, and in the general organization thereof, whereby the structure, as a whole, is simplified and its operation rendered more expeditious and efficient than heretofore, all of which will be hereinafter fully described and definitely claimed.

In the annexed drawings,—Figure 1 is a front elevation of the improved machine. Fig. 2 is a side elevation thereof. Fig. 3 is a sectional front elevation of the lower portion of the machine, showing the parts in their relative positions immediately upon the severance of the looped device from the wire, and preparatory to the formation of a succeeding device. Fig. 4 is a similar elevation showing the next succeeding positions of the parts in forming the device. Fig. 5 is a vertical section on the line  $x-x$  of Fig. 1. Fig. 6 is a detail section of the dash-pot device. Fig. 7 is a sectional elevation of a modification hereinafter referred to.

The numeral 1 represents the supporting frame, which is, in this instance, an ordinary "Ferracute" press, comprising the base 2; the standard 3; the vertically-reciprocative plunger 4 therein, and the foot lever 5 pivoted within said standard and operatively con-

nected with the plunger. Fitted to the base is a frame-work or housing 6 of appropriate construction, in which are mounted rearward of the plunger two horizontal shafts 7 and 8, bearing co-acting gear wheels 9 and 10 respectively. The forward end of the shaft 9 projects beyond the face of that portion of the frame-work in which it is mounted, and carries a small lever 11 which I shall term a trip-lever. One arm ( $b$ ) of this lever is provided with a hook or jaw  $b'$  with which is adapted to engage at predetermined intervals a similar jaw on the end of the depending arm of a bell-crank lever 12, as below explained. This bell-crank lever is fulcrumed, as at  $x$ , to a laterally-extending bracket 13 affixed to the plunger, the longer arm thereof being pressed normally inward by the action of a suitably-disposed spring 14 secured to said bracket. The upward movement of the shorter arm of the lever is determined by means of a set-screw 15 fitted to a suitable lug or projection on the bracket.

Secured to the standard 3 directly above the free end of the shorter arm of lever 12, is a piece 16 to which is fitted a vertically arranged set-screw 16<sup>a</sup> (or other vertically adjustable stop) to the end that during the upward stroke of the plunger the said shorter arm will abut against the screw and be depressed thereby. Normally the trip lever occupies the position shown in Fig. 1 of the drawings, so that when the plunger is depressed the depending arm of the lever grasps the jaw of the trip lever. Hence during the upward stroke of the plunger the lever 12 draws upward the engaged arm of the trip-lever until the shorter arm of lever 12 strikes the set-screw in its path, whereupon the said arm is depressed as above stated, and the longer arm, in consequence, is thrown outward to disengage it from the trip lever. See Fig. 4. In this way the gear 9 is partially turned and the movement communicated to the adjacent gear 10 for a purpose hereinafter appearing. When the trip lever is freed it is caused immediately to resume its former position, this action being effected by means of a suitably-disposed spring 17. In the present instance, the gear wheel 9 is connected with the piston 18 of an ordinary dash-pot 19

by means of a rod 20, the spring 17 being secured to said rod and to the side of the pot. Hence when gear 9 is turned, during the upward stroke of the plunger, it is moved against the tension of the spring, and, in consequence, when the trip lever is freed the spring returns the parts to their original position. The function of the dash-pot is to reduce the concussion otherwise incident to the recoil of the spring.

Pivoted to the forward portion of the frame 6, as at *y*, is a lever 21, one arm (*c*) of which is turned upwardly adjacent to the trip lever 11 and is provided with a set screw 22 therein against which the plain arm *b*<sup>2</sup> of said last-named lever 11 is adapted to act as below explained. The other arm (*c'*) of the lever 21 is extended horizontally, or substantially so, and is provided with a horizontal perforated guide-head 23 thereon for the passage of the wire *w*. The head is shown as a channeled block with a cap plate affixed thereto. The lever 21 is maintained in the normal position by means of a spring *c*<sup>2</sup> which acts against the under side of the arm *c*, as seen in Figs. 1, 3, and 4.

Fitted to a suitable guide-way in the forward part of the frame-work, is a transverse rod 24 on the inner end of which is a pin or former 25 around which is bent or adapted to be bent the wire that projects through the guide-head. This rod is reciprocative longitudinally for the purpose of projecting or retracting the pin in respect to the wire. In this instance the outer end of the rod is pivoted to a vertical lever 26 fulcrumed to a bracket on the frame. The upper end of this lever carries an anti-friction roller 27 which is held yieldingly in contact with a depending cam-piece on the plunger by means of a spring 28. This cam-piece is simply a vertical plate affixed to a bracket on the lower end of the plunger and provided with a projection *d*. When the plunger is depressed the roller bears against the plain portion *d'* of the plate to maintain the stud inwardly projected, but during the upward stroke of the plunger the projection on the plate impinges against the roller and forces it outwardly, thereby retracting the rod and therewith the former pin or stud.

The forward end of the shaft 8 is provided with an appropriate collar or bushing 29 to which is eccentrically pivoted, as at *z*, a vertical lever 30, the upper or longer arm of which is equipped with a guide-block 31 fitted to a suitable way 32 in a rearward part of the frame-work, while the shorter arm is provided with a stud 33 that lies below and forward of the former pin 25 when the plunger is depressed. During the upward stroke of the plunger, the lower arm of the lever 30 in its movement travels in an arc of a circle, to the end that the stud thereon will take against the superimposed end of the wire and bend said end over upon the former pin, as illustrated in Fig. 4, and during the succeeding downward stroke of the plunger the said pin

will resume its first-described position. Thus the lever 30 has imparted to it a longitudinal rocking motion, that is to say, the lever is moved longitudinally and rocked during its movement.

As hereinbefore mentioned one arm of the trip-lever, during its partial rotation, by the upwardly moving bell-crank lever, strikes against the set-screw on the opposed arm of the guide bearing lever, thereby forcing said arm outwardly and raising the other arm thereof, in consequence of which the upper corner of the guide-block takes against the wire adjacent to the former and presses the contiguous portion of the wire upward toward the turned-over portion. Hence the wire is not only looped but an eye is formed thereon. By properly adjusting the set-screw, the curvature of this eye may be increased or diminished at will. If it be desired to make a mere loop the screw is adjusted below the path of the trip-lever. Located at a suitable point in advance of the former is a fixed cutter 34 with which is adapted to co-act a reciprocative cutter 35 depending from the plunger. When the loop or eye has been formed and the former pin retracted therefrom, the wire is fed or drawn forward upon the fixed cutter. In the next stroke of the plunger the loop or eye will be severed from the wire, and, at the same time, the projecting end of the wire will be bent over upon the former pin, as in the previous operation, and so on continuously.

Where the machine is used in the formation of eyes for the tips of umbrella ribs, rods, &c., the usual male and female dies may, if desired, be arranged in juxtaposition to the forming devices, to the end that the eyes as they are successively formed may be applied to the ribs in the ordinary manner, *i. e.*, by the co-operation of the two dies. See Fig. 7.

I claim as my invention—

1. In a machine for making looped wire devices, the combination, with a lever provided with a stud or projection on one arm thereof, and longitudinal guide devices on the other arm thereof, of means for imparting a longitudinal rocking motion to said lever, a reciprocative former pin adjacent to the stud or projection on said lever, a wire guide adjacent to said pin, and means for reciprocating said pin, substantially as described.

2. In a machine for making looped wire devices, the combination, with a lever provided with a stud or projection on one arm thereof, and longitudinal guide devices on the other arm thereof, of means for imparting a longitudinal rocking motion to said lever, a reciprocative former pin adjacent to the stud or projection on said lever, an oscillatory wire-guide adjacent to said pin, means for actuating said guide, and means for retracting the pin, substantially as described.

3. In a machine for making looped wire devices, the combination, with a former pin, means to bend the wire thereon, a normally-

depressed wire-guide adjacent to said pin, and means for raising said guide at predetermined periods, substantially as described.

4. In a machine for making looped wire devices, the combination, with a reciprocative former-pin, means for reciprocating the same, and means to bend the wire over upon said pin, of an oscillatory wire-guide adjacent to said pin, and means for actuating said guide, substantially as described.

5. In a machine for making looped wire devices, the combination, with a reciprocative former-pin, means to reciprocate the same, and means to bend the wire over upon said pin, of a rocking lever carrying a wire-guide on one arm thereof, and means for actuating the other arm of the lever, substantially as described.

6. In a machine for making looped wire devices, the combination, with two shafts and their co-acting gears, of a reciprocative former pin, a bending device connected with one of said shafts and adapted to bend the wire on said pin, a trip lever on the other shaft, means for engaging and releasing said lever at predetermined intervals, and a rocking lever, one arm of which extends in the path of said trip lever and the other arm of which bears a wire-guide in proximity to the former-pin, substantially as described.

7. In a machine for making looped wire devices, the combination, with two shafts and their co-acting gears, of a reciprocative former-pin, a bending device connected with one of said shafts and adapted to bend the wire on said pin, a trip-lever on the other shaft, means for engaging and releasing said lever at predetermined intervals, and a rocking lever, one arm of which is provided with an adjustable abutment in the path of said trip-lever, and the other arm of which bears a wire-guide in proximity to the former-pin, substantially as described.

8. In a machine for making looped wire devices, the combination, with two shafts and their co-acting gears, of a former-pin, a wire-bending device connected with one of said shafts, a trip on the other shaft, and means for engaging and releasing said trip at predetermined intervals, a dash-pot, its plunger, and a rod connecting said plunger with one of said gears, together with the retracting spring, substantially as described.

9. In a machine for making looped wire devices, the combination, with the supporting frame and the reciprocative plunger therein, of two shafts, their co-acting gears, a former-pin, a bending device connected with one of said shafts, a trip on the other shaft, a bell-crank lever mounted on said plunger, one arm of said lever being constructed to engage said trip, and a stop or abutment on the supporting frame in the path of the other arm of the crank-lever, substantially as described.

10. In a machine for making looped wire devices, the combination, with the supporting frame and the reciprocative plunger therein, of two shafts, their co-acting gears, a former-pin, a bending device connected with one of said shafts, a trip-lever on the other shaft, a bell-crank lever mounted on the said plunger, one arm being constructed to engage said trip-lever, a stop or abutment on the supporting frame in the path of the other arm of the crank-lever, a wire-guide adjacent to the former-pin, and a rocking-lever upon one arm of which said guide is supported, the other arm thereof being extended in the path of the trip-lever, substantially as described.

11. In a machine for making looped wire devices, the combination, with the supporting frame and the reciprocative plunger therein, of a reciprocative former-pin, a lever with which said pin is connected, a depending cam plate on the plunger adapted to co-act with said lever to retract the pin, the spring acting upon said lever, the wire-bending device adjacent to said pin, and means for operating said device, substantially as described.

12. The combination, with the supporting frame and the plunger, of the reciprocative former pin, connections between the same and the plunger, the shafts, their co-acting gears, the bending lever connected with one of said shafts, the trip-lever devices for actuating the other shaft, the retracting spring connected with one of said gears, the oscillatory wire-guide, and the cutters, substantially as described.

In testimony whereof I have hereunto affixed my signature in the presence of two subscribing witnesses.

CHARLES F. WURSTER.

Witnesses:

JESSE B. HELLER,  
JOHN R. NOLAN.