

(19) World Intellectual Property Organization
International Bureau



(43) International Publication Date
11 August 2005 (11.08.2005)

PCT

(10) International Publication Number
WO 2005/073745 A1

(51) International Patent Classification⁷: G01R 33/28, A61M 25/00, 25/01

55311 (US). ZHONG, Sheng-Ping [CN/US]; 21 Charina Road, Northborough, MA 01532 (US).

(21) International Application Number: PCT/US2005/000315

(74) Agent: GAGEL, John, J.; Fish & Richardson P.C., 225 Franklin Street, Boston, MA 02110-2804 (US).

(22) International Filing Date: 6 January 2005 (06.01.2005)

(81) Designated States (unless otherwise indicated, for every kind of national protection available): AE, AG, AL, AM, AT, AU, AZ, BA, BB, BG, BR, BW, BY, BZ, CA, CH, CN, CO, CR, CU, CZ, DE, DK, DM, DZ, EC, EE, EG, ES, FI, GB, GD, GE, GH, GM, HR, HU, ID, IL, IN, IS, JP, KE, KG, KP, KR, KZ, LC, LK, LR, LS, LT, LU, LV, MA, MD, MG, MK, MN, MW, MX, MZ, NA, NI, NO, NZ, OM, PG, PH, PL, PT, RO, RU, SC, SD, SE, SG, SK, SL, SY, TJ, TM, TN, TR, TT, TZ, UA, UG, US, UZ, VC, VN, YU, ZA, ZM, ZW.

(25) Filing Language: English

(26) Publication Language: English

(30) Priority Data: 10/763,690 23 January 2004 (23.01.2004) US

(71) Applicant (for all designated States except US): BOSTON SCIENTIFIC SCIMED, INC. [US/US]; One Scimed Place, Maple Grove, MN 55311-1566 (US).

(72) Inventors; and
(75) Inventors/Applicants (for US only): SMITH, Scott, R. [US/US]; 6950 County Road 10, Chaska, MN 55318 (US). WALAK, Steven, E. [US/US]; 5 Digren Road, Natick, MA 01760 (US). WANG, Lixiao [US/US]; 1205 Oakview Road, Long Lake, MN 55356 (US). WEBER, Jan [NL/US]; 18112 89th Place North, Maple Grove, MN

(84) Designated States (unless otherwise indicated, for every kind of regional protection available): ARIPO (BW, GH, GM, KE, LS, MW, MZ, NA, SD, SL, SZ, TZ, UG, ZM, ZW), Eurasian (AM, AZ, BY, KG, KZ, MD, RU, TJ, TM), European (AT, BE, BG, CH, CY, CZ, DE, DK, EE, ES, FI, FR, GB, GR, HU, IE, IS, IT, LT, LU, MC, NL, PL, PT, RO, SE, SI, SK, TR), OAPI (BF, BJ, CF, CG, CI, CM, GA, GN, GQ, GW, ML, MR, NE, SN, TD, TG).

[Continued on next page]

(54) Title: MEDICAL DEVICES VISIBLE BY MAGNETIC RESONANCE IMAGING

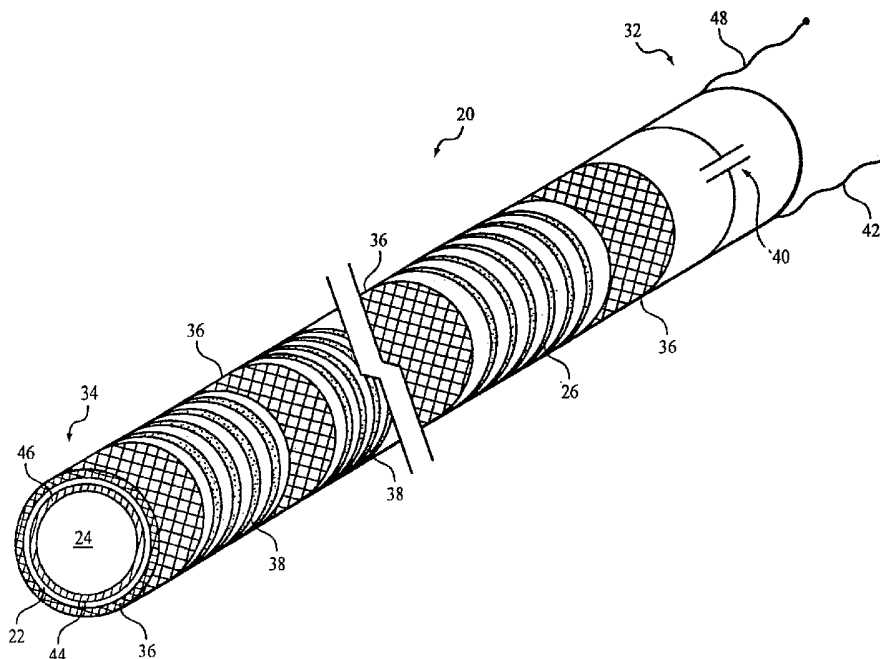

(57) Abstract: Medical devices that are visible by magnetic resonance imaging (MRI), and optionally, other imaging techniques, are described. In some embodiments, a medical device adapted for insertion into the body includes an elongated shaft (22) and an electrically conductive path (26) extending spirally about a portion of the shaft. The conductive path is capable of being connected to a current source. The medical device can further include one or more contrast agents (such as MRI contrast agents, radiopaque materials, and/or ultrasound visible materials), which can be arranged in a predetermined manner.

WO 2005/073745 A1



Published:

- *with international search report*
- *before the expiration of the time limit for amending the claims and to be republished in the event of receipt of amendments*

For two-letter codes and other abbreviations, refer to the "Guidance Notes on Codes and Abbreviations" appearing at the beginning of each regular issue of the PCT Gazette.

MEDICAL DEVICES VISIBLE BY MAGNETIC RESONANCE IMAGING

TECHNICAL FIELD

The invention relates to medical devices, such as catheters and guidewires, that are
- 5 visible by magnetic resonance imaging (MRI).

BACKGROUND

Certain medical devices are inserted and/or implanted into the body of a patient to
perform a medical procedure. Examples of these devices include catheters, guidewires,
10 medical balloons, stents, and stent-grafts. When a device is advanced through the body, its
progress is preferably monitored, e.g., tracked, so that the device can be delivered properly to
a target site. After the device is delivered to the target site, the device is preferably monitored
to determine whether it has been placed properly and/or is functioning properly.

One method of monitoring a medical device is magnetic resonance imaging (MRI).
15 MRI is a non-invasive technique that uses a magnetic field and radio waves to image the
body. In MRI procedures, the patient is exposed to a magnetic field, which interacts with
certain atoms, e.g., hydrogen atoms, in the patient's body. Incident radio waves are then
directed at the patient. The incident radio waves interact with atoms in the patient's body,
and produce characteristic return radio waves. The return radio waves are detected by a
20 scanner and processed by a computer to generate an image of the body, thereby providing
information about the placement and/or the functioning of the medical device.

SUMMARY

Medical devices adapted to be advanced through a patient and that are visible by
25 magnetic resonance imaging (MRI) are described. In some embodiments, the devices
include one or more features, such as contrast agent(s), that enhance the visibility of the
devices under other monitoring or tracking methods, such as X-ray fluoroscopy and/or
ultrasound spectroscopy. The visibility enhancing feature(s) can form a characteristic pattern
that can be easily detected, e.g., by a pattern recognition system. The feature(s) allow the
30 devices to be monitored in real time, e.g., during an interventional or intravascular procedure,
to provide an indication that the devices are functioning properly.

In one aspect, the invention features a medical device having a conductive path, such as a spiral or a coil, capable of carrying a current. During use, a current is sent through the conductive path, which creates a weak local magnetic field that influences the gyromagnetic behavior of nearby atoms and their radiofrequency (RF) signals. The RF signal can be detected and processed to provide an indication of the position of the medical device. 5 Alternatively or in addition, an alternating current is sent through the conductive path to create an RF signal that is directly receivable by an MRI system. Incident radio waves from the MRI system can also induce an RF signal from the conductive path, and the induced RF signal can be detected and processed to provide an indication of the position of the medical 10 device. In some cases, the conductive path is defined by a conductive polymer or a thin conductive coating containing carbon. The medical device can further include one or more contrast agents arranged in a characteristic pattern to enhance the visibility of the device under different monitoring methods.

In another aspect, the invention features a medical device adapted for insertion into the body including an elongated shaft, and an electrically conductive path extending spirally 15 about a portion of the shaft, wherein the conductive path is capable of being connected to a current source.

Embodiments may include one or more of the following features. The shaft includes an inner surface defining a lumen. The conductive path is defined by a conductive polymer 20 (e.g., polyaniline and/or polypyrrole), conductive carbon (e.g., amorphous carbon and/or carbon nanotubes), and/or a metal (e.g., gold, platinum, tungsten, tantalum, silver, titanium, and/or copper). The conductive path has a thickness of less than about ten μm . A portion of the electrically conductive path is defined by a metal wire. The conductive path extends along an inner surface of the shaft. The electrically conductive path extends spirally in a first 25 direction along the shaft, and extends spirally in a second direction counter to the first direction along the shaft. The shaft includes an electrically insulating layer (e.g., a polymer) between portions of the conductive path. The conductive path defines a series of coiled portions spaced from each other. The conductive path defines a band between the coiled portions.

30 The medical device can further include a capacitor electrically connected to the conductive path, the conductive path and the capacitor forming an LC circuit. The capacitor

can be a fractal capacitor. The LC circuit can have a resonance frequency tuned to a MRI frequency of the body tissue. The LC circuit can have a resonance frequency tuned to a Larmor frequency of hydrogen.

The medical device can further include a MRI contrast agent. The MRI contrast agent can include a T_1 relaxation agent, such as one including gadolinium. The MRI contrast agent can include a material capable of generating a magnetic susceptibility artifact, such as a superparamagnetic material, a paramagnetic material, a ferromagnetic material, and/or a diamagnetic material. The MRI contrast agent can be encapsulated in a lumen, a hollow fiber, a microporous material, a mesoporous material, a nanoporous material, a channel, and/or a cavity. The MRI contrast agent can be embedded in a material of the device. The device can further include a coating (e.g., a polyurethane, a polyacrylic acid, and/or an acrylamide) that includes the MRI contrast agent. The device can further include an air-filled cavity. The device can further include a plurality of contrast agents (e.g., a T_1 relaxation agent, a material capable of generating a magnetic susceptibility artifact, a radiopaque material, and/or an ultrasound visible portion) arranged in a regular pattern.

The device can be a catheter, such as a guide catheter, a balloon catheter, a tumor ablation catheter, an aneurysm catheter, a urology catheter, or a perfusion catheter.

The medical device can be a polymeric guide wire. The guide wire can include polyethylene, for example, one having a Young's modulus of greater than about 10 GPa and/or a tensile strength of greater than about 0.5 GPa. The device can be a sheath introducer.

In another aspect, the invention features a medical device adapted for insertion into body tissue. The device includes a polymeric shaft having an inner surface defining a lumen; and an electrically conductive path extending spirally about the polymeric shaft and on the inner surface of the polymeric shaft. A portion of the conductive path is defined by a first conductive coating, wherein the conductive path is capable of being connected to a current source. The conductive path can cover substantially the entire inner surface of the polymeric shaft.

In yet another aspect, the invention features a medical device adapted for insertion into the body including a polymeric shaft having an inner surface defining a lumen, an electrically conductive path extending spirally about the polymeric shaft and on the inner

surface of the shaft, wherein a first portion of the conductive path is defined by a conductive coating, and a second portion of the conductive path is defined by a metal wire. The second portion of the conductive path can extend on the inner surface of the shaft.

In another aspect, the invention features a medical device adapted for insertion into the body including a polymeric shaft having an inner surface defining a lumen; an electrically conductive path, a first portion of the path extending spirally in a first direction along the shaft, and a second portion of the path extending spirally in a second direction counter to the first direction along the shaft, the conductive path being defined at least in part by a conductive coating, and an insulating layer between the first and second portions of the conductive path.

In another aspect, the invention features a medical device including a first plurality of portions having a first contrast agent, and a second plurality of portions comprising a second contrast agent different than the first contrast agent, wherein the first and second pluralities of portions are arranged in a regular pattern.

Embodiments may include one or more of the following features. The first contrast agent can be a T_1 relaxation agent or a material capable of generating a magnetic susceptibility artifact. Portions of the first plurality can alternate with the portions of the second plurality. The device can further include a third portion capable of generating a signal void. The device can further include a radiopaque portion or a portion that is visible by ultrasound spectroscopy.

In another aspect, the invention features a medical device including a first plurality of portions having a first contrast agent, and a second plurality of portions capable of generating a signal void, wherein the first and second pluralities of portions are arranged in a regular pattern. The first contrast agent can include a T_1 relaxation agent or a material capable of generating a magnetic susceptibility artifact. Portions of the first plurality can alternate with the portions of the second plurality.

The details of embodiments of the invention are set forth in the accompanying drawings and the description below. Other aspects, features, and advantages of the invention will be apparent from the description and drawings, and from the claims.

DESCRIPTION OF DRAWINGS

Fig. 1 is an illustration of a medical device.

Fig. 2 is a cross-sectional view of the device of Fig. 1, taken along the distal end of the device.

5 Fig. 3 is a cross-sectional view of a medical device.

Fig. 4 is a cross-sectional view of a medical device.

Fig. 5 is an illustration of a medical device.

Fig. 6 is an illustration of a medical device.

Fig. 7 is an illustration of a medical device.

10 Fig. 8 is an illustration of a medical device.

Fig. 9 is an illustration of a balloon catheter.

Fig. 10 is an illustration of a medical device.

Fig. 11 is an illustration of a medical device.

DETAILED DESCRIPTION

15 Referring to Fig. 1, a medical device 20 (as shown, a tubing or a catheter) includes an elongated shaft 22 and a conductive path 26 formed on the shaft. Referring as well to Fig. 2, shaft 22 has an exterior surface 28 and an interior surface 30 that defines a lumen 24.

20 Conductive path 26 is disposed on exterior surface 28 and interior surface 30, extending from a proximal end 32 to a distal end 34 of device 20. As shown, conductive path 26 includes a plurality of alternating solid portions or bands 36 and coil portions 38 extending on exterior surface 28 and along the length of shaft 22. Near proximal end 32, conductive path 26 includes a capacitor 40 and terminates with an electrical lead 42. At distal end 34, conductive path 26 extends across a conductive bridge 44 to interior surface 30, where the
25 conductive path includes a solid conductive portion 46 that serves as a return path for flowing current (described below). Solid portion 46 extends proximally and terminates with an electrical lead 48. Leads 42 and 48 are capable of being connected to a current source (not shown).

30 As described below, during use, when leads 42 and 48 are connected to a current source and current is passed through coil portions 38 (which acts as an inductor) and capacitor 40 (which together to the inductor forms an LC circuit), the visibility of medical

device 20 can be actively enhanced for magnetic resonance imaging (MRI). For example, in an MRI-processed image, coil portions 38 can appear as a characteristic pattern, such as a series of bright portions, that can be easily detected and distinguished by eye or by a detection system from surrounding body tissue.

5 Still referring to Fig. 1, shaft 22 can be formed of one or more materials, such as non-magnetic materials, that do not interfere with the MRI visibility of device 20. The material can be visibly transparent or opaque. Examples of materials include polymers, such as, for example, polypropylene, polyethylene (such as high density polyethylene), polysulfonate, polyamide (e.g., Nylon), polyethyleneterephthalate (PET), polytetrafluoroethylene (PTFE),
10 polyacetonitrile, polymer-amorphous carbon composites, and polymer-carbon nanotube composites. The polymers can be extruded to form a flexible shaft that can navigate a tortuous path. Other polymers that can be used, including additives such as compatibilizers, and methods of making a tube or a catheter (e.g., a multilayer tube or catheter) are described in commonly-assigned U.S.S.N. 10/645,014, entitled "Medical Devices" and filed on August
15 21, 2003. Examples of non-polymer materials include ceramics, glass, or non-ferromagnetic metals, such as aluminum and titanium.

In some embodiments, conductive path 26 includes a thin coating of one or more conductive materials. Examples of materials include conductive polymers, such as polyaniline, polypyrrole, or poly(ethylene-dioxythiophene) (PEDT), and conductive carbon
20 (e.g., graphite). Syntheses of conductive polymers are described in the literature. Conductive polymers are also available commercially, for example, polyaniline from Panipol (Porvoo, Finland), polyaniline- and polypyrrole-coated carbon powders as well as highly soluble emeraldine base (EB) from Eeonyx Corp., polypyrrole dispersions having different core materials from DSM, and PEDT from H.C. Starck. Other materials include metals
25 having low magnetic susceptibility, such as copper, silver, gold, platinum, tungsten, tantalum, titanium, or alloys of these materials. The material can be radiopaque, e.g., visible by X-ray fluoroscopy. Examples of radiopaque materials include tantalum, tungsten, gold, platinum, palladium, or their alloys. The coating of material(s) can have a thickness of about ten
nanometers to about 20 micrometers, although larger thicknesses can be formed. By forming
30 the coating thin, the conductive path can be formed to enhance the MRI visibility of device 20, while not compromising (e.g., degrading) the mechanical properties of the device. In

certain cases, such as balloon catheters, having a relatively thick coating can increase the rigidity of the catheter. As a result, the catheter may not be able to travel well through a narrow and tortuous path.

Conductive path 26 can be formed using any of a variety of techniques. For example, certain conductive polymers can be dissolved in an organic solvent or dispersed in aqueous or non-aqueous media, and then applied (e.g., casted, sprayed or painted) to form a pre-selected pattern. Other techniques include plating, dipping, spraying, sputtering, plasma deposition, chemical vapor deposition, physical vapor deposition, or pulse laser deposition (PLD). Selected patterns of conductive path 26 can be formed, for example, by covering selected portions of shaft 22 with a mask (such as an adhesive tape or a dissolve material (e.g., polysaccharide, gelatin, or polyvinyl alcohol (PVA))) prior to forming the conductive path, and subsequently removing the mask after the path is formed. Another technique is to form a complete, uniform coating and subsequently remove selected areas to form conductive path 26, e.g., using excimer laser ablation. Another technique is to use conductive polymeric fibers or textile to form conductive path 26.

Other configurations of conductive path 26 can be formed. Referring to Fig. 3, a conductive layer 52 (e.g., a conductive polymer or conductive carbon) can be applied to shaft 22 to serve as a current return path. Subsequently, an insulating layer 54 can be applied to conductive layer 52. Insulating layer 54 can include a polymer (e.g., a heat shrink polymer such as a polyolefin, polytetrafluoroethylene (PTFE), polyamide (e.g., Nylon), polyvinyl chloride (PVC), or polyterephthalate (PET)) or a ceramic. Conductive path 26 can be completed by forming bands 36 and coil portions 38 on insulating layer 54. In some cases, bands 36 and/or coil portions 38 can be covered, e.g., with a protective polymer coating, to prevent damage to conductive path 26. Conductive layer 52 or solid portion 46 can cover substantially all of their respective adjacent surfaces or only a portion thereof, e.g., as a stripe extending to proximal end 32. In other embodiments, referring to Fig. 4, solid portion 46 can be replaced with a conductive wire 50 (e.g., a copper wire) that extends along the length of shaft 22 (e.g., from distal end 34 to proximal end 32 to lead 48). Wire 50 can be embedded in shaft 22 (as shown) or be disposed on (e.g., glued to) interior surface 30. Wire 50, or a stripe of solid portion 46 or conductive layer 52, can extend linearly or helically (e.g., counter to the direction of coil portions 38) to proximal end 32.

Other configurations of bands 36 and/or coil portions 38 are possible. In some embodiments, a conductive path does not include any bands. Referring to Fig. 5, one coil portion 38 can extend the entire length of a device or at a selected portion of the device. Multiple, spaced coil portions 38 can extend the entire length of a device or at selected portions of the device. The length (L) of coil portions 38 and/or bands 36 can be same or different (as shown in Fig. 6). The spacing between coil portions 38 and/or bands 36 can be the same or different. Different configurations of bands and/or coil portions can affect the mechanical properties (such as flexibility and resistance to kinking) of the medical device.

To form a complete circuit, bridge 44, capacitor 40, and leads 42 and 48 are connected to conductive path 26. Bridge 44 can be formed using an electrically conducting epoxy or by applying one or more of the electrically conducting materials described above using any of the above techniques. An example of capacitor 40 is one having a capacitance of about 10.2 pF for a circuit to resonate at 64 mHz with an inductance, L, of about 6×10^{-7} Henry. In some embodiments, to reduce any adverse effect on the mechanical performance of device 10, capacitor 40 is a fractal capacitor (e.g., as described in Samavati et al., "Fractal Capacitors" IEEE Journal of Solid-State Circuits, Vol. 33, No. 12, December 1998, p. 2035-2041). Capacitor 40 can be a component of the current source. Capacitor 40, such as those available from Fractus, S.A. (Barcelona, Spain), can be attached (e.g., glued) to device 20 near proximal end 32 and electrically connected to conductive path 26. The LC circuit can be a serial LC circuit or a parallel LC circuit. In some cases, a resistor is included in the LC circuit to lower the Q-value and broaden the magnetic resonance signal generated by the conductive path 105. Leads 42 and 48 can be connected to conductive path 26 at proximal end 32 using, for example, a conductive epoxy or solder.

In operation, device 20 is inserted into a subject (e.g., a human patient), and the subject is placed into an MRI system. The MRI system is capable of imaging the subject (e.g., body tissue) according to conventional methods, as described, for example, in U.S. Patent No. 6,280,385. Additionally, during operation, a current is passed through conductive path 26, for example, sequentially or simultaneously with the pulsing of the incident radio waves. As current is passed through the circuit, in particular, through coil portions 38, the current induces a local magnetic field in the coil portions. The magnetic field generates a magnetic resonance signal (e.g., equal to the resonance frequency of the applied field from

the MRI system) that can be detected processed by the MRI system. The MRI system is capable of processing the signals from device 20 and from the subject, superimposing the signals, and generating an image of both the device and the subject, thereby providing a real time indication of the position of device 20.

5 Other variations can be used. In some embodiments, the amount of current applied can be varied to enhance the visibility of device 20 according to the MRI system or sequence being used.

The LC circuit can also be tuned to change the resonance frequency of the loop circuit and facilitate detection of device 20 over a range of magnetic field strengths (e.g., 0.5
10 T, 1.5 T, and 3.0 T). For example, the resonance frequency can be changed by adding or removing one or more additional capacitors connected between leads 42 and 48, in parallel with capacitor 40. The additional capacitor(s) can be a part of one or more modular units adapted to engage (e.g., click and lock) with the proximal end of the catheter.

In other embodiments, the resonance frequency can be changed by short circuiting
15 one or more coil portions 38 (e.g., with a conductive strip). A coil portion can be short circuited by contacting (e.g., sliding) a tube or C-clamp having a conductive inner surface over the coil portion. As the tube or C-clamp is slid over the coil portion, portions of (or the entire) coil portion is short circuited, which changes the inductance of the coil portion and the overall LC resonance frequency. The short circuiting can occur incrementally as a function
20 of the number of windings in a coil portion, e.g., in ten discrete steps for a coil portion having ten windings. In other embodiments, the tube or C-clamp includes an inner surface having a conductive coil of different pitch than the windings of the underlying coil portion. Sliding the tube or C-clamp over a coil portion short circuits only parts of the coil portion, thereby allowing the inductance of the coil portion to be changed in finer increments.

25 The capacitor(s) described herein can be microelectromechanical systems (MEMS) tunable capacitor(s). MEMS tunable capacitors are described, for example, in Zou et al., *Development of a Wide Tuning Range MEMS Tunable Capacitor for Wireless Communications Systems*, Technical Digest - International Electron Devices Meeting 2000, p. 403-406. The MEMS tunable capacitor allows the capacitance value of the capacitor to be
30 changed automatically. For example, the information from an MRI image can be used by a processor to directly update the capacitor continuously to enhance the resonance frequency of

the system. The MRI system can detune or tune the LC circuit to enhance the visibility of the catheter by enhancing the contrast in real time.

Still in other embodiments, a direct current is passed through conductive path 26 that induces a magnetic field, which disturbs the local spin behavior to provide a detectable
5 signal.

Alternatively or in addition, the radio wave pulses from the MRI system can cause the LC circuit to resonate at the magnetic resonance frequency, thereby providing a passive (i.e., no applied current) method of imaging device 20, as described in Melzer, et al., U.S. Patent No. 6,280,385. Briefly, when incident radio wave pulses strike coil portions 38, a magnetic
10 field is induced within the coil portions. The induced magnetic field in turn generates an eddy current that flows to capacitor 40, where the current is temporarily stored. When the incident radio wave pulses are paused, the current stored in capacitor 40 flow to coil portions 38, where the current now produces a local magnetic field with a magnetic resonance signal (e.g., at the magnetic resonance frequency of the MRI system). The MRI system is capable
15 of detecting the signal from the LC circuit, processing the data to provide an image of device 20, and superimposing the images of the device and the subject to produce an image of the device in the subject on a visual display. As a result, real time imaging of device 20 can be performed.

20

Other Embodiments

In certain embodiments, such as when a direct current is passed through conductive path 26, device 20 does not include a capacitor.

In other embodiments, device 20 can include one or more agents that can further enhance MRI visibility, and/or enhance fluoroscopic and/or ultrasound visibility of the
25 device. The agent, sometimes called a contrast agent, can be in the form of, e.g., a neat liquid, particles, a solution, a hydrogel, or an emulsion. The agent can have an MRI response that is different than the MRI response of the medical device in which the contrast agent is used, and/or the MRI response of the bodily tissue or fluid near the contrast agent during use. The MRI response is the response to a magnetic field or radio waves used during MRI. In
30 some embodiments, the contrast agent includes one or more materials having a T_1 relaxation time that is different than that of the medical device and/or tissue. For example, the contrast

agent can include a material that appears bright in an MRI image, such as a solution having a T_1 (longitudinal) relaxation time shortening agent and a proton-containing fluid, such as water or glycerin. Examples of T_1 relaxation time shortening agents include a paramagnetic metal salt or a paramagnetic metal chelate compound, such as heavy metal complexes, e.g., gadolinium diethylenetriaminepentaacetic acid (e.g., a 1% Gd-DTPA aqueous solution),
5 GdDTPA-BMA, and GdHP-D03A (e.g., available from Schering, Nycomed and Bracco under the trade marks MAGNEVIST®, OMNISCAN®, and PROHANCE®).

Alternatively or in addition, the contrast agent can include one or more materials that produce a magnetic susceptibility artifact (i.e., an artifact marker that appears dark in an MRI
10 image). The material can have a T_2 relaxation time that is different than that of the medical device and/or tissue. For example, the contrast agent can include a carrier or a fluid having ferromagnetic, ferrimagnetic, or superparamagnetic nanoparticles, such as iron oxide, dysprosium oxide, and/or gadolinium oxide. The particles can be surface modified, e.g., made hydrophilic, to suspend the particles in the fluid and reduce the occurrence of
15 precipitation and/or coagulation. Examples of particles and methods of modifying the particles are described in U.S. Patent Nos. 6,123,920 and 6,423,296, hereby incorporated by reference. A magnetic susceptibility artifact can also be introduced into the MRI image by including an air-filled cavity in the medical device, e.g., in shaft 22.

The contrast agent can be embedded into shaft 22. For example, the contrast agent
20 can be encapsulated in hollow members, such as hollow fibers, and dispersed in the shaft as described in commonly-assigned U.S.S.N. 10/390,202, filed March 17, 2003. The contrast agent can be contained in a cavity or a lumen defined by the medical device, and/or by supported on a porous material, such as a ceramic material (e.g., aluminum oxide, titanium oxide, or a zeolite). Solid contrast agents can be blended into a structural material of device
25 20 (e.g., a polymer of shaft 22) and extruded to form the device. The contrast agent can be applied directly to the surface of the device, e.g., as a neat material or in the presence of solvent. In embodiments, the contrast agent can be mixed with an adhesive (such as a polyurethane adhesive) and applied to the surface as a coating, e.g., from about 50 to about 300 microns thick.

30 Alternatively or in addition, the MRI contrast agent can be incorporated into a coating composition and coated onto a surface of the medical device. The coating can be on an

interior surface and/or on the exterior surface of a medical device. Forming the coating on an interior surface can reduce loss of the contrast agent by fluid exchange (e.g., with bodily fluid), thereby enhancing the effective lifetime of the contrast agent. The contrast agent can be incorporated into a coating using methods such as compounding or blending.

5 The coating composition can include a lubricous, hydrophilic and/or hydrogel material used to improve biocompatibility and to aid insertion of the device through the body. Hydrophilic and hydrogel polymers include, e.g., polyethylene oxide, polypropylene oxide, polyvinyl-pyrrolidone, polycarboxylic acid, cellulosic polymers, gelatin, maleic anhydride polymers, polysaccharides, polyvinyl alcohol, polyacrylic acid, hyaluronic acid,
10 collagen, and poly(2-hydroxyethyl methacrylate) (polyHEMA). For example, Gd-DTPA can be dissolved in water and mixed with a 1% polyacrylic acid/polyacrylamide hydrogel solution. The mixture (a hydrogel/Gd-DTPA complex) can be attached to a device by covalent bonding. Such methods are described in U.S.S.N. 09/995,528, filed November 27, 2001.

15 Methods for applying coatings to medical devices include, for example, dip coating and spraying. The surface of the medical device may be pre-treated in order to affix the coating to the surface of the device and/or enhance the hydrophilicity of plastic substrates prior to coating. Surface treatment techniques include, e.g., plasma activation, silanization, and treating the surface with a primer solution. Hydrophilic polymers can be integrated or
20 attached to the device by co-extruding with the shaft. The polymer of the shaft provides desirable mechanical properties while the hydrophilic polymer loaded with a contrast agent provides magnetic resonance contrast.

 Chemical and/or physical cross-linking of the coating may be used, depending on the type of coating, to prevent the coating from sloughing off or leaching from the surface of the
25 device during insertion and/or contact with the surrounding body fluids. Cross-linking can be achieved, for example, by using chemical or radiation-based (e.g., photochemical and electron beam) techniques.

 In some embodiments, the coating includes a releasable therapeutic agent, a drug, or a pharmaceutically active compound. Examples of agents include antithrombogenic agents,
30 antiproliferative agents, antioxidants, anti-inflammatory agents, anesthetic agents, anti-

coagulants, and antibiotics. Other agents, drugs, and compounds are described in U.S.S.N. 10/232,265, filed August 30, 2002.

The contrast agents can be formed on a medical device (such as shaft 22) in a predetermined sequence that can be easily recognized and distinguished from the surrounding body tissue under MRI, for example, using a pattern recognition system such as a pattern recognition software integrated in MRI software by the manufacturer. For example, referring to Fig. 7, a device 100 can include a series of bands 102 having a T₁ relaxation time shortening agent alternating with a series of bands 104 having a susceptibility artifact generating material, i.e., in an AB sequence that gives a characteristic alternating bright and dark MRI image. The device can have a portion with no contrast agent that would produce an absence of an MRI signal (i.e., a signal void) because of displaced bodily fluid. Sequences such as ABA, BAB, ABBA, or ABC are possible, where A can be a T₁ relaxation time shortening agent, B can be an artifact generating material or a signal void, and C is a marker or contrast agent different than A or B.

The MRI contrast agents can also be included in a medical device having the conductive path or LC circuit described above. Referring to FIG. 8, a device 106 includes an electrically conductive path 105 that extends spirally about a portion of the shaft 110. In addition, a plurality of marker bands 112 and 114 are arranged along the length of the catheter shaft 110. Marker bands 112 include a magnetic susceptibility artifact marker, and marker band 114 includes a T₁ enhancing material. Marker bands 112 and 114 can be arranged in a characteristic pattern as described above. By having both an active visibility enhancing system (i.e., conductive path 105) and a passive visibility enhancing system (marker bands 112 and 114), device 106 can be monitored using different visualization techniques, thereby enhancing the versatility of the device. In other embodiments, device 106 includes one or more signal void portions and/or one of the other types of contrast agents described below.

The devices described herein can include other types of contrast agents, such as those visible by X-ray fluoroscopy (i.e., a radiopaque material) and/or ultrasound spectroscopy. Examples of radiopaque materials include tantalum, tungsten, platinum, palladium, or gold. The radiopaque material can be placed inside an encapsulating member (for example, as described in U.S.S.N. 10/390,202) and/or compounded with the material of the medical

device. Alternatively or in addition, the radiopaque material, e.g., a band of radiopaque material, can be placed on a medical device at selected positions to make up a characteristic pattern. The ultrasound contrast agent can be any material that enhances visibility during ultrasound imaging. An ultrasound contrast agent can include a suspension having trapped
5 bubbles of sufficient size to deflect sound waves.

Any of the medical devices described above can include a coiled portion or an inductive element, an MRI contrast agent, a radiopaque material, and/or an ultrasound contrast agent, in any combination or arrangement (e.g., ABCD or ABCDE). A combination of inductive elements, MRI contrast agents, ultrasound contrast agents, and/or radiopaque
10 materials can offer the flexibility of visualizing a medical device under a variety of imaging conditions.

The tubing described above can be sized and shaped to form other devices. For example, referring to Fig. 9, device 20 can be attached to a medical balloon 200 to form into a balloon catheter (e.g., as described in commonly-assigned U.S.S.N. 10/263,225, filed
15 October 2, 2002, and entitled "Medical Balloon"; Anderson U.S. 6,120,364; Wang U.S. 5,714,110; and Noddin U.S. 4,963,313). Coil portions 38 can be used, for example, as markers that indicate the position of the balloon upon full inflation. Other examples of catheters into which the tubing can be formed include guide catheters (e.g., as described in U.S. 6,595,952), tumor ablation catheters, aneurysm catheters, urology catheters, and
20 perfusion catheters (e.g., as described in U.S. 6,503,224). The tubing can be formed into an introducer sheath or a restraining sheath for a stent delivery system, for example, as described in U.S. Patent No. 6,488,694. Methods of making tubing are described, for example, in U.S.S.N. 10/645,014, filed August 21, 2003.

In other embodiments, the conductive path and/or marker(s) (e.g., MRI visible
25 markers) described above can be incorporated into a guidewire, such as a polymeric guide wire. Some metal guide wires can absorb energy from the high power radiowave frequency energy used during MRI procedures. As a result, some metal guide wires can become hot, which can limit their use in MRI applications. Polymeric guide wires, in comparison, do not exhibit localized heating under MRI. Methods of making polymeric guide wires, including
30 examples of materials, are described in U.S. Patent No. 6,436,056, and U.S.S.N. 10/645,014, filed August 21, 2003.

In some embodiments, the guidewire includes a biocompatible polymer, such as polyethylene, e.g., high-density polyethylene (HDPE), which can form fibers having a good mechanical profile. The HDPE polymer can have an average molecular weight (M_w) of about 400,000 g/mol, and a molecular weight distribution (i.e., polydispersity) of about 3 to 7, for example, a polydispersity of about 5. The polymer can have a high molecular weight tail (e.g., 0-10% content of greater than about 1,000,000) to ensure the formation of extended chain crystals. A minimal amount ($\leq 0.1\%$) of low molecular weight (e.g., 4000 g/mol or less) fraction is preferred to prevent the premature onset of relaxation processes in the melt and to ensure force transfer during extrusion of the melt through a die. Low molecular weight fractions can be removed by extraction in an appropriate solvent (e.g., hexane) to increase the tensile module of the resulting fiber. Examples of HDPEs are commercially available from, e.g., BASSELL (BASF) Corporation under the trade designation LUPULEN 52ZHI; Chevron Phillips Corporation under the trade designation MARLEX TR-751; and Solvay Corporation under the trade designations RIGIDEX HM5420 XPH, AH 5493, and BH 5363.

A polymeric guide wire can be prepared, for example, by extrusion. The polymer can be extruded to form relatively stiff fibers having the requisite mechanical properties (e.g., Young's modulus (E) of greater than about 10 GPa and a tensile strength of greater than about 0.5 GPa). HDPE fibers can be prepared by solid-state extrusion of melt crystallized spherulitic polyethylene or by drawing solution crystallized gel films (e.g., performed by DSM (Heerlen, The Netherlands) as a process marketed as the Dyneema® Process). An alternative process involves melt deformation of HDPE under controlled conditions to obtain highly oriented fibers. The process involves chain extension of the high molecular weight fraction of HDPE having a linear macromolecular structure during flow just above the solidification temperature, followed by crystallization (e.g., of a high molecular weight fraction) and by co-crystallization (e.g., of a low molecular weight fraction) of the remaining material. The polymer can be extruded at a temperature close to the crystallization temperature (e.g., a self-blocking temperature, which can be indicated by an extrusion pressure rise, e.g., upward from about 3500 psi) and at a strain rate of about 10^3 s^{-1} to solidify the deformed macromolecules before relaxation occurs. In some cases, crystallization occurs from about T_g+30 to about T_m-10 (e.g., from about 140 to about 160°C). Such processing

conditions can create an elongated, interlocking morphology that displays exceptional mechanical properties (e.g., a Young's modulus (E) of between about 10-80 GPa and a tensile strength of about 1.2 GPa). The fibrils can make up about 5% of the extruded material and can have a diameter of between about 5-25 nm with an aspect ratio of about 200-600. The bulk material can be characterized as a lamellar overgrowth chain direction like in the fibrils. An example of an extrusion apparatus is a mini-extruder (Axxon BX 12, D=12.5 mm, L/D=26) with a suitably designed die (e.g., opening angle 45°, 1mm, l/d 25). The extrusion head can be equipped with a pressure transducer and a thermocouple to control pressure and temperature during extrusion. Additional information regarding HDPEs is described in Bashir, Z., et al., *J. Mat. Science*, 19 (1984), 3713; and Bashir, Z., et al., *J. Mat. Science*, 19 (1986), 3993. In certain embodiments, the extrusion head is equipped with one or more transducers or vibrators. Vibratory energy (e.g., ultrasonic vibrations) from the transducer(s) can allow the extrusion temperature to be lowered by reducing friction between the polymer melt and the surface of the extrusion head. Examples of vibrators include mechanical transducers (e.g., spring mass/moving coil systems) or solid state transducers such as those having piezoelectric elements, available, e.g., from STAPLA Ultrasonics Corp. (Wilmington, MA) and Blatek Inc. (State College, PA).

All of the features disclosed herein may be combined in any combination. For example, the HDPE polymer described above can be used to make any of the devices described above. Each feature disclosed may be replaced by an alternative feature serving the same, equivalent, or similar purpose. Thus, unless expressly stated otherwise, each feature disclosed is only an example of a generic series of equivalent or similar features.

The following examples are illustrative and not intended to be limiting.

Example 1

This example estimates how much field disturbance may be needed to make a visible marker.

For a coil portion like the coil portions shown in Fig. 1 with the axis of the coil portion along the central axis of the catheter, the magnetic field is created inside the coil portion and outside the coil portion along the direction of the axis of the coil. Since the

polymer of the catheter is creating a void, the visible material by MRI is the water inside of the catheter. The field inside of the coil with multiple windings can be calculated by:

$$B = I \cdot (N/L) \cdot \mu_0$$

where μ_0 is the permeability in a vacuum [$(\mu_0) = 12.566370614 \times 10^{-7}$ H/m (of N/A²)]; I is
 5 current in Ampere; and (N/L) is the number of windings per meter. Assuming that the
 artifact to be induced to be visible is similar to or greater than a typical fat-water chemical
 shift of 220 Hz at 1.5 T, then the field created inside the coil is 5.167×10^{-6} T relative to the
 field outside the coil. So, for a coil having a length of five mm and wherein the width of the
 individual conductive paths is 100 micrometer, with a spacing of 50 micrometers (i.e., 33
 10 windings over 5 mm gives a N/L of 6600), a current of 0.62 mA can be applied to obtain the
 targeted field.

Example 2

Alternatively or in addition to having the coil portion(s) as shown in Fig. 1 (which is
 15 generating a field in the direction of the catheter axis), a medical device can include portions
 capable of generating a field at an angle with the catheter axis. Figs. 10 and 11 show
 examples of coil portions capable of generating fields that can extend outside of the catheter
 tube and change the spin behavior, for example, of the water or blood, outside the catheter.

For a single coil as shown in Fig. 10, the field in the center of a single round loop is
 20 given by:

$$B_{z=0} = \mu_0 I / (2R)$$

where μ_0 is the permeability in a vacuum [$(\mu_0) = 12.566370614 \times 10^{-7}$ H/m (of N/A²)]; I is
 current in Ampere; and R is the radius of the loop.

The normalized B-field is given by the equation:

25

$$B_{rel} = \frac{B_z}{B_{z=0}} = \frac{b^3}{(b^2 + z^2)^{3/2}} = \left(\frac{b}{\sqrt{b^2 + z^2}} \right)^3$$

where b is the radius of the loop; z is the point of interest along the z-axis; and B_{rel} is the ratio
 of the magnetic field at the point interest to the maximum magnetic field.

To create a visibility of at least two voxels, or volume elements, in the MRI image, a magnetic field of 5.167×10^{-6} Tesla 0.8 mm outside the catheter tube is preferably created. For a tube having a diameter of 1.667 mm and in which the center of the winding lies at the center of the tube, the z value in the formula above is taken as $0.8 \text{ mm} + (1.667/2) \text{ mm} =$
5 1.653 mm. Therefore, $B_{\text{rel}} (b= 0.8335 \text{ mm}, z = 1.653 \text{ mm}) = 0.0913$. So, $B(z=0)$ is
($5.167 \times 10^{-6} / 0.09127$)Tesla = 5.66×10^{-5} T. Therefore, using $B_{z=0} = \mu_0 I / (2R)$ ($R = 0.8335 \times 10^{-3}$
10 m), $I = 75 \text{ mA}$. For the structure shown in Fig. 11, the magnetic field is twice as high, so
37.5 mA can be used.

All publications, applications, and patents referred to in this application are herein
10 incorporated by reference to the same extent as if each individual publication or patent was
specifically and individually indicated to be incorporated by reference in their entirety.

Other embodiments are within the claims.

WHAT IS CLAIMED IS:

1. A medical device adapted for insertion into the body, comprising:
an elongated shaft; and
an electrically conductive path extending spirally about a portion of the shaft, wherein the conductive path is capable of being connected to a current source.
2. The medical device of claim 1, wherein the shaft comprises an inner surface defining a lumen.
3. The medical device of claim 1, wherein the conductive path is defined by a material selected from the group consisting of a conductive polymer, conductive carbon, and a metal.
4. The medical device of claim 3, wherein the carbon comprises amorphous carbon or carbon nanotubes.
5. The medical device of claim 3, wherein the metal is selected from the group consisting of gold, platinum, tungsten, tantalum, silver, titanium, and copper.
6. The medical device of claim 3, wherein the conductive polymer is selected from the group consisting of polyaniline, polypyrrole, and poly(ethylene-dioxythiophene).
7. The medical device of claim 3, wherein the conductive path has a thickness of less than about ten μm .
8. The medical device of claim 1, wherein a portion of the electrically conductive path is defined by a metal wire.
9. The medical device of claim 1, wherein the conductive path extends along an inner surface of the shaft.

10. The medical device of claim 1, wherein the electrically conductive path extends spirally in a first direction along the shaft, and extends spirally in a second direction counter to the first direction along the shaft.

11. The medical device of claim 1, wherein the shaft comprises an electrically insulating layer between portions of the conductive path.

12. The medical device of claim 11, wherein the insulating layer comprises a polymer.

13. The medical device of claim 1, wherein the conductive path defines a series of coiled portions spaced from each other.

14. The medical device of claim 13, wherein the conductive path defines a band between the coiled portions.

15. The medical device of claim 1, further comprising a capacitor electrically connected to the conductive path, the conductive path and the capacitor forming an LC circuit.

16. The medical device of claim 15, wherein the capacitor is a fractal capacitor.

17. The medical device of claim 15, wherein the LC circuit has a resonance frequency tuned to a MRI frequency of the body tissue.

18. The medical device of claim 15, wherein the LC circuit has a resonance frequency tuned to a Larmor frequency of hydrogen.

19. The medical device of claim 1, further comprising a MRI contrast agent.

20. The medical device of claim 19, wherein the MRI contrast agent comprises a T₁ relaxation agent.
21. The medical device of claim 20, wherein the T₁ relaxation agent comprises gadolinium.
22. The medical device of claim 19, wherein the MRI contrast agent comprises a material capable of generating a magnetic susceptibility artifact.
23. The medical device of claim 22, wherein the material is selected from the group consisting of a superparamagnetic material, a paramagnetic material, a ferromagnetic material, and a diamagnetic material.
24. The medical device of claim 19, wherein the MRI contrast agent is encapsulated in a lumen, a hollow fiber, a microporous material, a channel, or a cavity.
25. The medical device of claim 19, wherein the MRI contrast agent is embedded in a material of the device.
26. The medical device of claim 19, further comprising a coating that includes the MRI contrast agent.
27. The medical device of claim 26, wherein the coating comprises a polymer selected from the group consisting of a hydrophilic polyurethane, an alginate, a polyacrylic-acrylamide copolymer, and hyaluronic acid.
28. The medical device of claim 1, further comprising an air-filled cavity.
29. The medical device of claim 1, further comprising a plurality of contrast agents arranged in a regular pattern.

30. The medical device of claim 29, wherein the contrast agents comprise a T_1 relaxation agent and a material capable of generating a magnetic susceptibility artifact.

31. The medical device of claim 29, wherein the device comprises a radiopaque material or an ultrasound visible portion.

32. The medical device of claim 1, wherein the device is a catheter or a sheath introducer.

33. The medical device of claim 1, wherein the device is a catheter selected from the group consisting of a guide catheter, a balloon catheter, a tumor ablation catheter, an aneurysm catheter, a urology catheter, and a perfusion catheter.

34. The medical device of claim 1, wherein the device is a polymeric guide wire.

35. The medical device of claim 34, wherein the guide wire comprises polyethylene.

36. The medical device of claim 35, wherein the polyethylene has a Young's modulus of greater than about 10 GPa.

37. The medical device of claim 35, wherein the polyethylene has a tensile strength of greater than about 0.5 GPa.

38. A medical device adapted for insertion into body tissue, comprising:
a polymeric shaft having an inner surface defining a lumen; and
an electrically conductive path extending spirally about the polymeric shaft and on the inner surface of the polymeric shaft, a portion of the conductive path being defined by a first conductive coating, wherein the conductive path is capable of being connected to a current source.

39. The medical device of claim 38, wherein the conductive path covers substantially the entire inner surface of the polymeric shaft.
40. A medical device adapted for insertion into the body, comprising:
a polymeric shaft having an inner surface defining a lumen;
an electrically conductive path extending spirally about the polymeric shaft and on the inner surface of the shaft, wherein a first portion of the conductive path is defined by a conductive coating, and a second portion of the conductive path is defined by a metal wire.
41. The medical device of claim 40, wherein the second portion of the conductive path extends on the inner surface of the shaft.
42. A medical device adapted for insertion into the body, comprising:
a polymeric shaft having an inner surface defining a lumen;
an electrically conductive path, a first portion of the path extending spirally in a first direction along the shaft, and a second portion of the path extending spirally in a second direction counter to the first direction along the shaft, the conductive path being defined at least in part by a conductive coating; and
an insulating layer between the first and second portions of the conductive path.
43. A medical device, comprising:
a first plurality of portions comprising a first contrast agent; and
a second plurality of portions comprising a second contrast agent different than the first contrast agent,
wherein the first and second pluralities of portions are arranged in a regular pattern.
44. The device of claim 43, wherein the first contrast agent is a T_1 relaxation agent or a material capable of generating a magnetic susceptibility artifact.
45. The device of claim 43, wherein the portions of the first plurality alternate with the portions of the second plurality.

46. The device of claim 43, further comprising a third portion capable of generating a signal void.

47. The device of claim 43, further comprising a radiopaque portion or a portion that is visible by ultrasound spectroscopy.

48. A medical device, comprising:
a first plurality of portions comprising a first contrast agent; and
a second plurality of portions capable of generating a signal void,
wherein the first and second pluralities of portions are arranged in a regular pattern.

49. The device of claim 48, wherein the first contrast agent is a T_1 relaxation agent or a material capable of generating a magnetic susceptibility artifact.

50. The device of claim 48, wherein the portions of the first plurality alternate with the portions of the second plurality.

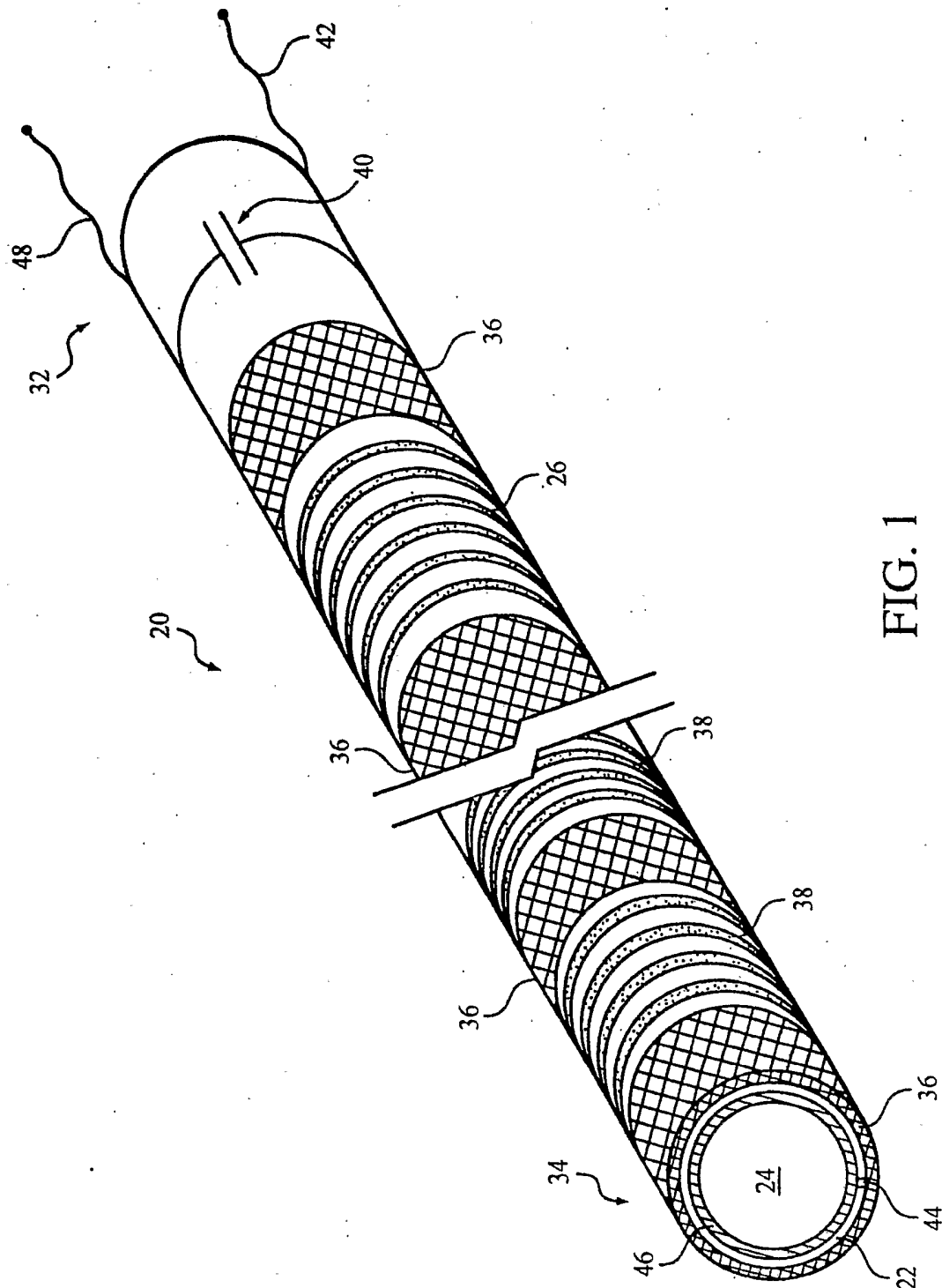

FIG. 1

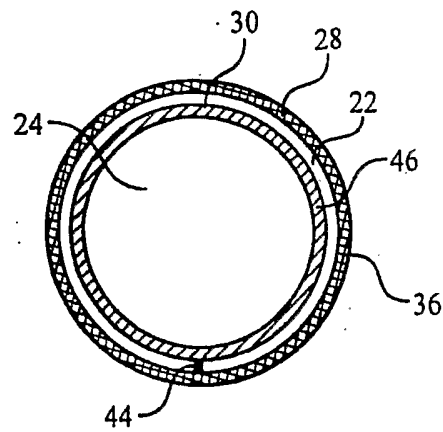

FIG. 2

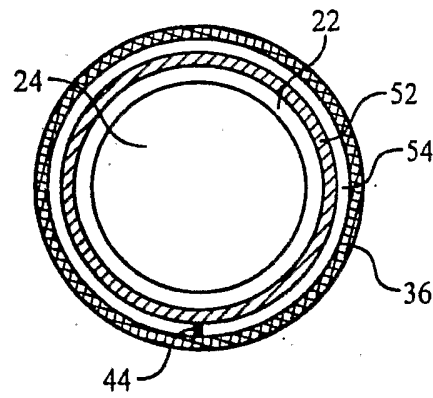

FIG. 3

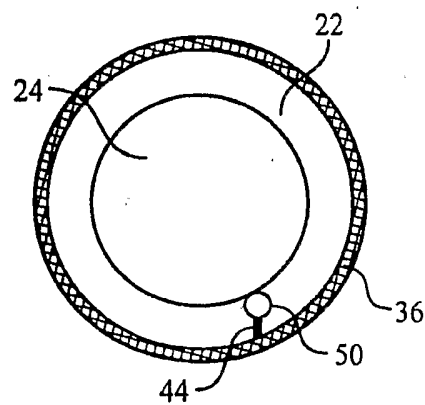

FIG. 4

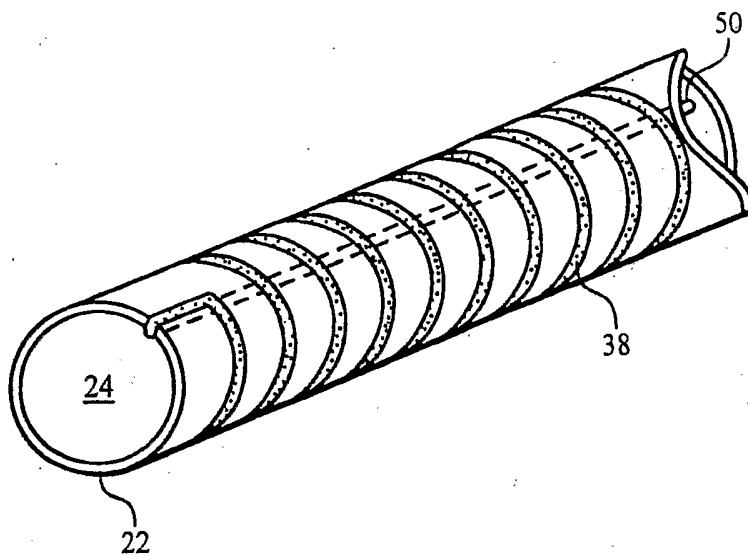

FIG. 5

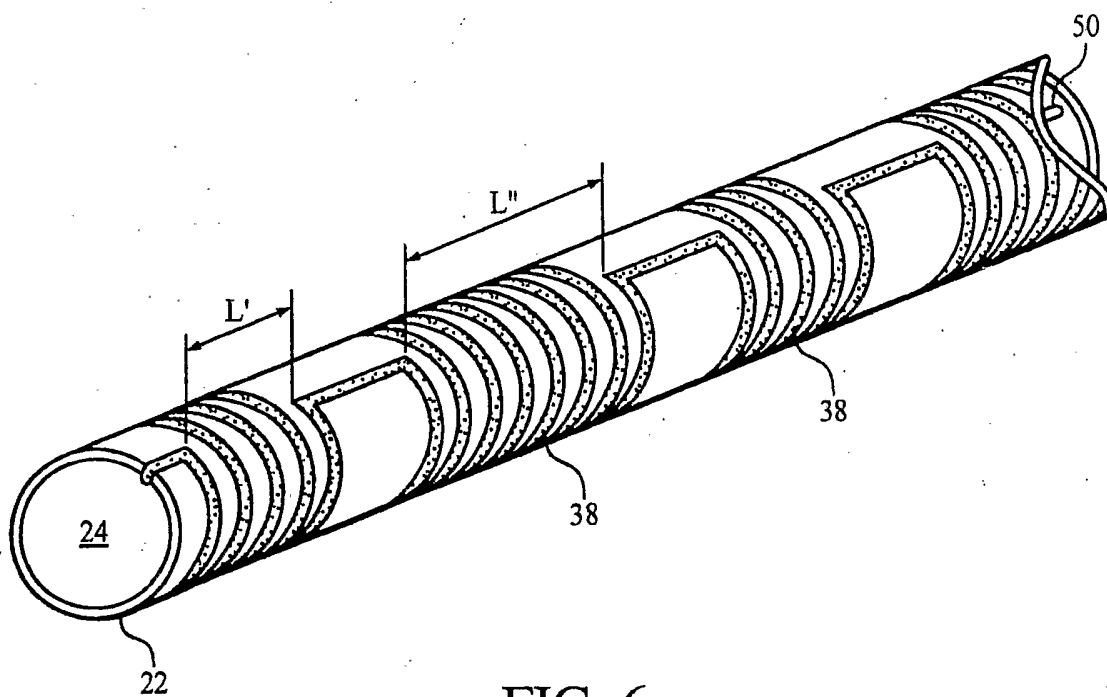

FIG. 6

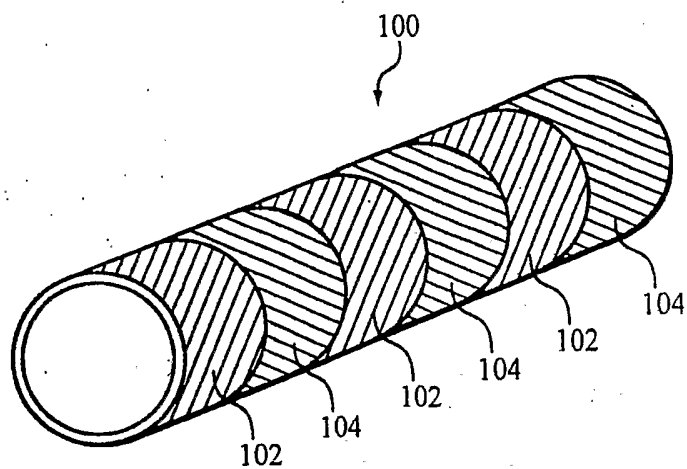

FIG. 7

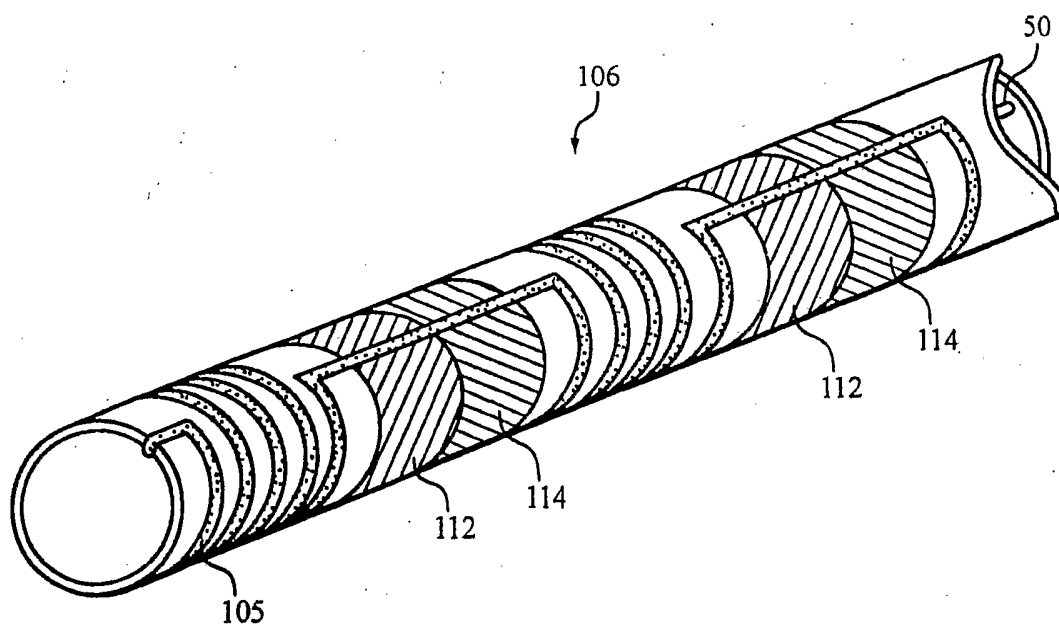

FIG. 8

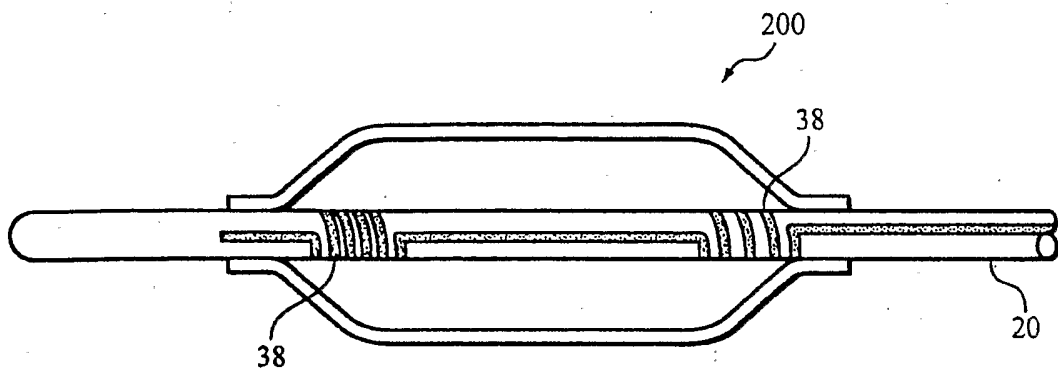

FIG. 9

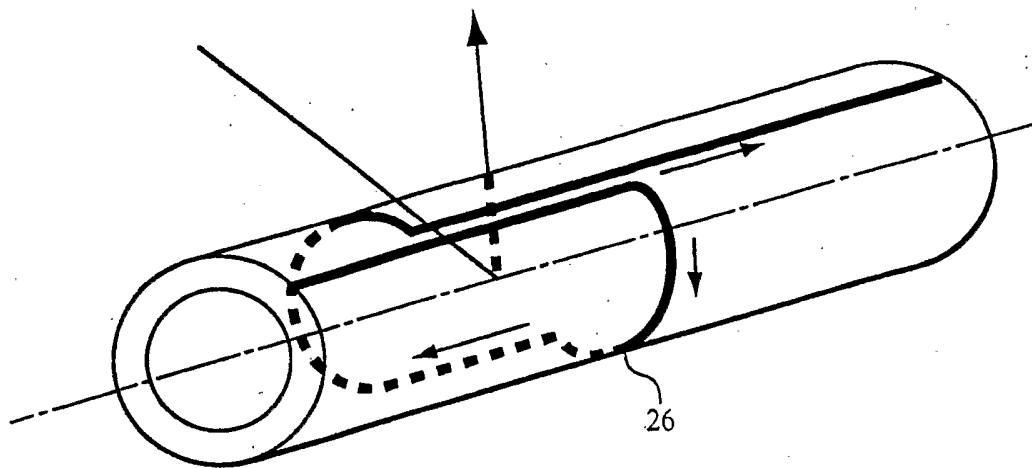

FIG. 10

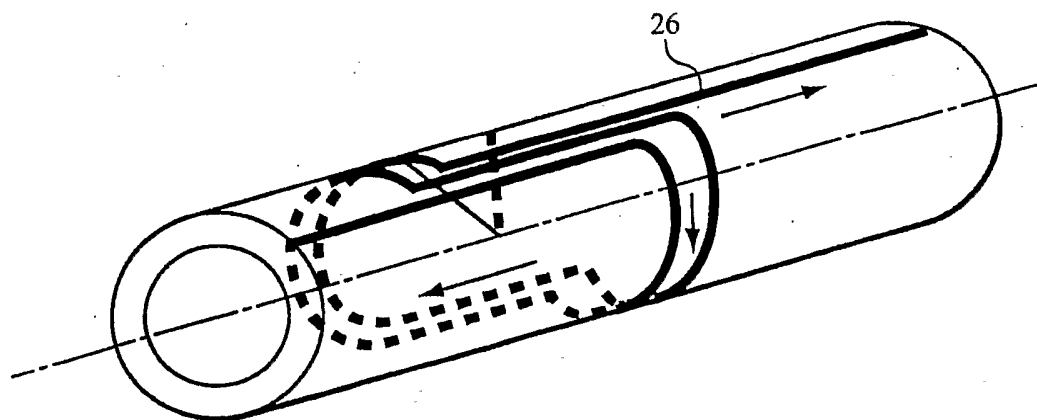

FIG. 11

INTERNATIONAL SEARCH REPORT

International Application No
PCT/US2005/000315

A. CLASSIFICATION OF SUBJECT MATTER IPC 7 G01R33/28 A61M25/00 A61M25/01				
According to International Patent Classification (IPC) or to both national classification and IPC				
B. FIELDS SEARCHED				
Minimum documentation searched (classification system followed by classification symbols) IPC 7 G01R A61B A61M				
Documentation searched other than minimum documentation to the extent that such documents are included in the fields searched				
Electronic data base consulted during the international search (name of data base and, where practical, search terms used) EPO-Internal, WPI Data, PAJ, BIOSIS				
C. DOCUMENTS CONSIDERED TO BE RELEVANT				
Category °	Citation of document, with indication, where appropriate, of the relevant passages	Relevant to claim No.		
X	WO 01/75465 A (CASE WESTERN RESERVE UNIVERSITY; DUERK, JEFFREY, L; ZHANG, QIANG; WEND) 11 October 2001 (2001-10-11) page 7, line 4 - page 9, line 6; figure 4	1-8, 10-16, 18-28, 32-37		
X	US 2003/065267 A1 (SMITH SCOTT RAYMOND) 3 April 2003 (2003-04-03) paragraphs [0024], [0025], [0032], [0033]; figures 2,5 ----- -/--	1-14,16, 26-28, 32-37		
<table style="width: 100%; border: none;"> <tr> <td style="width: 50%; border: none;"> <input checked="" type="checkbox"/> Further documents are listed in the continuation of box C. </td> <td style="width: 50%; border: none;"> <input checked="" type="checkbox"/> Patent family members are listed in annex. </td> </tr> </table>			<input checked="" type="checkbox"/> Further documents are listed in the continuation of box C.	<input checked="" type="checkbox"/> Patent family members are listed in annex.
<input checked="" type="checkbox"/> Further documents are listed in the continuation of box C.	<input checked="" type="checkbox"/> Patent family members are listed in annex.			
° Special categories of cited documents .				
<table style="width: 100%; border: none;"> <tr> <td style="width: 50%; border: none;"> "A" document defining the general state of the art which is not considered to be of particular relevance "E" earlier document but published on or after the international filing date "L" document which may throw doubts on priority claim(s) or which is cited to establish the publication date of another citation or other special reason (as specified) "O" document referring to an oral disclosure, use, exhibition or other means "P" document published prior to the international filing date but later than the priority date claimed </td> <td style="width: 50%; border: none;"> "T" later document published after the international filing date or priority date and not in conflict with the application but cited to understand the principle or theory underlying the invention "X" document of particular relevance, the claimed invention cannot be considered novel or cannot be considered to involve an inventive step when the document is taken alone "Y" document of particular relevance, the claimed invention cannot be considered to involve an inventive step when the document is combined with one or more other such documents, such combination being obvious to a person skilled in the art. "&" document member of the same patent family </td> </tr> </table>			"A" document defining the general state of the art which is not considered to be of particular relevance "E" earlier document but published on or after the international filing date "L" document which may throw doubts on priority claim(s) or which is cited to establish the publication date of another citation or other special reason (as specified) "O" document referring to an oral disclosure, use, exhibition or other means "P" document published prior to the international filing date but later than the priority date claimed	"T" later document published after the international filing date or priority date and not in conflict with the application but cited to understand the principle or theory underlying the invention "X" document of particular relevance, the claimed invention cannot be considered novel or cannot be considered to involve an inventive step when the document is taken alone "Y" document of particular relevance, the claimed invention cannot be considered to involve an inventive step when the document is combined with one or more other such documents, such combination being obvious to a person skilled in the art. "&" document member of the same patent family
"A" document defining the general state of the art which is not considered to be of particular relevance "E" earlier document but published on or after the international filing date "L" document which may throw doubts on priority claim(s) or which is cited to establish the publication date of another citation or other special reason (as specified) "O" document referring to an oral disclosure, use, exhibition or other means "P" document published prior to the international filing date but later than the priority date claimed	"T" later document published after the international filing date or priority date and not in conflict with the application but cited to understand the principle or theory underlying the invention "X" document of particular relevance, the claimed invention cannot be considered novel or cannot be considered to involve an inventive step when the document is taken alone "Y" document of particular relevance, the claimed invention cannot be considered to involve an inventive step when the document is combined with one or more other such documents, such combination being obvious to a person skilled in the art. "&" document member of the same patent family			
Date of the actual completion of the international search <p style="text-align: center; font-size: 1.2em;">27 April 2005</p>		Date of mailing of the international search report <p style="text-align: center; font-size: 1.2em;">22.07.2005</p>		
Name and mailing address of the ISA European Patent Office, P.B 5818 Patentlaan 2 NL - 2280 HV Rijswijk Tel (+31-70) 340-2040, Tx 31 651 epo nl, Fax (+31-70) 340-3016		Authorized officer <p style="text-align: center; font-size: 1.2em;">Rosenblatt, T</p>		

INTERNATIONAL SEARCH REPORT

International Application No
PCT/US2005/000315

C.(Continuation) DOCUMENTS CONSIDERED TO BE RELEVANT		
Category °	Citation of document, with indication, where appropriate, of the relevant passages	Relevant to claim No.
X	<p>GLOWINSKI A ET AL: "CATHETER VISUALIZATION USING LOCALLY INDUCED, ACTIVELY CONTROLLED FIELD INHOMOGENEITIES" MAGNETIC RESONANCE IN MEDICINE, ACADEMIC PRESS, DULUTH, MN, US, vol. 38, no. 2, August 1997 (1997-08), pages 253-258, XP000695506 ISSN: 0740-3194 page 254, left-hand column; figure 2 page 254, right-hand column; figure 3 -----</p>	<p>1-8, 10-14</p>
X	<p>LADD, M E: "Active Visualization - MR Profiling" 1998, INTERVENTIONAL MAGNETIC RESONANCE IMAGING, DEBATIN J F AND ADAM G (EDS.), SPRINGER , BERLIN HEIDELBERG , XP002326354 pages 77-82 pages 77-78; figure 9.2; example 9.2 -----</p>	<p>1-10, 14-18, 34-37</p>

INTERNATIONAL SEARCH REPORT

International application No.
PCT/US2005/000315

Box II Observations where certain claims were found unsearchable (Continuation of item 2 of first sheet)

This International Search Report has not been established in respect of certain claims under Article 17(2)(a) for the following reasons:

1. Claims Nos.:
because they relate to subject matter not required to be searched by this Authority, namely:

2. Claims Nos.:
because they relate to parts of the International Application that do not comply with the prescribed requirements to such an extent that no meaningful International Search can be carried out, specifically:

3. Claims Nos.:
because they are dependent claims and are not drafted in accordance with the second and third sentences of Rule 6.4(a).

Box III Observations where unity of invention is lacking (Continuation of item 3 of first sheet)

This International Searching Authority found multiple inventions in this international application, as follows:

see additional sheet

1. As all required additional search fees were timely paid by the applicant, this International Search Report covers all searchable claims.
2. As all searchable claims could be searched without effort justifying an additional fee, this Authority did not invite payment of any additional fee.
3. As only some of the required additional search fees were timely paid by the applicant, this International Search Report covers only those claims for which fees were paid, specifically claims Nos.:
4. No required additional search fees were timely paid by the applicant. Consequently, this International Search Report is restricted to the invention first mentioned in the claims; it is covered by claims Nos.:

1-28, 32-42

Remark on Protest

- The additional search fees were accompanied by the applicant's protest.
- No protest accompanied the payment of additional search fees

FURTHER INFORMATION CONTINUED FROM PCT/ISA/ 210

This International Searching Authority found multiple (groups of) inventions in this international application, as follows:

1. claims: 1-28, 32-42

medical device comprising a shaft and an electrically
conductive path extending spirally about a portion of the
shaft

2. claims: 43-49, 29-31

medical device comprising a regular pattern of two
pluralities of portions of two contrast agents

INTERNATIONAL SEARCH REPORT

Information on patent family members

International Application No

PCT/US2005/000315

Patent document cited in search report	A	Publication date	AU	Patent family member(s)	Publication date
WO 0175465	A	11-10-2001	AU	5107701 A	15-10-2001
			WO	0175465 A1	11-10-2001
US 2003065267	A1	03-04-2003	CA	2457334 A1	10-04-2003
			EP	1429656 A2	23-06-2004
			JP	2005507691 T	24-03-2005
			WO	03028800 A2	10-04-2003