



- (51) International Patent Classification:  
A61F 5/00 (2006.01) A61M 39/00 (2006.01)
- (21) International Application Number:  
PCT/US2015/037680
- (22) International Filing Date:  
25 June 2015 (25.06.2015)
- (25) Filing Language: English
- (26) Publication Language: English
- (30) Priority Data:  
62/016,921 25 June 2014 (25.06.2014) US
- (72) Inventor; and
- (71) Applicant : ISMAIL, Muhammad, Sami [US/US]; 101 Wyn Oak Circle, Nashville, TN 37205 (US).
- (74) Agents: HOLLOWELL, Kelly, J. et al.; Stites & Harbison PLLC, 1199 North Fairfax Street, Suite 900, Alexandria, VA 22314 (US).
- (81) Designated States (unless otherwise indicated, for every kind of national protection available): AE, AG, AL, AM,

AO, AT, AU, AZ, BA, BB, BG, BH, BN, BR, BW, BY, BZ, CA, CH, CL, CN, CO, CR, CU, CZ, DE, DK, DM, DO, DZ, EC, EE, EG, ES, FI, GB, GD, GE, GH, GM, GT, HN, HR, HU, ID, IL, IN, IR, IS, JP, KE, KG, KN, KP, KR, KZ, LA, LC, LK, LR, LS, LU, LY, MA, MD, ME, MG, MK, MN, MW, MX, MY, MZ, NA, NG, NI, NO, NZ, OM, PA, PE, PG, PH, PL, PT, QA, RO, RS, RU, RW, SA, SC, SD, SE, SG, SK, SL, SM, ST, SV, SY, TH, TJ, TM, TN, TR, TT, TZ, UA, UG, US, UZ, VC, VN, ZA, ZM, ZW.

- (84) Designated States (unless otherwise indicated, for every kind of regional protection available): ARIPO (BW, GH, GM, KE, LR, LS, MW, MZ, NA, RW, SD, SL, ST, SZ, TZ, UG, ZM, ZW), Eurasian (AM, AZ, BY, KG, KZ, RU, TJ, TM), European (AL, AT, BE, BG, CH, CY, CZ, DE, DK, EE, ES, FI, FR, GB, GR, HR, HU, IE, IS, IT, LT, LU, LV, MC, MK, MT, NL, NO, PL, PT, RO, RS, SE, SI, SK, SM, TR), OAPI (BF, BJ, CF, CG, CI, CM, GA, GN, GQ, GW, KM, ML, MR, NE, SN, TD, TG).

Published: — with international search report (Art. 21(3))

(54) Title: BARIATRIC DEVICE AND METHOD

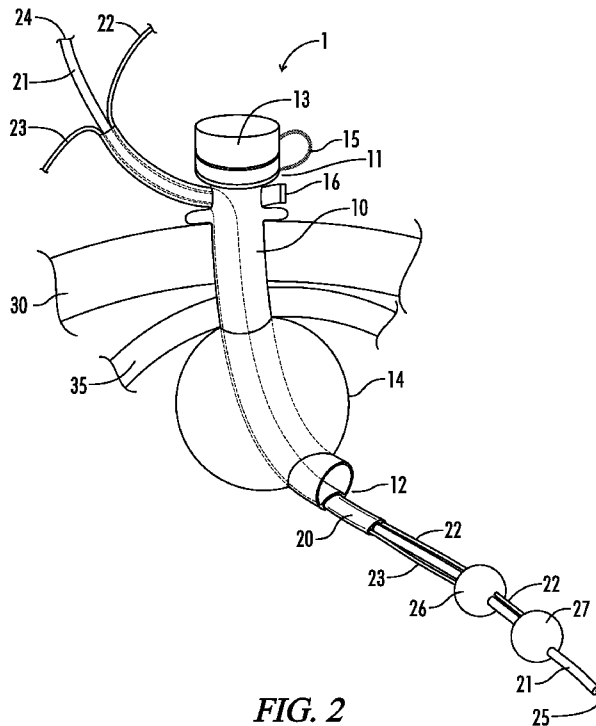

(57) Abstract: A bariatric device and procedure configured to control the amount of food and nutrients entering a person's duodenum and reduce the weight of the person, in one aspect, comprises a gastrostomy tube having a proximal end and a distal end; a feeding tube assembly, said assembly including a feeding tube having a proximal end and a distal end; a gastrostomy tube anchor for securing the distal end of said gastrostomy tube inside the stomach; and a first feeding tube anchor designed to be expanded after the pyloric sphincter so as to anchor the distal end of said feeding tube in the duodenum.

WO 2015/200627 A1

## BARIATRIC DEVICE AND METHOD

5

This application claims benefit under 35 U.S.C. § 119(e) of U.S. Provisional Application No. 62/016,921, filed 25 June 2014, the contents of which are incorporated herein by reference in their entirety.

### TECHNICAL FIELD

10 [0001] The disclosure relates generally to a bariatric device and method. More specifically, the disclosure is directed to a combination trans-abdominal feeding and stomach aspirating device and methods of use for weight loss and obesity treatment.

### BACKGROUND

[0002] The information provided below is not admitted to be prior art to the present  
15 invention, but is provided solely to assist the understanding of the reader.

[0003] Obesity is a major public health issue in the United States. The obesity rate in the United States is among the highest in the world as one out of every three Americans is now considered obese. Obesity has led to over approximately 120,000 preventable deaths and has been cited as a contributing factor to another estimated 100,000-400,000 annual deaths in the  
20 United States. Unfortunately, many Americans are unable to or do not adequately control their weight and require medical intervention to lose weight, while many others desire to lose weight for various aesthetic reasons.

[0004] Numerous medical devices and surgical procedures for cosmetic weight reduction and the treatment of obesity have been proposed. Gastric bypass procedures are one of the  
25 most commonly employed bariatric surgeries in the United States. These procedures typically

involve the division of the stomach into a small pouch and a large pouch, and resection or rerouting of the small intestines to the small pouch to limit the volume of food a person can consume before reaching satiation; the theory being that the smaller the useable stomach volume, the lower the calories that can be absorbed by the body. Other options include sleeve  
5 gastrectomy and gastric banding surgery, which generally involve surgical removal of a large portion of the stomach or mechanical reduction of the size of the stomach, respectively. Still yet other options include direct, controlled feeding into the gastrointestinal tract using an enteral feeding tube alone or in conjunction with an aspirating device for removing excess food from the stomach. For example, one such device is disclosed in U.S. 4,543,089.

10 [0005] However, existing weight reduction devices and procedures are very invasive, have considerable recovery times, often cause nutritional deficiencies, and offer only limited success because they do not cause the subject to permanently change his or her eating habits. In addition, trans-abdominal gastrointestinal feeding and aspirating devices and procedures are prone to clogging by particulate and solid foods and so limit the volume and consistency  
15 of food that can be eaten and removed from the stomach. Moreover, such devices can become dislodged easily and cannot be readily adjusted or accessed.

[0006] Therefore, a need exists for an improved trans-abdominal bariatric device and procedure that can control the amount of food and nutrients passing out of a person's stomach to the duodenum and permit the removal of excess food from the stomach. In addition, what  
20 is needed is an easy to install, minimally invasive bariatric device which may be adjusted or replaced and which will not easily become dislodged from a person's stomach. It is also an object of the present disclosure to provide a bariatric device having a minimal number of separate tubes and or parts inside a person's body. Other objects and advantages will become apparent from the following disclosure.

### SUMMARY

[0007] The present disclosure provides devices and methods for reducing the weight of overweight and obese individuals. More specifically, the disclosure provides bariatric devices and procedures for simultaneously facilitating weight loss and improving healthy eating behaviors while delivering proper nutrition to a person.

[0008] In one aspect of the disclosure, a bariatric device comprises: a gastrostomy tube having a proximal end and a distal end; a feeding tube assembly (optionally at least partially nested within said gastrostomy tube), said assembly including a feeding tube having a proximal end and a distal end; a gastrostomy tube anchor attached to said gastrostomy tube and designed to be expanded inside a person's stomach at the stomach wall to secure the distal end of said gastrostomy tube inside the stomach; and a first feeding tube anchor attached to said feeding tube assembly, said first feeding tube anchor designed to be expanded inside a person's pyloric sphincter (i.e. positioned and expanded beyond/after the pyloric sphincter, within the intestine) so as to secure the distal end of the feeding tube in a person's duodenum. Advantageously, both the gastrostomy tube and feeding tube of the bariatric device can be secured/anchored within a patient, which significantly reduces the chances of the tubes becoming dislodged in a person's stomach. Furthermore, the use of independent anchors for the gastrostomy tube and feeding tube assembly allows the tubes to be manipulated individually, permitting simple and minimally invasive removal and replacement of device components (for example, it is possible for the gastrostomy tube to be removed and replaced whilst the feeding tube remains anchored in position, and *vice versa*).

[0009] Optionally, the gastrostomy tube anchor is a gastrostomy balloon which is designed to be inflated inside a person's stomach. Optionally, the first feeding tube anchor is a first feeding tube balloon designed to be inflated inside/after a person's pyloric sphincter,

and the feeding tube assembly includes a first balloon inflation tube, wherein the first feeding tube balloon is in communication with said first balloon inflation tube.

[0010] Optionally, the bariatric device further comprises a second feeding tube anchor attached to said feeding tube assembly, designed to be positioned and expanded  
5 outside/before the pyloric sphincter so as to secure the distal end of the feeding tube in a person's duodenum in conjunction with said first feeding tube anchor. In such embodiments, the second feeding tube anchor may be a second feeding tube balloon designed to be positioned and inflated before a person's pyloric sphincter, and the feeding tube assembly optionally includes a second balloon inflation tube, wherein the second feeding tube balloon  
10 is in communication with said second balloon inflation tube.

[0011] The bariatric device may comprise: a gastrostomy tube having a proximal end and a distal end; a feeding tube assembly at least partially nested within said gastrostomy tube, said assembly including a feeding tube having a proximal end and a distal end, and first and second balloon inflation tubes; a gastrostomy balloon attached to said gastrostomy tube  
15 and designed to be inflated inside a person's stomach at the stomach wall to anchor the distal end of said gastrostomy tube inside the stomach; and first and second feeding tube balloons in communication with said first and second balloon inflation tubes, said first balloon designed to be inflated inside a person's pyloric sphincter and said second balloon designed to be inflated outside a person's pyloric sphincter so as to anchor the distal end of the feeding  
20 tube in a person's duodenum. Using first and second feeding tube balloons which can be inflated on either side of a person's pyloric sphincter allows both forwards and backwards motion of the feeding tube through the pyloric sphincter to be restricted, and thus provides a way of securing the feeding tube at a desired position within the duodenum.

[0012] In another aspect of the disclosure, the invention provides a feeding tube device,  
25 comprising a feeding tube assembly and feeding tube anchor(s) as described herein. For

example, the feeding tube device comprises: a feeding tube having a proximal end and a distal end, a first balloon inflation tube, and a first feeding tube balloon in communication with said first balloon inflation tube, said first balloon designed to be inflated after a person's pyloric sphincter so as to anchor the distal end of said feeding tube in a person's duodenum.

5 In such embodiments, the feeding tube device may further comprise a second feeding tube balloon, wherein the first and second feeding tube balloons are designed to be inflated on either side of a person's pyloric sphincter so as to anchor the distal end of said feeding tube in a person's duodenum. In such embodiments, the feeding tube device suitably includes a second balloon inflation tube, and the second feeding tube balloon is in communication with  
10 said second balloon inflation tube.

**[0013]** In another aspect of the disclosure, a gastrostomy tube comprises a proximal and a distal end, a sidewall, and a tube support channel on or in the sidewall for receiving a feeding tube assembly, and further comprising a gastrostomy tube anchor attached to said gastrostomy tube and designed to be expanded inside a person's stomach at the stomach wall  
15 to secure the distal end of said gastrostomy tube inside the stomach.

**[0014]** In another aspect of the disclosure, a kit of parts for constructing a bariatric device as described herein comprises a gastrostomy tube and a feeding tube assembly as described herein.

**[0015]** In another aspect of the disclosure, a method for reducing the weight of a person  
20 comprises installing a bariatric device disclosed herein in said person's stomach and limiting the amount of food that passes the stomach into the duodenum using said device to evacuate orally consumed food and directly deposit nutrition to the person's intestinal tract downstream of the stomach.

**[0016]** In another aspect of the disclosure, the present invention provides a method for  
25 reducing the weight of a person for cosmetic (i.e. non-therapeutic) purposes using a bariatric

device disclosed herein, the method comprising limiting the amount of food that passes the stomach into the duodenum using said device to evacuate orally consumed food and directly deposit nutrition to the person's intestinal tract downstream of the stomach.

[0017] In another aspect of the disclosure, a method for delivering nutrients to a person comprises installing a bariatric device disclosed herein in said person's stomach and using said device to evacuate orally consumed food and directly deposit nutrition to the person's intestinal tract downstream of the stomach.

[0018] In another aspect of the disclosure, a method for installing a bariatric device as disclosed herein in a person, comprises (i) inserting said gastrostomy tube into the person's stomach and securing the gastrostomy tube in place by expanding said gastrostomy tube anchor (e.g. inflating a gastrostomy balloon); and (ii) inserting said feeding tube assembly through the person's stomach into the duodenum and securing said feeding tube in place by expanding said first feeding tube anchor after the pyloric sphincter (e.g. inflating a first feeding tube balloon after the pyloric sphincter).

[0019] In another aspect of the disclosure, a method for replacing a gastrostomy tube as described herein with a replacement gastrostomy tube as described herein, comprises (i) retracting said gastrostomy tube anchor and removing said gastrostomy tube and (ii) inserting a replacement gastrostomy tube and expanding the gastrostomy tube anchor of the replacement gastrostomy tube.

[0020] In another aspect of the disclosure, a method for replacing a feeding tube assembly as described herein with a replacement feeding tube assembly as described herein, comprises (i) retracting said first feeding tube anchor (and, if present, retracting said second feeding tube anchor) and removing said feeding tube assembly and (ii) inserting a replacement feeding tube assembly and expanding the first feeding tube anchor (and, if

present, expanding said second feeding tube anchor) of the replacement feeding tube assembly.

[0021] These and other aspects and advantages of the invention described herein will be better understood and appreciated by those skilled in the art by reference to the accompanying drawings briefly described below in conjunction with the following detailed description, wherein certain preferred embodiments including the best mode are described. It is to be understood that the specific devices and processes illustrated in the attached drawings and described in the following detailed description are exemplary embodiments of the inventive concepts defined in the claims below. Hence, specific dimensions and other physical characteristics relating to the embodiments disclosed herein are to be regarded as illustrative in nature and not as restrictive, unless the claims expressly state otherwise.

#### **BRIEF DESCRIPTION OF DRAWINGS**

[0022] **FIG. 1A** is a perspective view of a trans-abdominal bariatric device constructed in accordance with the teachings of the present disclosure;

15 [0023] **FIG. 1B** is a cross section diagram of the bariatric device of **FIG. 1A**;

[0024] **FIG. 2** is a diagram illustrating the bariatric device of **FIG. 1** anchored in the stomach of a human being; and

[0025] **FIG. 3** is a diagram illustrating a pump that can be attached to the bariatric device of **FIG. 1** to evacuate food from a person's stomach through the gastrostomy tube.

20 [0026] **FIG. 4** is a diagram illustrating an external view of the feeding tube assembly of the bariatric device of **FIG. 1** installed in the stomach of a human being; and

[0027] **FIG. 5** is a diagram illustrating an internal view of the bariatric device of **FIG. 1** installed in the stomach of a human being.

[0028] FIG. 6 is a further diagram illustrating an internal view of the bariatric device of FIG. 1 installed in the stomach of a human being.

[0029] FIG. 7 is a diagram illustrating the proximal end of the feeding tube assembly.

### **DETAILED DESCRIPTION**

5 [0028] The following detailed description is presented to enable one of ordinary skill in the art to make and use the invention and to incorporate it in the context of particular applications. It is to be understood that the specific devices and processes illustrated in the attached drawings and described in the following specification are exemplary embodiments of the inventive concepts defined in the claims below. Various modifications, as well as a  
10 variety of uses in different applications, will be readily apparent to those skilled in the art. Thus, specific dimensions and other physical characteristics relating to the embodiments disclosed herein are not to be considered as limiting, unless the claims expressly state otherwise and the invention is not intended to be limited to the embodiments presented, but is to be accorded the widest scope consistent with the principles and novel features disclosed  
15 herein.

[0029] The present disclosure provides means and methods for safely inducing weight loss in overweight and obese individuals. The means and methods disclosed herein provide an easy-to-use, trans-abdominal bariatric device and procedure for strictly controlling the amount of food and nutrition entering a person's gastrointestinal tract that do not require  
20 rescission or rerouting of the person's organs or tissues. The bariatric device disclosed herein is designed to be inserted through the abdominal and stomach walls and generally comprises a feeding tube assembly slidably nested within a larger gastrostomy tube. The device can be installed in a subject with minimal surgery and requires minimal recovery time. In general, the gastrostomy tube is inserted and anchored in the stomach by an inflatable balloon, while a

terminal end of the feeding tube that protrudes from the gastrostomy tube is inserted and anchored in the duodenum by an inflatable balloon positioned after the pyloric sphincter, or by two inflatable balloons positioned on either side of the pyloric sphincter. Due to the large diameter of the gastrostomy tube, the bariatric device will be much less likely to clog when  
5 used to evacuate ground foods from the stomach.

[0030] Optionally, the feeding tube assembly is at least partially nested within the gastrostomy tube. By “at least partially nested within the gastrostomy tube” we mean that at least a part of the feeding tube assembly is positioned within the gastrostomy tube, for example, in the interior of the gastrostomy tube or inset into a sidewall of the gastrostomy  
10 tube. The feeding tube assembly may be accommodated in a tube support channel/track/slot provided on or in the sidewall of the gastrostomy tube, preferably such that the feeding tube can slide relative to the gastrostomy tube within the tube support channel. In such embodiments, the tube support channel may extend along more than 10%, more than 20%, more than 30%, more than 40%, more than 50%, more than 60%, more than 70%, more than  
15 80% or more than 90% of the gastrostomy tube. Advantageously, accommodating the feeding tube assembly within a tube support channel extending along the gastrostomy tube restricts lateral movement of the feeding tube assembly, thus reducing the propensity of the feeding tube to become dislodged from the duodenum. Such a tube support channel may be in an interior sidewall of the gastrostomy tube, or may be in an exterior sidewall of the  
20 gastrostomy tube. The tube support channel may open onto the interior of the gastrostomy tube, or may open to the exterior of the gastrostomy tube. The gastrostomy tube includes an aspirating channel/lumen for aspirating material from a patient’s stomach. In embodiments in which the gastrostomy tube includes a tube support channel, the tube support channel may be separate from the aspirating channel.

[0031] Turning now to the drawings, wherein like reference numbers refer to like elements, FIG. 1A depicts an exemplary trans-abdominal bariatric device **1** constructed in accordance with the present disclosure. The bariatric device **1** comprises a gastro-duodenal feeding tube assembly **20** nested at least partially inside a larger diameter, generally hollow gastrostomy tube **10**, and at least two balloons. In one embodiment, the device comprises three balloons. The balloons are made of medical grade materials standard to the industry and compliant with medical standards, such as silicone. The diameter of the gastrostomy tube may range from 0.5 cm to 5.0 cm, for example, 0.5 cm to 4.0 cm, 0.5 cm to 3.0 cm, 1.0 cm to 2.5 cm, or 1.5 to 2.5 cm. In some embodiments, the diameter of the gastrostomy tube is approximately 1.0, 1.1, 1.2, 1.3, 1.4, 1.5, 1.6, 1.7, 1.8, 1.9, 2.0, 2.1, 2.2, 2.3, 2.4, 2.5, 2.6, 2.7, 2.8, 2.9, 3.0, 3.1, 3.2, 3.3, 3.4, 3.5, 3.6, 3.7, 3.8, 3.9, 4.0, 4.1, 4.2, 4.3, 4.4, 4.5, 4.6, 4.7, 4.8, 4.9, or 5.0 centimeters. In one embodiment, the gastrostomy tube is approximately 2.0 cm. The large diameter of the gastrostomy tube **10** facilitates the evacuation of thick, high consistency or high viscosity foods, including ground solid foods.

[0032] As shown in FIG. 1B the feeding tube assembly **20** comprises a hollow feeding tube **21** and two hollow balloon inflation tubes **22, 23**, held with channels running along the feeding tube assembly. In other embodiments the feeding tube and hollow balloon inflation tubes may be integrally formed as part of the feeding tube assembly, i.e. the feeding tube and first and second balloon inflation tubes may be individual lumens formed as part of the feeding tube assembly body. In one embodiment, the feeding tube assembly has at least one balloon in communication therewith. The feeding tube assembly **20** can be inset or nested in and running parallel to an outside wall of the gastrostomy tube **10**. In the embodiment shown, the outer wall of the gastrostomy tube **10** contains a tube support channel having a space **29** and overhanging lips that partially encompasses the smaller feeding tube assembly **20**. However, in other embodiments, the gastrostomy tube **10** may completely encompass the

feeding tube assembly **20**. In certain embodiments, the feeding tube assembly **20** has a generally elliptical cross section. In other embodiments, the cross section of the feeding tube assembly **20** may be irregular. More generally, the cross section of the feeding tube assembly **20** may be non-circular. When the cross-section of the feeding tube assembly **20** is non-circular, the assembly can be accommodated in a tube support channel having a corresponding shape which limits or prevents rotation of the feeding tube assembly relative to the gastrostomy tube **10**. Advantageously, this restricted rotational movement reduces the chances of the feeding tube assembly becoming twisted and dislodged in a patient's stomach. When properly combined, the feeding tube assembly **20** is able to freely slide against the gastrostomy tube **10** through the space **29**. In some embodiments, the gastrostomy tube **10** may include a releasable lock designed to restrict the sliding movement of the feeding tube assembly **20** within the space **29** and retain the assembly in position against the wall of the gastrostomy tube until the lock is released. In certain embodiments, the releasable lock is disposed on the proximal end **11** of the gastrostomy tube **10**. This arrangement allows the gastrostomy tube **10** or feeding tube assembly **20** to be removed or adjusted as needed without the need to remove any other components of the bariatric device **1** by simply releasing the lock and sliding the relevant tube in and out of position. This makes installation of the bariatric device **1** easier and less invasive than prior art devices and methods. It also makes it easier to clean both the gastrostomy tube **10** and stoma through which the tube extends, since the gastrostomy tube **10** can be temporarily slid out of position to facilitate cleaning without disrupting the position of the feeding tube assembly **20**. In the shown embodiment, the releasable lock is provided by the overhanging lips of the tube support channel, which "grip" the feeding tube assembly **20** when gastrostomy tube balloon **14** (discussed in relation to Fig. 2) is inflated. More specifically, to "lock" the feeding tube assembly **20** in place, the gastrostomy tube balloon **14** is inflated so as to create a constrictive

force which squeezes the overhanging lips of the tube support channel towards one another and thus causes the tube support channel to “grip” the feeding tube assembly **20**. To “unlock” the feeding tube assembly **20** the gastrostomy tube balloon **14** is (at least partially) deflated so as to cause the overhanging lips of the tube support channel to relax and loose  
5 their grip. Stated more generally, the releasable lock may be provided by a deformable jaw on the tube support channel which grips the feeding tube assembly when the gastrostomy tube is inflated.

[0033] Referring now to **FIG. 2**, there is illustrated a diagram of a trans-abdominal bariatric device **1** installed in a person with the gastrostomy tube **10** and nested feeding tube  
10 assembly **20** extending through the abdominal wall **30** and stomach wall **35**. The gastrostomy tube **10** further comprises a distal end **12** and a proximal end **11**. The proximal end **11** is disposed outside the patient’s abdominal wall **30** and comprises a lid **13** for sealing the proximal end **11** and a closeable button **15**. The button **15** is an outlet which may be connected to a vacuum pump for mechanically evacuating by suction the contents of a  
15 person’s stomach into an attached disposable bag or other receptacle for disposal. The distal end **12** of the gastrostomy tube **10** remains open to and is disposed in the person’s stomach. The distal end **12** is also attached to a gastrostomy tube balloon **14** for anchoring the gastrostomy tube **10** in position on the inside of the stomach. The balloon **14** can be inflated through a gastrostomy tube balloon inflation tube (not shown) using the access point **16**  
20 located on the proximal end **11** of the gastrostomy tube **10** between the lid **13** and the abdominal wall **30**. The balloon **14** may be filled with liquid or gas, such as air, water or saline, which is moved through the inflation tube (not shown) into the balloon **14**. The gastrostomy tube balloon **14** may be inflated during installation or afterwards.

[0034] The nested feeding tube assembly **20** is attached to and extends beyond the distal  
25 end **12** of the gastrostomy tube **10** into the patient’s duodenum. Like the gastrostomy tube **10**,

the feeding tube **21** has a distal end **25** and a proximal end **24**, the proximal end **24** being located outside the abdominal wall **30** and sealed by a removeable cap. The distal end **25** terminates in and remains open to the person's duodenum, and is held in position by two feeding tube balloons **26, 27**, including a distal balloon **27** and a proximal balloon **26**. The proximal balloon **26** is located before the pyloric sphincter and the distal balloon **27** is located after the pyloric sphincter.. In the embodiment shown in the figure, the balloons **26, 27** take the form of inflatable sleeves completely surrounding and integrally formed with the feeding tube **21**. To prevent occlusion of the feeding tube **21** by the pressure of the inflated balloons **26, 27**, the sections of the feeding tube **21** inside balloons **26** and **27** are made relatively stiffer than other sections of the feeding tube **21**. This can be achieved, for example, by making the sidewalls of the feeding tube **21** relatively thicker in these sections, selecting a different material for these sections, and/or by subjecting these sections to a stiffening treatment. In other embodiments, the balloons **26, 27** may only partially surround the feeding tube **21**, for example, each balloon may take the form of one or more inflatable cells or pockets distributed around the feeding tube **21**. Although the balloons **26, 27** are formed integrally with the feeding tube **21** in the shown embodiment, it will be appreciated that in other embodiments the balloons **26, 27** may be separately formed from the feeding tube **21**, for example, each balloon **26, 27** may be a separate balloon attached to the feeding tube **21**. In such embodiments, the balloons **26, 27** may be movable (e.g. slidable) relative to the feeding tube **21** over a limited range (e.g. so as to allow a single design to be adapted to suit different patients). For example, one or both balloons **26, 27** may take the form of an inflatable sleeve which the feeding tube can be threaded through, with the sleeves optionally held in position relative to the feeding tube by the constrictive force created when the balloons **26, 27** are inflated.

[0035] Each balloon **26, 27** is in communication with and is inflatable via one of the inflation tubes **22, 23**, which may be connected to an external balloon inflation control device (not pictured). It will be appreciated that in alternative embodiments both balloons can be inflated via a single inflation tube. The balloon inflation tubes **22, 23** are disposed parallel to the feeding tube **21** within the feeding tube assembly **20**, and each extends from outside the abdominal wall **30** to a respective balloon **26, 27**. When the feeding tube balloons **26, 27** are inflated, they anchor/secure the feeding tube assembly **20** relative to the pyloric sphincter. In one embodiment, there is at least one feeding tube balloon anchoring the feeding tube assembly **20**. However, there may be two feeding tube balloons anchoring the feeding tube assembly, one on either side of the pyloric sphincter, so as to restrict forward and backward movement of the feeding tube through the pyloric sphincter.

[0036] Generally, in embodiments having two feeding tube anchors, said anchors are separated by a distance of less than 15 cm, less than 12 cm, less than 10 cm, less than 8 cm, less than 6 cm or less than 4 cm. For example, the feeding tube anchors may be separated by between about 1 to about 15 cm, between about 1 to about 10 cm, or between about 1 to about 5 cm. Advantageously, spacing the feeding tube anchors by this distance allows only a limited amount of movement of the feeding tube back and forth through the pyloric sphincter, which helps to prevent the feeding tube assembly from becoming dislodged. In the embodiment shown in the figures, the distance separating the balloons is the distance measured between the outer surfaces of balloons **26** and **27** at their point of closest approach.

[0037] When fully expanded the first and/or second feeding tube anchors may have a width of at least 5 mm, at least 10 mm, at least 12 mm, at least 15 mm, at least 18 mm, at least 20 mm, at least 22 mm, or at least 25 mm. For example, the feeding tube anchors may have a width of between 10 and 25 mm, or between 15 and 25 mm. Advantageously, feeding tube anchors having these dimensions are wider than the diameter of the pyloric sphincter in

the sphincter's open position, meaning that the positioning of the feeding tube is not affected by pyloric contractions. At least one feeding tube anchor may be sufficiently wide in its fully expanded state to substantially or completely occlude the duodenum. Such a situation is shown in Figure 5, where feeding tube balloons **26** or **27** occlude the duodenum **51** in their inflated states. This prevents the passage of stomach contents to the duodenum **51**, meaning that orally-ingested food and stomach phlegm can be aspirated from the stomach through gastrostomy tube **10** without the need to aspirate further down the digestive tract. Consequently, this provides a way of controlling the amount of food reaching the lower digestive tract.

10 **[0038]** Suitably, the gastrostomy tube **10** does not enter the duodenum **51**. As a result, the gastrostomy tube **10** can be made relatively shorter and wider than the feeding tube assembly **20**, since it is not necessary for the gastrostomy tube to fit within the narrow duodenum **51**. As described above, the relatively large diameter of the gastrostomy tube **10** reduces the propensity of the gastrostomy tube to become clogged during aspiration.

15 Suitably, the length of the gastrostomy tube **10** which is within the body in use may be less than 75%, less than 50%, less than 40% or less than 30% of the length of the feeding tube **21** which is within the body in use. By "length of the gastrostomy tube which is within the body in use" we mean the length as measured from the part of the gastrostomy tube **10** which abuts the patient's stomach wall **35** in use (e.g. the outer surface of a fully-inflated gastrostomy

20 balloon closest to the proximal end **11** of the gastrostomy tube) to the distal end **12** of the gastrostomy tube **10**. By "length of the feeding tube which is within the body in use" we mean the length as measured from the part of the gastrostomy tube which abuts the patient's stomach wall **35** in use to the distal end **25** of the feeding tube **21**.

**[0039]** To remove the gastrostomy tube **10**, the gastrostomy balloon **14** is deflated and

25 the gastrostomy tube **10** is slid off of the feeding tube assembly **20**. A further gastrostomy

tube can then be installed by sliding the gastrostomy tube **10** onto and along the feeding tube assembly **20** until the correct position is reached. The feeding tube balloons **26** and **27** can remain inflated during this procedure, so as to retain the feeding tube **21** in its position within the duodenum **51**, allowing the gastrostomy tube to be replaced in a minimally invasive way.

5 [0040] Similarly, to remove the feeding tube assembly **20**, the feeding tube balloons **26** and **27** are deflated and the feeding tube assembly **20** is slid out of the gastrostomy tube **10**. A further feeding tube assembly can then be installed by slotting the feeding tube assembly **20** through space **29** until the correct position is reached. If the device includes a releasable lock holding the feeding tube assembly **20** in place, the lock should be released before  
10 removal of the feeding tube assembly **20** from the gastrostomy tube **10**. For example, in the shown embodiment, the gastrostomy balloon **14** is partially deflated so as to allow the feeding tube assembly **20** to be removed whilst still securing the gastrostomy tube **10** in position, allowing the feeding tube assembly **20** to be replaced in a minimally invasive way.

[0041] Referring now to **FIG. 3**, there is illustrated a diagram of a manual hand pump **40**  
15 and a releasably attached disposable bag **49** suitable for use with the trans-abdominal bariatric device **1** of **FIG. 1**. The pump **40** comprises a squeezable bulb **47** having an inlet valve **45** and an outlet valve **46**; an inlet tube **43**; and an outlet tube **44**. The bulb **47** is connected to one end of the inlet tube **43** at the inlet valve **45**, and one end of the outlet tube **44** at the outlet valve **46**. The opposite end **41** of the inlet tube connects to the button **15** (see  
20 Fig. 2) of the gastrostomy tube **10** and the opposite end **42** of the outlet tube connects to a disposable bag **49**. When connected to the bariatric device **1** and a disposable bag **49**, a person may squeeze or compress the bulb **47** to suction food out of the stomach and into the bag **49**. When full, the disposable bag **49** may be disconnected from the outlet tube **44**, discarded and replaced with a new bag as needed. The type of vacuum pump used may vary.  
25 Suitable pumps include manual as well as electric and battery powered pumps, and the like.

The type of pump used should provide suction strong enough to evacuate thick or viscous consumed food from the stomach, but not so strong as to damage tissue or organs.

[0042] Referring now to **FIG. 4**, there is provided a diagram illustrating a simplified external view of the feeding tube assembly of the bariatric device of **FIG. 1** installed in the stomach of a human being. The feeding tube assembly **20** extends through the abdomen from outside the body to inside the stomach via a gastrostoma. The point of entry is sealed by a patch **60** through which the feeding tube assembly **20** extends. The feeding tube **21** through which controlled feeding is performed extends from the patch **60** to a point outside the body. The exposed length of feeding tube **21** may be adjusted to suit the person in which it is installed. Also extending outwardly from the patch **60** (outside the body) are the proximal ends of the two balloon inflation tubes **22, 23**. These may be connected to a balloon inflation control (not shown), which can be used to selectively inflate the balloons.

[0043] Referring now to **FIG. 5**, there is provided a diagram illustrating an internal view of bariatric device of **FIG. 1** installed in the stomach of a human being. A cross section of the bariatric device **1** is shown in place of the patch **60** of **FIG 4**. The gastrostomy tube **10** and nested feeding tube assembly **20** pass through the abdomen and stomach wall. The gastrostomy tube **10** terminates in the stomach **52**, while the feeding tube **20** and one balloon inflation tube **22** continues through the stomach **52** and pyloric sphincter **50** into the duodenum **51**. The other balloon inflation tube, **23**, terminates at the bottom of the stomach **52** at the pyloric sphincter **50**. The feeding tube **21** terminates in the duodenum **51** and is attached to two feeding tube balloons, **26, 27**, the proximal balloon **26** located before the pyloric sphincter and the distal balloon **27** located after the pyloric sphincter. Each balloon inflation tube **22, 23** is in communication with a feeding tube balloon **26, 27**. Each feeding tube balloon, **26, 27** is disposed on either side of the pyloric sphincter **50**. Inflation of the balloons via the balloon inflation tubes **26, 27** anchors the feeding tube **21** in the duodenum

50. To form a completed bariatric device **1**, a user slots the feeding tube assembly **20** through the space **29** of a gastrostomy tube **10**, and gently slides the gastrostomy tube **10** into position. Once in position, the gastrostomy balloon **14** of the gastrostomy tube **10** is inflated within the stomach, so as to anchor the gastrostomy tube **10** in place (as shown in Fig. 2).

5 Referring now to **FIG. 6**, there is provided an alternative view of the bariatric device **1** of **FIG. 5** installed in a patient. The figure shows gastrostomy tube **10** anchored within a patient's stomach by gastrostomy balloon **14**, and feeding tube **21** nested within gastrostomy tube **10** extending beyond the end of gastrostomy tube **10** into the duodenum. The feeding tube **21** is held in position by balloons **26**, **27** which have been inflated on either  
10 side of the pyloric sphincter **50** via inflation tubes **22**, **23**.

Referring now to **FIG. 7**, there is provided a diagram of the proximal end of the feeding tube assembly **20**, so as to illustrate how feeding tube balloons **26** and **27** are inflated. Inflation tubes **22** and **23** are shown connected to filling chambers **72** and **73** respectively, with the inflation tubes **22**, **23** and filling chambers **72**, **73** containing a balloon inflation  
15 fluid, in this case, a saline solution. Plungers **74** and **75** positioned within chambers **72** and **73** respectively are used to control the delivery of fluid from the chambers **72** and **73** to the feeding tube balloons **26** and **27** respectively. The plungers **74**, **75** are both connected to a single handle **77**, so as to allow the plungers to be compressed in a single movement. However, handle **77** can be removed to allow each plunger **74**, **75** to be independently  
20 actuated (e.g. to deflate one balloon whilst the other remains inflated). In the embodiment shown, the plungers **74**, **75** have been depressed from position D to position F so as to inflate the balloons **26** and **27** on either side of the pylorus so as to prevent stomach contents from passing to the intestines. To deflate balloons **26** and **27** the plungers **74**, **75** can be lifted from position F to position D. In use, a patient may wish to allow delivery of some stomach  
25 contents to the intestines for short periods; for example, when taking medication or when

drinking. To achieve this, the user can deflate balloon **26** by lifting plunger **74** and partially deflate balloon **27** by lifting plunger **75**, thus allowing passage of the desired contents from the stomach into the intestines whilst the feeding tube **21** remains anchored in position. Once the desired contents have reached the intestines, the user can re-inflate balloons **26** and **27** by  
5 compressing plungers **74** and **75** again. This provides the user with good flexibility to control the material reaching their intestines.

**[0044] Interpretation**

**[0045]** All references, including publications, patent applications, and patents, cited herein are hereby incorporated by reference to the same extent as if each reference were  
10 individually and specifically indicated to be incorporated by reference and were set forth in its entirety herein.

**[0046]** The use of the terms “a” and “an” and “the” and similar referents in the context of describing an invention (especially in the context of the following claims) are to be construed to cover both the singular and the plural, unless otherwise indicated herein or  
15 clearly contradicted by context. The terms “comprising,” “having,” “including,” and “containing” are to be construed as open-ended terms (i.e., “including, but not limited to,”) unless otherwise noted. Recitation of ranges as values herein are merely intended to serve as a shorthand method of referring individually to each separate value falling within the range, unless otherwise indicated herein, and each separate value is incorporated into the  
20 specification as if it were individually recited herein. All methods described herein can be performed in any suitable order unless otherwise indicated herein or otherwise clearly contradicted by context. The use of any and all examples, or exemplary language (e.g., “such as”) provided herein, is intended merely to better illuminate the invention and does not pose a limitation on the scope of the invention (i.e., “such as, but not limited to,”) unless otherwise

claimed. No language in the specification should be construed as indicating any non-claimed element as essential to the practice of the invention.

[0047] While the disclosure above sets forth the principles of the invention disclosed herein, with examples given for illustration only, those skilled in the art will appreciate from 5 the foregoing that various adaptations and modifications of the just described embodiments can be configured in various respects without departing from the scope and spirit of the invention. The inventors expect that skilled artisans will employ various obvious changes in form and detail, and the inventors intend for the invention to be practiced other than as specifically described herein. Accordingly, the invention includes all equivalents and usual 10 and obvious modifications of the subject matter recited in the claims appended hereto as permitted by applicable law. Moreover, any combination of the above-described features and elements in all possible variations hereof is encompassed by the invention unless otherwise indicated herein or otherwise clearly contradicted by context. Therefore, it is to be understood that the invention must be measured by the scope of the appended claims and not by the 15 description of the examples or the preferred embodiments.

**WHAT IS CLAIMED IS:**

1. A bariatric device, comprising:
  - (a) a gastrostomy tube having a proximal end and a distal end;
  - (b) a feeding tube assembly, said assembly including a feeding tube  
5 having a proximal end and a distal end;
  - (c) a gastrostomy tube anchor attached to said gastrostomy tube and designed to be expanded inside a person's stomach at the stomach wall to secure the distal end of said gastrostomy tube inside the stomach; and
  - (d) a first feeding tube anchor means attached to said feeding tube  
10 assembly, said first feeding tube anchor designed to be expanded after a person's pyloric sphincter so as to secure the distal end of the feeding tube in a person's duodenum.
  
2. A bariatric device according to claim 1, wherein the first feeding tube anchor is a first feeding tube balloon designed to be inflated after a person's pyloric sphincter, and the  
15 feeding tube assembly includes a first balloon inflation tube, wherein the first feeding tube balloon is in communication with said first balloon inflation tube.
  
3. A bariatric device according to claim 2, wherein the gastrostomy tube anchor is a gastrostomy balloon which is designed to be inflated inside a person's stomach.  
20
  
4. A bariatric device according to claim 1, further comprising a second feeding tube anchor attached to said feeding tube assembly, wherein said first and second feeding tube anchors are designed to be expanded on either side of a person's pyloric sphincter so as to anchor the distal end of said feeding tube in a person's duodenum.

5. A bariatric device according to claim 3, further comprising a second feeding tube anchor, wherein said first and second feeding tube anchors are designed to be expanded on either side of a person's pyloric sphincter so as to anchor the proximal end of said feeding tube in a person's duodenum.

5

6. A bariatric device according to claim 5, wherein the second feeding tube anchor is a second feeding tube balloon designed to be inflated before a person's pyloric sphincter, and the feeding tube assembly includes a second balloon inflation tube, wherein the second feeding tube balloon is in communication with said second balloon inflation tube.

10

7. A bariatric device according to claim 6, wherein the feeding tube assembly is at least partially nested within said gastrostomy tube.

8. A bariatric device according to claim 7, wherein the feeding tube assembly is  
15 slidably nested within said gastrostomy tube.

9. A bariatric device according to claim 8, wherein the gastrostomy tube includes a  
20 releasable lock designed to restrict the sliding movement of the feeding tube assembly relative to the gastrostomy tube.

20

10. A bariatric device according to claim 8, wherein the feeding tube assembly is  
accommodated in a tube support channel provided in the sidewall of the gastrostomy tube,  
and wherein the feeding tube is slidable relative to the gastrostomy tube within the tube  
support channel.

25

11. A bariatric device according to claim 10, wherein the tube support channel extends along 80% or more of the gastrostomy tube.

12. A bariatric device according to claim 10, wherein the cross-section of the feeding tube assembly is non-circular, and the tube support channel has a corresponding shape which limits or prevents rotation of the feeding tube assembly relative to the gastrostomy tube.

13. A bariatric device according to claim 6, wherein said first and second feeding tube balloons are separated by a distance of between about 1 to about 15 cm.

10

14. A bariatric device according to claim 6, wherein said first and second feeding tube balloons are separated by a distance of between about 1 to about 5 cm.

15. A bariatric device according to claim 6, wherein said first and second feeding tube balloons have a width of between 10 mm to 25 mm.

15

16. A bariatric device according to claim 6, wherein at least one of said first and second feeding tube balloons is sufficiently wide in its fully expanded state to occlude the duodenum in use.

20

17. A bariatric device according to claim 6, wherein the diameter of the gastrostomy tube is between 0.5 to 5.0 cm.

18. A bariatric device, comprising:

25 (a) a gastrostomy tube having a proximal end and a distal end;

(b) a feeding tube assembly at least partially nested within said gastrostomy tube, said assembly having a proximal end and a distal end and including a feeding tube and first and second balloon inflation tubes;

(c) a gastrostomy balloon attached to said gastrostomy tube and designed to be  
5 inflated and anchor the proximal end of said gastrostomy tube inside a person's stomach wall;  
and

(d) first and second feeding tube balloons in communication with said first and  
second balloon inflation tubes, said first and second balloons designed to be inflated on either  
side of a person's pyloric sphincter and anchor the distal end of said feeding tube in a  
10 person's duodenum.

**19.** A feeding tube device, comprising a feeding tube having a proximal end and a  
distal end, a first balloon inflation tube, and a first feeding tube balloon in communication  
with said first balloon inflation tube, said first balloon designed to be inflated after a person's  
15 pyloric sphincter so as to anchor the distal end of said feeding tube in a person's duodenum.

**20.** A feeding tube device according to claim 19, further comprising a second feeding  
tube balloon, wherein the first and second feeding tube balloons are designed to be inflated  
on either side of a person's pyloric sphincter so as to anchor the distal end of the feeding tube  
20 in a person's pyloric sphincter.

**21.** A gastrostomy tube suitable for receiving a feeding tube assembly, comprising a  
proximal and a distal end, a sidewall, and a tube support channel on or in the sidewall for  
receiving said feeding tube assembly, and further comprising a gastrostomy tube anchor

attached to said gastrostomy tube and designed to be expanded inside a person's stomach at the stomach wall to secure the distal end of said gastrostomy tube inside the stomach.

22. A kit of parts for constructing a bariatric device according to claim 6, comprising  
5 a gastrostomy tube and a feeding tube assembly.

23. A method for reducing the weight of a person, comprising installing a bariatric device according to claim 1 in said person's stomach and limiting the amount of food that passes from the stomach into the duodenum using said device to evacuate orally consumed  
10 food and directly deposit nutrition to the person's intestinal tract downstream of the stomach.

24. A method for reducing the weight of a person for cosmetic purposes using a bariatric device according to claim 1, the method comprising limiting the amount of food that passes from the stomach into the duodenum using said device to evacuate orally consumed  
15 food and directly deposit nutrition to the person's intestinal tract downstream of the stomach.

25. A method for delivering nutrients to a person, comprising installing a bariatric device according to claim 1 in said person's stomach and using said device to evacuate orally consumed food and directly deposit nutrition to the person's intestinal tract downstream of  
20 the stomach.

26. A method for installing a bariatric device according to claim 1, comprising:

(i) inserting said gastrostomy tube into the person's stomach and anchoring the gastrostomy tube in place by expanding said gastrostomy tube anchor; and

(ii) inserting said feeding tube assembly through the person's stomach into the duodenum and securing said feeding tube in place by expanding said first feeding tube anchor after the pyloric sphincter.

5    **27.**        A method for replacing a gastrostomy tube in a bariatric device according to claim 1, comprising:

(i) retracting said gastrostomy tube anchor and removing said gastrostomy tube; and

(ii) inserting a replacement gastrostomy tube having the features described in claim 1 and expanding the gastrostomy tube anchor of the replacement gastrostomy tube.

10

**28.**    A method for replacing a feeding tube assembly in a bariatric device according to claim 1, comprising:

(i) retracting said first feeding tube anchor and removing said feeding tube assembly;

and

15       (ii) inserting a replacement feeding tube assembly having the features described in claim 1 and expanding the first feeding tube anchor of the replacement feeding tube assembly.

1/7

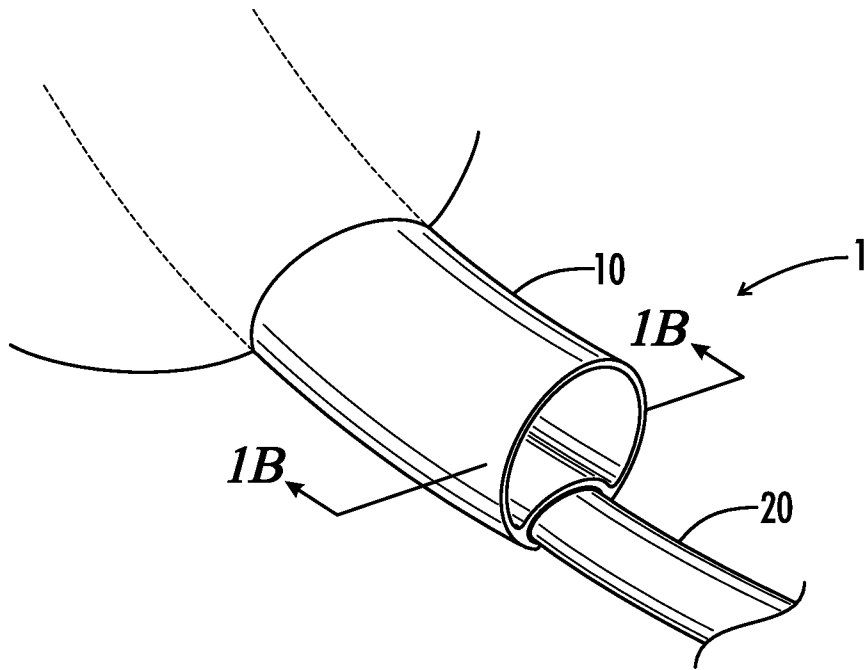

FIG. 1A

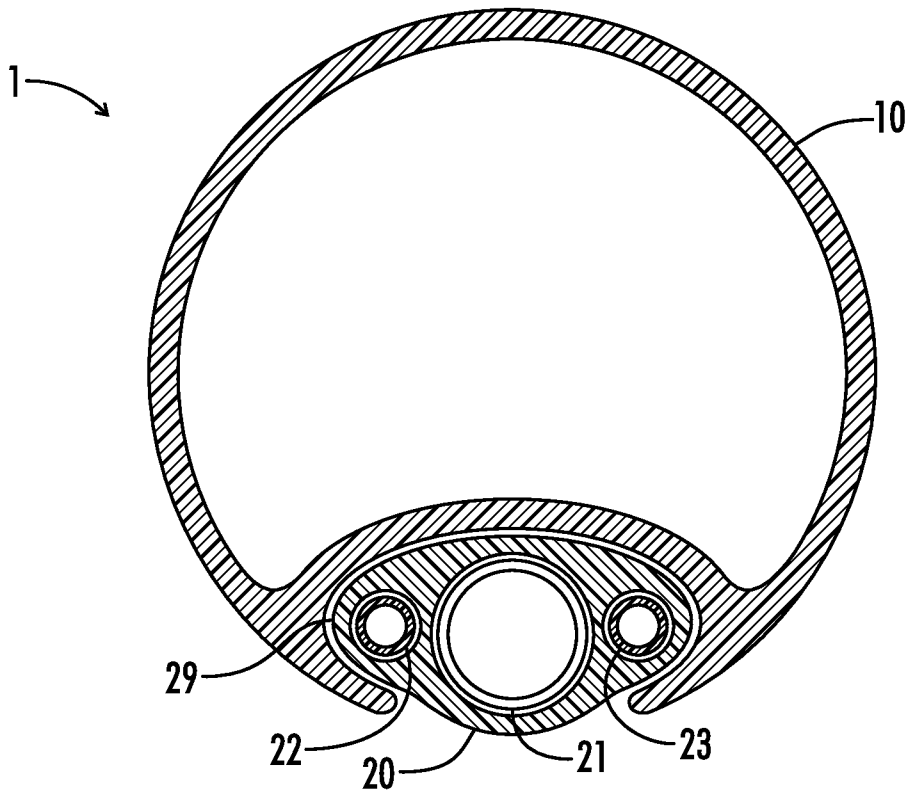
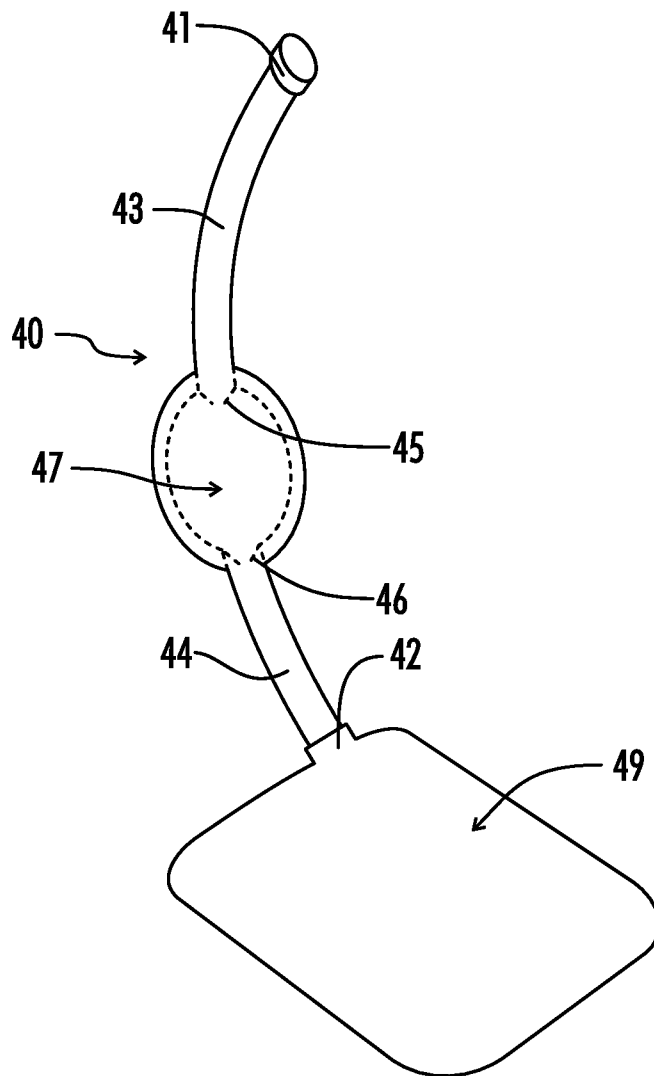

FIG. 1B



3/7



**FIG. 3**

4/7

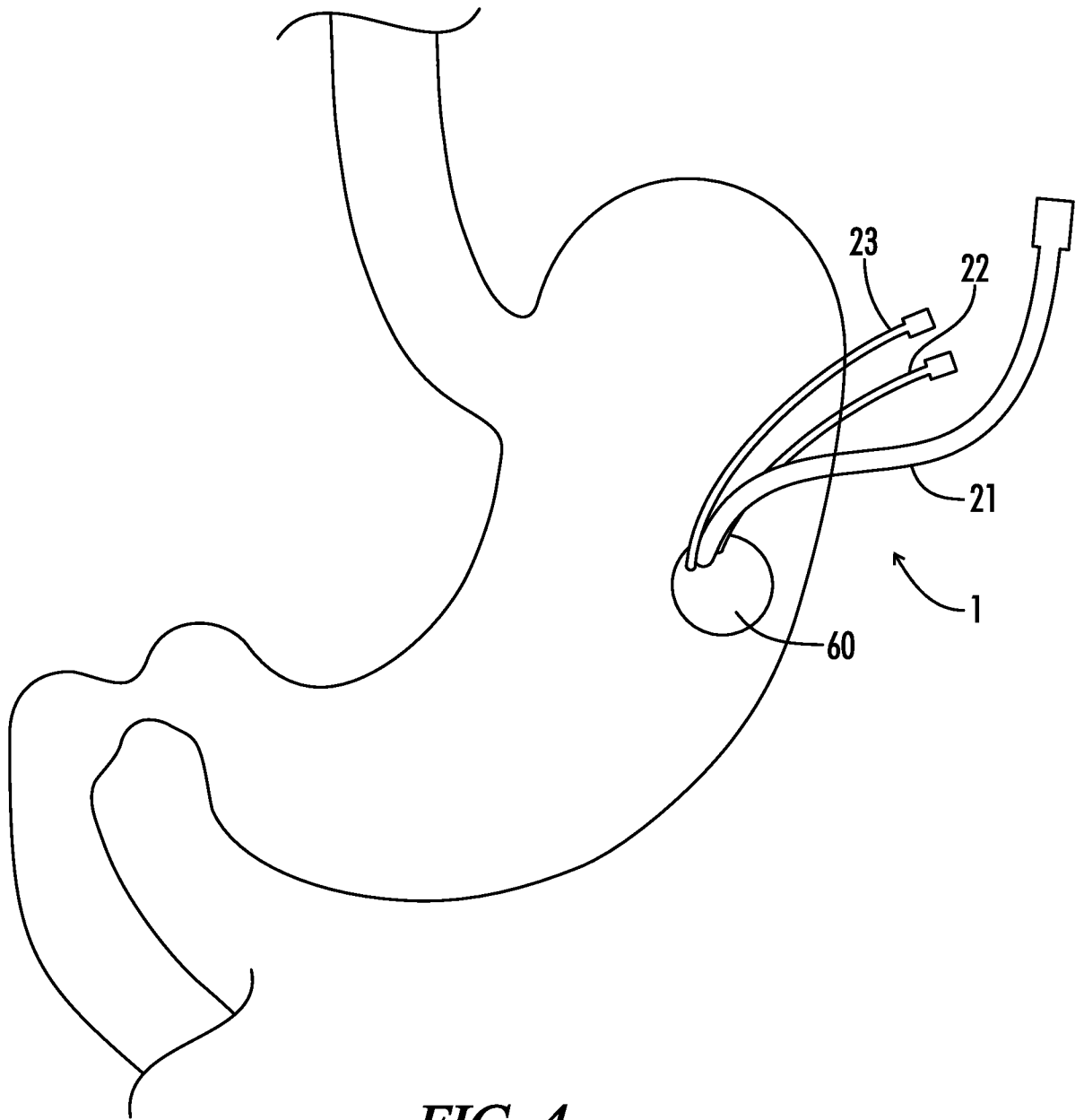

**FIG. 4**

5/7

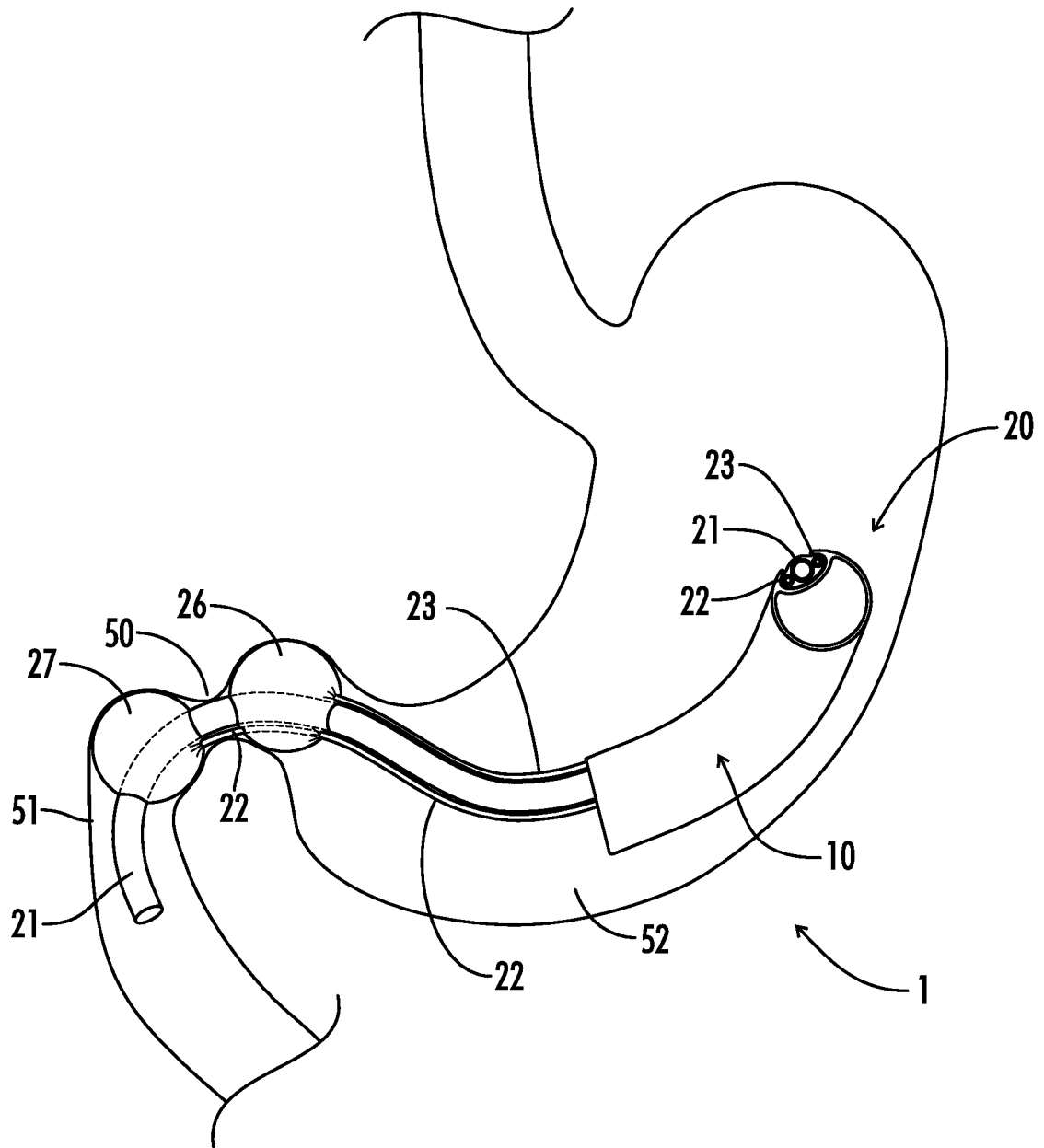

FIG. 5

6/7

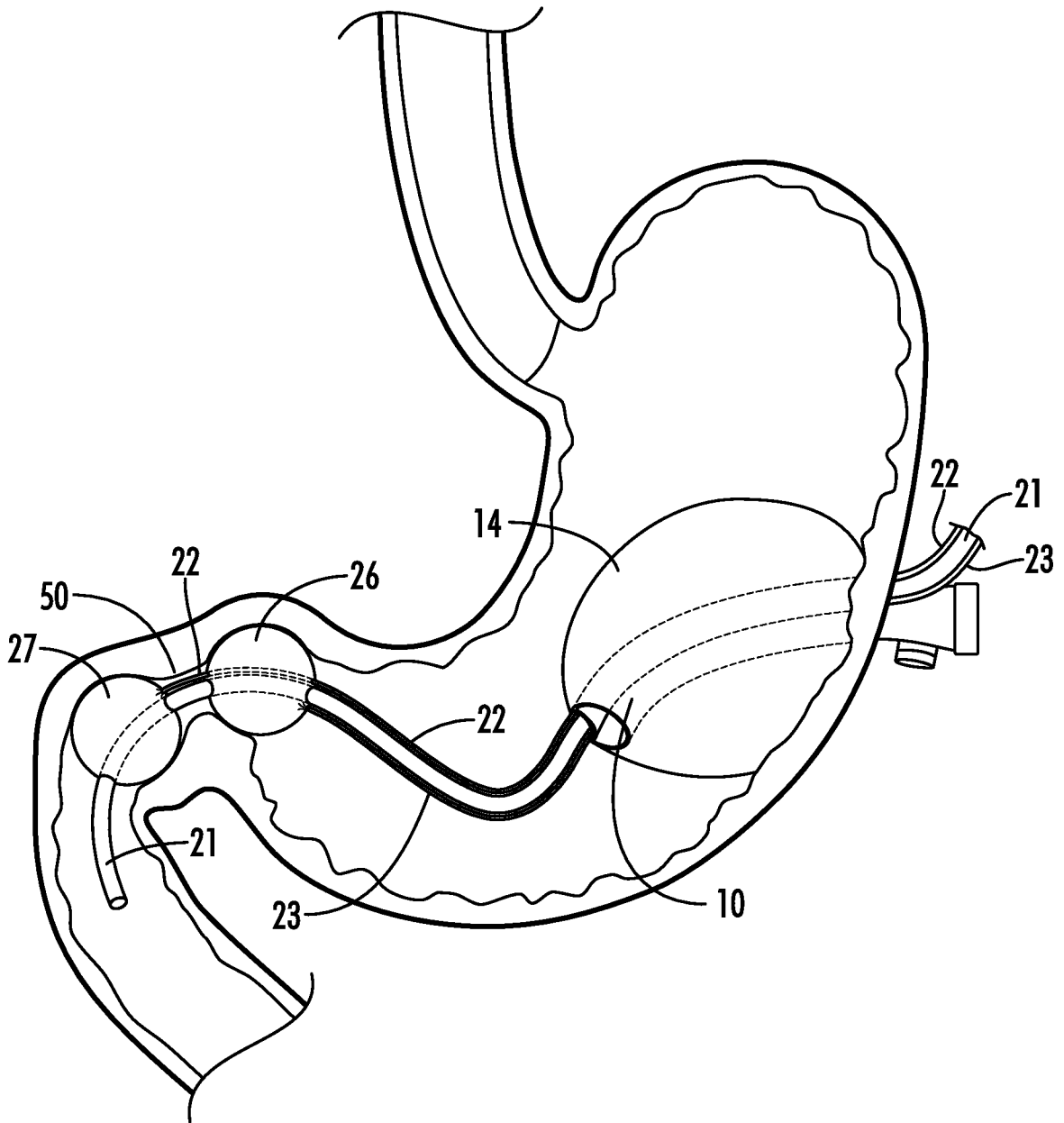
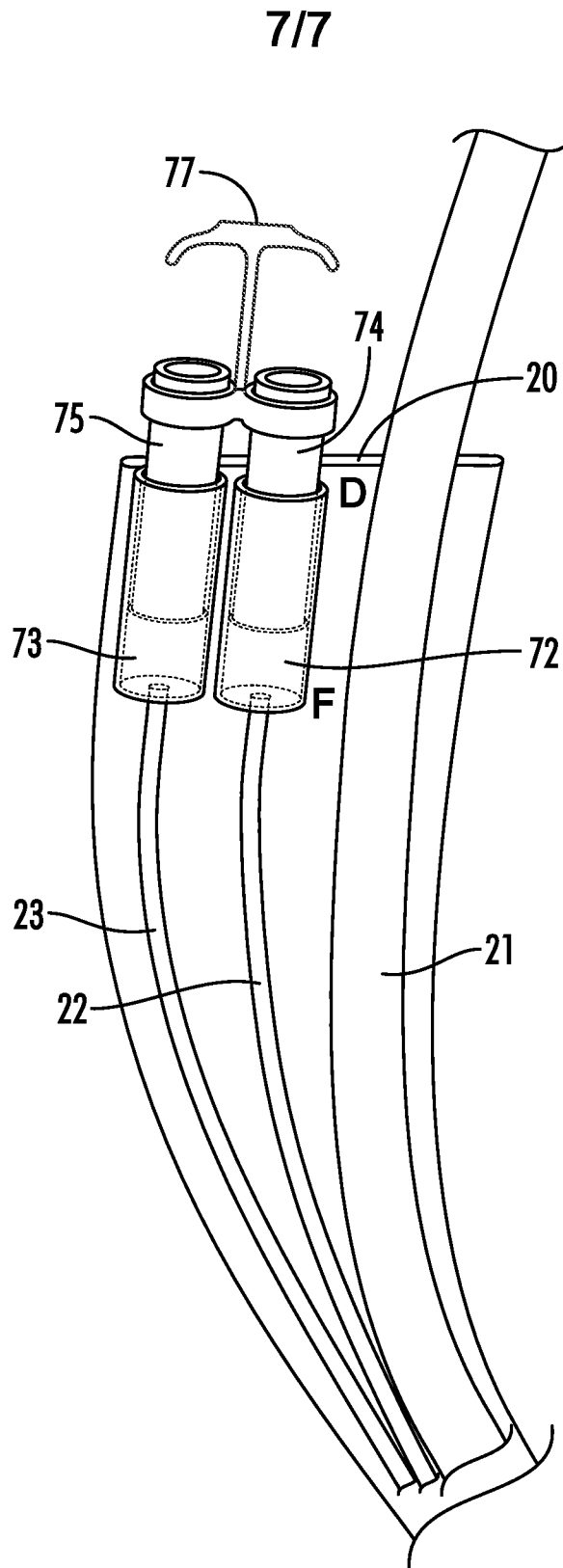

FIG. 6



**FIG. 7**

## INTERNATIONAL SEARCH REPORT

International application No.

PCT/US2015/037680

<b>A. CLASSIFICATION OF SUBJECT MATTER</b> IPC(8) - A61F 5/00; A61M 39/00 (2015.01) CPC - A61F 5/0079; A61M 2039/0255 (2015.09) According to International Patent Classification (IPC) or to both national classification and IPC		
<b>B. FIELDS SEARCHED</b> Minimum documentation searched (classification system followed by classification symbols) IPC(8) - A61B 5/00, 17/00; A61F 5/00; A61M 29/02, 39/00, 39/02 (2015.01) CPC - A61B 2017/00818, 17/3415, 2018/00494, 2018/00553; A61F 5/0036, 5/0076, 5/0079; A61M 2039/0255 (2015.09) Documentation searched other than minimum documentation to the extent that such documents are included in the fields searched USPC - 128/899; 600/29, 31; 601/153; 604/96.01, 907, 909, 910; 606/151, 157 (keyword delimited) Electronic data base consulted during the international search (name of data base and, where practicable, search terms used) PatBase, Google Scholar, PubMed. search terms used: bariatric, device, trans-abdominal, duodenum, adjust, replace, gastrostomy, tube, feeding, anchor, expand, pyloric sphincter, balloon, inflate, method		
<b>C. DOCUMENTS CONSIDERED TO BE RELEVANT</b>		
Category*	Citation of document, with indication, where appropriate, of the relevant passages	Relevant to claim No.
X -- Y	US 2006/0129124 A1 (KANTSEVOY et al) 15 June 2006 (15.06.2006) entire document	19 ----- 1-8, 10-17, 20, 22-28
X -- Y	US 4,668,225 A (RUSSO et al) 26 May 1987 (26.05.1987) entire document	21 ----- 1-8, 10-17, 22-28
Y	US 2006/0276746 A1 (BURNSIDE et al) 07 December 2006 (07.12.2006) entire document	4-8, 10-17, 20, 22
Y	US 5,071,405 A (PIONTEK et al) 10 December 1991 (10.12.1991) entire document	3, 5-8, 10-17, 22
A	CN 202387090 U (QINGZHEN et al) 22 August 2012 (22.08.2012) see machine translation	1-28
A	WO 2011/004335 A2 (DUOCURE, INC) 13 January 2011 (13.01.2011) entire document	1-28
<input type="checkbox"/> Further documents are listed in the continuation of Box C. <input type="checkbox"/> See patent family annex.		
* Special categories of cited documents: "A" document defining the general state of the art which is not considered to be of particular relevance "E" earlier application or patent but published on or after the international filing date "L" document which may throw doubts on priority claim(s) or which is cited to establish the publication date of another citation or other special reason (as specified) "O" document referring to an oral disclosure, use, exhibition or other means "P" document published prior to the international filing date but later than the priority date claimed "T" later document published after the international filing date or priority date and not in conflict with the application but cited to understand the principle or theory underlying the invention "X" document of particular relevance; the claimed invention cannot be considered novel or cannot be considered to involve an inventive step when the document is taken alone "Y" document of particular relevance; the claimed invention cannot be considered to involve an inventive step when the document is combined with one or more other such documents, such combination being obvious to a person skilled in the art "&" document member of the same patent family		
Date of the actual completion of the international search 03 September 2015		Date of mailing of the international search report <b>29 SEP 2015</b>
Name and mailing address of the ISA/ Mail Stop PCT, Attn: ISA/US, Commissioner for Patents P.O. Box 1450, Alexandria, Virginia 22313-1450 Facsimile No. 571-273-8300		Authorized officer Blaine Copenheaver PCT Helpdesk: 571-272-4300 PCT OSP: 571-272-7774