



(12) **EUROPEAN PATENT APPLICATION**

(43) Date of publication:
09.08.2000 Bulletin 2000/32

(51) Int. Cl.⁷: **B41M 5/00**

(21) Application number: **00300799.4**

(22) Date of filing: **02.02.2000**

(84) Designated Contracting States:
**AT BE CH CY DE DK ES FI FR GB GR IE IT LI LU
MC NL PT SE**
Designated Extension States:
AL LT LV MK RO SI

- Yokoyama, Tsutomu
Amagasaki-shi, Hyogo (JP)
- Nojima, Kazuhiro
Kobe-shi, Hyogo (JP)
- Kato, Yoshinori
Ichikawa-shi, Chiba (JP)

(30) Priority: **05.02.1999 JP 2834199**

(71) Applicant: **Oji Paper Co., Ltd.
Tokyo 104-0061 (JP)**

(74) Representative:
**Harrison, Ivor Stanley et al
Withers & Rogers,
Goldings House, 2 Hays Lane
London SE1 2HW (GB)**

(72) Inventors:
• Uchimura, Shunichi
Sanda-shi, Hyogo (JP)

(54) **Coated paper sheet for electro-coagulation printing**

(57) In a coated paper sheet for electro-coagulation printing includes a support paper sheet and at least one coating layer formed on the support sheet, a total pore volume of fine pores contained in the coated paper

sheet and having a pore size of 0.01 to 0.40 μm is controlled to 0.10 to 0.20 ml/g, as determined by a mercury porosimeter.

Fig.1

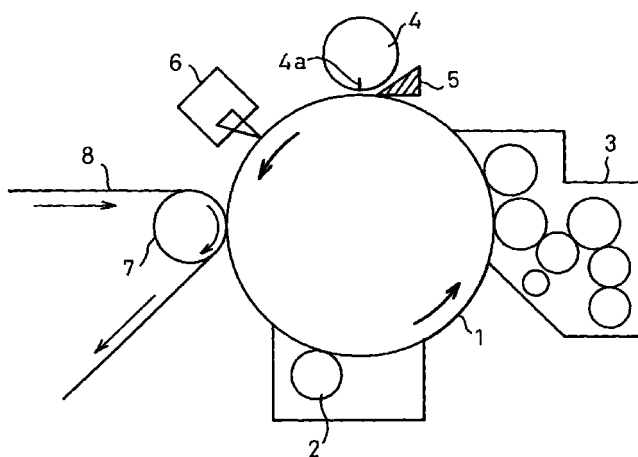

Description

BACKGROUND OF THE INVENTION

5 1. Field of the Invention

[0001] The present invention relates to a coated paper sheet for electro-coagulation printing. More particularly, the present invention relates to a coated paper sheet for electro-coagulation printing, having a high water resistance and capable of recording clear ink images thereon without difficulty in the transfer of ink images.

10

2. Description of the Related Art

[0002] A basic principle of an electro-coagulation printing method (which may be referred to as an elcography) is disclosed in U.S. Patent No. 3,892,645 and Japanese PCT Application Publication No. 4-504,688 (PCT International Publication WO 90/11897). This printing system is a non-printing plate system and uses an aqueous ink having such a property that it is gelled with an electric charge.

15

[0003] In elcography, the specific aqueous ink as mentioned above is applied between a positive cylindrical electrode and a negative electrode, and an electric differential potential corresponding to an imagewise signal is applied between the positive and negative electrodes to generate metal ions, to coagulate portions of the aqueous ink layer formed on the cylindrical electrode by the metal ions, and to cause the coagulated ink colloid to adhere to the surface of the positive cylindrical electrode. By controlling the amount and location of the coagulated ink colloid, a desired colored ink image can be formed on the positive cylindrical electrode surface, and a colored image formed from the electro-coagulated ink can be transferred onto a surface of a recording material under pressure. The constitution of a printing machine for the elcographic printing method will be explained later by referring to an attached drawing. An embodiment of the electro-coagulation printer will be illustrated later.

20

25

[0004] The elcographic printing method is characterized by not using a printing plate. A non-printing plate printing method is advantageous in that no procedure for providing a printing plate is necessary, desired images can be easily printed on a recording material surface in accordance with electric signals corresponding to the desired images, and thus various prints recording images different from each other can be easily prepared for various customers. Especially, the elcographic printing method is advantageous for various lots of prints each in a small number and different from one another.

30

[0005] Also, the elcographic printing method is advantageous in that since the amount of gelled ink, which corresponds to the color density of the images, is proportional to the amount of the electric charge (pulse), ink images having a fine and sharp color tone can be recorded.

35

[0006] Since in the elcography, no dots or halftone dots are used, the color tone of the images can be controlled by regulating the thickness of the ink layers, as in gravure printing. The thickness of the ink layers is proportional to the electric potential-applying time in accordance with the electric signals, and thus the color tone of the images can be accurately controlled. Therefore, the elcographic printing method is suitable for recording colored images.

40

[0007] Conventional printing paper sheets have a satisfactory absorption of oil-based inks, but are poor in absorption and transferring property of the aqueous inks usable for the elcographic printing. Also, when the elcography is applied to multi-color printing, the water component in a first colored aqueous ink applied onto the coating material surface must be quickly absorbed by the coating material, before the second colored ink is applied onto the first colored ink images. If the second colored aqueous ink is applied onto the first colored aqueous ink images before the water component of the first colored aqueous ink images is fully absorbed by the coating material, the second colored aqueous ink is not fully transferred to the coating material and, thus, the desired colored images cannot be obtained. Japanese Unexamined Patent Publication No. 10-131,091 discloses an ink receiving layer containing a pigment comprising synthetic amorphous silica and/or colloidal silica and formed on a support. This specific ink receiving layer can solve the above-mentioned problem to a certain extent.

45

[0008] Generally, to obtain ink images having a high resolution, the recording medium must be selected from high gloss sheets, for example, coated art paper sheets (coated No. 1 grade) and cast-coated paper sheets, having a higher surface smoothness than that of other printing paper sheets for common printings. The conventional printing paper sheets, for example, coated art paper sheets and cast-coated paper sheets have excellent absorbing property for oily inks. However, when these conventional printing sheets are used for the electro-coagulation printing, they exhibit an unsatisfactory absorption of aqueous inks and an insufficient transfer property for the aqueous ink images. Especially, when the conventional printing sheets are employed in the multi-color printing, although the first colored aqueous ink can be absorbed by the printing sheet, the second colored aqueous ink cannot be fully transferred to the printing paper sheet.

55

[0009] Also, from the principle of the electro-coagulation printing, since the specific aqueous ink is gelled with metal

ions generated due to the differential electropotential created between the negative and positive electrodes in accordance with imagewise electric signal, and the coagulated ink colloid is transferred to and fixed on a printing paper surface under pressure, the adhesive property of the ink colloid to the printing paper sheet is very low, especially when water is located between the ink image and the printing paper sheet surface, the adhesive property is particularly low, and thus, the ink images are easily removed from the printing paper sheet surface. Namely, the ink image exhibits a very poor water resistance.

SUMMARY OF THE INVENTION

[0010] An object of the present invention is to provide a coated paper sheet for electro-coagulation printing, which has excellent ink-transferring property and ink absorption and can be recorded with ink images with high clarity and sharpness.

[0011] Another object of the present invention is to provide a coated paper sheet for electro-coagulation printing especially suitable for multi-color printing.

[0012] The above-mentioned object can be obtained by the coated paper sheet of the present invention for electro-coagulation printing.

[0013] The coated paper sheet of the present invention for the electro-coagulation printing comprises a support paper sheet and a coating layer formed on the support paper sheet and comprising a pigment and a binder, the coated paper sheet having a total pore volume of fine pores having a pore size of 0.01 to 0.40 μm , of 0.10 to 0.20 ml/g, as determined by a mercury porosimeter.

[0014] In the coated paper sheet of the present invention for electro-coagulation printing, the coated surface of the coated paper sheet preferably has a smoothness of 1.0 μm or less determined by a microtopograph under a pressure of 3,922,660 Pa (40 kgf/cm²).

[0015] In the coated paper sheet of the present invention for electro-coagulation printing, the pigment in the coating layer preferably includes at least one member selected from the group consisting of calcinated clay, structured kaolin and delaminated clay in an amount of 20 to 70% by weight, based on the total weight of the pigment in the coating layer.

[0016] In the coated paper sheet of the present invention for electro-coagulation printing, the coated surface of the coated paper sheet preferably has a gloss of 70% or more, determined in accordance with Japanese Industrial Standard P 8142.

[0017] In the coated paper sheet of the present invention for electro-coagulation printing, the coated paper sheet having a gloss of 70% or more is preferably one formed by a cast coating method.

BRIEF DESCRIPTION OF THE DRAWING

[0018]

Fig. 1 is an explanatory side view of an embodiment of the electro-coagulation printer to which the recording material of the present invention is applied.

DESCRIPTION OF THE PREFERRED EMBODIMENTS

[0019] The inventors of the present invention have made an extensive studies concerning what problems would be found when conventional coated paper sheets for printing were used for elcography. As a result of the study, the inventors of the present invention have made the following finding.

[0020] Among the conventional printing paper sheets, the coated paper printing sheets having a coating layer formed on a support paper sheet and comprising a pigment, are provided with a dense surface which is substantially free from pores and in which even if, they exist, the size of the pores is small, and they thus exhibit a very high resistance to penetration of the coagulated ink colloid into the inside of the printing paper sheet. If the ink contains water, the printed ink images exhibit a very low resistance to rubbing and thus are easily removed by rubbing. Namely the ink images have a poor water resistance.

[0021] As mentioned above, the elcographic printing method is a very advantageous printing method. However, this method is disadvantageous in that when conventional paper sheets or printing paper sheets are used, the advantages of elcography cannot be fully obtained. For example, when a conventional printing paper sheet is used, prints having excellent printing qualities both in high color density tone and low color density tone cannot be obtained.

[0022] When a conventional coated printing paper sheet is used, the resultant printed images, in a low color density region in which the amount of the coagulated ink colloid is small, exhibit a sufficient color density and thus the resultant prints are satisfactory. However, in a high color density region in which the amount of the coagulated ink colloid is large, the resultant colored ink images exhibit a poor transferring property. Also, when conventional newspaper sheets or

form-printing paper sheets are used, the elcographic printing in the high color density region, in which the amount of the coagulated ink colloid is large, can be satisfactory effected. However, in the low color density region in which the amount of the coagulated ink colloid is small, the elcographic printing is disadvantageous in that non-printed white spots and reduced color density spots are formed.

5 **[0023]** An embodiment of an electro-coagulation printer will be explained by referring to the attached drawing below.

[0024] In Fig. 1, a metal cylinder 1 is used as a positive electrode and it rotates in the direction shown by thick arrows in Fig. 1. The peripheral surface of the positive rotary cylindrical metal electrode 1 is cleaned by a cleaning means 2, and is then coated with a corrosion-preventive coating agent by a conditioning means 3.

10 **[0025]** A portion of the surface-conditioned peripheral surface of the positive rotary cylindrical metal electrode faces a plurality of needle-shaped negative electrodes 4a electrically insulated from each other and independently from each other embedded in and fixed to a print head 4. Into the clearance between the peripheral surface of the positive rotary cylindrical metal electrode 1 and the needle-shaped negative electrodes 4a, an electro-coagulatable ink is applied through an ink feeder 5 to form an ink layer on the peripheral surface of the positive rotary cylindrical metal electrode 1.
15 Then differential electric potentials are applied imagewise between the positive and negative electrodes, in accordance with electric signals corresponding to the images to be printed, to generate metal ions from the positive cylindrical metal electrode.

[0026] The ink layer on the positive cylindrical metal electrode is electrically gelled and coagulated imagewise by the metal ions. The coagulated ink portions are cohered imagewise on the peripheral surface of the positive cylindrical metal electrode 1, and non-coagulated ink portions are selectively removed from the coagulated ink portions by a wiper 6.
20

[0027] A recording material 8 is brought, in the direction shown by the thin arrows into contact with the peripheral surface of the positive cylindrical metal electrode 1 and is pressed toward the peripheral surface of the electrode 1 by a press roll 7. The coagulated colloidal ink images carried on the peripheral surface of the electrode 1 are transferred to the recording surface of the recording material 8.
25

[0028] When multi-colored images are printed, the above-mentioned electro-coagulation printing procedures are repeatedly carried out for each of the multiple colored inks.

[0029] The porous structure of the coated paper sheet is represented by the pore size and total pore volume of fine pores contained in the coated paper sheet and having a specific pore size, determined by a mercury porosimeter in which mercury is pushed into the coated paper sheet. The surface property and the cushioning property of the coated paper sheet can be represented by the smoothness or surface roughness of the coated paper sheet under pressure. The smoothness of the coated paper sheet is determined by a microtopograph under a pressure of 3,922,660 Pa (40 kgf/cm²). This smoothness is referred to as a press-reflection smoothness in the units of μm .
30

[0030] In the present invention, the coated paper sheet must have a porous structure containing fine pores having a pore size of from 0.01 to 0.40 μm , and the total pore volume of the fine pores is in the range of from 0.10 to 0.20 ml/g, preferably 0.11 to 0.20 ml/g, determined by a mercury porosimeter (a mercury press-pushing method).
35

[0031] When the total pore volume of the fine pores having a pore size of 0.01 to 0.40 μm is less than 0.10 ml/g, the resultant recording sheet is disadvantageous in that the ink colloid images with moderate to high color density are transferred to the coated paper sheet with an unsatisfactory degree of transfer, while the ink colloid images with a low color density can be transferred with a satisfactory degree of transfer, and thus the resultant printed images are unsatisfactory as a whole. Especially, in the multi-color printing, the too small pore volume causes the resultant printing paper sheet to exhibit a degraded applicability to the electro-coagulation printing.
40

[0032] When the total pore volume is more than 0.20 ml/g, the resultant coated paper sheet is advantageous in that the aqueous ink absorption is enhanced, but is not preferable in that the color density of the printed ink images is low and the gloss of the images may be decreased.
45

[0033] There is no limitation to the means for adjusting the total pore volume of the fine pore in the coated paper sheet. It was found by the inventors of the present invention that the target coated paper sheet having a total pore volume of 0.10 to 0.20 ml/g can be relatively easily obtained by using, as a pigment component of the coating layer, at least one member selected from calcinated clay, structured kaolin and delaminated clay is employed in an amount of 20 to 70% by solid weight based on the total solid weight of the pigment contained in the coating layer.
50

[0034] Among the conventional pigments usable for the production of the coated paper sheets, the calcinated clay, structured kaolin and delaminated clay can easily form bulky coating layer. Therefore, it is assumed that these pigments contribute to forming a porous coating layer.

[0035] The structured kaolin refers to a kaolin pigment produced by chemically treating kaolin particles and comprising secondary particles each formed from a plurality of primary particles agglomerated with each other. Usually, the structured kaolin is produced from clay and may be combined, in a portion thereof, with titanium dioxide, etc. This composite pigment may be used for the present invention.
55

[0036] The delaminated clay refers to clay particles produced by applying a shearing force to laminated clay parti-

cles to delaminate the laminated clay particles.

[0037] In the formation of the coating layer containing the calcinated clay, structured kaolin and/or delaminated clay, preferably, the coating amount of the layer is controlled, or after drying the coated layer, the resultant coated paper sheet is subjected to a smoothing treatment, to obtain, with a high efficiency the target coated paper sheet having the desired porous structure, namely the total pore volume of the fine pores having a pore size of 0.01 to 0.40 μm , of 0.10 to 0.20 ml/g.

[0038] There is no limitation to the procedure for smoothing the coated paper sheet surface. Usually, a support paper sheet is coated, on the one or two surfaces thereof, with a coating liquid containing the above-mentioned pigment and a binder, to form one or two coating layers, and the resultant coated paper sheet is subjected to a smoothing treatment under pressure using, for example, a super calender. The smoothing procedure may be carried out in the same manner as that for conventional coated paper sheets.

[0039] In the coated paper sheet of the present invention, the dry coating amount of the coating layer on each surface of the support paper sheet is preferably adjusted to 5 to 30 g/m^2 , more preferably 8 to 25 g/m^2 .

[0040] To adjust the total pore volume of the fine pores having a pore size of 0.01 to 0.40 μm to 0.10 to 0.20 ml/g and the press-reflection smoothness measured by microtopograph under a pressure of 3,922,660 Pa (40 kgf/cm^2) to 1.0 μm or less, the smoothing procedure is preferably carried out by using a machine calender, a super calender or soft compact calender, while controlling the smoothing conditions, for example, calender roll temperature, calender roll-nipping pressure or the number of nippings. The smoothing procedures can be effected without specific difficulty.

[0041] Where the coating layer is formed in a dry amount of less than 5 g/m^2 on each surface, the resultant coated paper sheet may have a total pore volume of less than 0.10 ml/g and a press-reflection smoothness of more than 1.0 μm . Also, where the dry amount of the coating layer is more than 30 g/m^2 per surface of the support paper sheet, the resultant coated paper sheet may have an increased total pore volume. However, the resultant coated paper may have an unsatisfactory mechanical strength for printing and too low a producibility.

[0042] Where the dry content of at least one member selected from the calcinated clay, structured kaolin and delaminated clay is less than 20% by weight based on the total dry weight of the pigment, the resultant coated paper sheet may satisfy the specific porous structure, and where it is more than 70% by weight, the resultant coated paper sheet may exhibit an insufficient mechanical strength to printing, and unsatisfactory color density and gloss of the printed ink images.

[0043] The present invention will be further explained below.

[0044] In the electro-coagulation printing system (elcographic system), the gelled ink must be fully transferred to and absorbed in the coating layer of the coated paper sheet, and for this necessity, in the surface of the coating layer (recording surface or printing surface), a plurality of pores for rapidly absorbing the ink (or a water component of the ink) therein must be formed. Also, the aqueous ink usable for the electro-coagulation printing system is gelled between a pair of electrodes, and the content of water contained in the gelled ink is assumed to be 40 to 60% by weight, which is high in comparison with the water content of usual printing inks and is difficult to be transferred and fixed to the printing surface. Therefore, the coated paper sheet, which serves as a recording medium, must absorb therein the water in the gelled ink and to assist the transfer and fixing of the gelled ink to the coated paper sheet.

[0045] For this purpose, it was found in the present invention that in the porous structure of the present invention, it is important to control the pore size of the fine pores to 0.01 to 0.40 μm and to maintain the total pore volume at 0.10 to 0.20 ml/g, as determined by the mercury porosimeter.

[0046] In a preferable embodiment of the coated paper sheet of the present invention for the electro-coagulation printing, the coated paper sheet has a high smoothness and a high cushioning property. The two properties contributes to enhancing the transferred ink-absorbing property of the printing paper sheet.

[0047] In the electro-coagulation printing system, the transferring property of the ink is very important. The images comprising a gelled ink colloid and formed on a metal cylinder are transferred on a surface of the coated paper sheet (recording medium) under pressure by using a press roll. Therefore, the surface smoothness and cushioning property of the coated paper sheet are important for receiving the transferred ink images.

[0048] From the above-mentioned point of view, the inventors of the present invention made extensive studies on a coated paper sheet having enhanced printing properties for the electro-coagulation printing. As a result, it was found that a printing surface having a press-reflection smoothness of 1.0 μm or less determined by a microtopograph under a pressure of 3,922,660 Pa (40 kgf/cm^2) contributes to obtaining a good printing result in which no ink-transfer occurs and ink dots are in the form of a true circle. The reasons for the selection of the pressure of 3,922,660 Pa (40 kgf/cm^2) in the determination of the press-reflection smoothness by the microtopograph is that the ink transfer in the electro-coagulation printing is effected by the press with a press roll, and this pressing condition of the printing has a close relationship to the pressure of 3,922,660 Pa (40 kgf/cm^2) in the press-reflection smoothness measurement by the microtopograph. This relationship was found for the first time by the inventors of the present invention. The press-reflection smoothness under a pressure of 980,665 Pa (10 kgf/cm^2), 1,961,330 Pa (20 kgf/cm^2) or 2,941,995 Pa (30 kgf/cm^2) has a certain relationship to the printing results in a high color density of ink images. However, in moderate to low color den-

sities of ink images, the printing results are variable in response to the type of the coated paper sheets, for example, coated art paper sheets, coated paper sheets (gloss type, dulustered type or matte type) and light weight coated paper sheets, and thus a fixed relationship is difficult to find.

5 **[0049]** Accordingly, the inventors of the present invention found that when the coated paper sheet surface has a press-reflection smoothness of 1.0 μm or less determining by the microtopograph under a pressure of 3,922,660 Pa (40 kgf/cm^2), the coated paper sheet exhibits the above-mentioned excellent printing property as desired.

10 **[0050]** If the smoothness is more than 1.0 μm , the surface of the coated paper sheet may have a high roughness even under pressure and thus may be unsatisfactory in the printing result, for example, the transfer and absorption of the gelled ink colloid may be unevenly conducted, and in a low color density region having a small amount of ink, of the printed paper sheet, the true circle property of the ink dots may be degraded, no ink-transfer may occur, and the color density of the ink images may be reduced.

15 **[0051]** There is no specific lower limit of the press-reflection smoothness of the coated paper sheet of the present invention. Usually, the cast-coated paper sheets, which has a very high smoothness among the coated paper sheets, exhibit a press-reflection smoothness of about 0.05 μm under a pressure of 3,922,660 Pa (40 kgf/cm^2). Therefore, the lower limit of the press-reflection smoothness of the coated paper sheet of the present invention under the above-mentioned pressure is preferably about 0.05 μm . However, there is no certain evidence for a lower limit.

20 **[0052]** To obtain ink images having a high accuracy, a coated paper sheet having a high surface smoothness like, for example, the above-mentioned cast-coated paper sheet having a gloss of 70% or more determined in accordance with Japanese Industrial Standard (JIS) P 8142, is preferably employed. The inventors of the present invention made extensive studies on the coated paper sheets having a high gloss and being satisfactory in printing properties thereof as recording paper sheets having a high smoothness. As a result, it was found that a cast-coating method by which a high smoothness and a high gloss can be easily obtained can be advantageously utilized to produce the recording paper sheet of the present invention.

[0053] The cast-coating method will be explained below.

25 **[0054]** In principle, a coating layer surface having a high gloss and a high smoothness can be obtained while maintaining the bulkiness of the coating layer at a high level, by bringing a coated coating layer kept in a wet condition into contact with a mirror-finished casting metal surface of a cast drum heated to a desired temperature under pressure, by drying the coating layer and by separating the dried coating layer surface from the casting metal surface to transfer the mirror-finished surface condition having a high gloss to the coating layer.

30 **[0055]** Generally, the cast-coated paper sheet can be coated by one of the following three methods, namely a wet cast-coating method in which a coated coating layer in a wetted condition is brought into contact with a mirror-finished and heated casting drum surface under pressure and dried and the dried coating layer surface is separated from the casting drum surface; a re-wet cast-coating method in which a coated coating layer in a wetted condition is dried, the dried coating layer is plasticized with a re-wetting liquid, and brought into contact with a mirror-finished heated casting drum surface under pressure and dried and the dried coating layer surface is separated from the casting drum surface; and a gel cast-coating method in which a coated coating layer in a wetted condition is gelled, the gelled coating layer surface is brought into contact, under pressure, with a mirror-finished heated casting drum surface, and dried and the dried casting layer surface is separated from the casting drum surface. In each casting method, a cast-coated layer surface having a high gloss and a high smoothness is obtained.

35 **[0056]** In the production of the coated paper sheet of the present invention, any of the above-mentioned casting methods may be utilized. Preferably, the re-wet casting method by which only the surface of the coating layer can be smoothed, an excellent gloss can be imparted to the coating layer surface, and the inside portion of the coating layer can be maintained at a porous condition, can be advantageously and easily used for the production of the coated paper sheet of the present invention, because in the re-wet casting method, only the surface portion of the coating layer is plasticized.

40 **[0057]** In the coated paper sheet of the present invention, the coating layer may contain, in addition to at least one member selected from calcinated clay, structured kaolin and delaminated clay, at least one conventional pigment selected from, for example, conventional clay, ground calcium carbonate, precipitated calcium carbonate, titanium dioxide, aluminum hydroxide, silica, satin white, and talc, which are usually used for the coated paper sheets.

45 **[0058]** In the coating layer, the pigment is contained in a mixture with a binder. There is no limitation to the type and amount of the binder. The binder usable for the coating layer may be selected from binders for the conventional coated paper sheets, for example, starch and modified starches, for example, phosphate-esterificated starched, cation-modified starches and engym-modified starches, polyvinyl alcohol, casein, latices of synthetic resins, for example, styrene-butadiene copolymers, vinyl acetate-copolymers, acrylic copolymers, and urethane copolymers. These binders may be used alone or in a mixture of two or more thereof.

50 **[0059]** Usually, in the coating color for forming the coating layer, the binder is preferably contained in an amount of 3 to 50% by dry weight, more preferably 5 to 30% by dry weight. Optionally, the coating color for the coating layer further contains an additive comprising at least one member selected from dispersing agents, pH-adjusting agents, for exam-

ple, sodium hydroxide and aqueous ammonia solutions, anti-foaming agents, antiseptic agents, fluorescent whitening agents, lubricant, dyestuffs, waterproofing agents, fluid-modifiers and colored pigments.

[0060] Particularly, the waterproofing agents are important additives for enhancing the water resistance of the recording paper sheet for the electro-coagulation printing and are not only added to the coating color, but also are applied to the coating layer surface before or after an electro-coagulation printing is applied thereto, and/or are added to an aqueous ink for the electro-coagulation printing, to protect the coated paper sheets or the ink images received on the coated paper sheets from water.

[0061] In the electro-coagulation printing, the conventional waterproofing agent for the coated paper sheets are not always satisfied to enhance the water resistance of the recording paper sheets. For the coated paper sheets for electro-coagulation printing, the waterproofing agent preferably comprises a member selected from epoxy compound-containing waterproofing agents and multi-valent metal compound-containing waterproofing agents. The epoxy compound usable as a waterproofing agent for the present invention contains one or more epoxy groups and are preferably selected from polyepoxy compounds, for example, diglycerol polyglycidylether and glycerol polyglycidylether; diepoxy compounds, for example, polyethylene glycol diglycidylether, polypropylene glycol diglycidylether, trimethylolpropane polyglycidylether, polyglycerol polyglycidylether, and sorbitol polyglycidylether and glycidylester compounds, for example, diglycidylester of adipic acid; and polyamide-epoxide resins. Among these epoxy compounds, the glycerol polyglycidylether, diglycerol polyglycidylether and polyglycerol polyglycidylether are advantageously employed to produce the coated paper sheets of the present invention having the desired properties.

[0062] The multi-valent metal compounds for the waterproofing agents are preferably selected from zinc compounds, for example, zinc sulfate, zinc acetate, zinc formate and zinc carbonate; and zirconium compounds, for example, zirconium acetate, zirconium ammonium carbonate, zirconium sulfate, zirconium nitrate, zirconium iodide and zirconium fluoride. Among the above mentioned compounds, the zirconium compounds, particularly zirconium ammonium carbonate, is advantageously employed.

[0063] The amount of the waterproofing agent to be applied to coating layer surface and/or the ink images transferred to the recording surface is not limited to a specific level. Usually, the coating layer preferably contains the waterproofing agent in a solid amount of 0.5 to 3.0 g/m², more preferably 1.0 to 2.5 g/m². Also, the waterproofing agent contained in the aqueous ink is preferably in a solid amount of 0.1 to 20% by weight, more preferably 0.5 to 15% by weight, based on the total solid weight of the ink. Further, the waterproofing agent is preferably contained in a solid amount of 1 to 20% by weight, more preferably 2 to 15% by weight, based on the solid weight of the coating color.

[0064] There is no limitation to the type of coating devices for coating the support paper sheets with a coating color. Usually, the coating is carried out by using conventional coating devices, for example, air knife coater, blade coater, rod coater, bar coater, roll coaters, for example, gate roll coater and size-press coater and bill blade coater.

[0065] Optionally, the support paper sheet is smoothed by using a machine calender, a soft calender, or a Yankee dryer before coating. Also, as long as the purpose of the present invention can be attained, after the support paper sheet is coated with a coating color for the coating layer and is dried, the resultant coated paper sheet is optionally smoothed by using a machine calender, a soft calender or a super calender.

[0066] There is no limitation to the type of pulp for forming the support paper sheet. Usually, the support paper sheet usable for the present invention is produced from chemical pulps, mechanical pulps and waste paper stocks, which may be used alone or in a mixture of two or more of the above-mentioned pulps. The support paper sheet may be a composite paper sheet comprising two or more paper sheet layers superposed on each other in a paper-forming procedure. In the formation of the paper sheet, the pulp slurry optionally contains one or more additives selected from sizing agents, paper strength-enhancing agents, chemical stabilizing agents, freeness-controlling agents, fillers and coloring materials.

EXAMPLES

[0067] The present invention will be further explained by the following examples which are merely representative and are not intended to restrict the scope of the present invention in any way.

Example 1

[0068] An aqueous pigment slurry was prepared by mixing a dispersing agent (trademark: ARON T-40, made by TOA GOSEI K.K.) in an effective component amount of 0.2 part by weight, sodium hydroxide in an effective component amount of 0.1 part by weight and an anti-foaming agent (trademark: NOPCO 8034L, made by SUN NOPCO CO.) in an amount of 0.1 part by weight into water, and the mixture was further mixed with a pigment consisting of 30 parts by weight of calcinated clay (trademark: ALPHATEX, made by ECC INTERNATIONAL CO.), 30 parts by weight of precipitated calcium carbonate trademark: TP-121-7K, made by OKUTAMA KOGYO K.K.) and 40 part by weight of ground calcium carbonate (trademark: FMT-90, made by FEIMATEC K.K.), while dispersing the mixture in water for 30 minutes,

by stirring by a COWLESS dissolver.

[0069] The aqueous pigment slurry was further added with a binder consisting of 1 part by weight of oxidized starch (trademark: ACE A, made by OJI CORN STARCH K.K.) and 12 parts by solid weight of a styrene-butadiene copolymer latex (trademark: L-1117, made by ASAHI KASEIKOGYO K.K.) and was diluted with water to provide a coating color having a solid content of 60% by weight for a coating layer.

[0070] A fine paper sheet produced by a natural paper-forming system and having a basis weight of 54 g/m² was coated by using a blade coater, on the front and back surfaces thereof, with the above-mentioned coating liquid in a dry amount of 15 g/m² per surface of the paper sheet, and dried.

[0071] The resultant both surface-coated paper sheet was calendered by a 7-nip super calender provided with metal rolls heated to a surface temperature of 80°C.

[0072] A both surface-coated paper for electro-coagulation printing was obtained.

Example 2

[0073] A both surface-coated paper sheet for electro-coagulation printing was produced by the same procedures as in Example 1 with the following exceptions.

[0074] An aqueous pigment slurry was prepared by mixing a dispersing agent (trademark: ARON T-40, made by TOA GOSEI K.K.) in an effective component amount of 0.2 part by weight, sodium hydroxide in an effective component amount of 0.1 part by weight and an anti-foaming agent (trademark: NOPCO 8034L, made by SUN NOPCO CO.) in an amount of 0.1 part into water, and the mixture was further mixed with a pigment consisting of 60 parts by weight of structured kaolin (trademark: LOTOPRINT, made by HEUBA K.K.), and 40 parts by weight of precipitated calcium carbonate (trademark: TP-123-CS, made by OKUTAMA KOGYO K.K.), while dispersing the mixture in water for 30 minutes, by stirring by a COWLESS dissolver.

[0075] The aqueous pigment slurry was further added with a binder consisting of 1 part by weight of oxidized starch (trademark: ACE A, made by OJI CORN STARCH K.K.) and 15 parts by solid weight of a styrene-butadiene copolymer latex (trademark: SN-101B, non-alkali swelling type Tg = -5°C, made by SUMIKA A & L K.K.) and was diluted with water to provide a coating color having a solid content of 60% by weight for a coating layer.

Example 3

[0076] A both surface-coated paper sheet for electro-coagulation printing was prepared by the same procedures as in Example 2, with the following exceptions.

[0077] In the preparation of the coating color for the coating layer, the pigment consisted of 40 parts by weight of a delaminated clay (trademark: NEW CLAY, made by ENGELHARD CO.) 40 parts by weight of a precipitated calcium carbonate (trademark: TP-123-CS, made by OKUTAMA KOGYO K.K.) and 20 parts by weight of a ground calcium carbonate (trademark: FMT-90, made by FEIMATEC CO.).

Example 4

[0078] A both surface-coated recording sheet for electro-coagulation printing was prepared by the same procedures as in Example 2, with the following exceptions.

[0079] In the preparation of the coating color for the coating layer, the pigment consisted of 20 parts by weight of a calcinated clay (trademark: ANSILEX, made by ENGELHARD CO.) 40 parts by weight of a structured kaolin (trademark: LOTOPRINT, made by HEUBA K.K.) and 40 parts by weight of a precipitated calcium carbonate (trademark: TP-123-CS, made by OKUTAMA KOGYO K.K.).

Example 5

[0080] A both surface-coated recording sheet for electro-coagulation printing was prepared by the same procedures as in Example 4, with the following exceptions.

[0081] In the preparation of the coating color for the coating layer, the calcinated clay was replaced by the same delaminated clay as in Example 3.

[0082] Also, in the calender treatment, the 7-nip super calender having the metal rolls heated to a surface temperature of 80°C was replaced by a 4 nip soft calender having metal rolls heated to a surface temperature of 120°C.

Example 6

[0083] A both surface-coated recording sheet for electro-coagulation printing was prepared by the same proce-

dures as in Example 2, with the following exceptions.

[0084] In the preparation of the coating color for the coating layer, the pigment consisted of 20 parts by weight of the same calcinated clay as in Example 4, 20 parts by weight of the same structured kaolin as in Example 2, 20 parts by weight of the same delaminated clay in Example 3 and 40 parts by weight of the same precipitated calcium carbonate as in Example 2.

Example 7

[0085] A both surface-coated recording sheet for electro-coagulation printing was prepared by the same procedures as in Example 5, with the following exceptions.

[0086] In the coating procedure for the coating layers, the coating color was coated on both the surfaces of the coated paper sheets to form front and back coating layers each in a dry amount of 8 g/m².

Example 8

[0087] A both surface-coated recording sheet for electro-coagulation printing was prepared by the same procedures as in Example 5, with the following exceptions.

[0088] In the coating procedure for the coating layers, the coating color was coated on both the surfaces of the coated paper sheet to form front and back coating layers each in a dry amount of 23 g/m².

Example 9

[0089] An aqueous pigment slurry having a solid content of 40% by weight was prepared by mixing 60 parts by weight of precipitated calcium carbonate (trademark: BRILLIANT S15, made by SHIRAISHI KOGYO K.K.) with 20 parts by weight of amorphous silica (trademark: Finesil X-37, made by TOKUYAMA SODA K.K.), 20 parts by weight of the same calcinated clay in Example 4 and 0.5 part by weight of a dispersing agent comprising sodium polyacrylate (trademark: ALON A-9, made by TOA GOSEI K.K.), in water.

[0090] A casein solution was prepared by mixing 100 parts by weight of casein with 15 parts by weight of 28% aqueous ammonium solution and dissolving the casein mixture in hot water at a temperature of 70°C. A cast-coating color was prepared by mixing the aqueous pigment slurry with 5 parts by weight of the casein solution and a styrene-butadiene copolymer latex (trademark: L-1392, made by ASAHI KASEIKOGYO K.K.) in a solid amount of 15 parts by weight; adjusting the pH value of the mixture to 10.5 by adding an aqueous ammonia solution; and adding, to the pH-adjusted mixture, a 10% aqueous zinc sulfate solution in a solid amount of 1.5 parts by weight.

[0091] The cast-coating color was coated by using an air knife on the front surface of a paper sheet produced by an acid paper-forming procedure and having a basis weight of 60 g/m², in a dry amount of 25 g/m², and then dried. The resultant coated layer was re-wetted with a 2% aqueous ammonium stearate solution, and brought into contact under pressure with a mirror-finished casting drum surface at a surface temperature of 105°C, to smooth the rewetted coating layer surface and dry the rewetted coating layer, and then resultant coated sheet was separated from the casting drum. A cast-coated paper sheet for electro-coagulation printing was obtained.

Example 10

[0092] A cast-coated paper sheet for electro-coagulation printing was produced by the same procedures as in Example 9 with the following exceptions.

[0093] In the preparation of the aqueous pigment slurry, the pigment consisted of 50 parts by weight of the same precipitated calcium carbonate (trademark: Brilliant S15) as in Example 9, 20 parts by weight of kaolin (trademark: UW-90, made by ENGELHARD CO.) and 30 parts by weight of the same calcinated clay (trademark: ANSILEX) in Example 4.

Example 11

[0094] A two surface-coated paper sheet for electro-coagulation printing was produced by the same procedures as in Example 1 with the following exceptions.

[0095] In the preparation of the coating color for the coating layer, the pigment slurry in a solid amount of 100 parts by weight was mixed with an epoxy waterproofing agent (trademark: DENACOL PC-1000, made by NAGASE KASEI K.K.) comprising glycerol polyglycidylether in a solid amount of 2 parts by weight.

Comparative Example 1

[0096] A two surface-coated paper sheet for electro-coagulation printing was produced by the same procedures as in Example 2 with the following exceptions.

5 **[0097]** In the aqueous pigment slurry, the pigment consisted of 15 parts by weight of the same calcinated clay as in Example 1, 65 parts by weight of kaolin (trademark: UW-90, made by ENGELHARD CO.) and 20 parts by weight of the same precipitated calcium carbonate as in Example 2.

Comparative Example 2

10

[0098] A two surface-coated paper sheet for electro-coagulation printing was produced by the same procedures as in Example 2 with the following exceptions.

[0099] In the aqueous pigment slurry, the pigment consisted of 75 parts by weight of the same structured kaolin as in Example 2, and 25 parts by weight of the same ground calcium carbonate as in Example 1.

15

Comparative Example 3

[0100] A two surface-coated paper sheet for electro-coagulation printing was produced by the same procedures as in Example 2 with the following exceptions.

20 **[0101]** In the aqueous pigment slurry, the pigment consisted of 40 parts by weight of the same delaminated clay as in Example 3, 40 parts by weight of the same kaolin as in Comparative Example 1, and 20 parts by weight of the same precipitated calcium carbonate as in Example 2. Also, the coating layer was formed in a dry weight of 3 g/m² on each surface of the support paper sheet.

25 Comparative Example 4

[0102] A two surface-coated paper for electro-coagulation printing was produced by the same procedures as in comparative Example 3 with the following exceptions.

30 **[0103]** The coating amount of the coating liquid on each surface of the paper sheet was changed to 32 g/m² by dry weight.

Comparative Example 5

35 **[0104]** A two surface-coated paper sheet for electro-coagulation printing was produced by the same procedures in Example 2, with the following exceptions.

[0105] In the preparation of the coating color, the pigment consisted of 35 parts by weight of kaolin (trademark: Rastra, made by ENGELHARD CO.), 25 parts by weight of ground calcium carbonate (trademark: HYDROCurve 90, made by BIHOKU FUNKAROGYO K.K.), 25 parts by weight of ground calcium carbonate (trademark: HYDROCURVE 60, made by BIHOKU FUNKAKOGYO K.K.) and 15 parts by weight of precipitated calcium carbonate (trademark: TP-40 121-MS, made by OKUTAMA KOGYO K.K.), and the binder consisted of 3 parts by weight of oxidized starch (trademark: ACE A, made by OJI CORN STARCH K.K.) and 10 parts by solid weight of a styrene-butadiene copolymer latex (trademark: T-2550K, made by JSR CO.). Also, the smoothing treatment was carried out by using a 11 nip super calender.

45 Comparative Example 6

[0106] A two surface-coated paper sheet for electro-coagulation printing was produced by the following procedures.

Preparation of a coating color for an undercoat layer

50

[0107] An aqueous pigment slurry having a solid content of 72% by weight was prepared by dispersing a mixture of 10 parts by weight of kaolin (trademark: HT, made by ENGELHARD CO.), with 90 parts by weight of ground calcium carbonate (trademark: HYDROCURVE 60, made by BIHOKU FUNKAKOGYO K.K.) and 0.2 part of sodium polyacrylate as a dispersing agent, in water by using a Cowless dissolver.

55 **[0108]** A coating color having a solid content of 65% by weight was prepared by mixing the aqueous pigment slurry with 10 parts by solid weight of oxidized starch (trademark: ACE A, made by OJI CORN STARCH K.K.), 5 parts by solid weight of a styrene-butadiene copolymer latex (trademark: T-2550K, made by JSR Co.) and diluting the mixture with water.

Preparation of a coating color for uppercoat layer

5 **[0109]** An aqueous pigment slurry having a solid content of 66% by weight was prepared by dispersing a mixture of 40 parts by weight of kaolin (trademark: UW-90, made by ENGELHARD CO.), with 20 parts by weight of precipitated calcium carbonate (trademark: TP-221-GS, made by OKUTAMA KOGYO K.K.) 40 parts by weight of ground calcium carbonate (trademark: FMT-90, made by FEIMATEC CO.) and 0.2 part of sodium polyacrylate, as a dispersing agent in water by using a Cowless dissolver.

10 **[0110]** A coating color having a solid content of 60% by weight was prepared by mixing the aqueous pigment slurry with 2.5 parts by solid weight of oxidized starch (trademark: ACE A, made by OJI CORN STARCH K.K.), 11.5 parts by solid weight of a styrene-butadiene copolymer latex (trademark: T-2550K, made by JSR CO.) and diluting the mixture with water.

Preparation of an undercoated paper sheet

15 **[0111]** The coating color for the undercoat layer was coated on front and back surfaces of the same paper sheet having a basis weight of 54 g/m² as in Example 1 by using a blade coater, and dried, to form front and back undercoat layers each in a dry amount of 6.5 g/m².

Coating the undercoated paper sheet with the coating color for the uppercoat layer

20 **[0112]** The coating color for the uppercoat layer was coated on the front and back surfaces of the undercoated paper sheet by using a blade coater and dried, to form front and back uppercoat layers each having a dry weight of 8 g/m². On each of the front and back surfaces of the paper sheet, a composite coating layer consisting of an undercoat layer formed on the paper sheet and an uppercoat layer formed on the undercoat layer, was formed.

25 **[0113]** The two surface-coated paper sheet was subjected to a smoothing treatment by using a 4 nip-soft calender having metal rolls heated to a surface temperature of 150°C.

[0114] A two surface-coated paper sheet for electro-coagulation printing was obtained.

Comparative Example 7

30 **[0115]** A two surface-coated paper sheet for electro-coagulation printing was produced by the following procedures.

Preparation of a coating color for an undercoat layer

35 **[0116]** An aqueous pigment slurry having a solid content of 72% by weight was prepared by dispersing a mixture of 30 parts by weight of kaolin (trademark: UW-90, made by ENGELHARD CO.), with 70 parts by weight of ground calcium carbonate (trademark: HYDROCURVE 90, made by BIHOKU FUNKAKOGYO K.K.) and 0.2 part of sodium polyacrylate, as a dispersing agent, in water by using a Cowless dissolver.

40 **[0117]** A coating color having a solid content of 65% by weight was prepared by mixing the aqueous pigment slurry with 8 parts by solid weight of oxidized starch (trademark: ACE A, made by OJI CORN STARCH K.K.), 13 parts by solid weight of a styrene-butadiene copolymer latex (trademark: T-2550K, made by JSR CO.) and diluting the mixture with water.

Preparation of a coating color for uppercoat layer

45 **[0118]** An aqueous pigment slurry having a solid content of 66% by weight was prepared by dispersing a mixture of 55 parts by weight of kaolin (trademark: UW-90, made by ENGELHARD CO.), with 10 parts by weight of ground calcium carbonate (trademark: FMT-90, made by FEIMATEC CO.), 20 parts by weight of satin white (trademark: SW-BL, made by SHIRAIISHI KOGYO K.K.) and 15 parts by weight of a plastic pigment (trademark: HP-1055, made by ROHM AND HAAS CO.) and 0.2 part of sodium polyacrylate, as a dispersing agent, in water by using a Cowless dissolver.

50 **[0119]** A coating color having a solid content of 60% by weight was prepared by mixing the aqueous pigment slurry with 1 part by solid weight of oxidized starch (trademark: ACE A, made by OJI CORN STARCH K.K.), 1 part of polyvinyl alcohol (trademark: PVA-105, made by KURARAY K.K.) and 17 parts by solid weight of a styrene-butadiene copolymer latex (trademark: T-2550K, made by JSR CO.) and diluting the mixture with water.

Preparation of an undercoated paper sheet

55 **[0120]** The coating color for the undercoat layer was coated on front and back surfaces of the same paper sheet

having a basis weight of 54 g/m² as in Example 1 by using a blade coater, and dried, to form front and back undercoat layers each in a dry amount of 10 g/m².

Coating the undercoated paper sheet with the coating color for the uppercoat layer

5

[0121] The coating color for the uppercoat layer was coated on the front and back surfaces of the undercoated paper sheet by using a blade coater and dried, to form front and back uppercoat layers each having a dry weight of 15 g/m². On each of the front and back surfaces of the paper sheet, a composite coating layer consisting of an undercoat layer formed on the paper sheet and an uppercoat layer formed on the undercoat layer, was formed.

10

[0122] The two surface-coated paper sheet was subjected to a smoothing treatment by using a 11 nip-super calender having metal rolls heated to a surface temperature of 80°C.

[0123] A two surface-coated paper sheet for electro-coagulation printing was obtained.

TESTS

15

[0124] Each of the coated paper sheets of Examples 1 to 11 and Comparative Examples 1 to 7 was air-conditioned under the conditions in accordance with Japanese Industrial Standard (JIS) P 8111 for 6 hours, and subjected to printing by an electro-coagulation printer.

[0125] The coated paper sheets or the printed coated paper sheet were subjected to the following tests.

20

(1) Total pore volume and pore size of coated paper sheets

25

[0126] A specimen of the coated paper sheet was subjected to a mercury porosimeter (Model: PMI 30000 psi, made by PMI CO.) by which the average pore size and a total pore volume of the specimen were determined by a mercury press-penetration method. The total pore volume is a total volume of the pores having a pore size of 0.01 to 0.40 μm.

(2) Smoothness of coated paper sheet

30

[0127] The smoothness of a specimen was measured by a microtopograph (press-reflection smoothness tester) made by TOYO SEIKI K.K. under a pressure of 3,922,660 Pa (40 kgf/cm²).

(3) Gloss of coated paper sheet

35

[0128] The gloss was measured in accordance with Japanese Industrial Standard (JIS) P 8142.

(4) Evaluation of printing property of coated paper sheet

40

[0129] A specimen was printed in a low color density region and a high color density region of a single color by an electro-coagulation printer (made by ELCORSY CO.). The printed ink images were evaluated by the naked eye. The ink used for printing comprised water as a medium, a polymeric binder and a coloring pigment.

Evaluation of ink-transfer property in a low color density region

45

[0130]

4: Coagulation ink images are smoothly and uniformly transferred without forming no ink-transferred portion. The printed ink images have a high color density and a high uniformity.

3: Coagulated ink images are smoothly transferred and uniformly absorbed.

50

2: No ink-transferred portions are formed and uneven ink image absorption occurs.

1: Uneven ink image absorption occurs and ink-transfer property is bad.

Evaluation of ink transfer property in a high color density region

55

[0131]

4: Printed ink images have a high color density and ink transfer property is good.

3: Ink transfer property is good. Color density of printed ink image is slightly low.

- 2: Ink absorption and ink image transfer are slightly uneven.
- 1: Ink absorption is certainly uneven and ink image transfer property is bad.

[0132] The test results are shown in Table 1.

Table 1

Item	Total pore volume	Coated paper sheet		Ink transfer property		Water resistance	
		Press-reflection smoothness	Gloss of coated paper sheet	Low color density region	High color density region		
Example No.	(ml/g)	(μm)	(%)				
Example	1	0.11	0.6	40	3	3	3
	2	0.13	0.5	75	3	4	3
	3	0.12	0.5	65	3	3	3
	4	0.15	0.6	70	4	4	3
	5	0.14	0.6	60	4	4	3
	6	0.13	0.7	50	4	3	3
	7	0.11	0.8	55	4	3	3
	8	0.12	0.4	72	4	4	3
	9	0.12	0.06	88	4	3	3
	10	0.13	0.05	87	4	3	3
	11	0.11	0.6	40	3	3	4
Compa-rative Example	1	0.05	0.5	75	2	1	1
	2	0.09	0.8	70	3	2	2
	3	0.07	0.6	65	2	2	3
	4	0.05	0.4	70	3	1	1
	5	0.22	2.8	40	2	2	3
	6	0.065	0.6	75	2	1	1
	7	0.05	0.4	83	2	1	1

[0133] Table 1 shows that the coated paper sheets of the present invention are useful for electro-coagulation (elcography) printing in which an ink capable of being gelled in an electrically changed condition, is gelled imagewise on an electrode consisting of a metal cylinder, and the gelled ink images are transferred to a recording surface of the recording sheet. When the coated paper sheet is used for the electro-coagulation printing, ink images with a high quality are recorded thereon.

Claims

1. A coated paper sheet for use of electro-coagulation printing comprising a support paper sheet and at least one coating layer formed on the support paper sheet and comprising a pigment and a binder, the coated paper sheet having a total pore volume of fine pores having a pore size of 0.01 to 0.40 μm , of 0.10 to 0.20 ml/g, determined by a mercury porosimeter.
2. The coated paper sheet for electro-coagulation printing as claimed in claim 1, wherein the coated surface of the coated paper sheet has a smoothness of 1.0 μm or less determined by a microtopograph under a pressure of 3,922,660 Pa (40 kgf/cm²).
3. The coated paper sheet for electro-coagulation printing as claimed in claim 1, or 2, wherein the pigment includes at least one member selected from the group consisting of calcinated clay, structured kaolin and delaminated clay in an amount of 20 to 70% by weight, based on the total weight of the pigment in the coating layer.
4. The coated paper sheet for electro-coagulation printing as claimed in claim 1 or 2, wherein the coated surface of the coated paper sheet has a gloss of 70% or more, determined in accordance with Japanese Industrial Standard

P 8142.

5. The coated paper sheet for electro-coagulation printing as claimed in claim 4, wherein the coated paper sheet having a gloss of 70% or more is one formed by a cast-coating method.

5

10

15

20

25

30

35

40

45

50

55

Fig.1

