

12 **EUROPEAN PATENT APPLICATION**
published in accordance with Art. 158(3) EPC

21 Application number: **88900801.7**

51 Int. Cl.³: **H 01 B 5/14**
H 01 B 7/08, G 09 F 13/00

22 Date of filing: **12.01.88**

Data of the international application taken as a basis:

86 International application number:
PCT/JP88/00024

87 International publication number:
WO88/05206 (14.07.88 88/15)

30 Priority: **12.01.87 JP 5585/87**
12.09.87 JP 228947/87

43 Date of publication of application:
08.03.89 Bulletin 89/10

84 Designated Contracting States:
BE DE FR GB IT NL

71 Applicant: **SEKISUI KAGAKU KOGYO KABUSHIKI**
KAISHA
4-4 Nishitenma 2-chome Kita-ku
Osaka-shi Osaka 530(JP)

72 Inventor: **HASHIKAWA, Takaaki**
14-11, Kotobuki 1-chome
Taito-ku Tokyo 111(JP)

74 Representative: **Dipl.-Ing. Schwabe, Dr. Dr. Sandmair, Dr.**
Marx
Stuntzstrasse 16
D-8000 München 80(DE)

54 **ELECTRICALLY CONDUCTIVE TRANSPARENT MATERIAL AND A DISPLAY DEVICE USING THE ELECTRICALLY CONDUCTIVE MATERIAL.**

57 An electrically conductive transparent material that is preferably used as a feeding means, and a display device which employs the electrically conductive transparent material. The electrically conductive transparent material is comprised of a substrate unit made of an electrically insulating transparent material and an electrically conductive transparent unit buried in the substrate unit. The electrically conductive transparent unit is provided in the form of a plurality of layers maintaining a predetermined distance in the substrate unit. Another electrically conductive transparent material is comprised of a substrate unit made of an electrically insulating transparent material and an electrically conductive transparent unit buried in the substrate unit. The electrically conductive transparent unit consists of a plurality of electrically conductive wires that do not intersect with each other. The display device comprises the electrically conductive transparent material and display elements whose feeder terminals are connected to a plurality of transparent conductive portions provided in the electrically conductive transparent material.

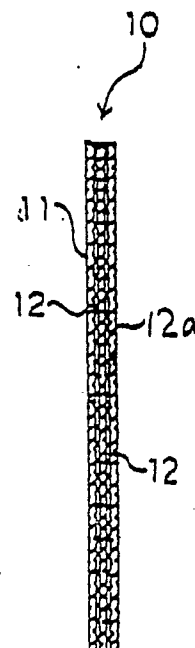

TITLE OF THE INVENTION

5 An electrically conductive transparent material and a display device using the electrically conductive transparent material

TECHNICAL FIELD

10 This invention relates to an electrically conductive transparent material that is suitable for use as a feeding means for the supply of electricity and to a display device using the said electrically conductive transparent material. The electrically
15 a feeding means for various kinds of display devices such as information display boards, billboards, and the like.

BACKGROUND ART

20 Generally, display devices comprising display elements such as illuminants or the like are constructed by the attachment of the display elements on a support that is not transparent. However, because the
25 said support is not transparent, when the display device is being looked at, it can be seen that the display elements are held on the support. Thus, conventional display devices have poor display effects offered to the viewer. Also, depending on the direction
30 tion in which the viewer is looking at the display device, the light emitted from the display elements may be obstructed by the support, in which case it may not be possible to see the display device clearly.

- 2 -

For these reasons, one possible solution is to form the support from a transparent material made of transparent resin or the like. When a display device
5 constructed by the attachment of display elements to this kind of a transparent support is being looked at, the said display elements look as if they are floating in the air. For that reason, the display effects are improved, and the light emitted from the display
10 elements is not obstructed by the support. However, if the support is made of a transparent material as is described above, there are the following defects.

There are feeding wires to supply electricity
15 to the display elements that are attached to the support, which wires are disposed along the surface of the support, so the said feeding wires can be seen from the outside. Thus, when the display device is being looked at from its outside, the feeding wires can also
20 be seen, and the appearance of the display device is damaged. It is necessary to attach the said wires to the support so that they will not move, which lowers productivity. When a plurality of display devices are to be attached to the support, this tendency is even
25 more marked.

A feeding means that looks transparent has not yet been suggested. There has been suggested an electrically conductive transparent material that is
30 not a feeding means, but this is used as a means to prevent static electricity. This electrically conductive transparent material is made up of one layer of conductive mesh made of very thin strands, which con-

ductive mesh is buried in a base made of an electrical-
ly insulating transparent material. Or, the electri-
cally conductive transparent material is formed with
the provision of a transparent conductive layer on the
5 surface of the base.

However, because the electrically conductive
transparent material that is used as a means to prevent
static electricity is made up of one layer of a
10 conductive mesh buried in a base, the electrically con-
ductive transparent material cannot have its conductive
mesh divided into two or more portions (positive and
negative portions) electrically. Thus, it is not
possible for conventional electrically conductive
15 transparent materials to be used as a feeding means for
the supply of electricity to both the positive and
negative terminals of display elements, lighting equip-
ments, or the like.

20 DISCLOSURE OF THE INVENTION

This invention solves the above-mentioned
problems, and makes possible the objectives of
providing an electrically conductive transparent
25 material that is suitable for use as a feeding means
that is transparent in appearance; and providing a
display device comprising display elements that are not
obstructed by the feeding means, with excellent display
effects offered to the viewer, because the display
30 elements look as if they were floating in the air when
viewed from the outside.

Summary of the invention

The electrically conductive transparent material of this invention comprises a substrate unit made of an electrically insulating transparent material, and
5 an electrically conductive transparent unit buried in the said substrate unit, the said electrically conductive transparent unit being provided in the form of a plurality of layers at fixed intervals within the said substrate units, thereby attaining the above-mentioned
10 objectives. The said electrically conductive transparent unit can be formed from an electrically conductive mesh. This electrically conductive mesh is preferably formed of electrically conductive wires with a diameter of 0.1 mm or less. The said electrically
15 conductive transparent unit can also be formed of a metal foil with a number of small pores.

Another electrically conductive transparent material of this invention comprises a substrate unit
20 made of an electrically insulating transparent material, and an electrically conductive transparent unit buried in the said substrate unit, the said electrically conductive transparent unit consisting of a plurality of electrically conductive wires that do not
25 intersect with each other, thereby attaining the above-mentioned objectives. The said electrically conductive wires preferably have individual diameters of 0.1 mm or less. The said electrically conductive transparent unit can also be formed from a plurality of electrically
30 conductive wires that are arranged approximately in parallel and from electrically insulating wires that are contained in the network of the said plurality of electrically conductive wires, as the fabricating

material. It is preferable for the diameters of the electrically conductive wire and the electrically insulating wire to be 0.1 mm or less.

5 In the substrate unit that is provided for the electrically conductive transparent materials mentioned above, there can be provided a number of holes for the exposure of transparent conductive portions of the electrically conductive transparent
10 unit. Also, the substrate unit can be formed by the attachment of a plurality of constituent substrates together by an adhesive, and the electrically conductive transparent unit can be arranged in the attached parts of the said constituent substrates. The
15 electrically conductive transparent unit can be positioned from the central part in the direction of thickness of the substrate unit toward one surface of the substrate unit.

20 The electrically conductive transparent unit is comprised of transparent conductive portions made of a conductive mesh, metal foil with a number of pores, a number of electrically conductive wires, or the like, so an electrically conductive transparent material that
25 has these transparent conductive portions looks transparent. The transparent conductive portions provided within the substrate unit can be insulated by use of the insulating substrate portion, so it is possible to divide the transparent conductive portions electrically
30 into two or more portions (positive and negative portions). The electrically conductive transparent unit is provided within the substrate unit, so there is no possibility of a person coming into contact with the

electrically conductive transparent unit from the outside to get an electric shock. When the electrically conductive transparent material is being transported or processed in manufacturing, there is no possibility of its peeling or of its damage from the contact of the electrically conductive transparent unit with outside objects. The electrically conductive transparent unit is buried in the substrate unit, so there is no exposure of the electrically conductive transparent unit to the outside of the substrate unit. Thus, there is no danger of corrosion of the electrically conductive transparent unit because of contact with the outside air or of contamination by means of particles in the air or the like.

15

In particular, as the electrically conductive transparent unit consists of a plurality of electrically conductive wires that do not intersect with each other, and electrically insulating wires as the fabricating material, it is possible to bury the electrically conductive wires readily in the substrate unit at fixed intervals with accuracy. Also, the electrically conductive transparent material is installed over almost the entire surface of the substrate unit, so it is possible to expose the transparent conductive portions at any part of the substrate unit.

20
25

In this way, according to the electrically conductive transparent material of this invention, it is possible to provide the inside of the substrate unit with a plurality of transparent conductive portions that are electrically insulated. Therefore, it is possible to supply electricity to surface elements,

30

lighting equipments, and the like by the connection of both positive and negative terminals of the surface elements, lighting equipment, and the like with the different transparent conductive portions in the center region or in the edge regions of the transparent substrate unit. Also, the electrically conductive transparent material of this invention is transparent and can be used as a safe and stable feeding means. This electrically conductive transparent material can be used as a transparent feeding means without scattering of the conductive portions, which can be used for an display device and the like.

The display device of this invention is provided with the above-mentioned electrically conductive transparent material and display elements that are each connected to feeder terminals for a plurality of transparent conductive portions provided for the said electrically conductive transparent material, thereby attaining the above-mentioned objectives. Openings are formed in the substrate unit of the electrically conductive transparent material, and the display elements are placed in the openings, so that the feeder terminals of the display elements can be connected electrically with the transparent conductive portions. Also, around the said openings, it is possible to position a plurality of the said display elements. In addition, the substrate unit is provided with concave portions for exposure of the transparent conductive portions, and the display elements are placed in the concave portions; the display elements may be connected electrically with the transparent conductive portions. It is also possible for a plurality of the display

elements that are arranged along the outside of the substrate unit to be connected electrically with the transparent conductive portions that are exposed on the outer edge surface of the substrate unit.

5

In the display device of this invention, feeding wires to supply electricity to the display elements are constructed of transparent conductive portions that are internalized in the transparent substrate unit. Thus, the display elements can operate in the inner section or outer section of the transparent space provided in the substrate unit, so that there cannot be seen intricate feeding wires in the said inner transparent space. As the transparent conductive portions that support the display elements are transparent, the display elements seem to be floating in the air when the display device is being viewed. Thus, the viewer is given an unexpected impression, and the display effects are enhanced; also, because the display elements are not obscured by their support, it is possible to view the display of the display elements from any direction around the display device.

25

BEST MODE FOR CARRYING OUT THE INVENTION

Example 1

As shown in Figures 1 and 2, an electrically conductive transparent material 10 is comprised of a substrate unit 11 made of an electrically insulating transparent material and an electrically conductive transparent unit consisting of a plurality of transparent conductive portions 12 and 12 buried in the said

30

substrate unit 11 so as to be electrically insulated from each other.

5 The substrate unit 11 is made of an electrically insulating transparent material (such as resin, glass, and the like) that is uncolored or colored. The electrically conductive transparent unit 12 is provided in the form of a conductive mesh of electrically conductive wires 12a that are arranged in
10 a network. The said networks of conductive mesh 12 are arranged so as to make a plurality of layers inside the substrate unit 11 at fixed intervals. Because there is substrate material that has electrically insulating properties between the two conductive meshes 12 and 12,
15 the conductive meshes 12 and 12 are both insulated electrically by the substrate material.

The cross-sectional shape of the electrically conductive wires 12a that form the conductive meshes 12
20 can be either circular or square. It is preferable that the diameter or width of the electrically conductive wires 12a be 0.1 mm or less. The spacing between two adjacent electrically conductive wires 12a and 12a can be set so that when a person is viewing the electrically conductive transparent material 10 from a
25 direction that is approximately at right angles with respect to the outer surface of the electrically conductive transparent material 10, the transparent mesh 12 cannot be seen clearly. For example, when the strands of the conductive mesh 12 are electrically
30 conductive wires 12a with a diameter of about 0.1 mm, the spacing between the adjacent electrically conductive wires 12a and 12a can be set at about 10 mm

or more. When electrically conductive wires 12a with a diameter of about $20\ \mu\text{m}$ are used as strands for the conductive mesh 12, the spacing between the adjacent electrically conductive wires 12a and 12a can be set at about 1 mm. As such electrically conductive wires 12a, there can be used metal strands such as gold wires, silver wires, copper wires, zinc wires, stainless steel wires, etc., or strands made of resin such as polyester wires, nylon wires, etc., the outer surface of which is covered with metal by vapor deposition, metal plating, or the like.

The electrically conductive transparent material 10, as shown in Figure 3, can be formed integrally by the laminating together of two transparent plates 11A and 11B that are made of an electrically insulating transparent material, in which only one layer of the conductive mesh 12 mentioned above is buried. When two conductive meshes 12 and 12 are disposed so as to form parallel layers, that is, when the conductive mesh 12 of Figure 4A is overlaid by the conductive mesh 12 of Figure 4B, and the directionality of the electrically conductive wires 12a of the said two conductive meshes 12 is the same or almost the same, a moire phenomenon occurs, and the transparency of the electrically conductive transparent material 10 is decreased; at the same time, the appearance is intricate, which is not appropriate. Therefore, when the electrically conductive transparent material 10 is manufactured, it is preferred that the conductive mesh 12 of Figure 4A is overlaid by the conductive mesh 12 of Figure 4C so that the directionalities of the electrically conductive wires 12a and 12a of the

said two conductive meshes 12 and 12 are at 45° with respect to each other.

5 A display device 1 using an electrically conductive transparent material 10 constructed in this way is made as follows.

10 As shown in Figures 5 to 7, the display device 1 is provided with the electrically conductive transparent material 10, a foot section 7 that supports the electrically conductive transparent material 10 in a vertical portion, and light bulbs 13 as one example of display elements that are connected to their feeder terminals on the conductive mesh 12 of the electrically
15 conductive transparent material 10.

At the bottom edge of the electrically conductive transparent material 10, a pair of conductive meshes 12 and 12 that have their electrically
20 conductive wires 12a and 12a exposed are connected to a cord 5, the said cord 5 being connectable to an electrical power source by means of a plug 6 that is attached to the end of the cord 5. There is an arrow-shaped opening 17 in the electrically conductive
25 transparent material 10, formed by the cutting out of a portion of the said electrically conductive transparent material 10. Around the edges of this opening 17, there are a plurality of ends of the above-mentioned electrically conductive wires 12a that are buried in
30 the electrically conductive transparent material 10. A number of light bulbs 13 are fixed in place along the edges of the opening 17, and the feeder terminals (positive and negative terminals) of the said light

bulbs 13 are connected to the exposed portions (positive portions) of electrically conductive wires 12a that are exposed as mentioned above.

5 Figure 7 is a schematic diagram showing the electrical circuit of the display device 1. In this figure, the electrical source is represented by reference numeral 8, and the switch is represented by reference numeral 9.

10 With the display device 1 mentioned above, if the light bulbs 13 around the edges of the opening 17 formed in the electrically conductive transparent material 10 are lighted, the said light bulbs seem to
15 be floating in the air when this electrically conductive transparent material 10 is viewed. Also, the existence of the feeding wires 12 to supply electricity to the light bulbs 13 cannot be seen from its surroundings, resulting in an uncluttered appearance for the display device 1.
20

 Also, in the practice of this invention, the electrically conductive transparent unit 12 that is internalized in the substrate unit 11 can be formed
25 from parallel wires made of 2 or more extremely thin strands or else from conductive films of vapor-deposited SiO₂-indium alloy. Display elements 13 can be, in addition to light bulbs, fluorescent lights, neon tubes, light-emitting diodes, microminiature
30 lamps, electroluminescent panels, plasma display panel lamps, and other illuminants. In addition, in this example, as objects to which electrically conductive wires 12a of electrically conductive transparent

material 10 can supply electricity, there are liquid-crystal display panels, display panels using electrochromic display lights, magnetic fluids for which the magnetic properties can be changed electrically, and sound display devices such as speakers.

Example 2

Figure 8 and Figure 9 show other examples of electrically conductive transparent materials 20. In this electrically conductive transparent material 20, three conductive portions 22A, 22B, and 22C are buried together at certain intervals in the substrate unit 21 so as to form parallel layers. When this electrically conductive transparent material 20 is used to construct a display device 2, transparent conductive portions 22A, 22B, and 22C are exposed on the outer surfaces of the edges of electrically conductive transparent material 20 or on the edges of an opening in electrically conductive transparent material 20 that are connected to the feeder terminals of the light bulbs 23 (23A and 23B). The transparent conductive portion 22C shown in Figure 9 functions as the common wire. The reference numeral 8 in the figure is the power source, and the reference numerals 9A and 9B are switches. With this display device, the switching on and off the light bulbs 23A and 23B can be controlled independently, and it is possible to bring about a change in the display condition. Moreover, the transparent conductive portions 22 internalized in the base 21 can be multilayered, with four or more layers. With this display device 2, it is possible to supply electricity to the light bulbs 23A and 23B independently, so as to have a complex pattern of lighting; if a

number of light bulbs 23 are connected, it is possible, for example, to turn on the light bulbs in order from the first light bulb 23 to the last light bulb 23, followed by turning on all of the light bulbs 23 at the same time, and to repeat this procedure.

Example 3

Figure 10 and Figure 11 shown another example of the electrically conductive transparent material 30 of this invention. The said electrically conductive transparent material 30 has electrical insulation constructed in the same way as the substrate unit of Example 1; it also has three transparent plates 31A, 31B, and 31C (substrate unit 31) and transparent conductive portions 32 that are inserted in the spaces between the transparent plates 31A, 31B, and 31C.

The electrically conductive transparent unit 32 is provided in the form of a metal foil with a number of small pores therein, and the said metal foils 32 are positioned so as to be inserted in the spaces between the transparent plates 31A, 31B, and 31C. Thus, two sheets of metal foil 32 constitute the layers that are insulated electrically with the transparent plate 31B interposed therebetween. The three transparent plates 31A, 31B, and 31C can be made of the same material or of different materials.

The electrically conductive transparent material 30 can be made as shown in either 1 or 2 below.

1. On the surface of the transparent plate 31A made of synthetic resin, the above-mentioned metal foil 32 with a number of pores, a transparent plate 31B made of synthetic resin, and another metal foil 32, on which there is transparent plate 31C made of synthetic resin, are arranged in layers, in this order. Next, this layered structure is heated, and also pressed from above and below, so as to make the layered structure into one piece by fusion of the resin.

2. On the surface of transparent plate 31A made of synthetic resin, the above-mentioned metal foil 32, a transparent plate 31B made of synthetic resin, another metal foil 32, and a transparent plate 31C made of synthetic resin are arranged in layers, in this order. Also, into the spaces between the metal foils 32 and 32 and the transparent plates 31A, 31B, and 31C, there is introduced a transparent adhesive agent. Next, the adhesive agent is allowed to harden, which makes the layered structure into one piece.

In Figures 12 to 17, various kinds of metal foils 32 that are used in this example are shown. The small pores provided in the metal foil 32, for example, are opened by use of the photolithographic method so as to be a fixed shape by being etched, or they can be opened by use of a mechanical means so as to be of a fixed shape by being punched, but the method to be used is not limited thereto, and any means that can give a number of small pores of a fixed shape can be used. There is no special restriction as to the shape of the

small pores. Also, the material used for the metal foil can be copper, iron, stainless steel, aluminium, or other materials that can be formed into a foil.

5 It is preferable for the thickness of the
said metal foil 32 to be 30 μm or less, and for the
width of the wire to be 30 μm or less; the permeability
of the metal foil 32 to light should be 70% or more.
If the thickness of the metal foil 32 is 30 μm or more,
10 if the width of the wire is 30 μm or more, or if the
permeability of the metal foil 32 to light is 70% or
less, the transparency of the electrically conductive
transparent material 30 that is made therewith will be
decreased. Then, in a display device 3 that is
15 constructed by the installation of display elements 33
on both sides of such an electrically conductive
transparent material 30, when the display elements 33
on both sides are observed from one side, the clearness
of the display of the display elements 33 on the other
20 side is decreased.

Also, as is shown in Figure 18, it is possible to form attached holes 35 for a number of display elements 33 in the substrate unit 31, which
25 attached holes 35 extend to both metal foils 32 and 32.
Attached holes 35 can also be formed where the display
elements 33 of the electrically conductive transparent
material 30 are to be inserted. In this example, the
light bulbs 33A to 33H are arranged so as to light up
30 in order, making an arrow that indicates an entrance.

In addition, as shown in Figures 19 to 21, if a number of attached holes 35 are formed in a variety

of patterns in the substrate unit 31, the display elements 33 can be simply inserted in the required positions, which is convenient when changing the design of the electrically conductive transparent material 30
5 by alternation of the places in which the display elements are installed. That is, by the formation in substrate unit 31 of attached holes 35 in which the display elements 33 can be placed or from which they can be removed, the pattern, lettering, color, etc., of
10 the electrically conductive transparent material 30 can be changed at will.

Figure 22 shows another example of the electrically conductive transparent material 30A of
15 this invention. The electrically conductive transparent material 30A is different from the electrically conductive transparent material 30 mentioned above in that the three layers of metal foils 32A, 32B, and 32C, are buried therein. As shown in Figures 23 to 25, the
20 metal foils 31A, 31B, and 31C are exposed at the surfaces of the outer part of the electrically conductive transparent material 30 or at the attached holes 35, and the exposed portions of the metal foils 31A, 31B, and 31C can be connected with the
25 feeder terminals of light bulbs 33A and 33B. Metal foil 32C functions as the common wire. Reference numeral 8 in the figure is the power source and reference numerals 9A and 9B are the switches. In the
30 display device 3 with this electrical circuit, the turning on and off of the light bulbs 33A and 33B can be controlled independently, so it is possible to bring about a change in the display condition.

Figure 24 is an partially enlarged plan view of an electrically conductive transparent material 30 in which attached holes 35 for display elements are opened over the entire surface, and light-emitting diodes 33C are installed so as to form a pattern of the letters A and B. In Figure 24, the positive terminals (shown in the figure as black dots) of the light-emitting diodes 33C (which correspond to the 33A of the electrical circuit shown in Figure 23) that are arranged in the pattern of a letter A are connected to the metal foil 32A, and the negative terminals (shown in the figure as white dots) are connected to the metal foil 32C; the positive terminals (shown in the figure as black dots) of the light-emitting diodes 33D (which correspond to the 33B of the electrical circuit of Figure 23) that are arranged in the pattern of a letter B are connected to the metal foil 33B, and the negative terminals (shown in the figure as white dots) are connected to the metal foil 33C. By the control of the opening and closing of the switches 9A and 9B, it is possible to illuminate only the letter A, only the letter B, or both the letters A and B at the same time.

Figure 25 is a perspective view showing one example of a display device 3 employing the principles shown in Figures 23 and 24 above. The white dots show an illuminated light, and the black dots show a light that is not illuminated. For example, during business hours, the display elements 33 that are arranged in a pattern that spells out the word "OPEN" can be illuminated, and after business hours, the display elements 33 that are arranged in a pattern that spells out the word "CLOSED" can be illuminated, while the

display elements 33 that are arranged in the pattern that spells out the word "OPEN" are turned off.

5 Also, in this example, it is possible to have a plurality of layers of metal foil 32 numbering 4 layers or more internalized in the substrate unit 31. It is not necessary to arrange the metal foils 32 at the center part in the direction of thickness of the substrate unit 31; it is possible to have a layer
10 extending from the central position in the direction of thickness toward one surface. The kinds of display elements 33 listed in Example 1 above are all suitable for use in this example, as well.

15 Example 4

Figures 26 and 27 show another electrically conductive transparent material 40 of this invention.

20 In this example, the electrically conductive transparent material 40 comprises a pair of transparent plates 41A and 41B (substrate unit 41) that form a plate (the constituent substrate) made of an electrically insulating transparent material of synthetic resin, glass sheets, or the like, and a conductive
25 mesh 42 installed between the two transparent plates 41A and 41B. The transparent plates 40A and 40B can be made of the same material or of different materials.

30 The conductive mesh 42 is constructed, as shown in Figures 28 to 36, of a network in which a plurality of mutually parallel electrically conductive wires 42a are combined with electrically insulating

wires 42b as the fabricating material. The material that is used for the electrically conductive wires 42a and the spacings between the adjacent electrically conductive wires 42a and 42a can be the same as described in Example 1 above. The electrically conductive wires 42a are formed from very fine strands with a diameter or a width of 0.1 mm or less. As the electrically insulating wires 42b, there can be used strands made of resin such as polyester wires, nylon wires, etc. In an electrically conductive transparent material 40 constructed in this way, electrically conductive wires 42a and electrically insulating wires 42b that constitute a conductive mesh 42 are made of very fine strands, so the entire structure is transparent, and may be either colorless or colored. Also, the electrically conductive transparent material 40 has buried in the substrate unit 41 a conductive mesh 42 that has electrically insulating wires 42b as the fabricating material, so it is possible to establish and maintain the fixed spacing of the electrically conductive wires 42a with accuracy and ease.

The electrically conductive transparent material 40 has a conductive mesh 42 buried at about the center part in the direction of thickness of the substrate unit 41, so that the transparent plate 41A or 41B can be removed in parts, and the adhesive layer can be removed by use of a solvent, so as to expose portions of the electrically conductive wires 42a of the conductive mesh 42, so that they can be used as terminals for the supply of electricity.

Also, the combined condition of the electrically insulating wires 42b with the electrically conductive wires 42a has a plurality of possibilities, as is shown in Figures 28 to 36.

5

The electrically conductive transparent material 40 can be manufactured by the methods numbered 1 to 3 below.

10

1. On top of a transparent plate 41A, a conductive mesh 42 is placed. Next, on top of the transparent plate 41A and the conductive mesh 42, an adhesive layer is formed by the application of a transparent adhesive agent in liquid form or by the attachment of a transparent adhesive agent in sheet form. Thereafter, while the said adhesive layer is not yet hardened, another transparent plate 41B is placed on top of the adhesive layer and fixed by the application of pressure.

15

20

2. On top of a transparent plate 41A, a conductive mesh 42 is placed. Next, on top of the transparent plate 41A and the conductive mesh 42, an adhesive layer is formed by the application of a transparent adhesive agent in liquid form or by the attachment of a transparent adhesive agent in sheet form, and the said adhesive layer is allowed to harden. After the adhesive layer has hardened, an electrically insulating transparent material in liquid form is poured (or sprayed) on top of the adhesive layer and allowed to harden, which electrically insulating transparent material forms a transparent plate 41B when it has hardened.

25

30

3. On top of a transparent plate 41A, a conductive mesh 42 is placed. Next, the transparent plate 41A is softened by the application of heat, and at the same time, the conductive mesh 42 is pressed into the surface of the transparent plate 41A by the application of pressure, by which means the conductive mesh 42 is attached to the transparent plate 41A. Thereafter, in the same way as is described above, a transparent plate 41B is formed on top of the said adhesive layer in liquid form or sheet form.

Example 5

A different form of Example 4 is shown in Figure 37.

In this example, a substrate unit 51 is formed from a transparent plate 51A made of an electrically insulating transparent material, and an adhesive layer 51B. An electrically conductive transparent material 50 is comprised of a conductive mesh 52 placed toward one surface of the said transparent plate 51A, and an adhesive layer 51B to attach the said conductive mesh 52 onto the transparent plate 51A. The adhesive layer 51B is formed from a thin film that is thinner than the transparent plate 51A, being for example, a thin film with the thickness of 2 mm or less, so the conductive mesh 52 can be positioned off-center toward the surface of the electrically conductive transparent material 50. By the dissolving of this adhesive layer 51B by use of a solvent, it is possible to obtain the terminals readily for the supply of electricity. Also, by the dissolving

of one part of the transparent plate 51A that constitutes the substrate unit 51, it is possible to expose one part of the electrically conductive wires 52 that are internalized within the substrate unit 51, and therefore to use them as terminals for the supply of electricity.

Example 6

Another different form of Example 4 is shown in Figure 38.

The electrically conductive transparent material 60 has a substrate unit 61 that can be melted by the application of heat, and a conductive mesh 62 that is half-buried in the surface of the said substrate unit 61 by the use of heat-fusion. Although one part of the conductive mesh 62 is exposed on the surface of substrate unit 61, there is no problem when a small electrical current that has no effect on the human body flows through the conductive mesh 62. When a large electrical current that can cause an electric shock to the human body flows through the conductive mesh 62, the surface of the conductive mesh 62 must be covered with an electrically insulating transparent material after the feeder terminals are connected to the conductive mesh 62. Two pieces of electrically conductive transparent material 60 constructed in this ways are arranged so that the exposed portions of their conductive meshes 62 face each other, and the resulting structure can be used as a touch panel as well. Also, before the adhesive layer applied on the surface of the substrate unit 61 has hardened, the conductive mesh 62 is buried in the said adhesive layer so as to be half-

buried and half-exposed at the surface of the substrate unit 61, and then the adhesive layer can be allowed to harden. Also, when the substrate unit 61 made of synthetic resin is formed, it is possible to bury a part of the conductive mesh 62 inside the said substrate unit 61, providing an electrically conductive transparent material 60.

Example 7

Yet another example is shown in Figures 39 to 41. This electrically conductive transparent material 70 is comprised of, as transparent conductive portions, a plurality of electrically conductive wires 72 that are lined up inside a plate-shaped substrate unit 71 so as to be approximately parallel to each other.

The substrate unit 71 has a pair of transparent plates 71A and 71B made of an electrically insulating transparent material, and an adhesive layer 79 that connects the two transparent plates 71A and 71B to each other. The electrically conductive transparent material 70 can be manufactured in the same way as in Example 4 above. This electrically conductive transparent material 70 has internalized therein a plurality of electrically conductive wires 72 that are lined up so as to be approximately parallel to each other, so it is possible to separate the electrically conductive wires 72 into two or more regions electrically, and in addition, the same effects as for the above examples can be obtained.

Example 8

A different form of Example 7 is shown in Figures 42 to 46.

5 The electrically conductive transparent material 80 shown in Figure 42 is comprised of a substrate unit 81 made of an electrically insulating transparent material, and a plurality of electrically
10 conductive wires 82. The substrate unit 71 has a pair of transparent plates 81A and 81B made of an electrically insulating transparent material, and an adhesive layer 89 that connects the two transparent plates 81A and 81B to each other. This electrically
15 conductive transparent material 80 can be manufactured as follows.

 1. On top of a transparent plate 81A, an adhesive layer 89 is formed by the application of a transparent adhesive agent in liquid form or by the
20 attachment of a transparent adhesive agent in sheet form. A plurality of electrically conductive wires 82 are arranged in parallel on top of the said adhesive layer 89. Next, on top of the said electrically
25 conductive wires 82, a thicker adhesive layer 89 is formed by the application of a transparent adhesive agent in liquid form or by the attachment of a transparent adhesive agent in sheet form. Subsequently, while the adhesive layer 89 is not yet hardened,
30 another transparent plate 81B is placed on top of the said adhesive layer 89 and fixed by the application of pressure. Thereafter, the said adhesive layer 9 is allowed to harden.

2. On top of a transparent plate 81A, an adhesive layer 89 is formed by the application of a transparent adhesive agent in liquid form or by the attachment of a transparent adhesive agent in sheet form. On top of the said adhesive layer 89, a plurality of electrically conductive wires 82 are arranged in parallel. Next, on top of the said electrically conductive wires 82, a thicker adhesive layer 89 is formed by the application of a transparent adhesive agent in liquid form or by the attachment of a transparent adhesive agent in sheet form, and then the said adhesive layer 79 is allowed to harden. After the said adhesive layer 89 has hardened, an electrically insulating transparent material in liquid form is poured (or sprayed) on top of the adhesive layer 89 and allowed to harden, which electrically insulating transparent material forms a transparent plate 81B when it has hardened.

20 Example 9

An electrically conductive transparent material 90 of this invention can also be manufactured as is shown in Figure 43.

25 1. On top of a transparent plate 91A, a plurality of electrically conductive wires 92 are applied with heat and pressure so as to bury them half-way. Next, on top of the transparent plate 91A and the electrically conductive wires 92, an adhesive layer 99 is formed by the application of a transparent adhesive agent in liquid form or by the attachment of a transparent adhesive agent in sheet form. When this adhesive layer 99 has not hardened, another transparent

30

plate 91B is placed on top of the adhesive layer 99 and fixed by the application of pressure.

5 2. On top of a transparent plate 91A, an adhesive layer 99 is formed by the application of a transparent adhesive agent in liquid form or by the attachment of a transparent adhesive agent in sheet form. On top of the said adhesive layer 99, a plurality of electrically conductive wires 92 are
10 arranged in parallel. Next, on top of the said electrically conductive wires 92, a thicker adhesive layer 99 is formed by the application of a transparent adhesive agent in liquid form or by the attachment of a transparent adhesive agent in sheet form. Thereafter,
15 the adhesive layer 99 is allowed to harden. When the adhesive layer 99 has hardened, an electrically insulating transparent material in liquid form is poured (or sprayed) on top of the adhesive layer 99 and allowed to harden, which electrical insulating
20 transparent material forms a transparent plate 91B when it has hardened.

The electrically conductive transparent materials 70 to 90 in the transparent-plate shapes that
25 are constructed as described above have a pair of transparent plates 71 to 91 (substrate unit) made of an electrically insulating transparent material, transparent adhesive layers 79 to 99 that connect the transparent plates 71 to 91, and electrically
30 conductive wires 72 to 92 buried within the adhesive layers 79 to 99. Therefore, by the separation of the transparent plates 71 to 91 from each other in parts, and by the dissolving of the adhesive layers 79 to 99

by use of a solvent, it is possible to expose portions of the electrically conductive wires 72 to 92 to the outside of the bases 71 to 91. The exposed portions of the electrically conductive wires 72 to 92 can be used
5 as terminals for the supply of electricity. As the adhesive layer 79, there can be used adhesive agents that are dissolved by use of solvents such as paint thinner, acetone, xylene, methylethyl ketone, and the like.

10

Example 10

Figures 44 to 46 show another different form of Example 7.

15

The electrically conductive transparent material 100 shown in Figure 44 is made in the following way. On top of a transparent plate 101A, a plurality of electrically conductive wires 102 are arranged roughly in parallel, and then, on top of the
20 transparent plate 101A and the electrically conductive wires 102, there is formed a transparent plate 101B made by the application or the pouring of an electrically insulating transparent material in liquid form. The electrically conductive transparent

25

material 110 shown in Figure 45 is made in the following way. On top of a transparent plate 111A, a plurality of electrically conductive wires 112 are arranged roughly in parallel, and then, while this structure is being heated, electrically conductive
30 wires 112 are pressed into the side of the transparent plate 111A with the application of pressure. Because of the melting of the transparent plate 111A, electrically conductive wires 112 is buried in the transparent

plate 111A. One portion of the electrically conductive wires 112 is buried in the transparent plate 111A, and on top of this plate, a transparent plate 111B is formed by the application or the pouring of an electrically insulating transparent material in liquid form. Reference numeral 111 in the figure is the base made of transparent plates 111A and 111B.

The electrically conductive transparent material 120 shown in Figure 46 is formed in one piece, when the base 121 is formed from an electrically insulating transparent material, by the burying of electrically conductive wires 122 in the material used in the formation at the same time.

The electrically conductive transparent materials 100 to 120 constructed as described above have their electrically conductive wires 102 to 122 placed off-center toward one side of the surfaces of the bases 101 to 121, so, as described above, by the dissolving of the substrate units 101 to 121 by use of a solvent, it is possible to expose terminals for the supply of electricity to the surfaces of the substrate units 101 to 121.

BRIEF DESCRIPTION OF THE DRAWINGS

Figure 1 is a sectional view of one example of an electrically conductive transparent material.

Figure 2 is a plan view of the electrically conductive transparent material.

Figure 3 is a sectional view of another example of an electrically conductive transparent material.

5 Figures 4A, 4B, and 4C are partial plan views of different conductive meshes.

10 Figure 5 is a perspective view of a display device using an electrically conductive transparent material.

 Figure 6 is a sectional view taken at line A-A of Figure 5.

15 Figure 7 is an electric circuit diagram of the display device.

20 Figure 8 is a sectional view of another example of an electrically conductive transparent material.

 Figure 9 is an electric circuit diagram.

25 Figure 10 is a plan view of still another example of an electrically conductive transparent material.

 Figure 11 is a sectional view taken at line A-A of Figure 10.

30 Figures 12 to 17 are plan views of different metal foils with a number of pores.

Figure 18 is a perspective view of another example of a display device.

5 Figures 19 to 21 are plan views of other examples of an electrically conductive transparent material.

10 Figure 22 is a sectional view of still another example of an electrically conductive transparent material.

Figure 23 is an electric circuit diagram.

15 Figure 24 is a fragmentary plan view of still another example of an electrically conductive transparent material.

20 Figure 25 is a perspective view of still another example of a display device.

Figure 26 is a plan view of still another example of an electrically conductive transparent material.

25 Figure 27 is a sectional view taken at line A-A of Figure 26.

Figures 28 to 36 are partial plan views of different conductive meshes.

30 Figure 37 is a sectional view of still another example of an electrically conductive transparent material.

Figure 38 is a sectional view of still another example of an electrically conductive transparent material.

5

Figure 39 is a plan view of still another example of an electrically conductive transparent material.

10

Figure 40 is a sectional view taken at line A-A of Figure 39.

Figure 41 is a fragmentary perspective view of the electrically conductive transparent material.

15

Figures 42 to 46 are sectional views of still other examples of an electrically conductive transparent material.

20

10, 20, 30, 30A, 40, 50, 60, 70, 80, 90, 100, 110, and 120 electrically conductive transparent materials.

25

11, 21, 31, 41, 51, 61, 71, 81, 91, 101, 111, and 121 substrate units.

30

12, 22, 32, 42, 52, 62, 72, 82, 92, 102, 112, and 122 electrically conductive transparent units.

13, 23, and 33 display elements.

CLAIMS

1. An electrically conductive transparent material comprising a substrate unit made of an electrically insulating transparent material, and an electrically
5 conductive transparent unit buried in said substrate unit, wherein said electrically conductive transparent unit is provided in the form of a plurality of layers at fixed intervals within said substrate unit.

10 2. An electrically conductive transparent material according to claim 1, wherein said electrically conductive transparent unit is provided in the form of an electrically conductive mesh.

15 3. An electrically conductive transparent material according to claim 2, wherein said conductive mesh is made of electrically conductive wires with a diameter of 0.1 mm or less.

20 4. An electrically conductive transparent material according to claim 1, wherein said electrically conductive transparent unit is provided in the form of a metal foil with a number of small pores.

25 5. An electrically conductive transparent material comprising a substrate unit made of an electrically insulating transparent material, and an electrically
30 conductive transparent unit buried in said substrate unit, wherein said electrically conductive transparent unit consists of a plurality of electrically conductive wires that are arranged approximately parallel.

6. An electrically conductive transparent material according to claim 5, wherein said electrically conductive wires have individual diameters of 0.1 mm or less.
- 5
7. An electrically conductive transparent material according to claim 5, wherein said electrically conductive transparent unit consists of a plurality of electrically conductive wires that do not intersect with each other and electrically insulating wires that are contained in a network of said plurality of electrically conductive wires.
- 10
8. An electrically conductive transparent material according to claim 7, wherein said electrically conductive wires and said electrically insulating wires have individual diameters of 0.1 mm or less.
- 15
9. An electrically conductive transparent material according to claim 1 or 5, wherein the substrate unit is provided with a number of holes for the exposure of transparent conductive portions of the electrically conductive transparent unit.
- 20
10. An electrically conductive transparent material according to claim 1 or 5, wherein said substrate unit is formed by the attachment of a plurality of constituent substrates together by an adhesive agent, and said electrically conductive transparent unit is arranged in the attached parts of said constituent substrates.
- 25
- 30

11. An electrically conductive transparent material according to claim 1 or 5, wherein said electrically conductive transparent unit is positioned from the central part in the direction of thickness of the substrate unit toward one surface of the substrate unit.

12. A display device comprising an electrically conductive transparent material according to claim 1 or 5 and display elements that, respectively, are connected electrically to feeder terminals for a plurality of transparent conductive portions provided for said electrically conductive transparent material.

13. A display device according to claim 12, wherein openings are formed in the substrate unit that is provided for said electrically conductive transparent material, and said display elements are placed in said openings so that the feeder terminals of the display elements are connected electrically with the transparent conductive portions that are exposed on said openings.

14. A display device according to claim 13, wherein a plurality of said display elements are positioned around said openings.

15. A display device according to claim 12, wherein said substrate unit is provided with concave portions for the exposure of said transparent conductive portions, and display elements are placed in said concave portions, so that said display elements are connected electrically with the transparent conductive

portions.

16. A display device according to claim 12, wherein a
plurality of said display elements are arranged along
5 the outside of said substrate unit, and display
elements are connected electrically with the
transparent conductive portions that are exposed on the
outer edge surface of said substrate unit.

Fig. 1

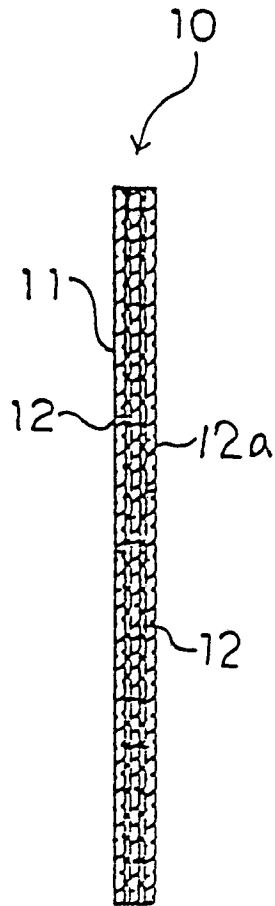

Fig. 2

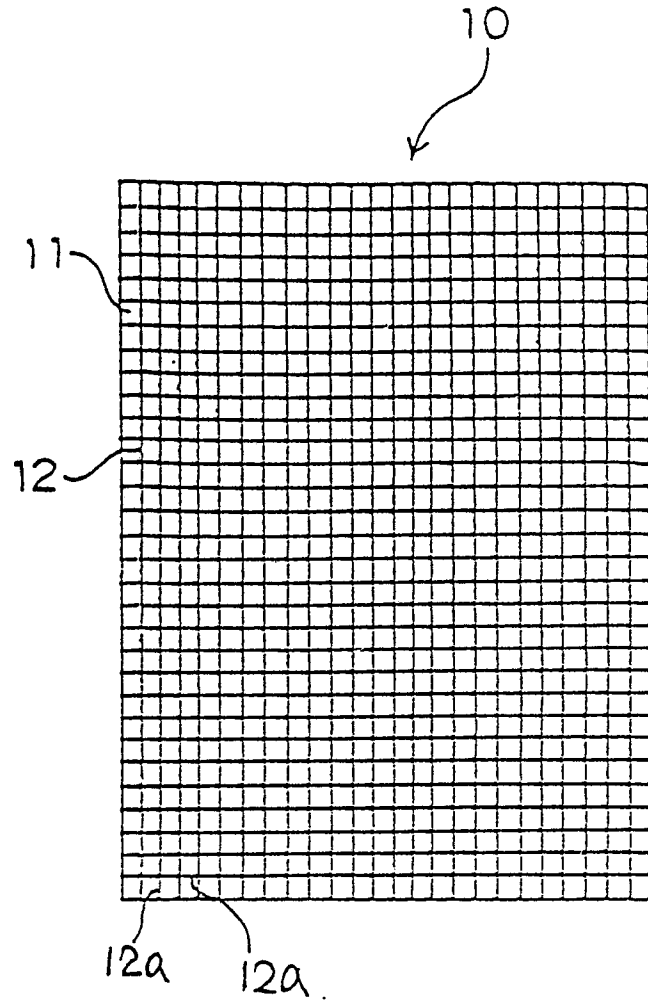

Fig. 3

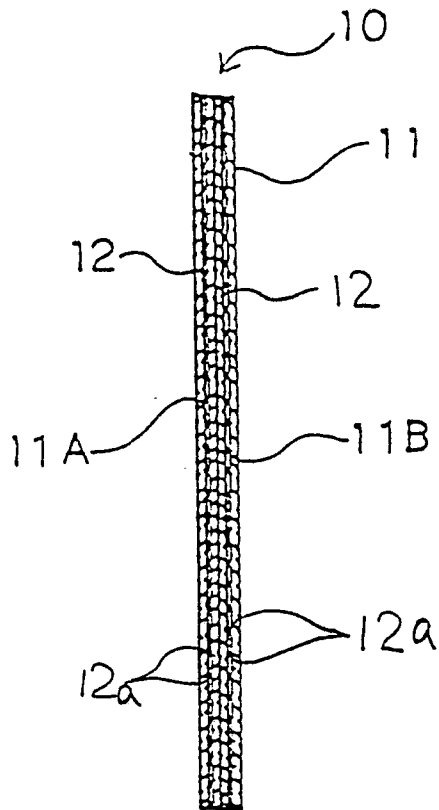

Fig. 4

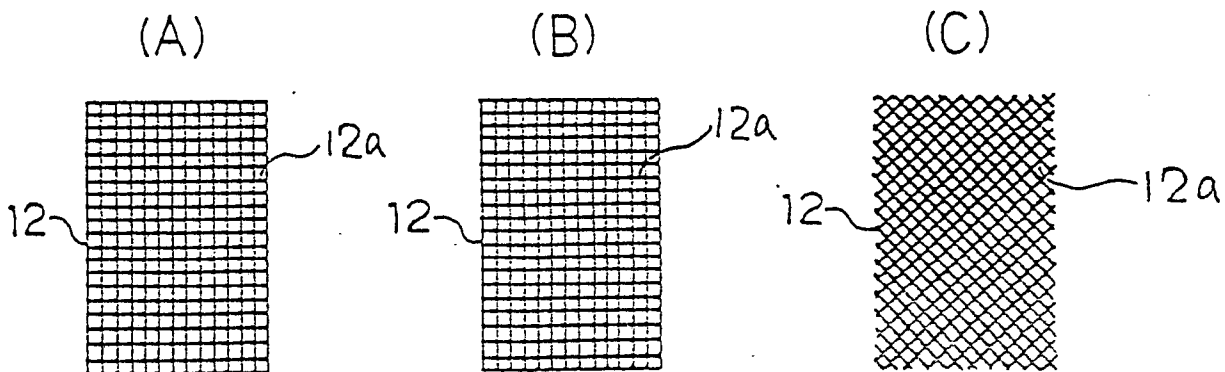

Fig. 5

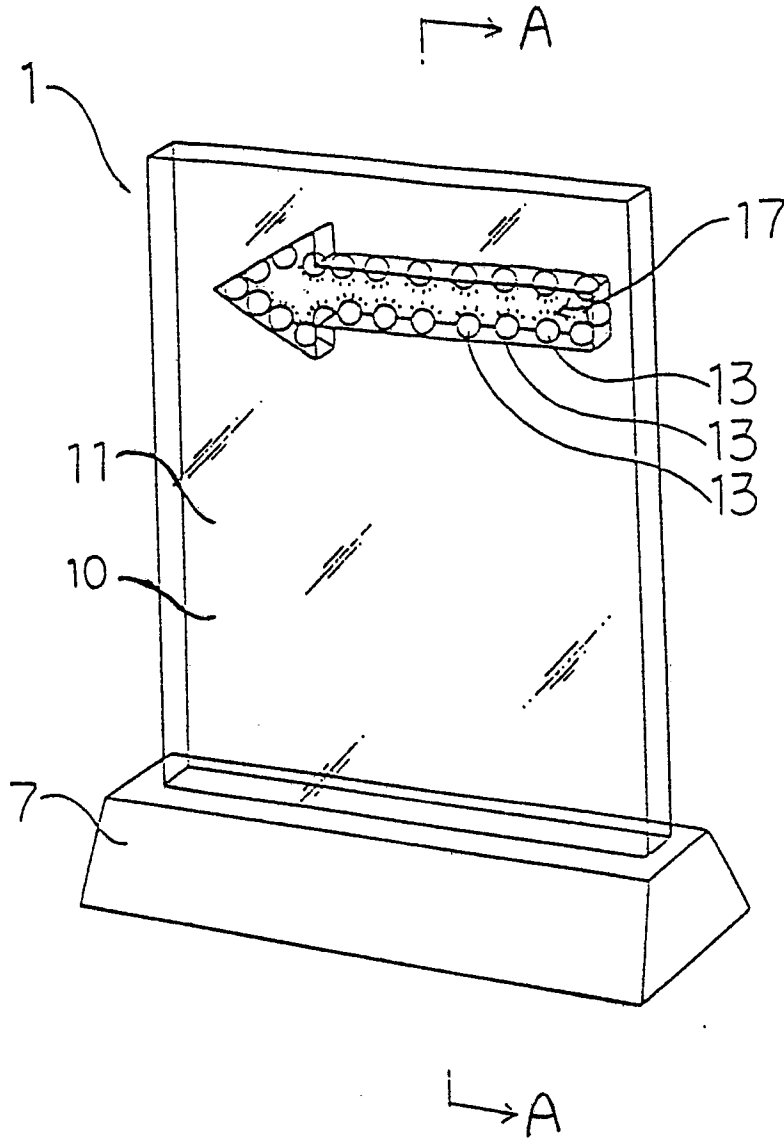

Fig. 6

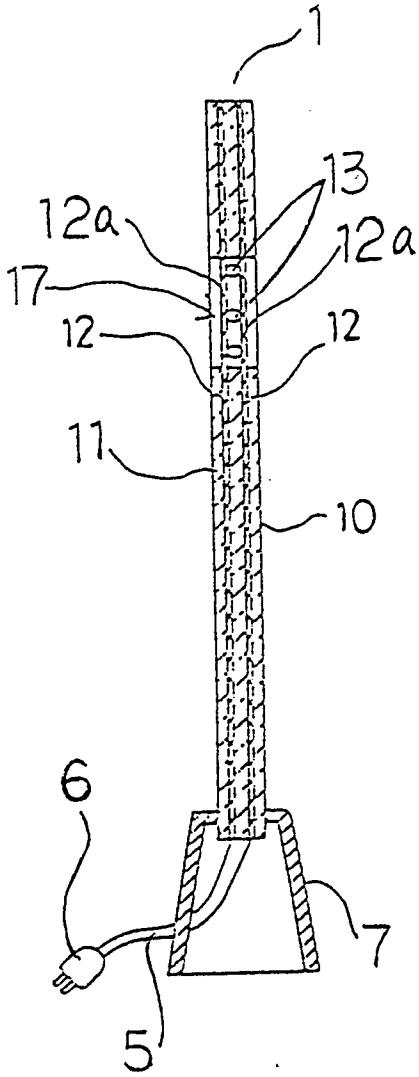

Fig. 7

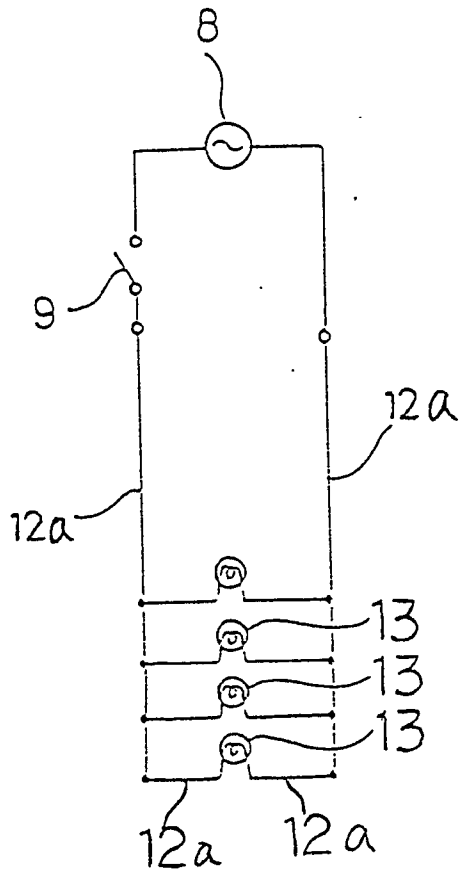

Fig. 8

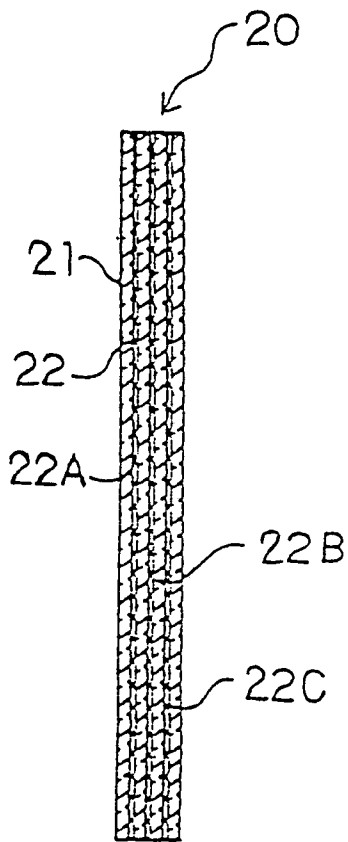

Fig. 9

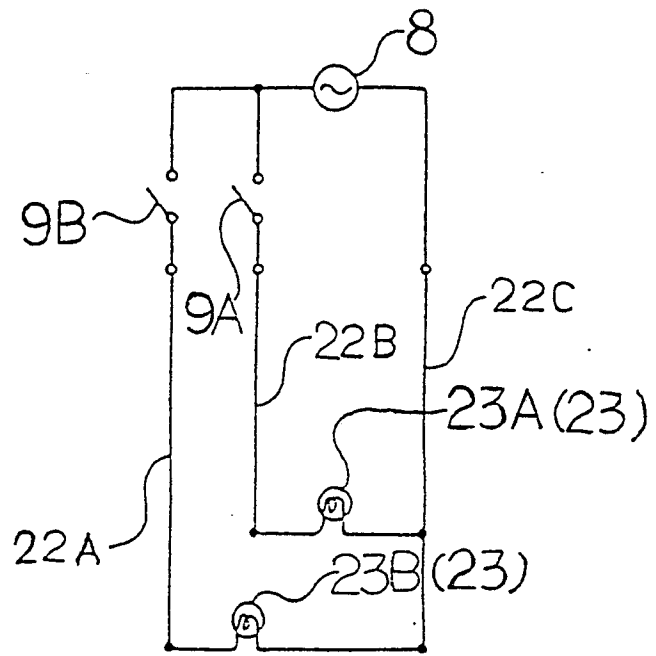

Fig. 10

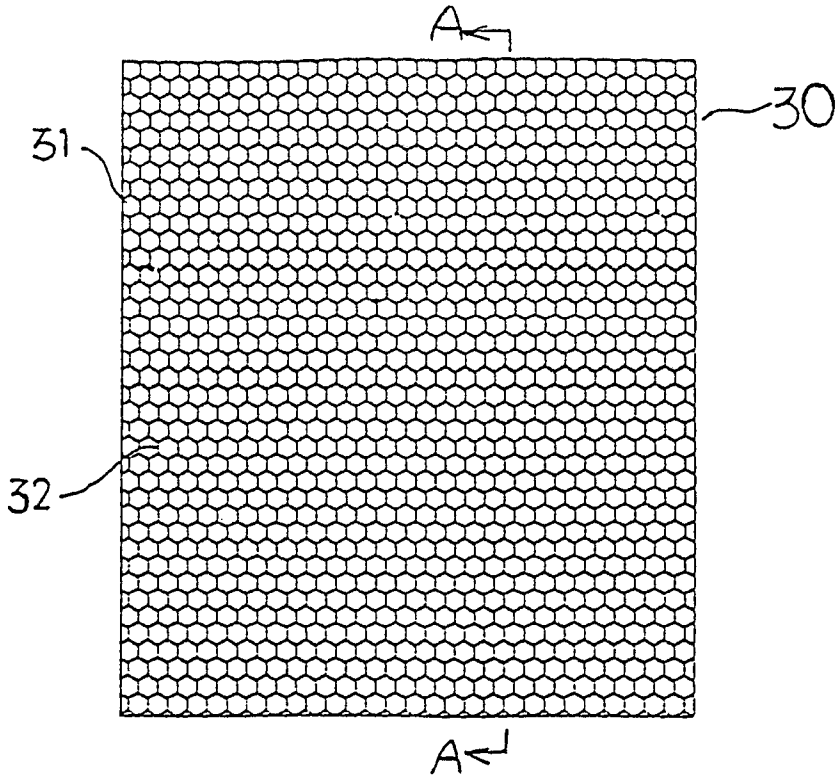
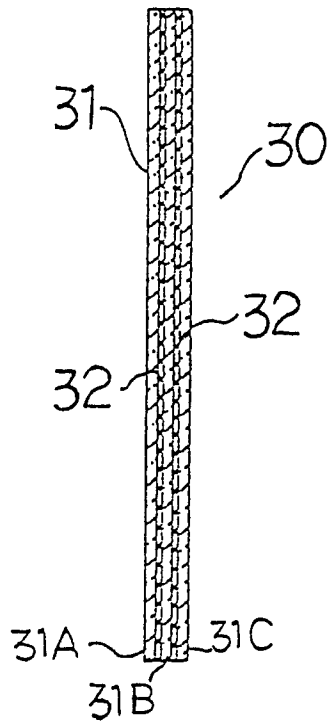

Fig. 11



7/21

Fig. 12

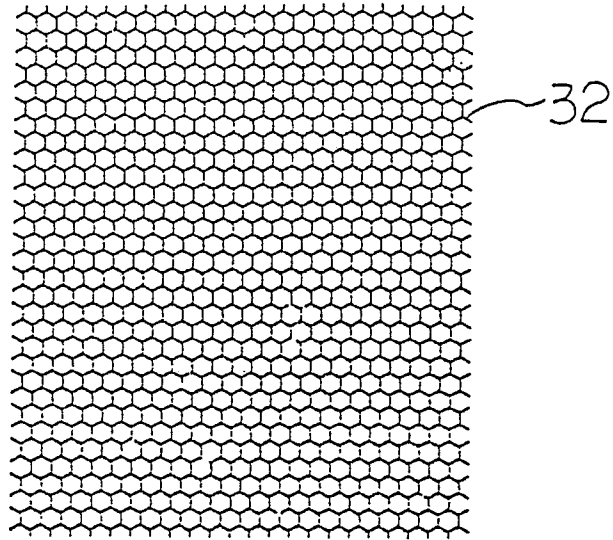

Fig. 13

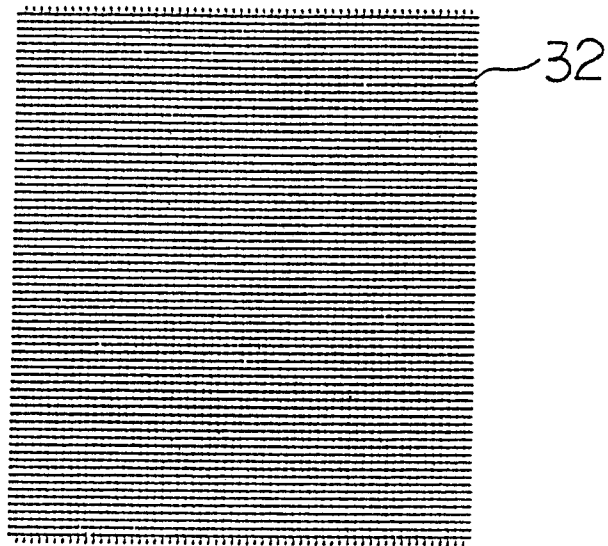

Fig. 14

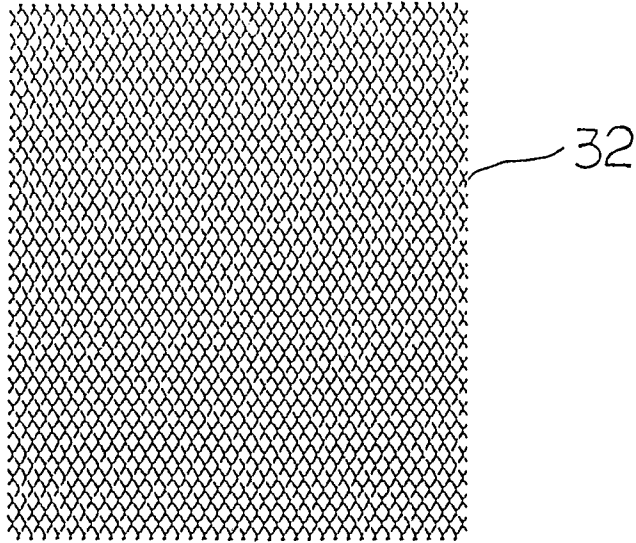

Fig. 15

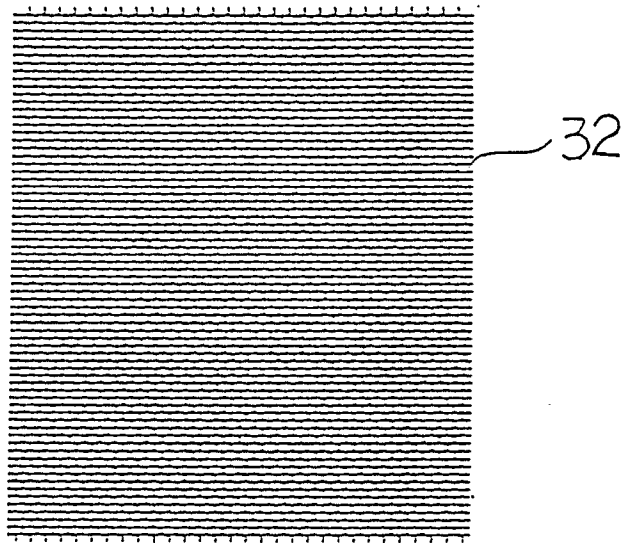

Fig. 16

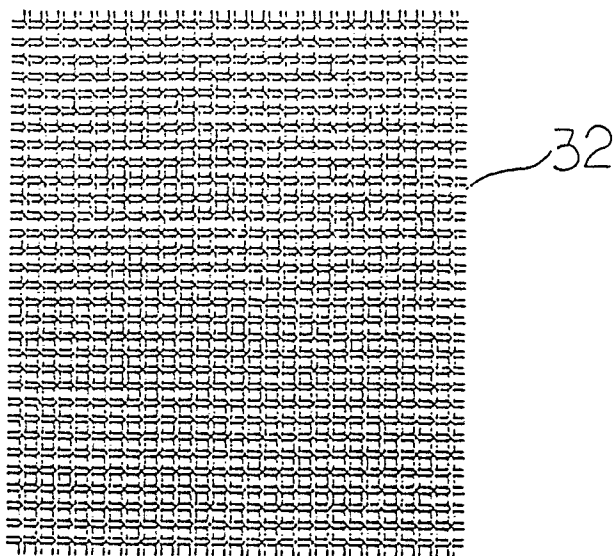

Fig. 17

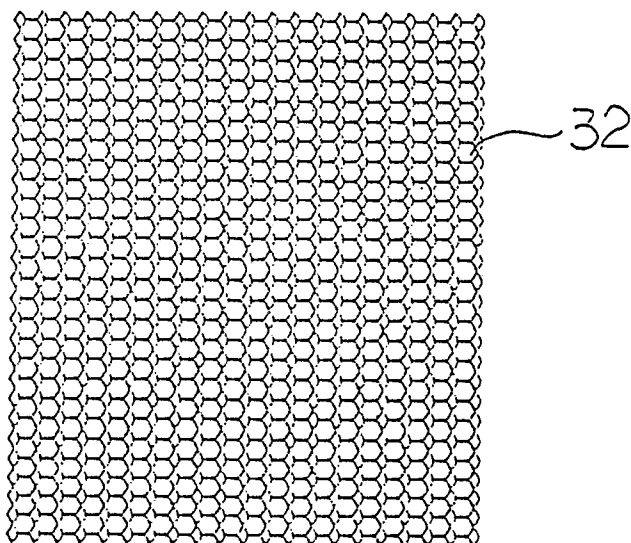

Fig. 18

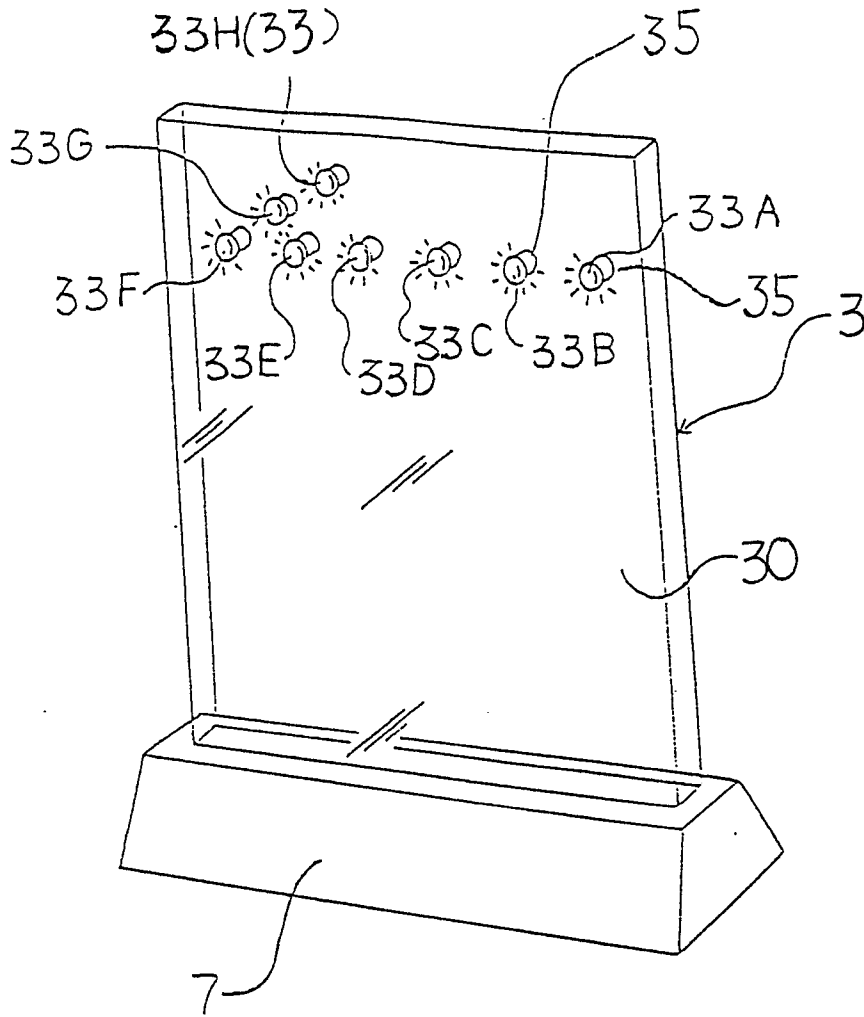

Fig. 19

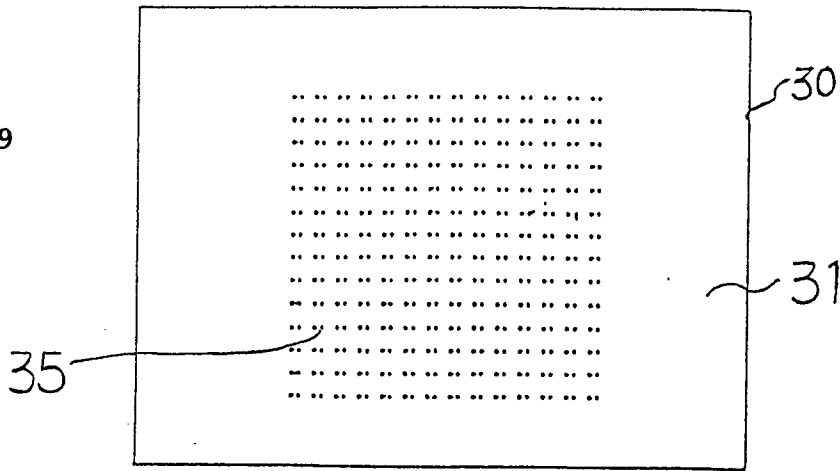

Fig. 20

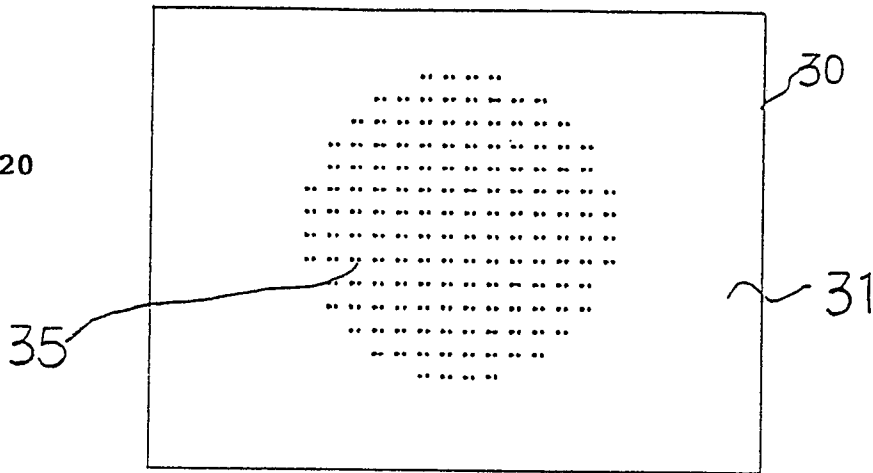

Fig. 21

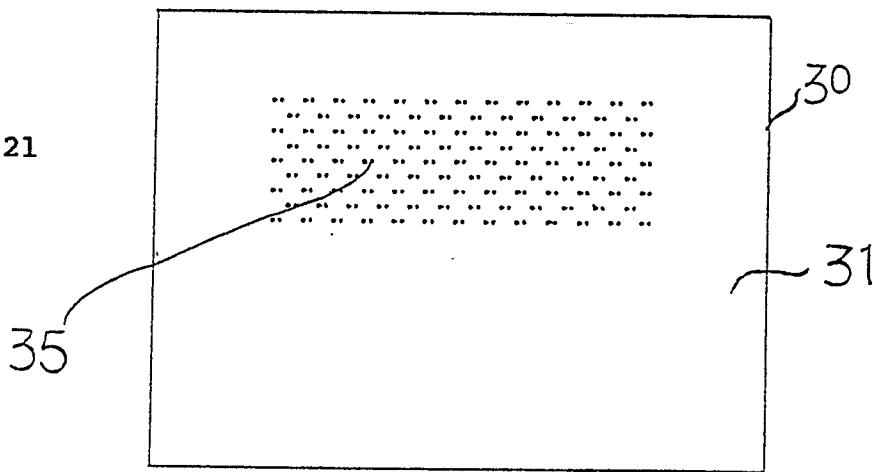

Fig. 22

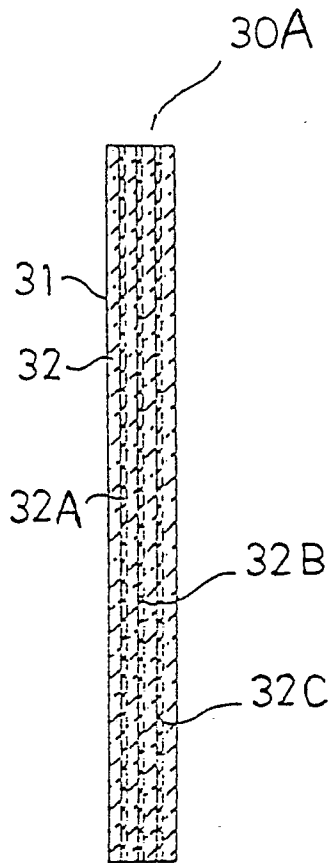

Fig. 23

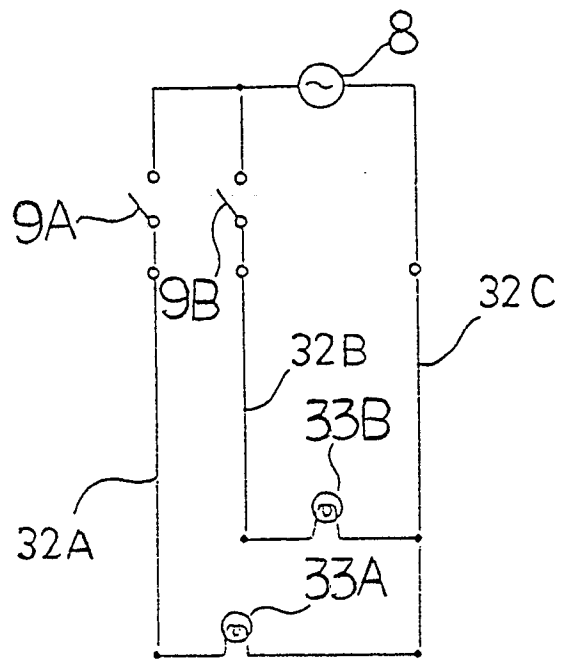

Fig. 24

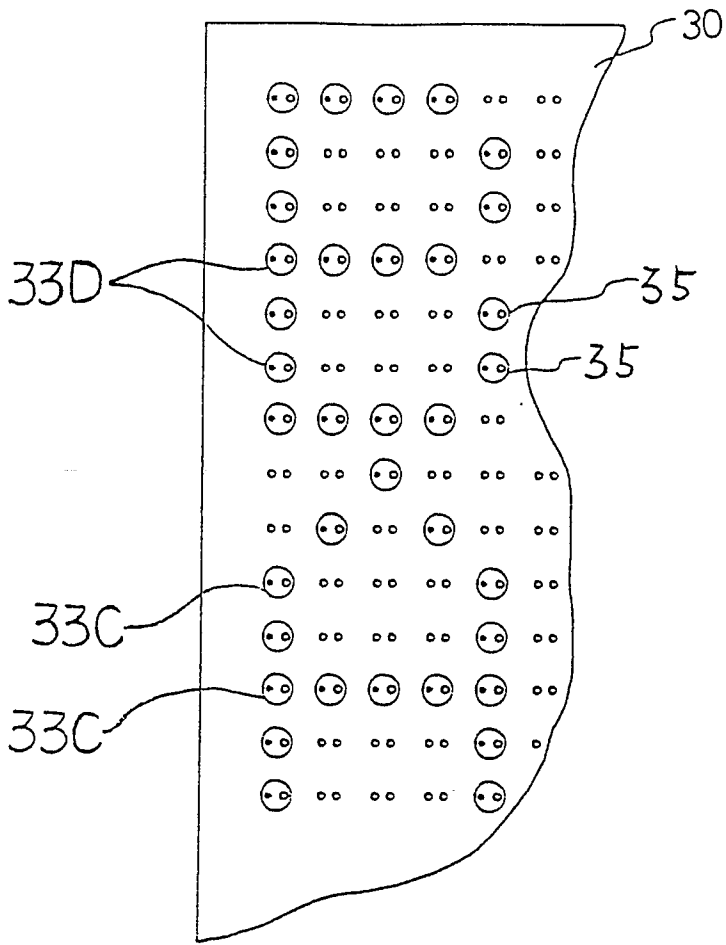

Fig. 25

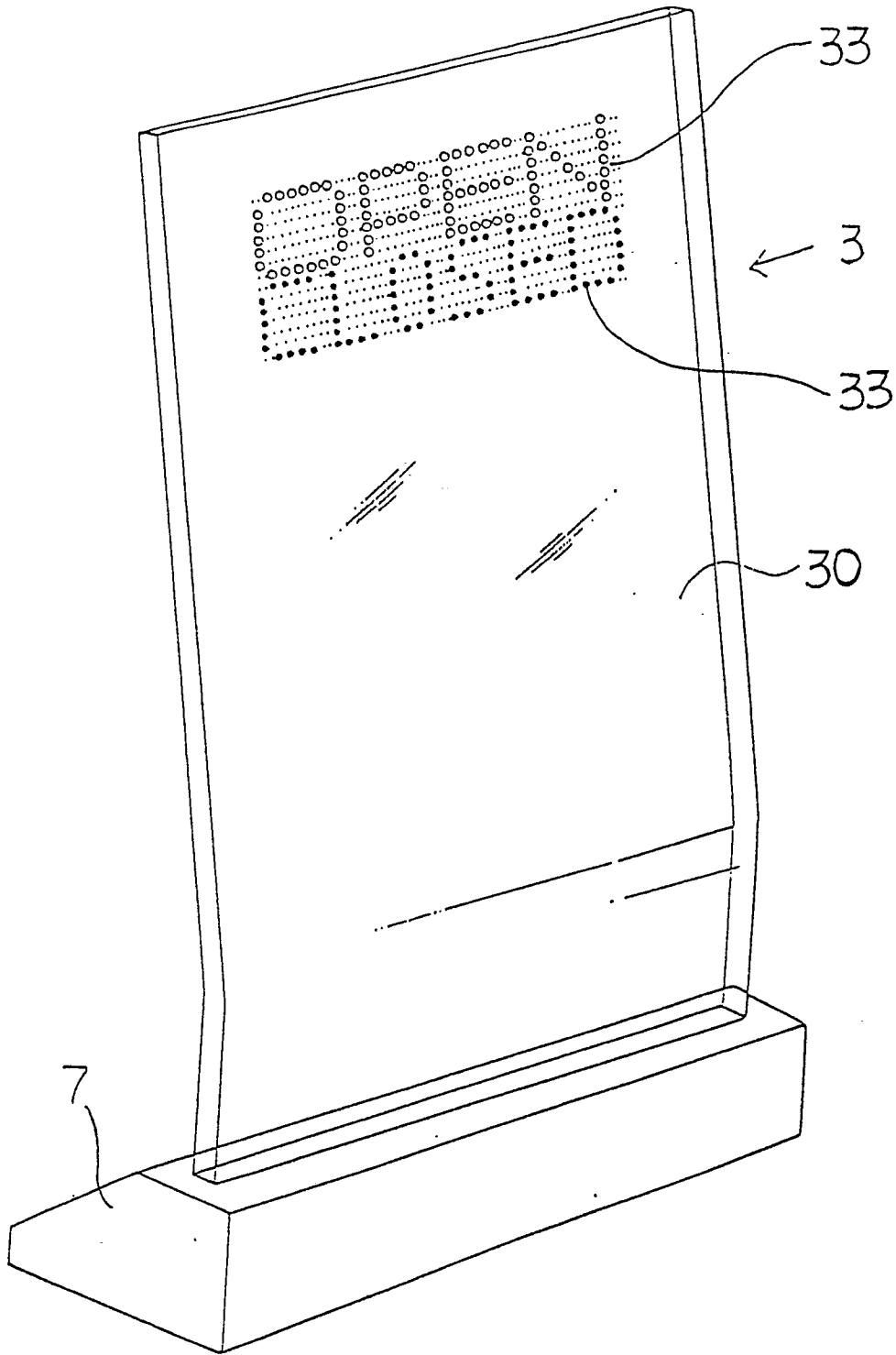

Fig. 26

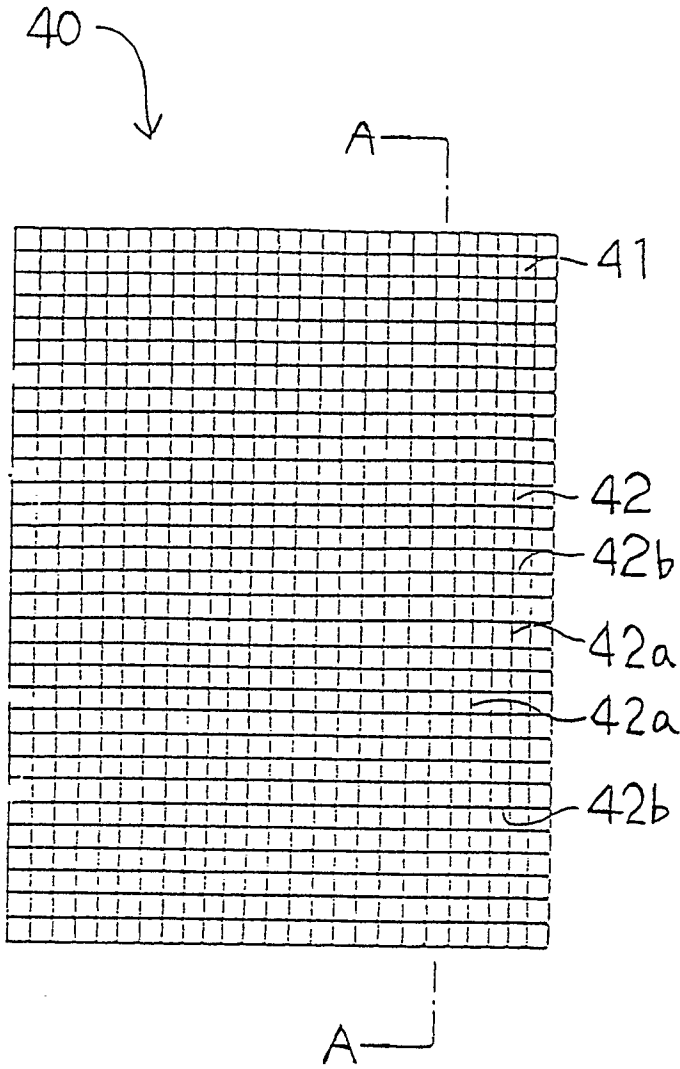

Fig. 27

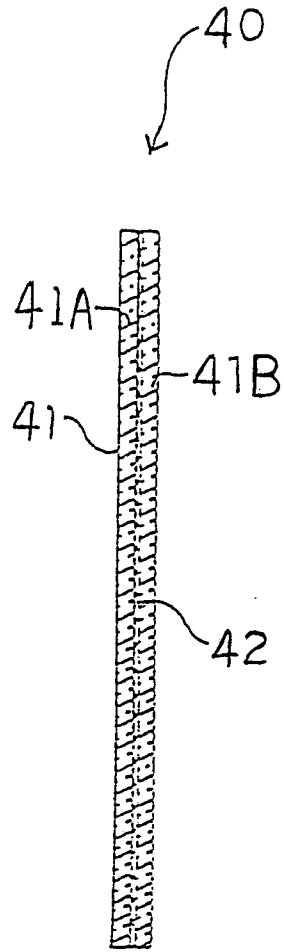

Fig. 28

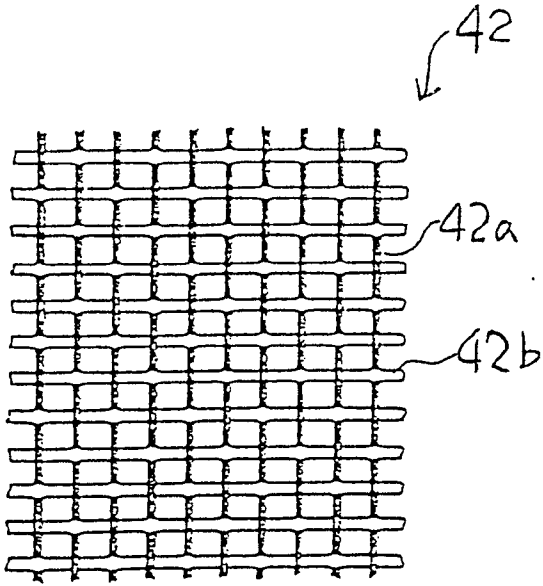

Fig. 29

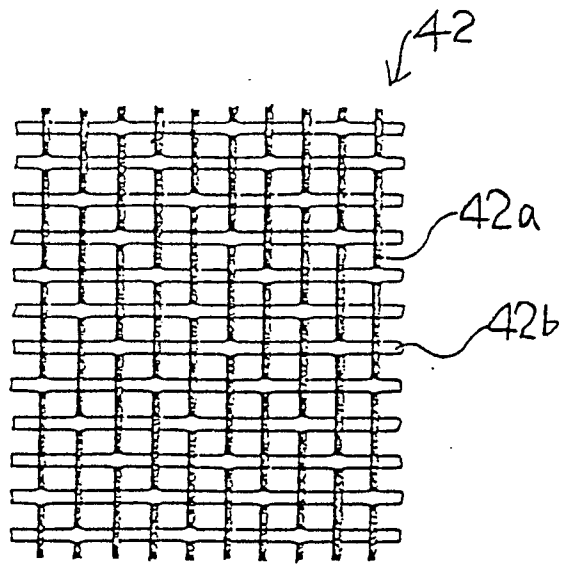

Fig. 30

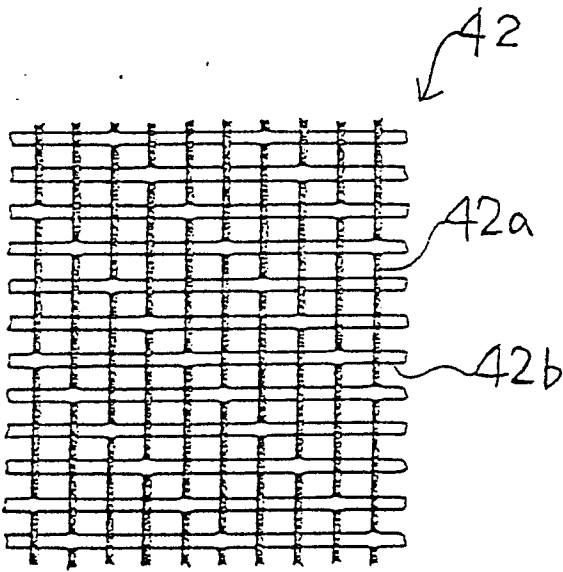

Fig. 31

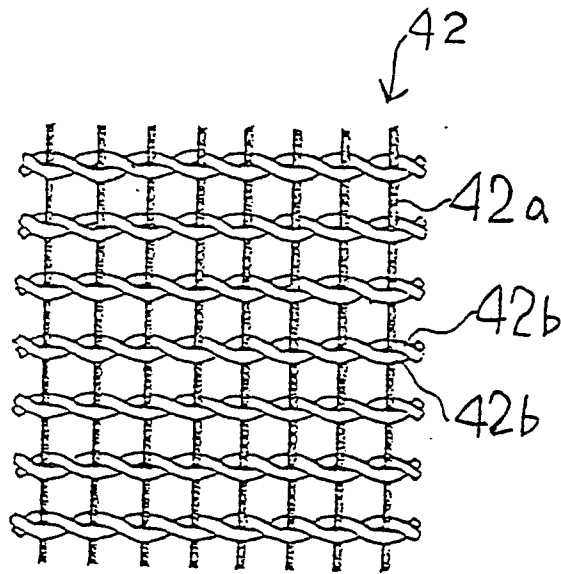

Fig. 32

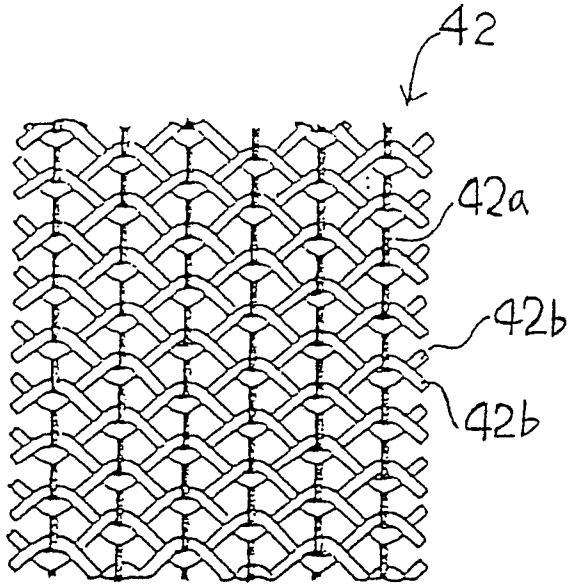

Fig. 33

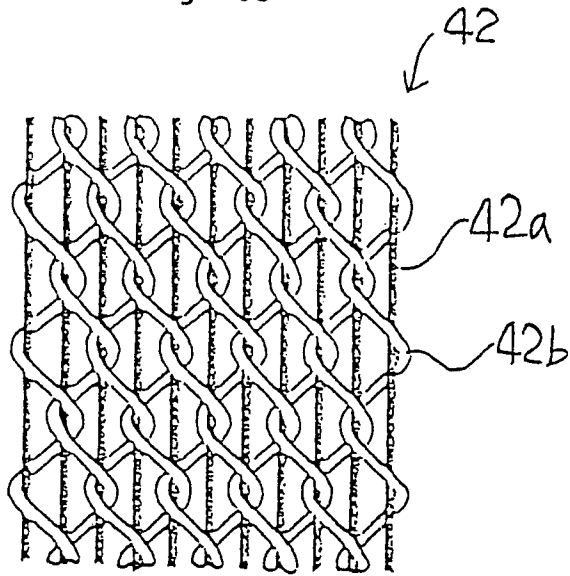

Fig. 34

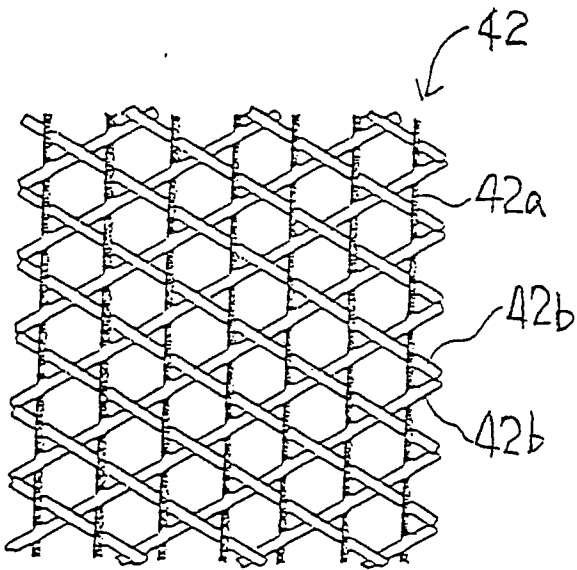

Fig. 35

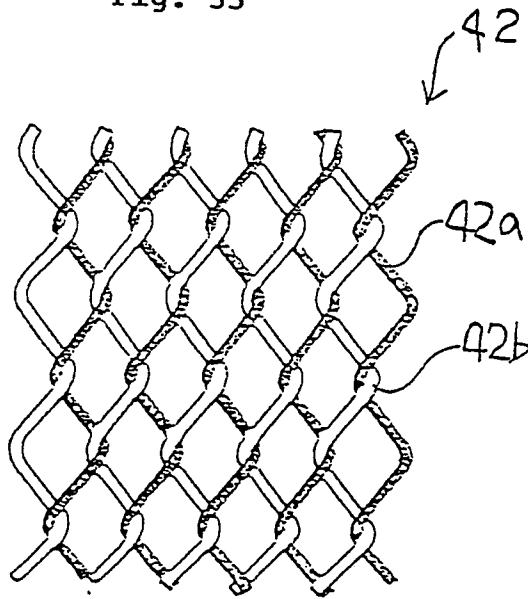

Fig. 36

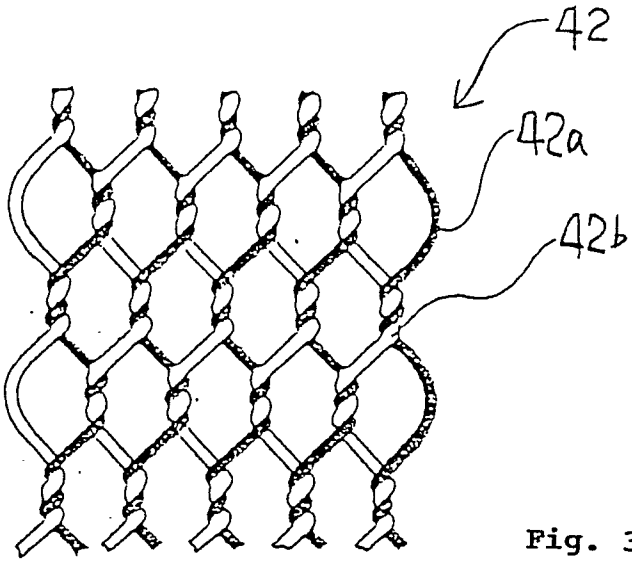

Fig. 37

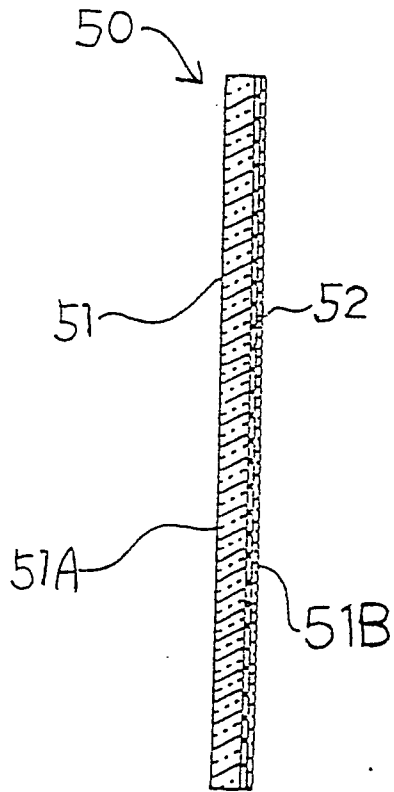

Fig. 38

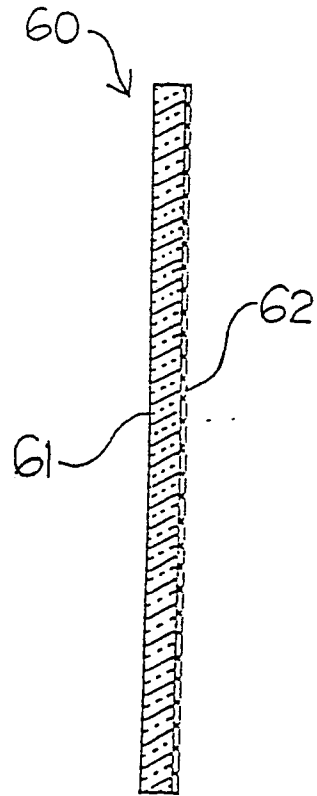

Fig. 39

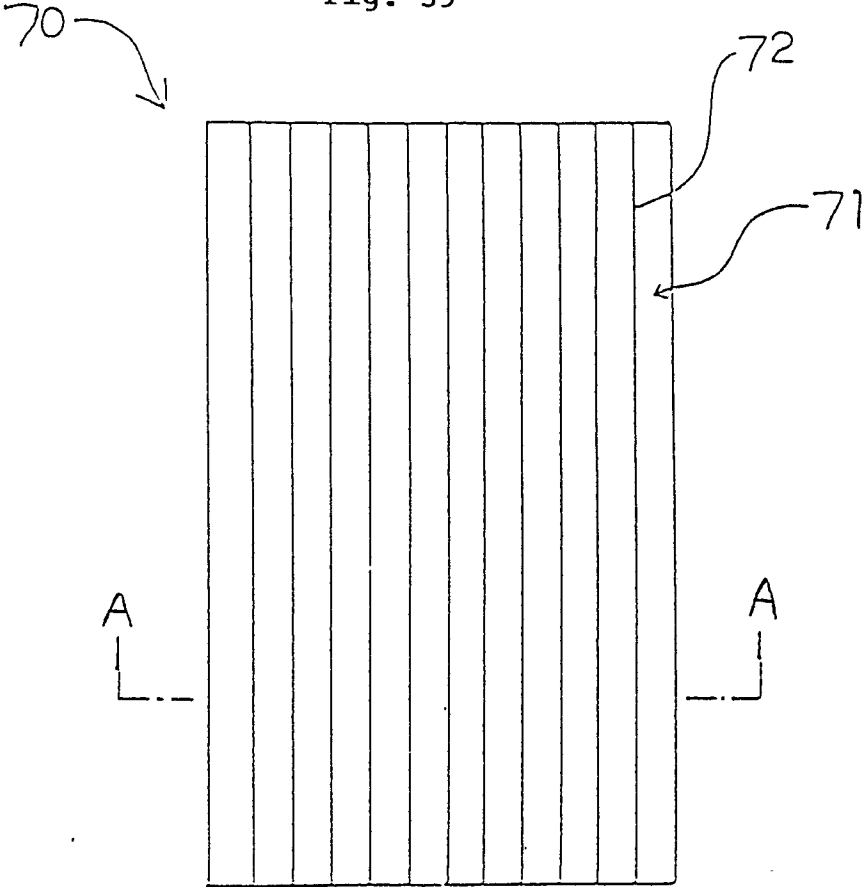

Fig. 40

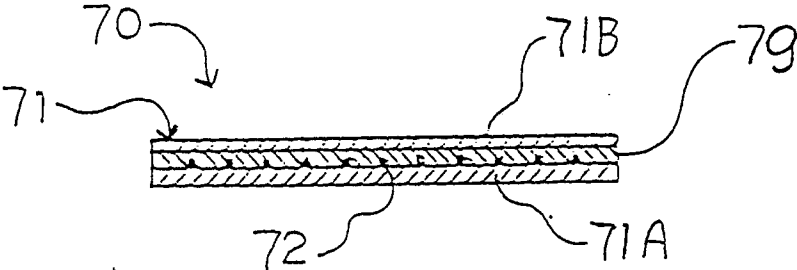

Fig. 41

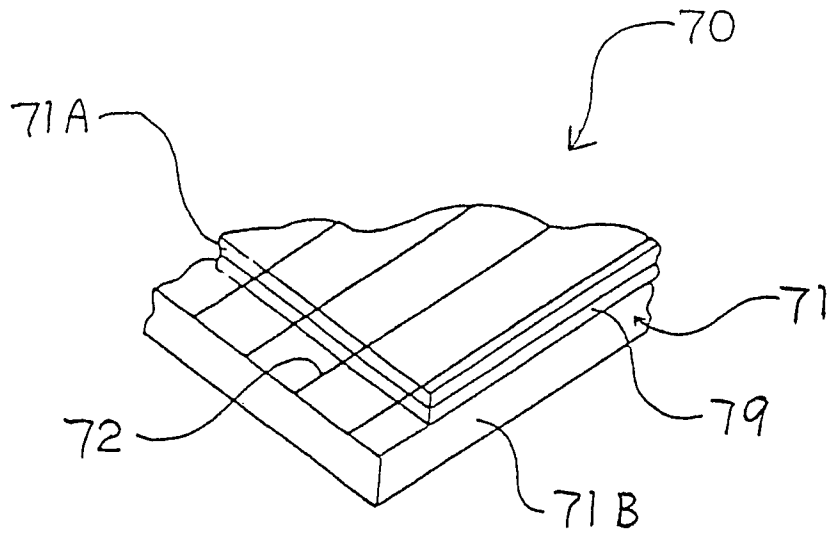

Fig. 42

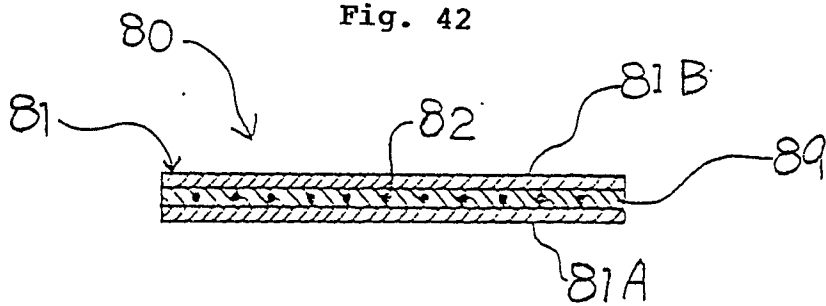

Fig. 43

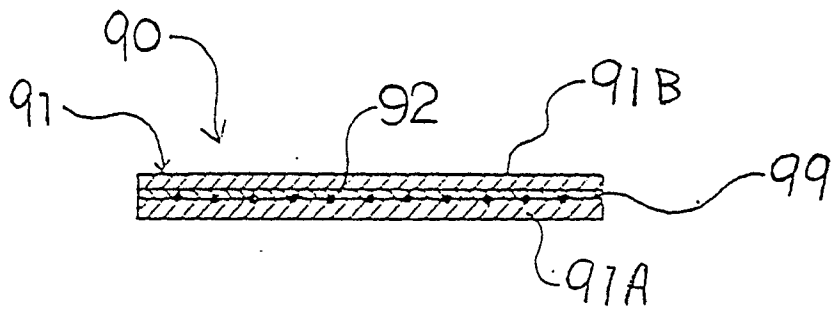

Fig. 44

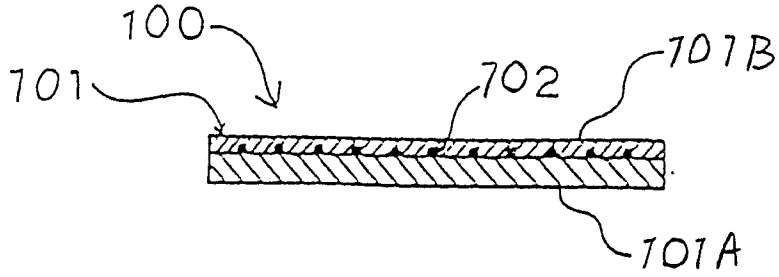

Fig. 45.

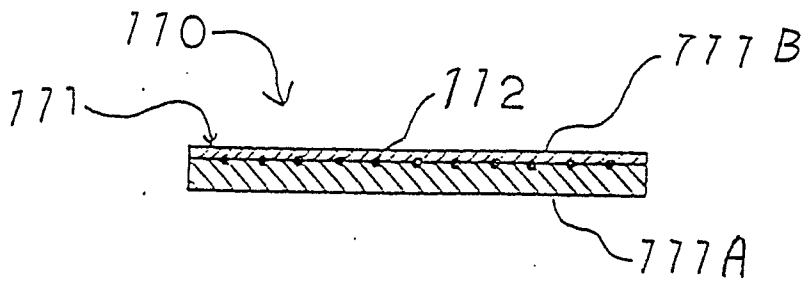
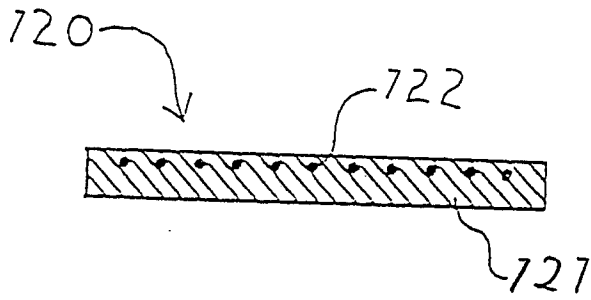

Fig. 46



INTERNATIONAL SEARCH REPORT

International Application No PCT/JP88/00024

I. CLASSIFICATION OF SUBJECT MATTER (if several classification symbols apply, indicate all) ³		
According to International Patent Classification (IPC) or to both National Classification and IPC		
Int.Cl ⁴ H01B5/14, H01B7/08, G09F13/00		
II. FIELDS SEARCHED		
Minimum Documentation Searched ⁴		
Classification System ¹	Classification Symbols	
IPC	H01B5/14, H01B7/08, G09F13/00	
Documentation Searched other than Minimum Documentation to the Extent that such Documents are Included in the Fields Searched ⁵		
Jitsuyo Shinan Koho	1926 - 1988	
Kokai Jitsuyo Shinan Koho	1971 - 1988	
III. DOCUMENTS CONSIDERED TO BE RELEVANT ¹⁴		
Category ⁶	Citation of Document, ¹⁶ with indication, where appropriate, of the relevant passages ¹⁷	Relevant to Claim No. ¹⁸
X	JP, B1, 32-3126 (Libbey-Owens-Ford Glass Co.) 27 May 1957 (27. 05. 57) Page 4, right column, lines 5 to 17 (Family: none)	1-11
Y	JP, A, 61-36360 (Nippon Telegraph & Telephone Corporation) 21 February 1986 (21. 02. 86) Fig. 2 (Family: none)	1-11
Y	JP, U, 61-119810 (Toyota Motor Corporation) 29 July 1986 (29. 07. 86) Fig. 1 (Family: none)	1-11
Y	JP, A, 57-6883 (Sharp Corporation) 13 January 1982 (13. 01. 82) Fig. 3 & US, A, 4446399	12-16
<p>¹⁵ Special categories of cited documents:</p> <p>"A" document defining the general state of the art which is not considered to be of particular relevance</p> <p>"E" earlier document but published on or after the international filing date</p> <p>"L" document which may throw doubts on priority claim(s) or which is cited to establish the publication date of another citation or other special reason (as specified)</p> <p>"O" document referring to an oral disclosure, use, exhibition or other means</p> <p>"P" document published prior to the international filing date but later than the priority date claimed</p> <p>"T" later document published after the international filing date or priority date and not in conflict with the application but cited to understand the principle or theory underlying the invention</p> <p>"X" document of particular relevance; the claimed invention cannot be considered novel or cannot be considered to involve an inventive step</p> <p>"Y" document of particular relevance; the claimed invention cannot be considered to involve an inventive step when the document is combined with one or more other such documents, such combination being obvious to a person skilled in the art</p> <p>"&" document member of the same patent family</p>		
IV. CERTIFICATION		
Date of the Actual Completion of the International Search ²	Date of Mailing of this International Search Report ²	
March 1, 1988 (01. 03. 88)	March 14, 1988 (14. 03. 88)	
International Searching Authority ¹	Signature of Authorized Officer ²⁰	
Japanese Patent Office		

FURTHER INFORMATION CONTINUED FROM THE SECOND SHEET

Y.	JP, B2, 52-40960 (Matsushita Electric Ind. Co., Ltd.) 15 October 1977 (15. 10. 77) Column 1, lines 21 to 33 & DE, A1, 2345372 & FR, A5, 2198676 & JP, A, 49-64333 & GB, A, 1437803 & CA, A1, 1006954 & US, A, 4015166 & JP, B2, 52-37914 & DE, B2, 2345372 & DE, C3, 2345372	12-16
----	--	-------

V. OBSERVATIONS WHERE CERTAIN CLAIMS WERE FOUND UNSEARCHABLE¹⁰

This international search report has not been established in respect of certain claims under Article 17(2) (a) for the following reasons:

1. Claim numbers..... because they relate to subject matter¹² not required to be searched by this Authority, namely:
2. Claim numbers..... because they relate to parts of the international application that do not comply with the prescribed requirements to such an extent that no meaningful international search can be carried out¹³, specifically:

VI. OBSERVATIONS WHERE UNITY OF INVENTION IS LACKING¹¹

This International Searching Authority found multiple inventions in this international application as follows:

1. As all required additional search fees were timely paid by the applicant, this international search report covers all searchable claims of the international application.
2. As only some of the required additional search fees were timely paid by the applicant, this international search report covers only those claims of the international application for which fees were paid, specifically claims:
3. No required additional search fees were timely paid by the applicant. Consequently, this international search report is restricted to the invention first mentioned in the claims; it is covered by claim numbers:
4. As all searchable claims could be searched without effort justifying an additional fee, the International Searching Authority did not invite payment of any additional fee.

Remark on Protest

- The additional search fees were accompanied by applicant's protest.
- No protest accompanied the payment of additional search fees.