

(19) World Intellectual Property Organization  
International Bureau



(43) International Publication Date  
21 December 2000 (21.12.2000)

PCT

(10) International Publication Number  
WO 00/77963 A1

- (51) International Patent Classification<sup>7</sup>: H04K 1/00, H04B 7/00
- (74) Agents: HAAS, Kenneth, A./KAH et al.; Motorola Inc., Intellectual Property Dept., 1303 East Algonquin Road, Schaumburg, IL 60196 (US).
- (21) International Application Number: PCT/US00/06028
- (81) Designated States (*national*): BR, JP, KR.
- (22) International Filing Date: 8 March 2000 (08.03.2000)
- (84) Designated States (*regional*): European patent (AT, BE, CH, CY, DE, DK, ES, FI, FR, GB, GR, IE, IT, LU, MC, NL, PT, SE).
- (25) Filing Language: English
- (26) Publication Language: English
- (30) Priority Data: 09/332,923 14 June 1999 (14.06.1999) US
- Published: — With international search report.
- (71) Applicant: MOTOROLA INC. [US/US]; 1303 East Algonquin Road, Schaumburg, IL 60196 (US).
- For two-letter codes and other abbreviations, refer to the "Guidance Notes on Codes and Abbreviations" appearing at the beginning of each regular issue of the PCT Gazette.
- (72) Inventors: PETERSON, Roger, Laurin; 2105 Greenock, Inverness, IL 60067 (US). SEOANE, Jorge, Luis; P.O. Box 2148, West Lafayette, IN 47906 (US).

(54) Title: INTERLEAVING IN A SPREAD-SPECTRUM COMMUNICATION SYSTEM

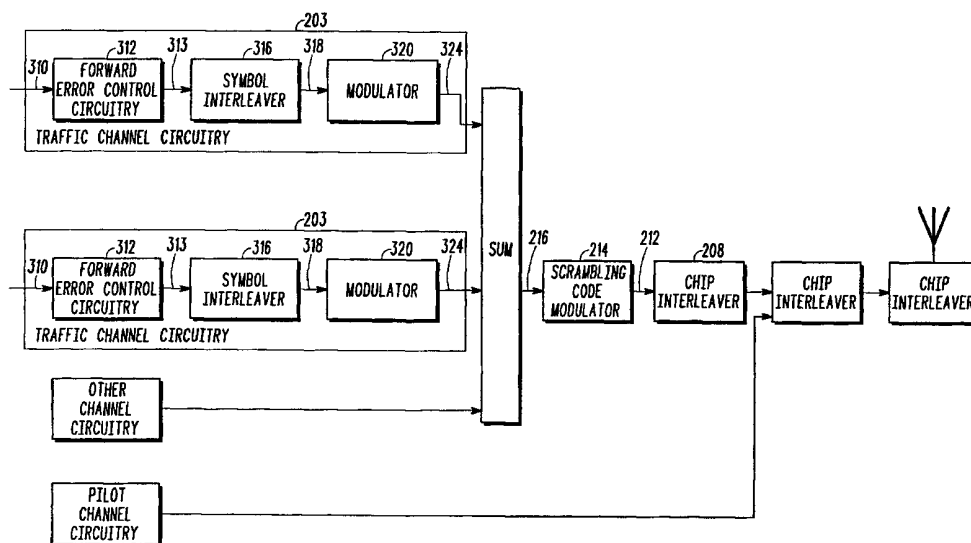

(57) Abstract: In order to deliver reliable information in a noisy signal environment spread user data is interleaved at the chip level. In particular, a spread sequence (212) enters a second interleaver (chip interleaver (208)). The interleaver (208) interleaves the input chips at the chip level. Within the interleaver (208), chips are individually input into a matrix which defines a predetermined size blocks of chips. For example, the chips are input into locations within the matrix so that the matrix is filled in a column by column manner. Chips are individually output from locations within the matrix so that the matrix is emptied in a row by row manner.

WO 00/77963 A1

## INTERLEAVING IN A SPREAD-SPECTRUM COMMUNICATION SYSTEM

## Field of the Invention

5

The present invention relates generally to communication systems and, in particular, to interleaving in a direct-sequence spread-spectrum communication system.

10

## Background of the Invention

Communication systems take many forms. In general, the purpose of a communication system to transmit information-bearing signals from a source, located at one point, to a user destination, located at another point some distance away. A communication system generally consists of three basic components: transmitter, channel, and receiver. The transmitter has the function of processing the message signal into a form suitable for transmission over the channel. This processing of the message signal is referred to as modulation. The function of the channel is to provide a physical connection between the transmitter output and the receiver input. The function of the receiver is to process the received signal so as to produce an estimate of the original message signal. This processing of the received signal is referred to as demodulation.

Analog and digital transmission methods are used to transmit a message signal over a communication channel. The use of digital methods offers several operational advantages over analog methods, including but not limited to: increased immunity to channel noise and interference, flexible operation of the system, common format for the transmission of different kinds of message signals, improved security of communication through the use of encryption and increased capacity.

To transmit a message signal (either analog or digital) over a communication channel having an assigned channel bandwidth, the message signal must be manipulated into a form suitable for efficient transmission over the channel. Modification of the message signal is achieved by means of a process

-2-

termed modulation. This process involves varying some parameter of a carrier wave in accordance with the message signal in such a way that the spectrum of the modulated wave matches the assigned channel bandwidth. Parameters of a carrier wave that can be varied include amplitude, frequency, and or phase.  
5 Correspondingly, the receiver is required to re-create the original message signal from a degraded version of the transmitted signal after propagation through the channel. The re-creation is accomplished by using a process known as demodulation, which is the inverse of the modulation process used in the transmitter.

10 With digital communication, user information such as speech is encoded into sequences of binary information symbols. This encoding is convenient for modulation and is easily error-correction coded for transmission over a potentially degrading communication channel. Such binary information is particularly amenable to transmission using "direct sequence" spread spectrum modulation.  
15 With direct sequence, digital information is spread with a spreading code whose bit rate is much higher than the information signal itself. Although the spreading can be accomplished by several methods, the most common is to modulo-2 add each bit of information (generally after appropriate error correction coding) to a sequence of bits of the spreading code. Thus as desired for the spreading process,  
20 many bits are generated for each coded information bit that is desired to be transmitted.

Advantages from direct sequence spread spectrum communication systems are obtained since the receiver is knowledgeable of the spreading code used to spread the user signal. As is well known in the art the receiver, after appropriate  
25 synchronization to the receive signal, is able to decode the wide bandwidth spread signal using a replica of the spreading sequence. Another advantage of spread spectrum communication systems is the ability to provide multiple access capability. Specifically, cellular telephone communication systems have been designed to incorporate the characteristic of communicating with many remote  
30 units on the same communication channel.

One type of multiple access spread spectrum communication system realized with direct sequence spread spectrum is a code division multiple access (CDMA) communication system. In a CDMA communication system, communication between two communication units is accomplished by spreading

- 3 -

each transmitted signal over the frequency band of the communication channel with a unique user spreading code. As a result, transmitted signals are in the same frequency band of the communication channel and are distinguished only by being assigned unique user spreading codes. Particular transmitted signals are retrieved  
5 from the communication channel by despreading a signal which is the sum of signals in the communication channel with a user spreading code related to the particular transmitted signal which is to be retrieved from the communication channel. Specially suited spreading codes may be employed to reduce the interference created by the sum of all the other signals present on the same  
10 channel. Orthogonal codes are typically used for this purpose, and of these, the Walsh codes are most common.

A spread spectrum system provides, among other things, robustness to jamming, good interference and multipath rejection, and inherently secure communications from eavesdroppers. The essence of the spread spectrum  
15 communication involves expanding the bandwidth of a signal, transmitting the expanded signal and recovering the desired signal by re-mapping the received spread spectrum into the original information bandwidth. Furthermore, in the process of carrying out this series of bandwidth trades, the purpose of spread spectrum techniques is to allow the system to deliver reliable information in a  
20 noisy signal environment. In order to deliver reliable information in a noisy environment, many techniques (e.g., convolutional encoding, interleaving at the symbol level, . . . , etc.) are utilized to improve the quality of the demodulated signal. Although these techniques greatly improve the reliability of information transmitted, situations exist where current techniques are inadequate to provide  
25 reliable information in noisy environments. Consequently there exists a need for a method and apparatus for improving the reliability of signals transmitted in spread-spectrum communication systems.

#### Brief Description of the Drawings

30

FIG. 1 is a block diagram of a communication system in accordance with the preferred embodiment of the present invention.

FIG. 2 is a block diagram of a base station in accordance with the preferred embodiment of the present invention.

- 4 -

FIG. 3 is a flow chart showing operation of the base station of FIG. 1 in accordance with the preferred embodiment of the present invention.

FIG. 4 is a block diagram of a remote unit in accordance with the preferred embodiment of the present invention.

5

### Detailed Description of the Drawings

To address the above-mentioned need a method and apparatus for interleaving in a spread-spectrum communication system is provided herein. In order to deliver reliable information in a noisy signal environment spread user data is interleaved at the chip level. In particular, a spread sequence enters a second interleaver (chip interleaver). The interleaver interleaves the input chips at the chip level. Within the interleaver, chips are individually input into a matrix which defines a predetermined size block of chips. For example, the chips are input into locations within the matrix so that the matrix is filled in a column by column manner. Chips are individually output from locations within the matrix so that the matrix is emptied in a row by row manner.

Interleaving in such a way improves transmission quality over a flat fading channel due to the increased time diversity achieved through chip interleaving. This chip level time diversity supplements the symbol level time diversity already available through the symbol interleaver and the forward error control scheme. Benefits are also achieved in multipath fading (i.e. non-flat fading) although in these cases other types of diversity are possible. The benefit of chip interleaving is particularly important when the spreading modulation is itself a coded modulation where, for example, information is transmitted by the selection of a set of  $n$  orthogonal codes from a larger set  $N$  of orthogonal codes. Benefits are achieved in spite of the fact that chip interleaving degrades the orthogonality of the spreading code sets.

The present invention encompasses a method for interleaving in a spread-spectrum communication system. The method comprises the steps of receiving a first set of data at a first data rate and performing a first interleaving of the first set of data to produce interleaved symbols. The interleaved symbols are spread with a spreading code whose data rate is greater than the first data rate to produce spread

30

-5-

symbols and a second interleaving of the spread symbols is performed to produce spread symbols interleaved at a chip level.

The present invention additionally encompasses method for interleaving in a spread-spectrum communication system where digital information is spread with a spreading code whose bit rate is higher than a data rate of the digital information. The method comprises the steps of receiving spread digital information comprising a plurality of chips and interleaving the plurality of chips to produce an interleaved plurality of chips.

The present invention additionally encompasses an apparatus comprising a chip interleaver having spread data as an input and outputting interleaved spread data, wherein the interleaved spread data is interleaved at a chip level.

The present invention additionally encompasses a method in a communication system where spread data is interleaved at a chip level and then transmitted. The method comprises the steps of receiving the spread data that is interleaved at the chip level and de-interleaving at the chip level, the spread data interleaved at the chip level.

Finally, the present invention encompasses an apparatus comprising a chip de-interleaver having spread data as an input, wherein the spread data is interleaved at a chip level, wherein the chip de-interleaver outputs de-interleaved spread data.

Turning now to the drawings, where like numerals designate like components, FIG. 1 is a block diagram of communication system 100 in accordance with the preferred embodiment of the present invention. In the preferred embodiment of the present invention, communication system 100 utilizes a direct-sequence Code Division Multiple Access (CDMA) system protocol as described in Cellular System Remote unit-Base Station Compatibility Standard of the Electronic Industry Association/Telecommunications Industry Association Interim Standard 95C (TIA/EIA/IS-95C), which is incorporated by reference herein. (EIA/TIA can be contacted at 2001 Pennsylvania Ave. NW Washington DC 20006). However, in alternate embodiments communication system 100 may utilize other digital cellular communication system protocols such as, but not limited to, the next generation CDMA architecture as described in the UMTS Wideband cdma SMG2 UMTS Physical Layer Expert Group Tdoc SMG2 UMTS-L1 221/98 (UMTS 221/98), the next generation CDMA architecture as

-6-

described in the cdma2000 International Telecommunication Union-Radiocommunication (ITU-R) Radio Transmission Technology (RTT) Candidate Submission document, or the CDMA system protocol as described in "Personal Station-Base Station Compatibility Requirements for 1.8 to 2.0 GHz Code  
5 Division Multiple Access (CDMA) Personal Communication Systems" (American National Standards Institute (ANSI) J-STD-008), or the European Telecommunications Standards Institute (ETSI) Wideband CDMA (W-CDMA) protocol. The present invention is also applicable to direct-sequence spread spectrum systems which utilize code selection techniques to convey information.  
10 For example, user information may be transmitted via the particular selection of a plurality of  $n$  orthogonal waveforms from a larger plurality of  $N$  orthogonal waveforms. The present invention is applicable to both the forward and reverse transmission paths of these communication systems.

Communication system 100 includes a number of network elements such  
15 as base station 101, remote unit 113, Centralized Base Station Controller (CBSC) 103, and Mobile Switching Center (MSC) 104. It is contemplated that network elements within communication system 100 are configured in well known manners with processors, memories, instruction sets, and the like, which function in any suitable manner to perform the function set forth herein.

20 As shown, remote unit 113 is communicating with base station 101 via uplink communication signals 119 and base station 101 is communicating with remote unit 113 via downlink communication signals 116. In the preferred embodiment of the present invention, base station 101 is suitably coupled to CBSC 103, and CBSC 103 is suitably coupled to MSC 104.

25 FIG. 2 is a block diagram of base station 101 in accordance with the preferred embodiment of the present invention. As shown, base station 101 may utilize multiple classes of channels defined for forward transmission. A traffic channel is for one or two way communication of information between a remote unit and a base station and is uniquely allocated for communications to and from  
30 the remote unit. The information includes primary traffic, secondary traffic, and signaling traffic. As described in IS-95C, the transmission rate of this channel may vary dynamically. Additionally, soft handoff (simultaneous communication utilizing more than one traffic channel circuit) is supported utilizing traffic channel circuitry 203. Pilot channel circuitry 205 is utilized to broadcast a pilot

- 7 -

channel from base station 101. Such a pilot channel is utilized to provide timing and phase synchronization to aid in subsequent demodulation of a transmitted signal. In the preferred embodiment the pilot channel differs from the pilot described in IS-95C section 7.1.3.2 in that it is time multiplexed with the data channels using the time-division multiplex circuitry 209. Other channel circuitry 206 comprises all other channels utilized by base station 101 such as paging channels, dedicated data channels, access channels, . . . , etc.

FIG. 2 also illustrates detail of the traffic channel circuitry 203 in accordance with the preferred embodiment of the present invention. In the preferred embodiment of the present invention modulator 320 is utilized by all base station channel circuitry except for pilot channel circuitry 205. During operation, signal 310 (traffic channel data bits) is received by the forward error control circuitry (e.g. a convolutional or block or turbo encoder) 312 at a particular bit rate (e.g., 9.6 kbit/second). Input traffic channel data bits 310 typically include voice converted to data by a vocoder, pure data, or a combination of the two types of data. The error control circuitry 312 encodes input data bits 310 into data symbols at a fixed encoding rate with an encoding algorithm that facilitates subsequent maximum likelihood decoding of the data symbols into data bits (e.g. convolutional or block coding algorithms). For example, convolutional encoder 312 encodes input data bits 310 (received at a rate of 9.6 kbit/second) at a fixed encoding rate of one data bit to two data symbols (i.e., rate 1/2) such that convolutional encoder 312 outputs data symbols 313 at a 19.2 ksymbol/second rate.

Data symbols 313 are then input into symbol interleaver 316. Interleaver 316 time interleaves the input data symbols 313 at the symbol level. For example, in interleaver 316, data symbols 313 may be individually input into a matrix which defines a predetermined size block of data symbols 313. Data symbols 313 are input into locations within the matrix so that the matrix is filled in a column by column manner. Data symbols 313 are individually output from locations within the matrix so that the matrix is emptied in a row by row manner. Other symbol interleaver technologies are also possible (e.g. convolutional or pseudo-random interleavers). Typically, the matrix is a square matrix having a number of rows equal to the number of columns; however, other matrix forms can be chosen to increase the output interleaving distance between the consecutively input non-

interleaved data symbols. Interleaved data symbols 318 are output by interleaver 316 at the same data symbol rate that they were input (e.g., 19.2 ksymbol/second). The predetermined size of the block of data symbols defined by the matrix is derived from the maximum number of data symbols which can be transmitted at a  
5 predetermined symbol rate within a predetermined length transmission block. For example, if the predetermined length of the transmission block is 20 milliseconds, then the predetermined size of the block of data symbols is 19.2 ksymbol/second times 20 milliseconds which equals 384 data symbols which defines a 16 by 24 matrix.

10 Interleaved data symbols 318 are input to modulator 320. In the preferred embodiment of the present invention modulator 320 is an orthogonal encoder that modulo 2 adds an orthogonal code (e.g., a 64-ary Walsh code) to each interleaved data symbol 318. For example, in 64-ary orthogonal encoding, interleaved data symbols 318 are each replaced (or spread) by a 64 symbol (chip) orthogonal code  
15 or its inverse. These 64 orthogonal codes preferably correspond to Walsh codes from a 64 by 64 Hadamard matrix wherein a Walsh code is a single row or column of the matrix. Orthogonal encoder 320 repetitively outputs a Walsh code or its inverse having a length of 64 chips 324 which corresponds to input data symbol 318 at a fixed symbol rate (e.g., 19.2 ksymbol/second). The sequence of Walsh codes (each comprising 64 chips) is a direct-sequence spread spectrum modulated  
20 waveform. The spreading code utilized by modulator 320 is a channel (when multiple orthogonal data channels are assigned to a specific user) or user specific sequence of symbols or unique user code which is output at a fixed chip rate (e.g., 1.228 Mchip/second). The present invention is also applicable to other direct-  
25 sequence spread spectrum systems where the output of modulator 320 is any other possibly non-spread waveform (e.g. any phase shift keyed waveform). In some of these applications the multiple-access capability of direct-sequence spread spectrum is not utilized. In some cases the direct-sequence spreading modulation is performed by modulator 214 rather than modulator 320.

30 Following modulation by modulator 320, the outputs 324 and the outputs of the other channel circuitry 206 are linearly summed by summer 207 as shown. After summation the output of summer 207 is direct sequence spread by the scrambling code modulator 214. The scrambling modulation is optional when modulator 320 is itself an orthogonal direct-sequence spreading function (e.g. as

described in IS-95) but is required when modulator 320 is a conventional non-spreading modulator.

At this point spread sequence 212 enters a second interleaver (chip interleaver 208). Interleaver 208 interleaves the input chips at the chip level. In  
5 interleaver 208, chips are individually input into a matrix which defines a predetermined size block of chips. For example, the chips are input into locations within the matrix so that the matrix is filled in a column by column manner. Chips are individually output from locations within the matrix so that the matrix is emptied in a row by row manner. Spreading code chips may also be interleaved in  
10 small groups (e.g. 8-bit words) rather than individual chips. Other interleaver technologies are possible for use with this invention (e.g. convolutional or pseudo-random interleavers). In the preferred embodiment of the present invention the matrix is a rectangular block which has 1416 rows and 64 columns; however, other matrix forms can be chosen to increase the output interleaving distance  
15 between the consecutively input non-interleaved chips. Interleaved chips are output by interleaver 208 at the same chip rate that they were input (e.g., 1.228 Mchip/second). The interleaved chip stream is then time-division multiplexed with the pilot channel signal 218 by the time-division multiplex circuitry 209. The output of 209 is input to the QPSK modulator circuitry 211 where it is bandpass  
20 filtered, translated to an RF frequency, amplified, filtered and radiated via downlink signal 116 to complete transmission of the channel data bits 310.

By interleaving spread data at the chip level, an improvement in the quality of the demodulated signal can be achieved. In particular, transmission quality over a flat fading channel is improved due to the increased time diversity achieved  
25 through chip interleaving. This chip level time diversity supplements the symbol level time diversity already available through the symbol interleaver and the forward error control scheme. Benefits are also achieved in multipath fading (i.e. non-flat fading) although in these cases other types of diversity are possible. The benefit of chip interleaving is particularly important when the spreading  
30 modulation is itself a coded modulation where, for example, information is transmitted by the selection of a set of  $n$  orthogonal codes from a larger set  $N$  of orthogonal codes. Benefits are achieved in spite of the fact that chip interleaving degrades the orthogonality of the spreading code sets.

FIG. 3 is a flow chart showing operation of base station 101 in accordance

-10-

with the preferred embodiment of the present invention. The logic flow begins at step 1 where signal 310 (traffic channel data bits) is received by the forward error control circuitry (e.g. a convolutional or block or turbo encoder) 312 at a particular bit rate (e.g., 9.6 kbit/second). Next, at step 2 the convolutionally encoded symbols are interleaved by interleaver 316. At step 3, the interleaved symbols are spread by an orthogonal code by modulator 320. At step 4 further processing takes place (i.e., summing by summer 207 and scrambling modulation by modulator 320). At step 5, the spread symbols are interleaved at the chip level by chip interleaver 208. Finally, at step 6 the interleaved chip stream is then time-division multiplexed with the pilot channel signal 218 by the time-division multiplex circuitry 209. The output of 209 is input to the QPSK modulator circuitry 211 where it is bandpass filtered, translated to an RF frequency, amplified, filtered and radiated via downlink signal 116 to complete transmission of the channel data bits 310.

The descriptions of the invention, the specific details, and the drawings mentioned above, are not meant to limit the scope of the present invention. For example, in addition to interleaving at the chip-level during downlink transmission, de-interleaving at the chip level will be required by remote unit 113. FIG. 4 shows a block diagram of remote unit 113 in accordance with the preferred embodiment of the present invention. As shown, remote unit 113 comprises chip de-interleaver 405. During operation of remote unit 113, downlink signal 116 is received and demodulated by demodulator 401. The receive signal processing may optionally include equalization circuitry which may further improve performance via appropriate gain modification of the received chips. The resulting signal is de-multiplexed by de-multiplexer 403. The chip stream exiting de-multiplexer 403 enters de-interleaver 405 where the chip stream is de-interleaved. The resulting, de-interleaved chip stream is then processed by other channel circuitry 407 in well known manners (including a second de-interleaving operation at the symbol level) to complete reception of downlink communication signal 116. It is the intent of the inventors that various modifications can be made to the present invention without varying from the spirit and scope of the invention, and it is intended that all such modifications come within the scope of the following claims and their equivalents.

-11-

## Claims

1. A method for interleaving in a spread-spectrum communication system, the method comprising the steps of:
  - 5 receiving a first set of data at a first data rate;
  - performing a first interleaving of the first set of data to produce interleaved symbols;
  - spreading the interleaved symbols with a spreading code whose data rate is greater than the first data rate to produce spread symbols; and
  - 10 performing a second interleaving of the spread symbols to produce spread symbols interleaved at a chip level.
2. The method of claim 1 wherein the step of receiving the first set of data at a first data rate comprises the step of receiving traffic channel data at the first data rate.
- 15 3. The method of claim 1 wherein the step of spreading the interleaved symbols with the spreading code comprises the step of spreading the interleaved symbols with a Walsh code.
- 20 4. The method of claim 1 wherein the step of performing the second interleaving of the spread symbols comprises the step of performing a second interleaving of the spread symbols at a chip level.
- 25 5. The method of claim 1 further comprising the step of transmitting the spread symbols interleaved at the chip level.
6. An apparatus comprising:
  - 30 a chip interleaver having spread data as an input and outputting interleaved spread data, wherein the interleaved spread data is interleaved at a chip level.
7. The apparatus of claim 6 further comprising:
  - a symbol interleaver having symbols as an input and outputting interleaved symbols; and

-12-

a modulator, having the interleaved symbols as an input and outputting spread data.

8. In a communication system where spread data is interleaved at a chip level and  
5 then transmitted, a method comprising the steps of:

receiving the spread data that is interleaved at the chip level; and

de-interleaving at the chip level, the spread data interleaved at the chip  
level.

10 9. An apparatus comprising:

a chip de-interleaver having spread data as an input, wherein the spread  
data is interleaved at a chip level, wherein the chip de-interleaver outputs de-  
interleaved spread data.

15

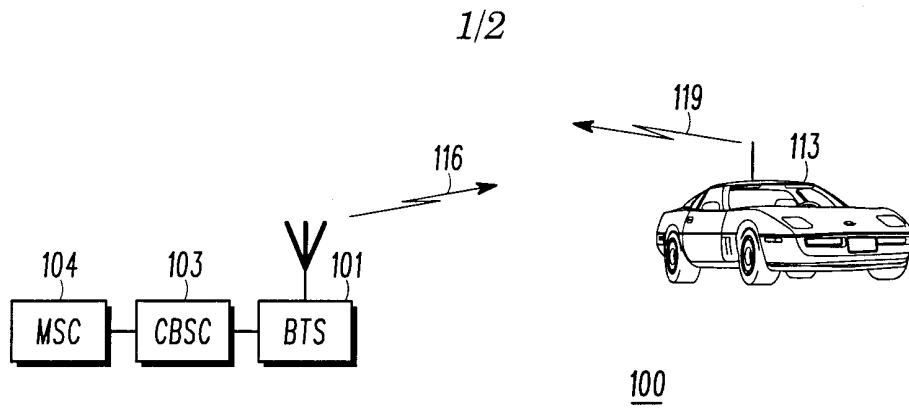

FIG. 1

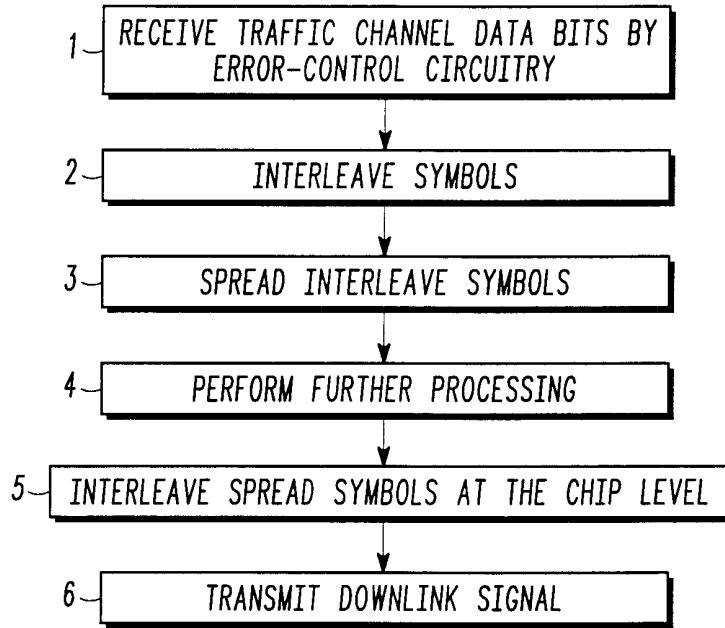

FIG. 3

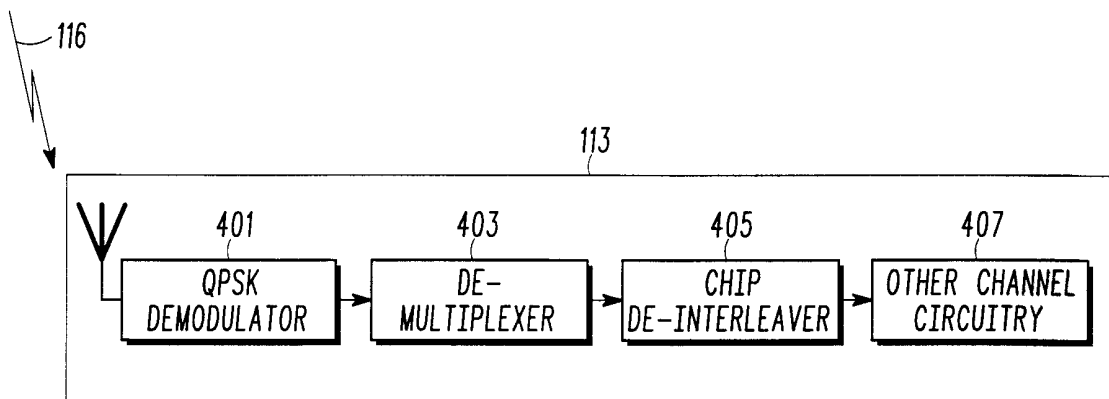

FIG. 4

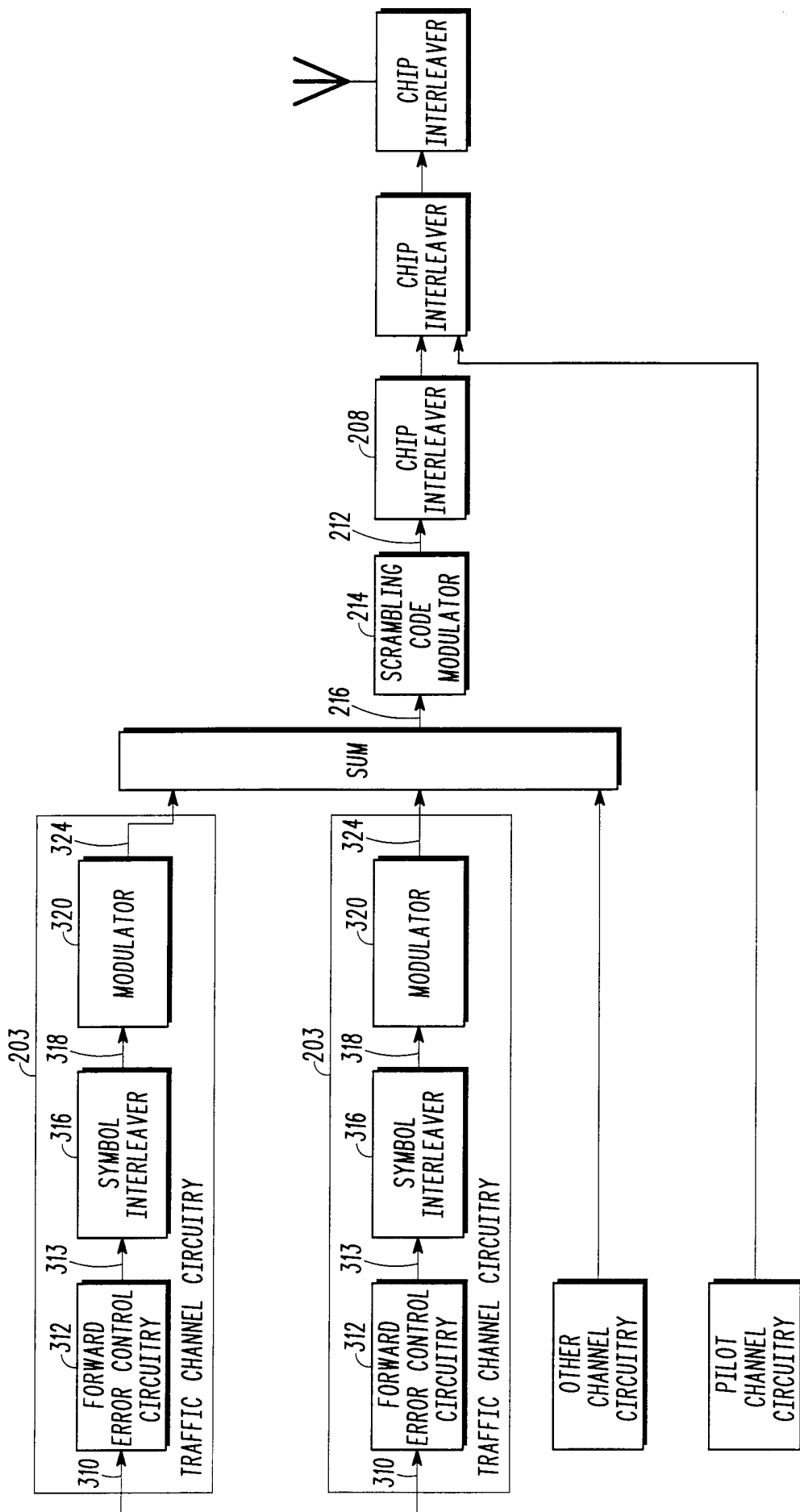
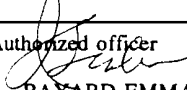

FIG. 2

## INTERNATIONAL SEARCH REPORT

International application No.  
PCT/US00/06028

<b>A. CLASSIFICATION OF SUBJECT MATTER</b>		
IPC(7) :HO4K 1/00; HO4B 7/00 US CL :375/206, 347; 370/342, 536 According to International Patent Classification (IPC) or to both national classification and IPC		
<b>B. FIELDS SEARCHED</b>		
Minimum documentation searched (classification system followed by classification symbols) U.S. : 375/206, 347, 130, 135, 136, 139, 146, 147, 295; 370/342, 536, 335, 320, 441, 479		
Documentation searched other than minimum documentation to the extent that such documents are included in the fields searched		
Electronic data base consulted during the international search (name of data base and, where practicable, search terms used) EAST AND WEST		
<b>C. DOCUMENTS CONSIDERED TO BE RELEVANT</b>		
Category*	Citation of document, with indication, where appropriate, of the relevant passages	Relevant to claim No.
Y,P	US 6,018,545 A (FUKUMASA et al) 25 JANUARY 2000 SEE FIGURES 4,13-16 AND COL.5, LINES 61-67 AND COL.6, LINES 1-30 AND COL.10, LINES 55-67 AND COL.11, LINES 20-35 AND COL.13, LINES 45-67; FIGURES 41, 3-16 AND COL. 5, LINES 50-67 AND COL. 16, LINES 15-67 AND COL. 11, LINES 36-67 AND COL. 13, LINES 55-67.	1-6
X,P		7-15
Y	US 5,771,229 A (GAVRILOVICH et al) 23 JUNE 1998 SEE FIGURE 2 AND COL.6, LINES 40-67 AND COL.7-COL.9.	1-15
<input type="checkbox"/> Further documents are listed in the continuation of Box C. <input type="checkbox"/> See patent family annex.		
*A*	Special categories of cited documents: document defining the general state of the art which is not considered to be of particular relevance	*T* later document published after the international filing date or priority date and not in conflict with the application but cited to understand the principle or theory underlying the invention
*E*	earlier document published on or after the international filing date	*X* document of particular relevance; the claimed invention cannot be considered novel or cannot be considered to involve an inventive step when the document is taken alone
*L*	document which may throw doubts on priority claim(s) or which is cited to establish the publication date of another citation or other special reason (as specified)	*Y* document of particular relevance; the claimed invention cannot be considered to involve an inventive step when the document is combined with one or more other such documents, such combination being obvious to a person skilled in the art
*O*	document referring to an oral disclosure, use, exhibition or other means	*G* document member of the same patent family
*P*	document published prior to the international filing date but later than the priority date claimed	
Date of the actual completion of the international search	Date of mailing of the international search report	
18 MAY 2000	19 JUL 2000	
Name and mailing address of the ISA/US Commissioner of Patents and Trademarks Box PCT Washington, D.C. 20231 Facsimile No. (703) 305-3230	Authorized officer  BAYARD EMMANUEL Telephone No. (703) 308-9573	