



(72) LAFOND, Danielle, CA

(71) LABPLAS INC., CA

(51) Int.Cl.<sup>6</sup> B01F 13/00, G01N 1/38

(54) **MELANGEUR DE CONTENU DE SAC**

(54) **DEVICE FOR BLENDING CONTENTS OF A BAG**

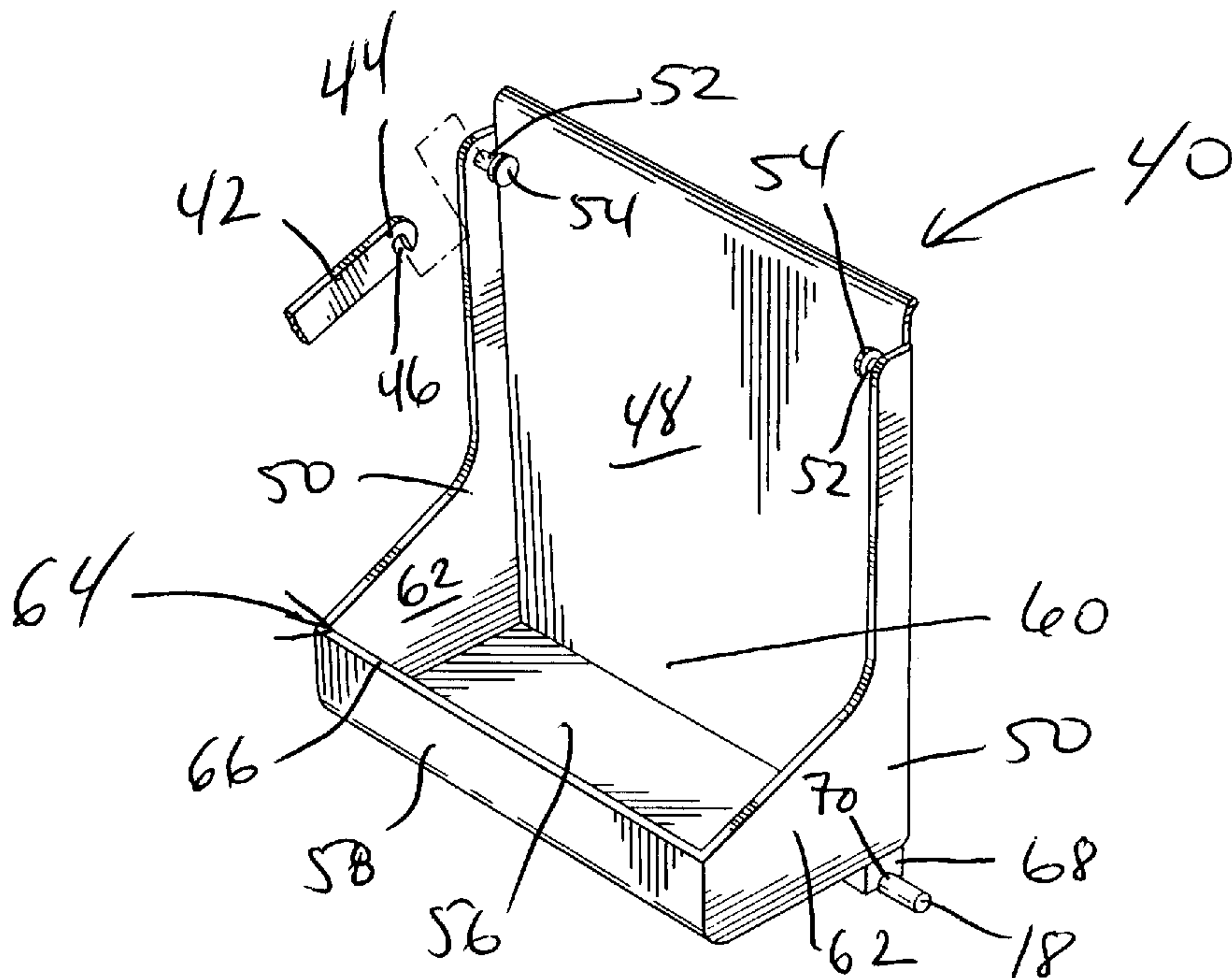

(57) A blending device for mixing the contents of a plastic bag comprises a casing defining a mixing chamber in which are disposed paddles or the like for acting on the bag and mix the contents thereof, and having a pivotable door for providing access to the chamber and positioning a bag and its contents in this chamber. The door includes a lower container which extends inwardly towards the casing such as to be located in the casing's mixing chamber when the door is a closed position such that spillage resulting from a rupture of the bag in the blending machine is collected in the door's bottom container. Preferably, the door can be easily, completely disconnected from the casing for facilitating the cleaning thereof, for instance following a collection by the container thereof of a spillage.

ABSTRACT

5           A blending device for mixing the contents of a  
plastic bag comprises a casing defining a mixing chamber  
in which are disposed paddles or the like for acting on  
the bag and mix the contents thereof, and having a  
pivotal door for providing access to the chamber and  
10 positioning a bag and its contents in this chamber. The  
door includes a lower container which extends inwardly  
towards the casing such as to be located in the casing's  
mixing chamber when the door is a closed position such  
that spillage resulting from a rupture of the bag in the  
15 blending machine is collected in the door's bottom  
container. Preferably, the door can be easily, completely  
disconnected from the casing for facilitating the  
cleaning thereof, for instance following a collection by  
the container thereof of a spillage.

## DEVICE FOR BLENDING CONTENTS OF A BAG

BACKGROUND OF THE INVENTION1. Field of the Invention

5           The present invention relates to devices for blending, mixing and/or homogenizing the contents of a bag and, more particularly of a steroplastic bag holding clinical samples, for instance used in laboratories, in hospitals, in the food industry, etc.

10           2. Description of the Prior Art

          It is well known to provide sterile plastic bags for holding samples, such as the plastic bag disclosed in U.S. Patent No. 5,564,829 issued on October 15, 1996 to Lafond. In this patent a disposable  
15 sterile plastic bag B is disclosed for holding samples in blenders during the mixing thereof, the bag B comprising a two-ply sheet flexible material integrally joined at opposed side edges thereof and joined at the upper and lower ends thereof respectively by upper and lower heat  
20 seals with a sealed sample receiving chamber being defined between the two plastic sheets inwardly of the bag's side edges and upper and lower sealed ends. Inwardly of the upper seal, there is defined a tear-off line 20 transversely across the two sheets and parallelly  
25 to the upper seal 16 thereby forming a detachable strip 24 outwardly of the tear-off line 20. When the sample is ready to be introduced in the bag B, the strip 24 is removed from the bag B by pulling it so as to cause rupture of the two sheets at the tear-off 20. The bag's  
30 chamber is thus sterile when the sample is introduced therein and the bag B and its contents can then be inserted in a blending machine, also called a homogenizer or a mixer. The bag's sterility does not depend on how the bag is packaged or on the integrity of the  
35 packaging's seal as the bag is itself sterile until the strip 24 is removed therefrom, that is until the bag is ready to be used.

Generally, commercial homogenizers or blenders used in laboratories to mix samples include a casing having a door which is pivoted to the casing and which, when open, reveal a chamber in the casing. In this chamber, there is provided paddles which are adapted to be repeatedly displaced by a motor. When the contents of a bag are to be mixed or blended, the door of the homogenizer is opened and the plastic bag and its contents are inserted into the homogenizer's chamber and the door is then closed such as to trap the upper end of the bag between the door and the casing while a lower portion of the bag and its contents are located in the chamber. The door, when closed, traps the upper end of the bag and thus firmly secures the same in a generally upright position in the homogenizer. The homogenizer then switch on and the paddles, in a reciprocating movement, repeatedly pound the plastic bag and thus cause its contents to mix. After the homogenizer has been switched off, the door is opened and the bag is removed therefrom with the blended sample being now appropriately mixed and, for instance, ready for analysis.

In known homogenizers or blenders, the pivotable door cannot be removed from the rest of the blender. Furthermore, any rupture of the bag in the blender causes its contents to flow into the chamber of the blender and possibly onto the surface on which the homogenizer rests. This requires that the blender be extensively cleaned and there are some contamination risks in the laboratory.

#### 30 SUMMARY OF THE INVENTION

It is therefore an aim of the present invention to provide an improved device for mixing or blending the contents of a bag and having a pivotable door which can be easily removed from the remainder of the device.

35 It is also an aim of the present invention to provide an improved device for blending or mixing the contents of a bag and comprising a pivotable door having

a container located below the bag, when the latter is secured in the device, such that if the bag ruptures, its contents find their way into the door's container.

Therefore, in accordance with the present invention, there is provided a blending device for mixing contents of a bag, comprising a casing defining a chamber and comprising a mixer means and a door, wherein when a bag is at least partly positioned in said chamber and said door is closed, said mixer may be operated to act on the bag and cause a content thereof to be mixed, said door defining a collection container adapted to extend in said chamber when said door is closed and to extend under the bag, whereby some of the contents of the bag spilling therefrom while the bag is in said blending device and said door is closed will be collected by said container.

Also in accordance with the present invention, there is provided a blending device for mixing contents of a bag, comprising a casing defining a chamber and comprising a mixer means and a door, wherein when a bag is at least partly positioned in said chamber and said door is closed, said mixer may be operated to act on the bag and cause a content thereof to be mixed, said door being removably connected to said casing.

#### BRIEF DESCRIPTION OF THE DRAWINGS

Having thus generally described the nature of the invention, reference will now be made to the accompanying drawings, showing by way of illustration a preferred embodiment thereof, and in which:

Fig. 1 is a perspective view of a conventional device for blending the contents of a bag with a pivotable door thereof being shown in open position with a bag being illustrated at it is positioned in the blending device;

Fig. 2 is perspective view similar to Fig. 1 but showing the conventional blending device with its door in a closed position thereof, an upper portion of the bag extending outwardly of the blending device with a

lower portion thereof and the bag's contents being located in the blending machine;

Fig. 3 is rear perspective view of the door of the conventional blending device of Fig. 1; and

5 Fig. 4 is rear perspective door in accordance with the present invention for use in a blending machine also in accordance with the present invention.

DESCRIPTION OF THE PREFERRED EMBODIMENTS

Figs. 1 and 2 illustrate a blending device D of the prior art and comprising a casing 10 defining an inner chamber 12 in which are located a pair of paddles 14. The paddles 14 are actuated such as to displace in a reciprocating manner for reasons which will become apparent hereinbelow. Access to the chamber 12 is provided by a door 16 which is pivotally mounted at its bottom around a rod 18, as seen in Fig. 3. The upper end of the door 16 is pivotally mounted to the casing 12 by way of a pair of articulated linkages 20 which allow the door to be pivoted about the rod 18 between open and closed positions as shown respectively in Figs. 1 and 2. When the door 16 is open, a flexible bag B may be introduced in the chamber 12, between the paddles 14 and the door 16, as well illustrated in Fig. 1. The bag B has a content C which is located opposite the paddles 14. When the door 16 is closed, as in Fig. 2, an upper portion 22 of the bag B is trapped between the door 16 and the casing 10 with a lower portion 24 of the bag B (see Fig. 1) being located in the chamber 12. Therefore, switching on the blending device D results in the displacement of the paddles 14 which repeatedly pound on the bag B such as to mix the contents C thereof.

As seen in Fig. 3, the door 16 is fixedly mounted to the linkages 20 (only part of one of which is shown in Fig. 3) by way of a pin 26, or rivet, which engage a hole 28 defined in the linkage 20 and which also engages a hole 30 defined in one of the two side flanges 32 of the door 16. The lower end of the door 16 defines a

fold 34 which engages by gravity the rod 18. It is therefore possible to displace the door 16 and the linkages 20 pivotally attached thereto in such a manner as to raise the door 16 out of engagement with the rod 18 with the door 16 being then pivoted above the blending device. In this position, which is not illustrated, easy access is provided to the paddles 14 and to the blending chamber 12 and this also allows the blending device D to be easily cleaned.

It must be noted that the above conventional blending device D becomes dirtied and possibly contaminated by any accidental spillage of the contents C of the bag B while the latter is in the blending device D. Indeed, if for instance during the blending of the contents C of the bag B under the repeated action of the reciprocating paddles 14, the bag B tears or ruptures, its contents C, or a portion thereof, may spill in the blending device D and also possibly on the surface onto rests the blending device D and this may cause the contamination of the blending device D and/or the room in which it is located. Furthermore, the door 16 cannot be completely detached from the casing 10.

Therefore, in accordance with the present invention, the blending device D of Figs. 1 and 2 has been modified and, more particularly, the door 16 and the linkages 20 of the conventional blending device D have been replaced by a new door 40 (made of stainless steel) and associated linkages 42. The each linkage 42 defines at its end 44 which connects to the door 40 a notch such that the linkage end 44 has the form of a hook open at its bottom. The door 40 defines a front wall 48 and a pair of side walls 50 extending inwardly, that is towards the casing 10, from the front wall 48. It must be noted that Fig. 4, as in Fig. 3, is a perspective which considers the door 40 from the inside, that is outwardly from the casing 10. At the upper end of each side wall 50, there extends inwardly and horizontally a pin 52

provided with a head 54 which is spaced apart from the side wall 50. Therefore, the cylindrical stem of the pin 52 located between the side wall 50 of the door 40 and the head 54 of the pin 52 can be received in notch 46 of the linkage 42, such that the linkages 42 can be selectively disconnected from the pins 52 and thus from the door 40.

The door 40 also includes a bottom wall 56 and a rear wall 58 which, with a lower portion 60 of the front wall 48 and lower portions 62 of the side walls 50, define a collection container 64 at the lower end of the door 40. When the bag B is in the blending device adapted with the present door 40 and with this door 40 being in a closed position similar to that shown in Fig. 2, the lower portion of the bag B and its contents C located in the mixing chamber 12 of the blending device are located above the bottom wall 56 of the container 64. Obviously, the rear wall 58 of the door 40 is positioned and dimensioned with respect to the paddles 14 such that the paddles 14 displaced above an upper edge 66 of the rear wall 58 such that the rear wall 58 does not interfere with the pounding action of the paddles 14 on the bag B. Obviously, it may be the paddles 14 which are shortened with respect to the prior art paddles in order to be clear of the rear wall 58 of the door 40 of the present invention.

An elongated nylon member 68 is secured to the underside of the bottom wall 56 and defines on a lower surface thereof a semi-circular trough 70 which engages the rod 18 fixed to the casing 10. As for the door 16 of Figs. 1 to 3, the rod 18, albeit shown in both Figs. 3 and 4, is not part of the door 40 (and of the door 16) as it is fixedly mounted to the casing 10, but is shown herein in Figs. 3 and 4 for clarity purposes of the engagement of the doors 16 and 40 to this support rod 18. The present door 40 engages by gravity the support rod 18 such that the door 40 can be completely disconnect from

the casing 10 by disengaging the linkages 42 from the pins 52 of the door 40 and by elevating the door 40 and thus elongated member 68 out of engagement with the support rod 18.

5                   Therefore, with the door 40 of the present invention provided on an otherwise substantially conventional blending device D, any spillage of the contents C of the bag B while the latter is in the blending device is collected in the container 64 and thus  
10 does not reach the casing 10 itself and its chamber 12, nor does such a spillage reach the support surface onto which rests the blending device. Following such a spillage, the present door 40 can be disconnect, as described hereinabove, from the casing 10 and completely  
15 detached from the remainder of the blending device D such that the spillage collected in the container 64 thereof may be disposed of in an appropriate manner without dirtying the blending device D nor contaminating the same as well as the room in which the blending device is being  
20 used. The removability of the door 40 facilitates the cleaning and sterilization of the door 40, for instance following a spillage from a bag B in the container 64 thereof, but the present container 64 could also embodied in a door which cannot be completely disconnected from  
25 the casing of the blending device; in such a case, the spillage collected in the container 64 could be removed by other means, such as by suction with the container 64 being then cleaned appropriately while remaining connected to the casing 10. The longitudinal and  
30 transversal dimensions of the container 64 are preferably as such that most, if not all at least in some cases, spillage from the bag B is collected in the container 64.

The embodiments of the invention in which an exclusive property or privilege is claimed are defined as follows:

1. A blending device for mixing contents of a bag,  
5 comprising a casing defining a chamber and comprising a mixer means and a door, wherein when a bag is at least partly positioned in said chamber and said door is closed, said mixer may be operated to act on the bag and cause a content thereof to be mixed, said door defining a  
10 collection container adapted to extend in said chamber when said door is closed and to extend under the bag, whereby some of the contents of the bag spilling therefrom while the bag is in said blending device and said door is closed will be collected by said container.  
15
2. A blending device as defined in Claim 1, wherein said door is removably connected to said casing.
3. A blending device as defined in Claim 2, wherein at  
20 least one linkage is provided for connecting said casing to said door, said linkage being pivotally mounted to said casing and to said door at opposed first and second ends thereof respectively, and being detachably connected at said second end to an upper end of said door, said  
25 door defining at a lower end thereof a trough adapted to engage a support rod mounted to said casing and being removable therefrom for allowing said door to be disconnected from said casing.
- 30 4. A blending device for mixing contents of a bag, comprising a casing defining a chamber and comprising a mixer means and a door, wherein when a bag is at least partly positioned in said chamber and said door is closed, said mixer may be operated to act on the bag and  
35 cause a content thereof to be mixed, said door being removably connected to said casing.

5. A blending device as defined in Claim 4, wherein at least one linkage is provided for connecting said casing to said door, said linkage being pivotally mounted to said casing and to said door at opposed first and second ends thereof respectively, and being detachably connected at said second end to an upper end of said door, said door defining at a lower end thereof a trough adapted to engage a support rod mounted to said casing and being removable therefrom for allowing said door to be disconnected from said casing.

6. A blending device as defined in Claim 5, wherein said second end defines a notch adapted to engage a pin provided on said door.

15

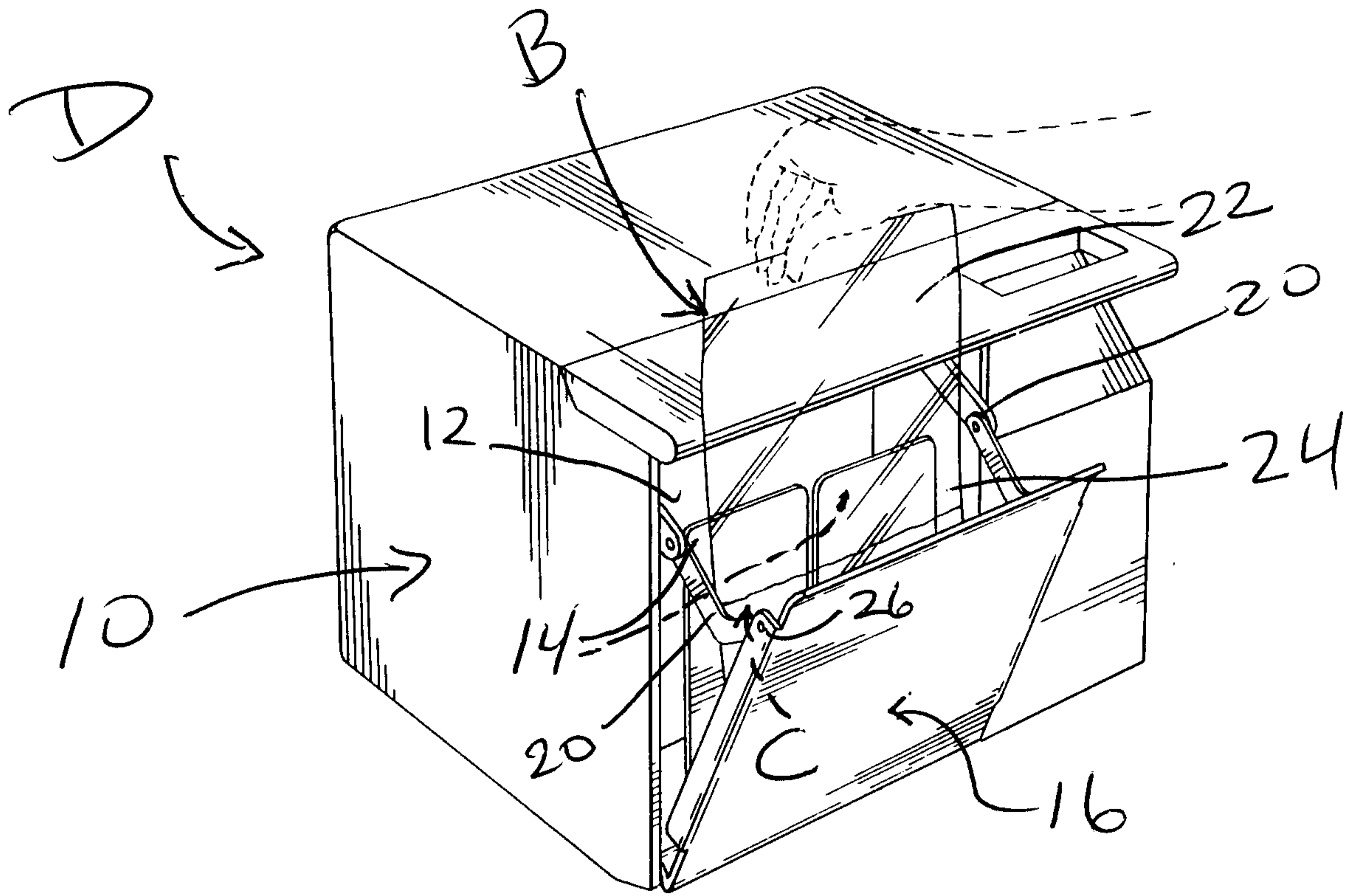

FIG. 1 (PRIOR ART)

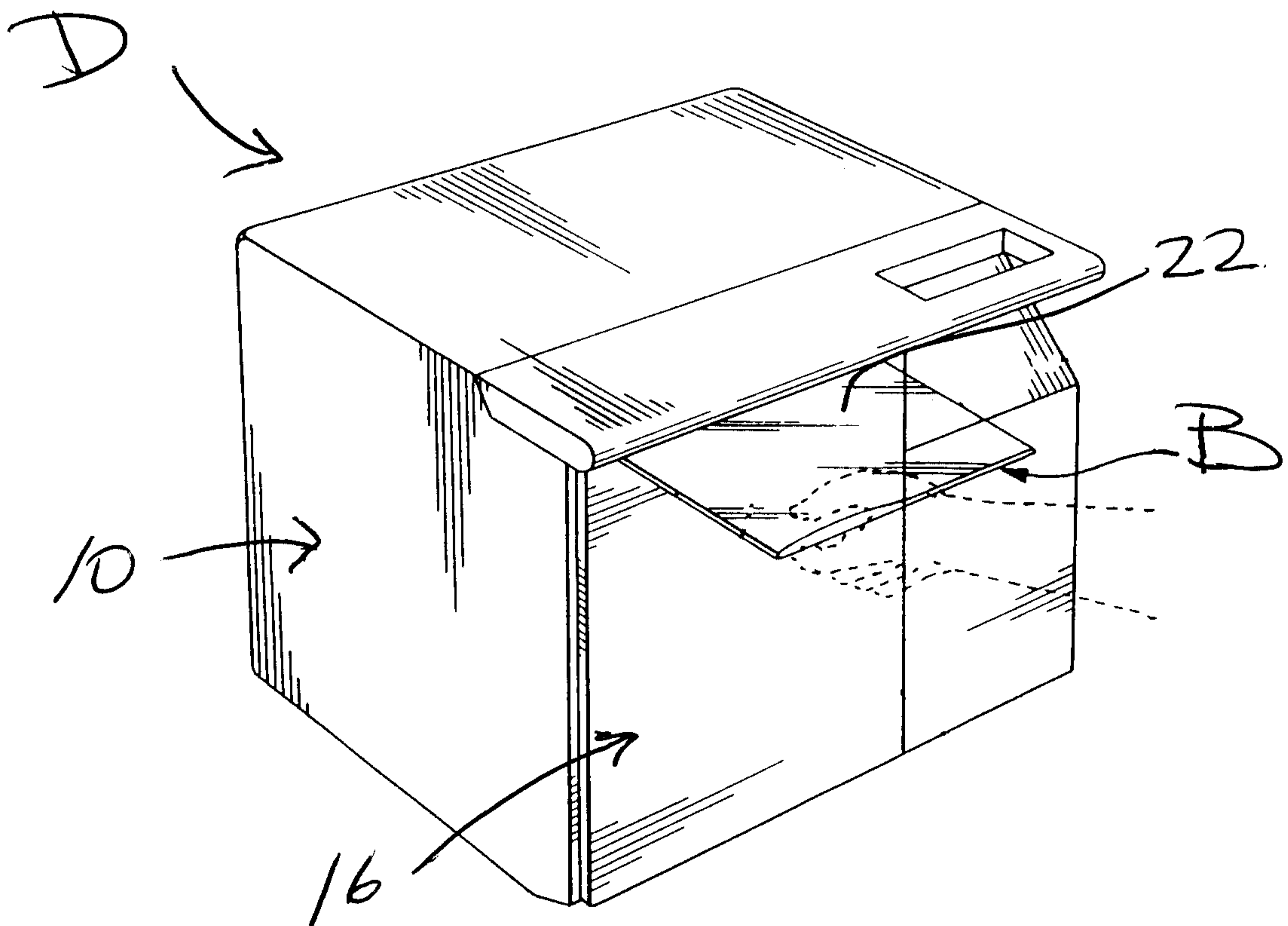

FIG. 2 (PRIOR ART)

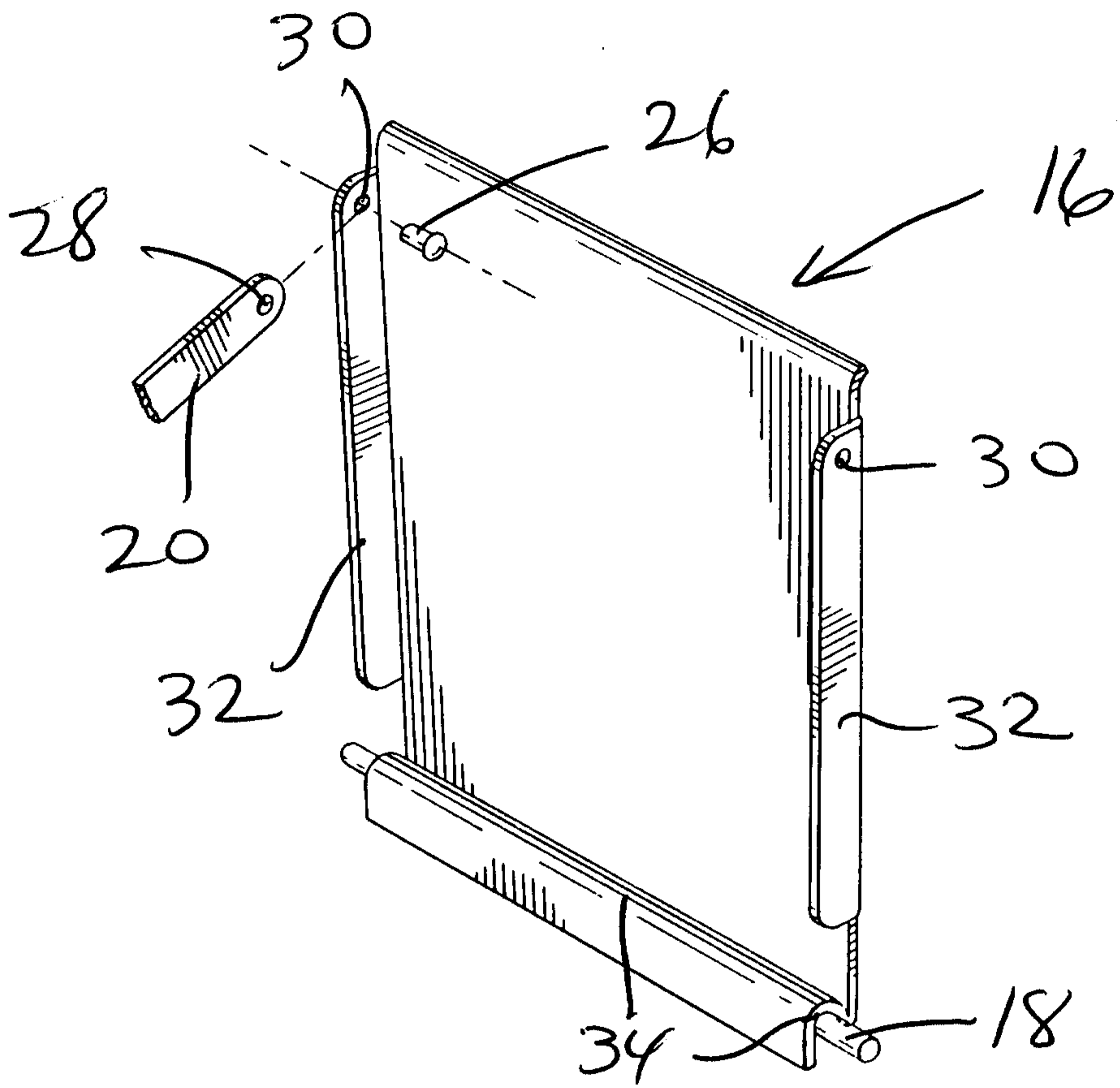

FIG. 3 (PRIOR ART)

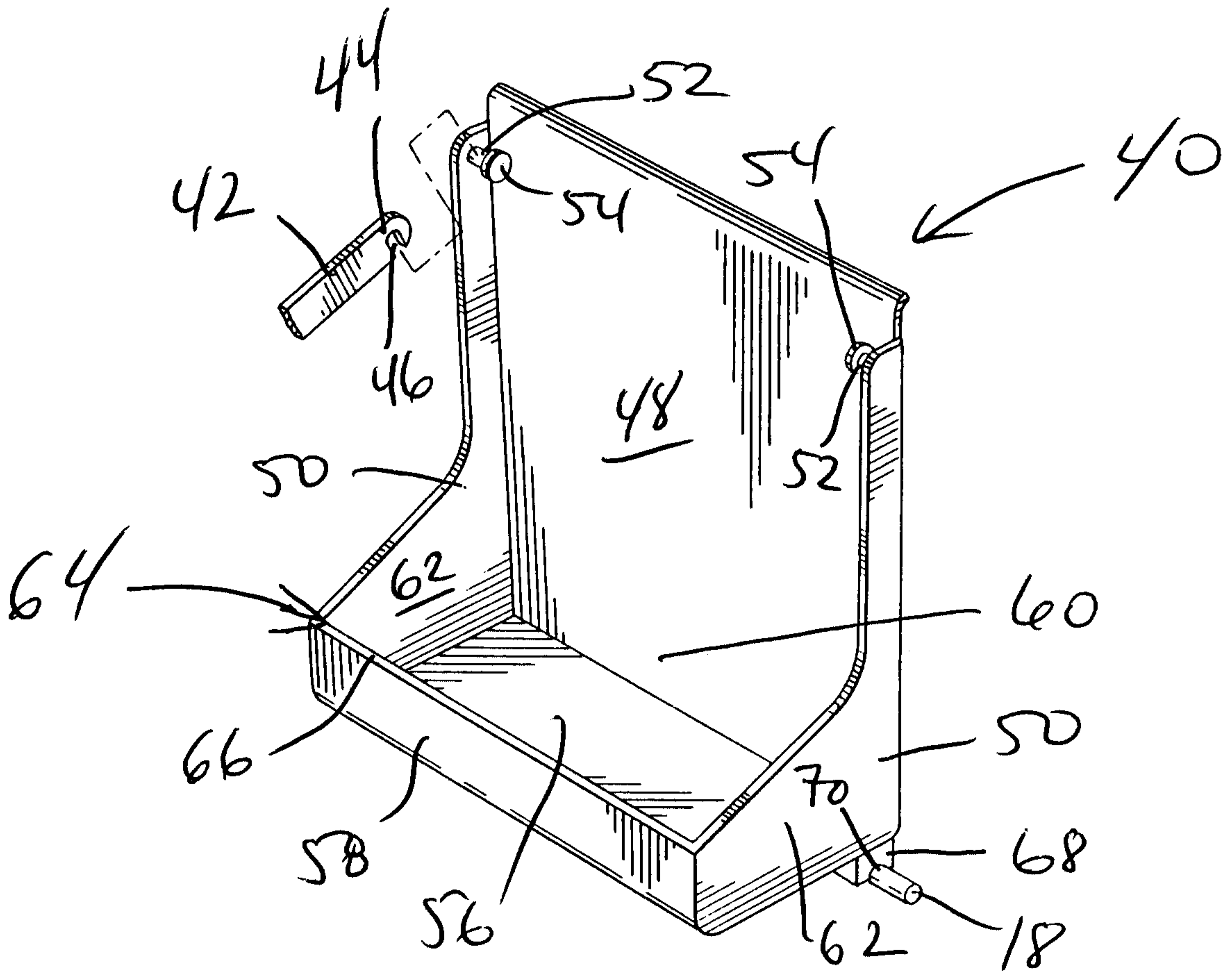

FIG. 4

