



(51) International Patent Classification:

E04B 1/66 (2006.01) *E01C 11/02* (2006.01)
E04G 23/02 (2006.01)

(21) International Application Number:

PCT/IN2019/050473

(22) International Filing Date:

24 June 2019 (24.06.2019)

(25) Filing Language:

English

(26) Publication Language:

English

(30) Priority Data:

201821023592 25 June 2018 (25.06.2018) IN

(72) Inventor; and

(71) Applicant: **TRIVEDI, Anil** [IN/IN]; Raw House No.3, Emerald Chs, Next to D Mart, Thane, Maharashtra 406007 (IN).

(74) Agent: **SINGH, Manisha**; Lexorbis, 606-607, 6th Floor, Gamma Block, Sigma Soft Tech Park No. 7, Whitefield Main Road, Varthur Hobli, Bengaluru, Karnataka 560066 (IN).

(81) Designated States (unless otherwise indicated, for every kind of national protection available): AE, AG, AL, AM, AO, AT, AU, AZ, BA, BB, BG, BH, BN, BR, BW, BY, BZ,

CA, CH, CL, CN, CO, CR, CU, CZ, DE, DJ, DK, DM, DO, DZ, EC, EE, EG, ES, FI, GB, GD, GE, GH, GM, GT, HN, HR, HU, ID, IL, IN, IR, IS, JO, JP, KE, KG, KH, KN, KP, KR, KW, KZ, LA, LC, LK, LR, LS, LU, LY, MA, MD, ME, MG, MK, MN, MW, MX, MY, MZ, NA, NG, NI, NO, NZ, OM, PA, PE, PG, PH, PL, PT, QA, RO, RS, RU, RW, SA, SC, SD, SE, SG, SK, SL, SM, ST, SV, SY, TH, TJ, TM, TN, TR, TT, TZ, UA, UG, US, UZ, VC, VN, ZA, ZM, ZW.

(84) Designated States (unless otherwise indicated, for every kind of regional protection available): ARIPO (BW, GH, GM, KE, LR, LS, MW, MZ, NA, RW, SD, SL, ST, SZ, TZ, UG, ZM, ZW), Eurasian (AM, AZ, BY, KG, KZ, RU, TJ, TM), European (AL, AT, BE, BG, CH, CY, CZ, DE, DK, EE, ES, FI, FR, GB, GR, HR, HU, IE, IS, IT, LT, LU, LV, MC, MK, MT, NL, NO, PL, PT, RO, RS, SE, SI, SK, SM, TR), OAPI (BF, BJ, CF, CG, CI, CM, GA, GN, GQ, GW, KM, ML, MR, NE, SN, TD, TG).

Declarations under Rule 4.17:

— as to the applicant's entitlement to claim the priority of the earlier application (Rule 4.17(iii))

(54) Title: A SEALING ELEMENT FOR SEALING A GAP BETWEEN CONCRETE PAVEMENTS/STRUCTURES

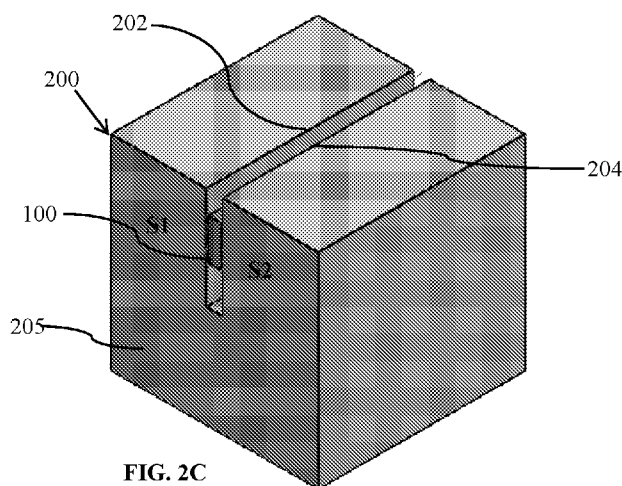

FIG. 2C

(57) Abstract: A sealing element (100) for sealing a gap (205) between concrete pavements (S1, S2) is disclosed. The sealing element (100) comprises a housing (105) provided in a solid structure. The sealing element (100) comprises a plurality of fins (110) coupled to the housing (105) at outer surface. The housing (105) is compressed and placed between concrete pavements (S1, S2) having a gap (205) may be in between a range of 1mm to 5mm. The housing (105) expands outward and the housing (105) is held against walls (202, 204) of the concrete pavements (S1, S2). The plurality of fins grips are held against walls (202, 204) of the concrete pavements (S1, S2).



Published:

- *with international search report (Art. 21(3))*
- *in black and white; the international application as filed contained color or greyscale and is available for download from PATENTSCOPE*

**A SEALING ELEMENT FOR SEALING A GAP BETWEEN CONCRETE
PAVEMENTS/STRUCTURES**

FIELD OF INVENTION

5

[01] The present disclosure relates to a sealing element. More specifically, the present disclosure relates to the sealing element provided in a gap between concrete pavements/panels/structures.

10

BACKGROUND

[02] It is known concrete is used to lay structures, i.e., concrete structures/panels such as pavements, roads, parking lot, airport runways, taxiways, proms, and the like. The concrete structures undergo a lot of stress due to temperature, shrinkage, creep and seismic conditions. As a result, the concrete structures may change its structure, such as the concrete structures may expand or contract. In order to facilitate the changes in the structure of the concrete pavements, generally the concrete pavements are cut to provide a gap. The gap is provided to accommodate changes in the structure.

[03] Due to the environment in which the concrete structures are laid, they are prone to receive debris, water, dust and so on. The debris or water entering the gap may clog and hinder the expansion and contraction of the concrete structures. In order to overcome the problem of debris and water entering the gap provided between the concrete pavements, sealing elements are used.

25

[04] Typically, there are two types of sealing elements. The sealing elements may include liquid sealant and a solid seal. A liquid sealant is commonly used for sealing the gap. However, the liquid sealant has to be heated and then poured into the gap. The liquid sealant is heated at a temperature ranging from 177- 204 degree centigrade for proper sealing. It is important to control the temperature at the time of heating to obtain desired sealant properties. However, that requires trained personnel. Further, the liquid sealants are expensive to repair.

30

[05] In another example, a liquid sealant may also be provided to seal the gap between the concrete pavements. Typically, the liquid sealant is provided as cold pour sealants. The cold pour sealant is provided in a single part, two parts or three parts. The cold pour sealant is obtained by operating one or more processes such as a chemical mixing process, a pouring process, and a curing process. However, these processes require trained personnel to pour the liquid sealant as ambient temperature, substrate moisture, other conditions influence performance of the cold pour sealants.

[06] The solid seal is typically made of rubber or plastic. The solid seal is compressed and inserted in the gap. Generally, the solid seal is provided in a hollow structure.

[07] It should be understood that the liquid sealants and the solid seal are usually provided to seal the gap having a width of 10mm to 12mm. However, the liquid sealants and the solid seal are not suitable for sealing the concrete pavements having a gap less than 5mm.

[08] None of the disclosures in the prior art disclosed a sealant or seal provided to seal the concrete pavements having a gap less than 5mm. It must be understood that it is very difficult to provide a solid seal having a hollow structure that can be compressed and inserted between the concrete pavements having a gap of less than 5mm.

[09] Therefore, there is a need in the art for a sealing element that can be used to insert between the concrete pavements having a gap of less than 5mm.

SUMMARY

[010] This summary is provided to introduce concepts related to a sealing element for sealing a gap between concrete pavements and the concepts are further described below in the detailed description. This summary is not intended to identify essential features of the disclosed subject matter nor is it intended for use in determining or limiting the scope of the disclosed subject matter.

[011] In one aspect of the present disclosure, a sealing element for sealing a gap between concrete pavements is disclosed. The sealing element is made of polymeric materials, such as a plastic. The sealing element comprises a housing and a plurality of fins coupled to an outer surface of the housing. The housing is provided in a solid structure. The housing is compressed and inserted in a gap provided between the concrete pavements. The gap may be between 1mm to 5mm. After insertion, the housing expands toward adjacent walls of the concrete pavements and exerts pressure through the fins against the adjacent walls of the concrete pavement. The fins and the housing of the sealing element, firmly grip with the adjacent walls of the concrete pavement and seal the gap. The sealing element enables to prevent the entry of water, moisture and debris, into the gap.

[012] The above summary is illustrative only and is not intended to be in any way limiting. In addition to the illustrative aspects, example embodiments, and features described above, further aspects, example embodiments, and features will become apparent by reference to the drawings and the following detailed description.

BRIEF DESCRIPTION OF THE FIGURES

[013] These and other features, aspects, and advantages of the example embodiments will become better understood when the following detailed description is read with reference to the accompanying drawings in which like characters represent like parts throughout the drawings, wherein:

[014] FIG. 1A, 1B, and 1C illustrate schematic diagrams of sealing element comprising a plurality of fins in various shapes, in accordance with one embodiment of the present disclosure;

[015] FIG. 1D, 1E, and 1F illustrate schematic diagrams of the sealing element compressed, in accordance with one embodiment of the present disclosure;

[016] FIG. 1G and 1H illustrate a front and a perspective view of the sealing element, respectively, in accordance with one embodiment of the present disclosure;

[017] FIG. 2A illustrates the sealing element placed in axis with a gap provided between
5 concrete pavements, in accordance with one embodiment of the present disclosure;

[018] FIG. 2B illustrates the sealing element placed in the gap provided between the concrete pavements, in accordance with one embodiment of the present disclosure;

10 [019] FIG. 2C illustrates a perspective view of the sealing element placed in the gap provided between the concrete pavements, in accordance with one embodiment of the present disclosure;

[020] FIG. 2D and 2E illustrate schematic diagrams of the concrete pavements having a cut section, in accordance with one embodiment of the present disclosure; and

15

[021] FIG. 2F illustrates a perspective view of the concrete pavement having the cut section provided for placing the sealing element in the gap, in accordance with one embodiment of the present disclosure.

20 Further, skilled artisans will appreciate that elements in the figures are illustrated for simplicity and may not have necessarily been drawn to scale. Furthermore, in terms of the construction of the device, one or more components of the device may have been represented in the figures by conventional symbols, and the figures may show only those specific details that are pertinent to understanding the embodiments of the present invention so as not to obscure the figures with
25 details that will be readily apparent to those of ordinary skill in the art having the benefit of the description herein.

DETAILED DESCRIPTION

30 [022] The terms "comprises", "comprising", or any other variations thereof, are intended to cover a non-exclusive inclusion, such that a process or method that comprises a list of steps does

not include only those steps but may include other steps not expressly listed or inherent to such process or method. Similarly, one or more devices or sub-systems or elements or structures or components preceded by "comprises... a" does not, without more constraints, preclude the existence of other devices or other sub-systems or other elements or other structures or other components or additional devices or additional sub-systems or additional elements or additional structures or additional components. Appearances of the phrase "in an embodiment", "in another embodiment" and similar language throughout this specification may, but do not necessarily, all refer to the same embodiment.

10 [023] In addition to the illustrative aspects, exemplary embodiments, and features described above, further aspects, exemplary embodiments of the present disclosure will become apparent by reference to the drawings and the following detailed description.

[024] Referring to **FIG. 1A**, a sealing element **100** is shown, in accordance with one
15 embodiment of the present disclosure. The sealing element **100** comprises a housing **105**. The housing **105** may be provided in a shape of square, a rectangle, and so on. The housing **105** may be made of an elastomer, a polymeric material, such as a plastic, a rubber, ethylene vinyl acetate, and a combination thereof. The housing **105** comprises a top end **106**, a bottom end **107**, a first side **108**, and a second side **109**. The distance between the top end **106** and the bottom end **107**
20 defines a length of the housing **105**. The distance between the first side **108** and the second side **109** defines a width of the housing **105**.

[025] The housing **105** further comprises a plurality of fins **110** provided at outer surface of the housing **105**. Specifically, the plurality of fins **110** are provided across the length of the housing
25 **105**. In one implementation, the plurality of fins **110** are provided in perpendicular to the first side **108** and the second side **109** of the housing **105**. Further, the plurality of fins **110** are provided in symmetrical at the first side **108** and the second side **109** of the housing **105**. The plurality of fins **110** may be placed at equal distance from one another.

[026] Now referring to **FIG. 1B**, the plurality of fins **110** provided in asymmetrical at the first side **108** and the second side **109** of the housing **105** is shown. As can be seen, the plurality of fins **110** may be placed at varied distance from one another.

5 [027] Now referring to **FIG. 1C**, the plurality of fins **110** provided at an acute angle with respect to the first side **108** and the second side **109** of the housing **105** is shown. In one example, the plurality of fins **110** may be placed at 45 degrees with respect to the first side **108** and the second side **109** of the housing **105**. It should be obvious to a person skilled in the art to place the plurality of fins **110** at equal or varied distance from one another and to position the
10 plurality of fins **110** in a symmetrical or asymmetrical manner as explained above.

[028] Referring to **FIG. 1D**, the housing **105** compressed is shown. It should be understood that width of the housing **105** becomes less than 5mm. In one example, the housing **105** is compressed to have a width of 1mm. In another example, the housing **105** is compressed to have
15 a width of 0.6mm. **FIG. 1D** shows the housing **105** (shown in **FIG. 1A**) compressed which has a width of 1mm. Similarly, **FIG. 1E** is provided to show the housing **105** (shown in **FIG. 1B**) compressed which has a width of 1mm. Further, **FIG. 1F** is provided to show the housing **105** (shown in **FIG. 1C**) compressed which has a width of 1mm.

20 [029] It should be understood that the housing **105** may compressed such that width of the housing **105** prior to compression and after compression can be in the ratio of 10:1. As such, if the width of the housing **105** prior to compression is 6mm, then the width of the housing **105** after compression can be reduced to 0.6mm.

25 [030] Referring to **FIG. 1G**, a front view of the sealing element **100** is shown. In one example, the length of the housing **105** is 10 mm. Further, the width of the housing **105** is 6 mm to 8mm. It should be understood that the width of the housing **105** may be selected in the range of 6mm to 15mm or more. Similarly, the length of the housing **105** may be selected in the range of 6mm to 15mm or more.

30

[031] Now, referring to **FIG. 1H**, a perspective view of the sealing element **100** is shown. The housing **105** of the sealing element **100** is provided in a solid structure is shown. Further, the housing **105** is provided in the shape of rectangle. It should be understood that the shape of the housing **105** could be square, circular and the like.

5

[032] The sealing element **100** can be used to seal a gap provided between concrete pavements. Referring to **FIG. 2A**, the sealing element **100** used with a concrete pavement **200** is shown. As known, the concrete pavement **200** may be separated by a cut as e.g., a first pavement **S1** and a second pavement **S2** having a first wall **202** and a second wall **204**, respectively. The distance
10 between the first wall **202** and the second wall **204** defines a gap **205** provided between the first pavement **S1** and the second pavement **S2** to accommodate changes in the concrete pavement **200** due to expansion and contraction. Generally, the gap **205** is provided having a width of 6 to 10 mm or more and liquid sealants or hollow seal are used to cover the gap **205**. However, due to
15 at least 8mm width, the edges of the first pavement **S1** and the second pavement **S2** may get damaged when vehicles are moving over the concrete pavement **200**. In order to overcome the problem specified above and to increase the life of the concrete pavement **200**, the gap **205** between the first pavement **S1** and the second pavement **S2** may be reduced. For instance, the gap **205** between the first pavement **S1** and the second pavement **S2** may be reduced to 5mm or less.

20

[033] In order to cover the gap **205** of 5mm or less provided between the first pavement **S1** and the second pavement **S2**, the sealing element **100** is used. As can be seen from **FIG. 2A**, the housing **105** having a width e.g., 6mm may be used to insert in the gap **205** provided between the first pavement **S1** and the second pavement **S2**. In one example, the sealing element **100** is
25 inserted using an applicator machine (not shown). Further, the sealing element **100** is inserted into a crack induction cut of the concrete pavements **S1**, **S2**. In order to insert the housing **105**, at first, the housing **105** is compressed such that the width of the housing **105** becomes less than the width of the gap **205** provided between the first pavement **S1** and the second pavement **S2**. For example, the housing **105** may be compressed to have width of 1-2mm and brought inside the
30 gap **205** as shown in **FIG. 2B**. Subsequently, the housing **105** may be released such that the housing **105** expands thereby increasing the width of the housing **105**. In order words, the

housing **105** expands outwardly and moves closer to the walls (**202, 204**) of the first pavement **S1** and the second pavement **S2**. The housing **105** expands outward and the sealing element **100** is held against the walls (**202, 204**) of the first pavement **S1** and the second pavement **S2**.

5 [034] As explained above, the housing **105** comprises the plurality of fins **110** provided at outer surface (length) of the housing **105**. The plurality of fins **110** are used to provide additional grip to hold the sealing element **100** against the walls (**202, 204**) of the first pavement **S1** and the second pavement **S2**. It should be understood that the when the housing **105** expands outward, the plurality of fins **110** are also held against the walls (**202, 204**) of the first pavement **S1** and
10 the second pavement **S2** and provides additional grip.

[035] In one implementation, the sealing element **100** comprises an adhesive (not shown) provided at surface of the sealing element **100** i.e., across the length of the housing **105** to hold the sealing element **100** against the walls (**202, 204**) of the first pavement **S1** and the second
15 pavement **S2** and to provide additional grip.

[036] Referring to **FIG. 2C**, a perspective view of the sealing element **100** placed in the gap **205** provided between the concrete pavements **S1, S2** is shown. The gap **205** is provided along the length of the concrete pavements **S1, S2**, as shown. The concrete pavement **200** is separated
20 by a predefined length of cut, for example, the length of the cut is 15mm. It should be understood that the length of the cut may be selected in the range of 15mm to 25mm or more.

[037] Referring now to **FIG. 2D, 2E and 2F**, the first pavement **S1** and the second pavement **S2** comprising a cut section **210** is shown, in accordance with one embodiment of the present
25 disclosure. The cut section **210** may be provided in bevel shape, slant, slope or any other shape. The cut section **210** may be a length of 3mm or less. The cut section **210** is provided to insert the sealant element **100** easily in the gap **205** provided between the first pavement **S1** and the second pavement **S2**. Further, the cut section **210** is provided to reduce stress when the vehicle comes in contact with the first pavement **S1** and the second pavement **S2**.

30

[038] It should be understood that the above disclosure that the sealant element can be used to seal the gap between the concrete pavements of 5mm or less. The seal element can be made using a fabrication / extrusion process. The sealant element can be inserted in the gap as a continuous strip with ease. Further, the seal element can withstand high stress due to its expansion property as being in the solid structure.

[039] While specific language has been used to describe the disclosure, any limitations arising on account of the same are not intended. As would be apparent to a person skilled in the art, various working modifications may be made to the method in order to implement the inventive concept as taught herein.

[040] The figures and the foregoing description give examples of embodiments. Those skilled in the art will appreciate that one or more of the described elements may well be combined into a single functional element. Alternatively, certain elements may be split into multiple functional elements. Elements from one embodiment may be added to another embodiment. For example, orders of processes described herein may be changed and are not limited to the manner described herein. Moreover, the actions of any flow diagram need not be implemented in the order shown; nor do all of the acts necessarily need to be performed. Also, those acts that are not dependent on other acts may be performed in parallel with the other acts. The scope of embodiments is by no means limited by these specific examples. Numerous variations, whether explicitly given in the specification or not, such as differences in structure, dimension, and use of material, are possible.

REFERENCE NUMERALS

- Sealing Element **100**
- Housing **105**
- 5 Top End **106**
- Bottom End **107**
- First Side **108**
- Second Side **109**
- Fins **110**
- 10 Concrete Pavement **200**
- First Wall **202**
- Second Wall **204**
- Gap **205**
- Cut Section **210**
- 15 First Pavement **S1**
- Second Pavement **S2**

CLAIM:

1. A sealing element (100) for sealing a gap (205) between concrete pavements (S1, S2), comprising:
- 5 a housing (105) provided in a solid structure; and
a plurality of fins (110) coupled to the housing (105) at outer surface,
wherein the housing (105) is compressed and placed between concrete pavements (S1, S2) having a gap (205) may be in between a range of 1mm to 5mm, wherein the housing (105) expands outward and the housing (105) is held against walls (202, 204) of the concrete pavements (S1, S2), and wherein the plurality of fins grips are held against walls (202, 204) of
10 the concrete pavements (S1, S2).
2. The sealing element (100) as claimed in claim 1, wherein the housing (105) is a continuous strip or jointed strip
- 15
3. The sealing element (100) as claimed in claim 1, wherein the housing (105) is made using one of:
- rubber,
plastic,
20 ethylene vinyl acetate, and
combination thereof.
4. The sealing element (100) as claimed in claim 1, wherein the plurality of fins (110) are coupled to the housing (105) symmetrically or asymmetrically.
- 25
5. The sealing element (100) as claimed in claim 1, wherein the plurality of fins (110) are coupled at perpendicular or at an acute angle at length of the housing (105).
6. The sealing element (100) as claimed in claim 5, wherein the plurality of fins (110) are
30 spaced at equal distance or at variable distance.

7. The sealing element (100) as claimed in claim 1, wherein width of the sealing element (100) is reduced to 1:10 when the housing (105) is compressed.
- 5 8. The sealing element (100) as claimed in claim 1, wherein width of the housing (105) is less, equal or more than the length of the sealing element (100) prior to compression.
9. The sealing element (100) as claimed in claim 1, wherein the sealing element (100) comprises an adhesive provided at substrate of the housing (105) to hold and to strengthen the
10 sealing element (100) against the walls (202, 204) of the concrete pavements (S1, S2).
10. The sealing element (100) as claimed in claim 1, wherein the sealing element (100) is inserted by an applicator machine and the sealing element (100) is inserted into a crack induction cut of the concrete pavements (S1, S2).

15

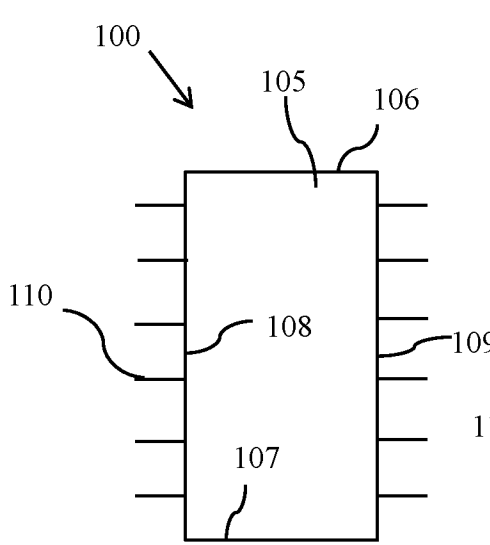

FIG. 1A

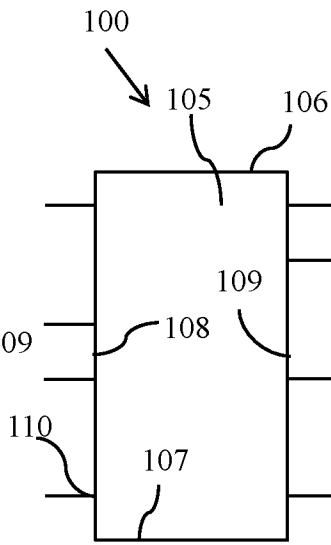

FIG. 1B

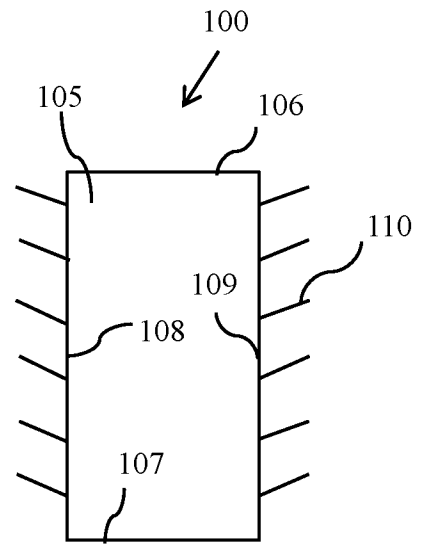

FIG. 1C

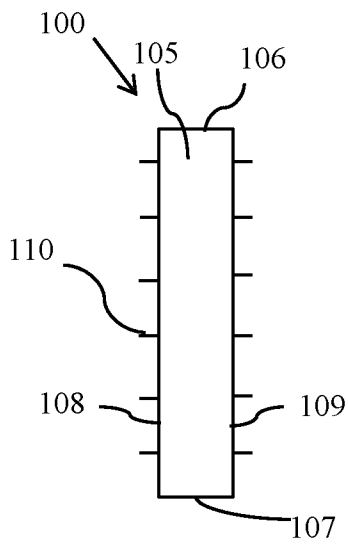

FIG. 1D

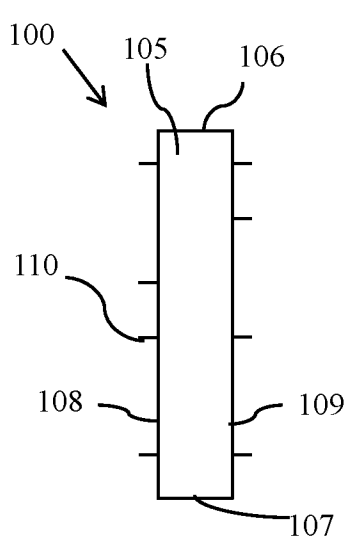

FIG. 1E

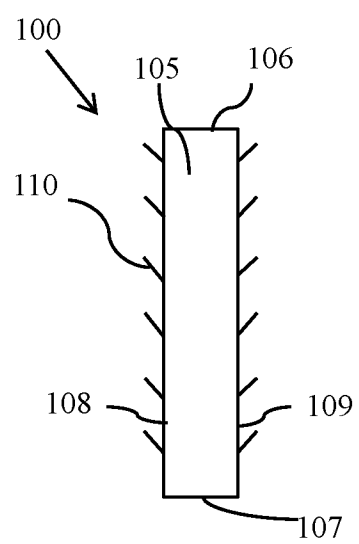

FIG. 1F

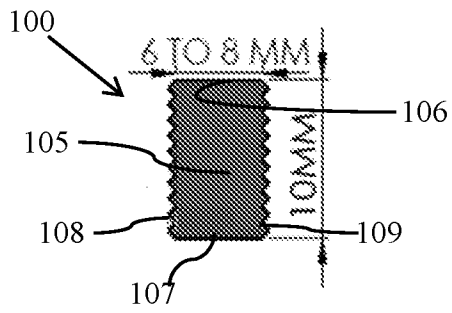

FIG. 1G

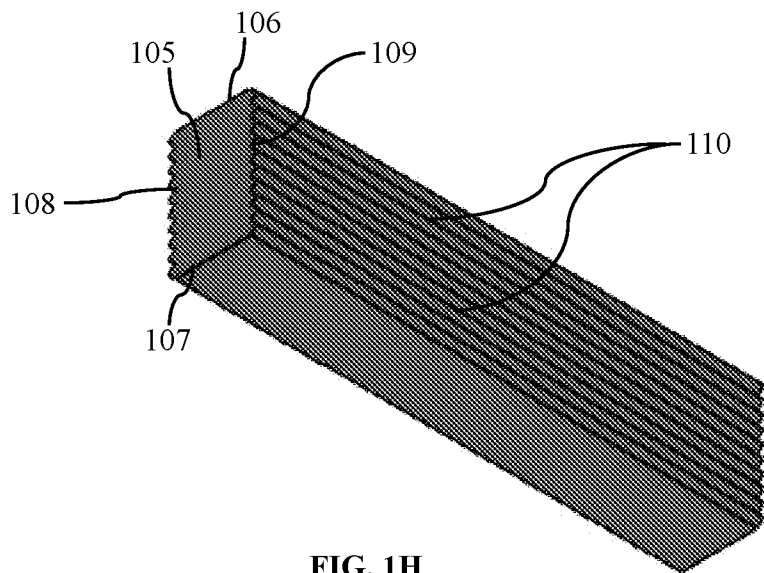

FIG. 1H

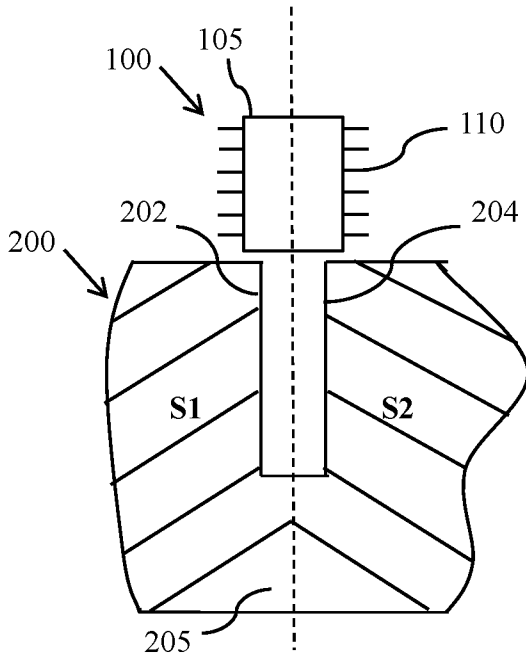

FIG. 2A

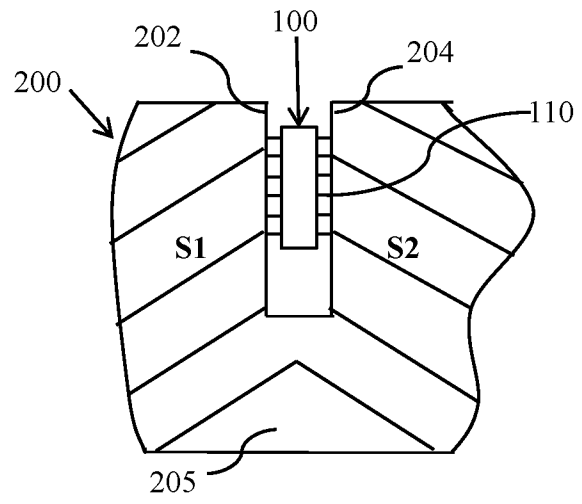

FIG. 2B

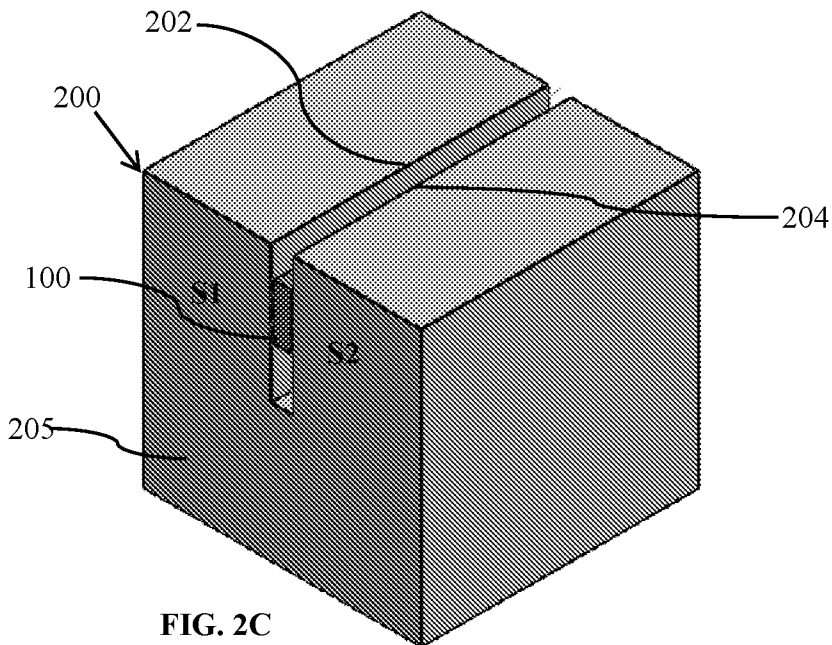

FIG. 2C

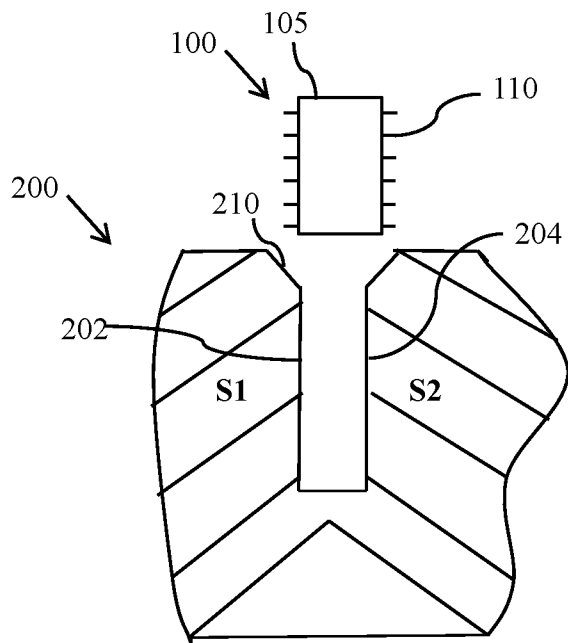

FIG. 2D

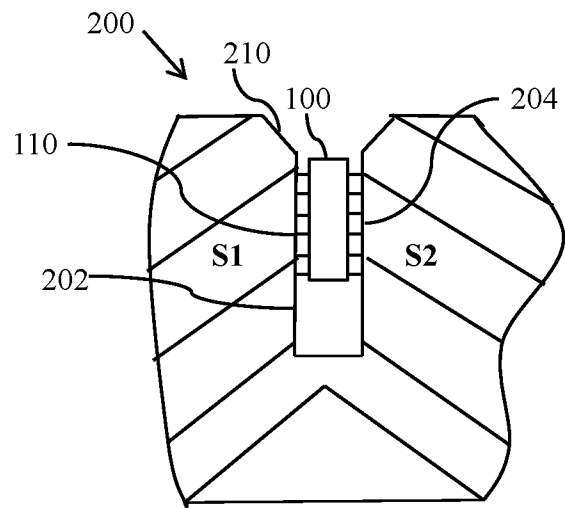

FIG. 2E

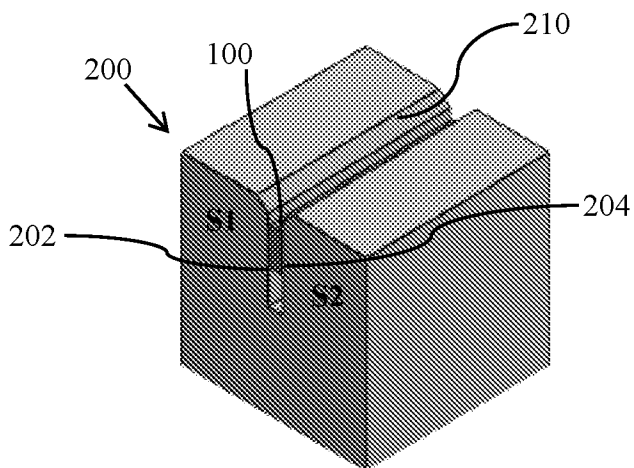

FIG. 2F

INTERNATIONAL SEARCH REPORT

International application No.
PCT/IN2019/050473

A. CLASSIFICATION OF SUBJECT MATTER E04B1/66, E04G23/02, E01C11/02 Version=2019.01		
According to International Patent Classification (IPC) or to both national classification and IPC		
B. FIELDS SEARCHED		
Minimum documentation searched (classification system followed by classification symbols) E04B, E01C		
Documentation searched other than minimum documentation to the extent that such documents are included in the fields searched		
Electronic data base consulted during the international search (name of data base and, where practicable, search terms used) TotalPatent One, IPO Internal Database		
C. DOCUMENTS CONSIDERED TO BE RELEVANT		
Category*	Citation of document, with indication, where appropriate, of the relevant passages	Relevant to claim No.
X	US20150240503A1 (GCP APPLIED TECHNOLOGIES INC) 27 August 2015 (27.08.2015) Figure 7 &10, abstract, Claim 1	1-10
<input type="checkbox"/> Further documents are listed in the continuation of Box C. <input checked="" type="checkbox"/> See patent family annex.		
<p>* Special categories of cited documents:</p> <p>"A" document defining the general state of the art which is not considered to be of particular relevance</p> <p>"D" document cited by the applicant in the international application</p> <p>"E" earlier application or patent but published on or after the international filing date</p> <p>"L" document which may throw doubts on priority claim(s) or which is cited to establish the publication date of another citation or other special reason (as specified)</p> <p>"O" document referring to an oral disclosure, use, exhibition or other means</p> <p>"P" document published prior to the international filing date but later than the priority date claimed</p> <p>"T" later document published after the international filing date or priority date and not in conflict with the application but cited to understand the principle or theory underlying the invention</p> <p>"X" document of particular relevance; the claimed invention cannot be considered novel or cannot be considered to involve an inventive step when the document is taken alone</p> <p>"Y" document of particular relevance; the claimed invention cannot be considered to involve an inventive step when the document is combined with one or more other such documents, such combination being obvious to a person skilled in the art</p> <p>"&" document member of the same patent family</p>		
Date of the actual completion of the international search 16-09-2019		Date of mailing of the international search report 16-09-2019
Name and mailing address of the ISA/ Indian Patent Office Plot No.32, Sector 14, Dwarka, New Delhi-110075 Facsimile No.		Authorized officer Lokesh Sisodiya Telephone No. +91-1125300200

INTERNATIONAL SEARCH REPORT
Information on patent family members

International application No.
PCT/IN2019/050473

Citation	Pub.Date	Family	Pub.Date
US 20150240503 A1	27-08-2015	US 9359761 B2	07-06-2016