



(12) **EUROPEAN PATENT APPLICATION**

- (43) Date of publication: **22.05.2024 Bulletin 2024/21**
- (51) International Patent Classification (IPC): **H04N 19/70 (2014.01)**
- (21) Application number: **24168784.7**
- (52) Cooperative Patent Classification (CPC): **H04N 19/176; H04N 19/122; H04N 19/132; H04N 19/157; H04N 19/167; H04N 19/18; H04N 19/70**
- (22) Date of filing: **21.09.2020**

- (84) Designated Contracting States:
AL AT BE BG CH CY CZ DE DK EE ES FI FR GB GR HR HU IE IS IT LI LT LU LV MC MK MT NL NO PL PT RO RS SE SI SK SM TR
- (30) Priority: **21.09.2019 US 201962903821 P**
23.09.2019 US 201962904627 P
- (62) Document number(s) of the earlier application(s) in accordance with Art. 76 EPC:
20864403.9 / 4 017 007
- (71) Applicant: **LG Electronics Inc.**
Yeongdeungpo-gu
Seoul 07336 (KR)

- (72) Inventors:
- **KOO, Moonmo**
06772 SEOUL (KR)
 - **LIM, Jaehyun**
06772 SEOUL (KR)
 - **KIM, Seunghwan**
06772 SEOUL (KR)
- (74) Representative: **Plasseraud IP**
66, rue de la Chaussée d'Antin
75440 Paris Cedex 09 (FR)

Remarks:
This application was filed on 05-04-2024 as a divisional application to the application mentioned under INID code 62.

(54) **IMAGE CODING METHOD BASED ON TRANSFORM, AND DEVICE THEREFOR**

(57) An image decoding method according to the present document may comprise a step of deriving a modified transform coefficient, wherein the step of deriving the modified transform coefficient comprises the steps of: deriving a first variable indicating whether the transform coefficient exists in an area excluding a DC location of the current block; parsing an LFNST index on

the basis of the derivation result; and deriving the modified transform coefficient on the basis of the LFNST index and an LFNST matrix, and on the basis of the fact that the current block is divided into a plurality of sub-partition blocks, the LFNST index can be parsed without deriving the first variable.

FIG. 2

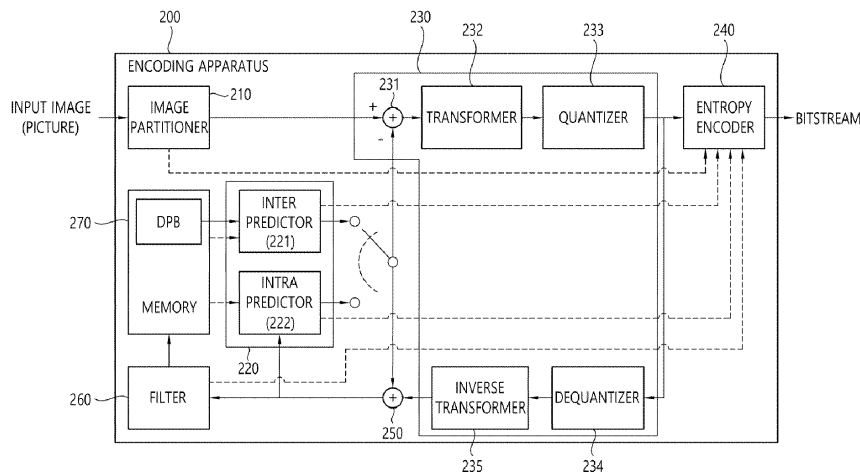

Description**BACKGROUND OF THE DISCLOSURE**5 Field of the disclosure

[0001] The present disclosure relates to an image coding technique and, more particularly, to an apparatus for coding an image based on transform in an image coding system.

10 Related Art

[0002] Nowadays, the demand for high-resolution and high-quality images/videos such as 4K, 8K or more ultra high definition (UHD) images/videos has been increasing in various fields. As the image/video data becomes higher resolution and higher quality, the transmitted information amount or bit amount increases as compared to the conventional image data. Therefore, when image data is transmitted using a medium such as a conventional wired/wireless broadband line or image/video data is stored using an existing storage medium, the transmission cost and the storage cost thereof are increased.

[0003] Further, nowadays, the interest and demand for immersive media such as virtual reality (VR), artificial reality (AR) content or hologram, or the like is increasing, and broadcasting for images/videos having image features different from those of real images, such as a game image is increasing.

[0004] Accordingly, there is a need for a highly efficient image/video compression technique for effectively compressing and transmitting or storing, and reproducing information of high resolution and high quality images/videos having various features as described above. Documents entitled "Versatile Video Coding (Draft 6)", by BROSS B ETAL (no. JVET-O2001, XP030293941), "Algorithm description for Versatile Video Coding and Test Model 6 (VTM 6)", by JIANLE CHEN ETAL (no. JVET-O2002-v2, XP030293946) and "Non-CE6: Simplified LFNST signalling" by JUNG (WILUSGROUP) J ETAL, (no. JVET-O0472, XP030219672) were submitted to this end at the 15. JVET MEETING (THE JOINT VIDEO EXPLORATION TEAM OF ISO/IEC JTC1/SC29/WG11 AND ITU-T SG.16).

30 **SUMMARY**

[0005] A technical aspect of the present disclosure is to provide an apparatus for increasing image coding efficiency.

[0006] Another technical aspect of the present disclosure is to provide an apparatus for increasing efficiency in transform index coding.

[0007] Still another technical aspect of the present disclosure is to provide an image coding apparatus using LFNST.

35 **[0008]** Still another technical aspect of the present disclosure is to provide an image coding apparatus for applying LFNST to a sub-partition block.

[0009] In one aspect of the present disclosure, there is provided an image decoding method performed by a decoding apparatus. The method includes deriving modified transform coefficients, and the deriving of the modified transform coefficients includes deriving a first variable indicating whether the transform coefficients exist in a region except for a DC position of the current block, parsing an LFNST index based on a result of the deriving, and deriving the modified transform coefficients based on the LFNST index and an LFNST matrix. Based on the current block being divided into a plurality of sub-partition blocks, the LFNST index is parsed without deriving the first variable.

[0010] When the current block is not divided into the plurality of sub-partition blocks and the first variable indicates that the transform coefficients exist in a region except for the DC position, the LFNST index may be parsed.

45 **[0011]** The deriving of the modified transform coefficients may further include determining whether the transform coefficients exist in a second region except for the first region at a top-left of the current block, and when the transform coefficients do not exist in the second region, the LFNST index may be parsed.

[0012] When the transform coefficients do not exist in all of the second region of each of the plurality of sub-partition blocks, the LFNST index may be parsed.

50 **[0013]** The current block may be a coding block, and when a width and a height of each sub-partition block are each greater than or equal to 4, the LFNST index for the current block may be applied to the plurality of sub-partition blocks.

[0014] When each of the divided sub-partition blocks is a 4x4 block or a 8x8 block, the LFNST may be applied to up to 8th transform coefficients in a scan direction from a top-left position of the sub-partition block.

55 **[0015]** In another aspect of the present disclosure, there is provided an image encoding method performed by an encoding apparatus. The method includes deriving transform coefficients for a current block based on a primary transform for residual samples of the current block, deriving modified transform coefficients from the transform coefficients based on an LFNST matrix for LFNST, configuring image information so that an LFNST index indicating the LFNST matrix is signaled based on the transform coefficients existing in a region except for a DC position of the current block, and

encoding quantized residual information and the LFNST index. Based on the current block being divided into a plurality of sub-partition blocks, the image information is configured so that the LFNST index is signaled regardless of whether the transform coefficients exist in a region except for the DC position of the current block.

5 [0016] According to still another embodiment of the present disclosure, there may be provided a digital storage medium that stores image data including encoded image information and a bitstream generated according to an image encoding method performed by an encoding apparatus.

[0017] According to yet another embodiment of the present disclosure, there may be provided a digital storage medium that stores image data including encoded image information and a bitstream to cause a decoding apparatus to perform the image decoding method.

10 [0018] According to the present disclosure, it is possible to increase overall image/video compression efficiency.

[0019] According to the present disclosure, it is possible to increase efficiency in transform index coding.

[0020] A technical aspect of the present disclosure may provide an image coding method and apparatus using LFNST.

[0021] Another technical aspect of the present disclosure may provide an image coding method and apparatus for applying LFNST to a sub-partition block.

15 [0022] Effects that can be obtained through specific examples of the present specification are not limited to the effects listed above. For example, various technical effects that a person having ordinary skill in the related art can understand or derive from the present specification may exist. Accordingly, specific effects of the present specification are not limited to those explicitly described in the present specification, and can include various effects that can be understood or derived from the technical characteristics of the present specification.

20 BRIEFDESCRIPTION OF THE DRAWINGS

[0023]

25 FIG. 1 schematically illustrates an example of a video/image coding system to which the present disclosure is applicable.

FIG. 2 is a diagram schematically illustrating a configuration of a video/image encoding apparatus to which the present disclosure is applicable.

30 FIG. 3 is a diagram schematically illustrating a configuration of a video/image decoding apparatus to which the present disclosure is applicable.

FIG. 4 is schematically illustrates a multiple transform scheme according to an embodiment of the present document.

FIG. 5 exemplarily shows intra directional modes of 65 prediction directions.

FIG. 6 is a diagram for explaining RST according to an embodiment of the present.

35 FIG. 7 is a diagram illustrating a sequence of arranging output data of a forward primary transformation into a one-dimensional vector according to an example.

FIG. 8 is a diagram illustrating a sequence of arranging output data of a forward quadratic transform into a two-dimensional block according to an example.

FIG. 9 is a diagram illustrating wide-angle intra prediction modes according to an embodiment of the present document.

40 FIG. 10 is a diagram illustrating a block shape to which LFNST is applied.

FIG. 11 is a diagram illustrating a disposition of output data of a forward LFNST according to an embodiment.

FIG. 12 is a diagram illustrating that the number of output data for a forward LFNST is limited to a maximum of 16 according to an example.

FIG. 13 is a diagram illustrating zero-out in a block to which 4x4 LFNST is applied according to an example.

45 FIG. 14 is a diagram illustrating zero-out in a block to which 8x8 LFNST is applied according to an example.

FIG. 15 is a diagram illustrating zero-out in a block to which 8x8 LFNST is applied according to another example.

FIG. 16 is a diagram illustrating an example of a sub-block into which one coding block is divided.

FIG. 17 is a diagram illustrating another example of a sub-block into which one coding block is divided.

50 FIG. 18 is a diagram illustrating symmetry between an Mx2 (Mx1) block and a 2xM (1xM) block according to an embodiment.

FIG. 19 is a diagram illustrating an example of transposing a 2xM block according to an embodiment.

FIG. 20 illustrates a scanning order for 8x2 or 2x8 regions according to an embodiment.

FIG. 21 is a flowchart illustrating a method of decoding an image according to an embodiment.

FIG. 22 is a flowchart illustrating a method of encoding an image according to an embodiment.

55 FIG. 23 is a diagram illustrating a structure of a content streaming system to which this document is applied.

DESCRIPTION OF EXEMPLARY EMBODIMENTS

[0024] While the present disclosure may be susceptible to various modifications and include various embodiments, specific embodiments thereof have been shown in the drawings by way of example and will now be described in detail. However, this is not intended to limit the present disclosure to the specific embodiments disclosed herein. The terminology used herein is for the purpose of describing specific embodiments only, and is not intended to limit technical idea of the present disclosure. The singular forms may include the plural forms unless the context clearly indicates otherwise. The terms such as "include" and "have" are intended to indicate that features, numbers, steps, operations, elements, components, or combinations thereof used in the following description exist, and thus should not be understood as that the possibility of existence or addition of one or more different features, numbers, steps, operations, elements, components, or combinations thereof is excluded in advance.

[0025] Meanwhile, each component on the drawings described herein is illustrated independently for convenience of description as to characteristic functions different from each other, and however, it is not meant that each component is realized by a separate hardware or software. For example, any two or more of these components may be combined to form a single component, and any single component may be divided into plural components. The embodiments in which components are combined and/or divided will belong to the scope of the patent right of the present disclosure as long as they do not depart from the essence of the present disclosure.

[0026] Hereinafter, preferred embodiments of the present disclosure will be explained in more detail while referring to the attached drawings. In addition, the same reference signs are used for the same components on the drawings, and repeated descriptions for the same components will be omitted.

[0027] This document relates to video/image coding. For example, the method/example disclosed in this document may relate to a VVC (Versatile Video Coding) standard (ITU-T Rec. H.266), a next-generation video/image coding standard after VVC, or other video coding related standards (e.g., HEVC (High Efficiency Video Coding) standard (ITU-T Rec. H.265), EVC (essential video coding) standard, AVS2 standard, etc.).

[0028] In this document, a variety of embodiments relating to video/image coding may be provided, and, unless specified to the contrary, the embodiments may be combined to each other and be performed.

[0029] In this document, a video may mean a set of a series of images over time. Generally a picture means a unit representing an image at a specific time zone, and a slice/tile is a unit constituting a part of the picture. The slice/tile may include one or more coding tree units (CTUs). One picture may be constituted by one or more slices/tiles. One picture may be constituted by one or more tile groups. One tile group may include one or more tiles.

[0030] A pixel or a pel may mean a smallest unit constituting one picture (or image). Also, 'sample' may be used as a term corresponding to a pixel. A sample may generally represent a pixel or a value of a pixel, and may represent only a pixel/pixel value of a luma component or only a pixel/pixel value of a chroma component. Alternatively, the sample may refer to a pixel value in the spatial domain, or when this pixel value is converted to the frequency domain, it may refer to a transform coefficient in the frequency domain.

[0031] A unit may represent the basic unit of image processing. The unit may include at least one of a specific region and information related to the region. One unit may include one luma block and two chroma (e.g., cb, cr) blocks. The unit and a term such as a block, an area, or the like may be used in place of each other according to circumstances. In a general case, an $M \times N$ block may include a set (or an array) of samples (or sample arrays) or transform coefficients consisting of M columns and N rows.

[0032] In this document, the term "/" and "," should be interpreted to indicate "and/or." For instance, the expression "A/B" may mean "A and/or B." Further, "A, B" may mean "A and/or B." Further, "A/B/C" may mean "at least one of A, B, and/or C." Also, "A/B/C" may mean "at least one of A, B, and/or C."

[0033] Further, in the document, the term "or" should be interpreted to indicate "and/or." For instance, the expression "A or B" may include 1) only A, 2) only B, and/or 3) both A and B. In other words, the term "or" in this document should be interpreted to indicate "additionally or alternatively."

[0034] In the present disclosure, "at least one of A and B" may mean "only A", "only B", or "both A and B". In addition, in the present disclosure, the expression "at least one of A or B" or "at least one of A and/or B" may be interpreted as "at least one of A and B".

[0035] In addition, in the present disclosure, "at least one of A, B, and C" may mean "only A", "only B", "only C", or "any combination of A, B, and C". In addition, "at least one of A, B, or C" or "at least one of A, B, and/or C" may mean "at least one of A, B, and C".

[0036] In addition, a parenthesis used in the present disclosure may mean "for example". Specifically, when indicated as "prediction (intra prediction)", it may mean that "intra prediction" is proposed as an example of "prediction". In other words, the "prediction" of the present disclosure is not limited to "intra prediction", and "intra prediction" may be proposed as an example of "prediction". In addition, when indicated as "prediction (i.e., intra prediction)", it may also mean that "intra prediction" is proposed as an example of "prediction".

[0037] Technical features individually described in one figure in the present disclosure may be individually implemented

or may be simultaneously implemented.

[0038] FIG. 1 schematically illustrates an example of a video/image coding system to which the present disclosure is applicable.

[0039] Referring to FIG. 1, the video/image coding system may include a first device (source device) and a second device (receive device). The source device may deliver encoded video/image information or data in the form of a file or streaming to the receive device via a digital storage medium or network.

[0040] The source device may include a video source, an encoding apparatus, and a transmitter. The receive device may include a receiver, a decoding apparatus, and a renderer. The encoding apparatus may be called a video/image encoding apparatus, and the decoding apparatus may be called a video/image decoding apparatus. The transmitter may be included in the encoding apparatus. The receiver may be included in the decoding apparatus. The renderer may include a display, and the display may be configured as a separate device or an external component.

[0041] The video source may obtain a video/image through a process of capturing, synthesizing, or generating a video/image. The video source may include a video/image capture device and/or a video/image generating device. The video/image capture device may include, for example, one or more cameras, video/image archives including previously captured video/images, or the like. The video/image generating device may include, for example, a computer, a tablet and a smartphone, and may (electronically) generate a video/image. For example, a virtual video/image may be generated through a computer or the like. In this case, the video/image capturing process may be replaced by a process of generating related data.

[0042] The encoding apparatus may encode an input video/image. The encoding apparatus may perform a series of procedures such as prediction, transform, and quantization for compression and coding efficiency. The encoded data (encoded video/image information) may be output in the form of a bitstream.

[0043] The transmitter may transmit the encoded video/image information or data output in the form of a bitstream to the receiver of the receive device through a digital storage medium or a network in the form of a file or streaming. The digital storage medium may include various storage mediums such as USB, SD, CD, DVD, Blu-ray, HDD, SSD, and the like. The transmitter may include an element for generating a media file through a predetermined file format, and may include an element for transmission through a broadcast/communication network. The receiver may receive/extract the bitstream and transmit the received/extracted bitstream to the decoding apparatus.

[0044] The decoding apparatus may decode a video/image by performing a series of procedures such as dequantization, inverse transform, prediction, and the like corresponding to the operation of the encoding apparatus.

[0045] The renderer may render the decoded video/image. The rendered video/image may be displayed through the display.

[0046] FIG. 2 is a diagram schematically illustrating a configuration of a video/image encoding apparatus to which the present disclosure is applicable. Hereinafter, what is referred to as the video encoding apparatus may include an image encoding apparatus.

[0047] Referring to FIG. 2, the encoding apparatus 200 may include an image partitioner 210, a predictor 220, a residual processor 230, an entropy encoder 240, an adder 250, a filter 260, and a memory 270. The predictor 220 may include an inter predictor 221 and an intra predictor 222. The residual processor 230 may include a transformer 232, a quantizer 233, a dequantizer 234, an inverse transformer 235. The residual processor 230 may further include a subtractor 231. The adder 250 may be called a reconstructor or reconstructed block generator. The image partitioner 210, the predictor 220, the residual processor 230, the entropy encoder 240, the adder 250, and the filter 260, which have been described above, may be constituted by one or more hardware components (e.g., encoder chipsets or processors) according to an embodiment. Further, the memory 270 may include a decoded picture buffer (DPB), and may be constituted by a digital storage medium. The hardware component may further include the memory 270 as an internal/external component.

[0048] The image partitioner 210 may partition an input image (or a picture or a frame) input to the encoding apparatus 200 into one or more processing units. As one example, the processing unit may be called a coding unit (CU). In this case, starting with a coding tree unit (CTU) or the largest coding unit (LCU), the coding unit may be recursively partitioned according to the Quad-tree binary-tree ternary-tree (QTBT) structure. For example, one coding unit may be divided into a plurality of coding units of a deeper depth based on the quad-tree structure, the binary-tree structure, and/or the ternary structure. In this case, for example, the quad-tree structure may be applied first and the binary-tree structure and/or the ternary structure may be applied later. Alternatively, the binary-tree structure may be applied first. The coding procedure according to the present disclosure may be performed based on the final coding unit which is not further partitioned. In this case, the maximum coding unit may be used directly as a final coding unit based on coding efficiency according to the image characteristic. Alternatively, the coding unit may be recursively partitioned into coding units of a further deeper depth as needed, so that the coding unit of an optimal size may be used as a final coding unit. Here, the coding procedure may include procedures such as prediction, transform, and reconstruction, which will be described later. As another example, the processing unit may further include a prediction unit (PU) or a transform unit (TU). In this case, the prediction unit and the transform unit may be split or partitioned from the above-described final coding unit.

The prediction unit may be a unit of sample prediction, and the transform unit may be a unit for deriving a transform coefficient and/or a unit for deriving a residual signal from a transform coefficient.

[0049] The unit and a term such as a block, an area, or the like may be used in place of each other according to circumstances. In a general case, an $M \times N$ block may represent a set of samples or transform coefficients consisting of M columns and N rows. The sample may generally represent a pixel or a value of a pixel, and may represent only a pixel/pixel value of a luma component, or only a pixel/pixel value of a chroma component. The sample may be used as a term corresponding to a pixel or a pel of one picture (or image).

[0050] The subtractor 231 subtracts a prediction signal (predicted block, prediction sample array) output from the predictor 220 from an input image signal (original block, original sample array) to generate a residual signal (residual block, residual sample array), and the generated residual signal is transmitted to the transformer 232. The predictor 220 may perform prediction on a processing target block (hereinafter, referred to as 'current block'), and may generate a predicted block including prediction samples for the current block. The predictor 220 may determine whether intra prediction or inter prediction is applied on a current block or CU basis. As discussed later in the description of each prediction mode, the predictor may generate various information relating to prediction, such as prediction mode information, and transmit the generated information to the entropy encoder 240. The information on the prediction may be encoded in the entropy encoder 240 and output in the form of a bitstream.

[0051] The intra predictor 222 may predict the current block by referring to samples in the current picture. The referred samples may be located in the neighbor of or apart from the current block according to the prediction mode. In the intra prediction, prediction modes may include a plurality of non-directional modes and a plurality of directional modes. The non-directional modes may include, for example, a DC mode and a planar mode. The directional mode may include, for example, 33 directional prediction modes or 65 directional prediction modes according to the degree of detail of the prediction direction. However, this is merely an example, and more or less directional prediction modes may be used depending on a setting. The intra predictor 222 may determine the prediction mode applied to the current block by using the prediction mode applied to the neighboring block.

[0052] The inter predictor 221 may derive a predicted block for the current block based on a reference block (reference sample array) specified by a motion vector on a reference picture. At this time, in order to reduce the amount of motion information transmitted in the inter prediction mode, the motion information may be predicted on a block, subblock, or sample basis based on correlation of motion information between the neighboring block and the current block. The motion information may include a motion vector and a reference picture index. The motion information may further include inter prediction direction (L0 prediction, L1 prediction, Bi prediction, etc.) information. In the case of inter prediction, the neighboring block may include a spatial neighboring block existing in the current picture and a temporal neighboring block existing in the reference picture. The reference picture including the reference block and the reference picture including the temporal neighboring block may be same to each other or different from each other. The temporal neighboring block may be called a collocated reference block, a collocated CU (colCU), and the like, and the reference picture including the temporal neighboring block may be called a collocated picture (colPic). For example, the inter predictor 221 may configure a motion information candidate list based on neighboring blocks and generate information indicating which candidate is used to derive a motion vector and/or a reference picture index of the current block. Inter prediction may be performed based on various prediction modes. For example, in the case of a skip mode and a merge mode, the inter predictor 221 may use motion information of the neighboring block as motion information of the current block. In the skip mode, unlike the merge mode, the residual signal may not be transmitted. In the case of the motion information prediction (motion vector prediction, MVP) mode, the motion vector of the neighboring block may be used as a motion vector predictor and the motion vector of the current block may be indicated by signaling a motion vector difference.

[0053] The predictor 220 may generate a prediction signal based on various prediction methods. For example, the predictor may apply intra prediction or inter prediction for prediction on one block, and, as well, may apply intra prediction and inter prediction at the same time. This may be called combined inter and intra prediction (CIIP). Further, the predictor may be based on an intra block copy (IBC) prediction mode, or a palette mode in order to perform prediction on a block. The IBC prediction mode or palette mode may be used for content image/video coding of a game or the like, such as screen content coding (SCC). Although the IBC basically performs prediction in a current block, it can be performed similarly to inter prediction in that it derives a reference block in a current block. That is, the IBC may use at least one of inter prediction techniques described in the present disclosure.

[0054] The prediction signal generated through the inter predictor 221 and/or the intra predictor 222 may be used to generate a reconstructed signal or to generate a residual signal. The transformer 232 may generate transform coefficients by applying a transform technique to the residual signal. For example, the transform technique may include at least one of a discrete cosine transform (DCT), a discrete sine transform (DST), a Karhunen-Loève transform (KLT), a graph-based transform (GBT), or a conditionally non-linear transform (CNT). Here, the GBT means transform obtained from a graph when relationship information between pixels is represented by the graph. The CNT refers to transform obtained based on a prediction signal generated using all previously reconstructed pixels. In addition, the transform process may be applied to square pixel blocks having the same size or may be applied to blocks having a variable size rather than

the square one.

[0055] The quantizer 233 may quantize the transform coefficients and transmit them to the entropy encoder 240, and the entropy encoder 240 may encode the quantized signal (information on the quantized transform coefficients) and output the encoded signal in a bitstream. The information on the quantized transform coefficients may be referred to as residual information. The quantizer 233 may rearrange block type quantized transform coefficients into a one-dimensional vector form based on a coefficient scan order, and generate information on the quantized transform coefficients based on the quantized transform coefficients of the one-dimensional vector form. The entropy encoder 240 may perform various encoding methods such as, for example, exponential Golomb, context-adaptive variable length coding (CAVLC), context-adaptive binary arithmetic coding (CABAC), and the like. The entropy encoder 240 may encode information necessary for video/image reconstruction other than quantized transform coefficients (e.g. values of syntax elements, etc.) together or separately. Encoded information (e.g., encoded video/image information) may be transmitted or stored on a unit basis of a network abstraction layer (NAL) in the form of a bitstream. The video/image information may further include information on various parameter sets such as an adaptation parameter set (APS), a picture parameter set (PPS), a sequence parameter set (SPS), a video parameter set (VPS) or the like. Further, the video/image information may further include general constraint information. In the present disclosure, information and/or syntax elements which are transmitted/signaled to the decoding apparatus from the encoding apparatus may be included in video/image information. The video/image information may be encoded through the above-described encoding procedure and included in the bitstream. The bitstream may be transmitted through a network, or stored in a digital storage medium. Here, the network may include a broadcast network, a communication network and/or the like, and the digital storage medium may include various storage media such as USB, SD, CD, DVD, Blu-ray, HDD, SSD, and the like. A transmitter (not shown) which transmits a signal output from the entropy encoder 240 and/or a storage (not shown) which stores it may be configured as an internal/external element of the encoding apparatus 200, or the transmitter may be included in the entropy encoder 240.

[0056] Quantized transform coefficients output from the quantizer 233 may be used to generate a prediction signal. For example, by applying dequantization and inverse transform to quantized transform coefficients through the dequantizer 234 and the inverse transformer 235, the residual signal (residual block or residual samples) may be reconstructed. The adder 155 adds the reconstructed residual signal to a prediction signal output from the inter predictor 221 or the intra predictor 222, so that a reconstructed signal (reconstructed picture, reconstructed block, reconstructed sample array) may be generated. When there is no residual for a processing target block as in a case where the skip mode is applied, the predicted block may be used as a reconstructed block. The adder 250 may be called a reconstructor or a reconstructed block generator. The generated reconstructed signal may be used for intra prediction of a next processing target block in the current block, and as described later, may be used for inter prediction of a next picture through filtering.

[0057] Meanwhile, in the picture encoding and/or reconstructing process, luma mapping with chroma scaling (LMCS) may be applied.

[0058] The filter 260 may improve subjective/objective video quality by applying the filtering to the reconstructed signal. For example, the filter 260 may generate a modified reconstructed picture by applying various filtering methods to the reconstructed picture, and may store the modified reconstructed picture in the memory 270, specifically in the DPB of the memory 270. The various filtering methods may include, for example, deblocking filtering, sample adaptive offset, an adaptive loop filter, a bilateral filter or the like. As discussed later in the description of each filtering method, the filter 260 may generate various information relating to filtering, and transmit the generated information to the entropy encoder 240. The information on the filtering may be encoded in the entropy encoder 240 and output in the form of a bitstream.

[0059] The modified reconstructed picture which has been transmitted to the memory 270 may be used as a reference picture in the inter predictor 221. Through this, the encoding apparatus can avoid prediction mismatch in the encoding apparatus 100 and a decoding apparatus when the inter prediction is applied, and can also improve coding efficiency.

[0060] The memory 270 DPB may store the modified reconstructed picture in order to use it as a reference picture in the inter predictor 221. The memory 270 may store motion information of a block in the current picture, from which motion information has been derived (or encoded) and/or motion information of blocks in an already reconstructed picture. The stored motion information may be transmitted to the inter predictor 221 to be utilized as motion information of a neighboring block or motion information of a temporal neighboring block. The memory 270 may store reconstructed samples of reconstructed blocks in the current picture, and transmit them to the intra predictor 222.

[0061] FIG. 3 is a diagram schematically illustrating a configuration of a video/image decoding apparatus to which the present disclosure is applicable.

[0062] Referring to FIG. 3, the video decoding apparatus 300 may include an entropy decoder 310, a residual processor 320, a predictor 330, an adder 340, a filter 350 and a memory 360. The predictor 330 may include an inter predictor 331 and an intra predictor 332. The residual processor 320 may include a dequantizer 321 and an inverse transformer 321. The entropy decoder 310, the residual processor 320, the predictor 330, the adder 340, and the filter 350, which have been described above, may be constituted by one or more hardware components (e.g., decoder chipsets or processors) according to an embodiment. Further, the memory 360 may include a decoded picture buffer (DPB), and may be con-

stituted by a digital storage medium. The hardware component may further include the memory 360 as an internal/external component.

5 [0063] When a bitstream including video/image information is input, the decoding apparatus 300 may reconstruct an image correspondingly to a process by which video/image information has been processed in the encoding apparatus of FIG. 2. For example, the decoding apparatus 300 may derive units/blocks based on information relating to block partition obtained from the bitstream. The decoding apparatus 300 may perform decoding by using a processing unit applied in the encoding apparatus. Therefore, the processing unit of decoding may be, for example, a coding unit, which may be partitioned along the quad-tree structure, the binary-tree structure, and/or the ternary-tree structure from a coding tree unit or a largest coding unit. One or more transform units may be derived from the coding unit. And, the reconstructed image signal decoded and output through the decoding apparatus 300 may be reproduced through a reproducer.

10 [0064] The decoding apparatus 300 may receive a signal output from the encoding apparatus of FIG. 2 in the form of a bitstream, and the received signal may be decoded through the entropy decoder 310. For example, the entropy decoder 310 may parse the bitstream to derive information (e.g., video/image information) required for image reconstruction (or picture reconstruction). The video/image information may further include information on various parameter sets such as an adaptation parameter set (APS), a picture parameter set (PPS), a sequence parameter set (SPS), a video parameter set (VPS) or the like. Further, the video/image information may further include general constraint information. The decoding apparatus may decode a picture further based on information on the parameter set and/or the general constraint information. In the present disclosure, signaled/received information and/or syntax elements, which will be described later, may be decoded through the decoding procedure and be obtained from the bitstream. For example, the entropy decoder 310 may decode information in the bitstream based on a coding method such as exponential Golomb encoding, CAVLC, CABAC, or the like, and may output a value of a syntax element necessary for image reconstruction and quantized values of a transform coefficient regarding a residual. More specifically, a CABAC entropy decoding method may receive a bin corresponding to each syntax element in a bitstream, determine a context model using decoding target syntax element information and decoding information of neighboring and decoding target blocks, or information of symbol/bin decoded in a previous step, predict bin generation probability according to the determined context model and perform arithmetic decoding of the bin to generate a symbol corresponding to each syntax element value. Here, the CABAC entropy decoding method may update the context model using information of a symbol/bin decoded for a context model of the next symbol/bin after determination of the context model. Information on prediction among information decoded in the entropy decoder 310 may be provided to the predictor (inter predictor 332 and intra predictor 331), and residual values, that is, quantized transform coefficients, on which entropy decoding has been performed in the entropy decoder 310, and associated parameter information may be input to the residual processor 320. The residual processor 320 may derive a residual signal (residual block, residual samples, residual sample array). Further, information on filtering among information decoded in the entropy decoder 310 may be provided to the filter 350. Meanwhile, a receiver (not shown) which receives a signal output from the encoding apparatus may further constitute the decoding apparatus 300 as an internal/external element, and the receiver may be a component of the entropy decoder 310. Meanwhile, the decoding apparatus according to the present disclosure may be called a video/image/picture coding apparatus, and the decoding apparatus may be classified into an information decoder (video/image/picture information decoder) and a sample decoder (video/image/picture sample decoder). The information decoder may include the entropy decoder 310, and the sample decoder may include at least one of the dequantizer 321, the inverse transformer 322, the adder 340, the filter 350, the memory 360, the inter predictor 332, and the intra predictor 331.

35 [0065] The dequantizer 321 may output transform coefficients by dequantizing the quantized transform coefficients. The dequantizer 321 may rearrange the quantized transform coefficients in the form of a two-dimensional block. In this case, the rearrangement may perform rearrangement based on an order of coefficient scanning which has been performed in the encoding apparatus. The dequantizer 321 may perform dequantization on the quantized transform coefficients using quantization parameter (e.g., quantization step size information), and obtain transform coefficients.

40 [0066] The dequantizer 322 obtains a residual signal (residual block, residual sample array) by inverse transforming transform coefficients.

45 [0067] The predictor may perform prediction on the current block, and generate a predicted block including prediction samples for the current block. The predictor may determine whether intra prediction or inter prediction is applied to the current block based on the information on prediction output from the entropy decoder 310, and specifically may determine an intra/inter prediction mode.

50 [0068] The predictor may generate a prediction signal based on various prediction methods. For example, the predictor may apply intra prediction or inter prediction for prediction on one block, and, as well, may apply intra prediction and inter prediction at the same time. This may be called combined inter and intra prediction (CIIP). In addition, the predictor may perform intra block copy (IBC) for prediction on a block. The intra block copy may be used for content image/video coding of a game or the like, such as screen content coding (SCC). Although the IBC basically performs prediction in a current block, it can be performed similarly to inter prediction in that it derives a reference block in a current block. That is, the IBC may use at least one of inter prediction techniques described in the present disclosure.

[0069] The intra predictor 331 may predict the current block by referring to the samples in the current picture. The referred samples may be located in the neighbor of or apart from the current block according to the prediction mode. In the intra prediction, prediction modes may include a plurality of non-directional modes and a plurality of directional modes. The intra predictor 331 may determine the prediction mode applied to the current block by using the prediction mode applied to the neighboring block.

[0070] The inter predictor 332 may derive a predicted block for the current block based on a reference block (reference sample array) specified by a motion vector on a reference picture. At this time, in order to reduce the amount of motion information transmitted in the inter prediction mode, the motion information may be predicted on a block, subblock, or sample basis based on correlation of motion information between the neighboring block and the current block. The motion information may include a motion vector and a reference picture index. The motion information may further include inter prediction direction (L0 prediction, L1 prediction, Bi prediction, etc.) information. In the case of inter prediction, the neighboring block may include a spatial neighboring block existing in the current picture and a temporal neighboring block existing in the reference picture. For example, the inter predictor 332 may configure a motion information candidate list based on neighboring blocks, and derive a motion vector and/or a reference picture index of the current block based on received candidate selection information. Inter prediction may be performed based on various prediction modes, and the information on prediction may include information indicating a mode of inter prediction for the current block.

[0071] The adder 340 may generate a reconstructed signal (reconstructed picture, reconstructed block, reconstructed sample array) by adding the obtained residual signal to the prediction signal (predicted block, prediction sample array) output from the predictor 330. When there is no residual for a processing target block as in a case where the skip mode is applied, the predicted block may be used as a reconstructed block.

[0072] The adder 340 may be called a reconstructor or a reconstructed block generator. The generated reconstructed signal may be used for intra prediction of a next processing target block in the current block, and as described later, may be output through filtering or be used for inter prediction of a next picture.

[0073] Meanwhile, in the picture decoding process, luma mapping with chroma scaling (LMCS) may be applied.

[0074] The filter 350 may improve subjective/objective video quality by applying the filtering to the reconstructed signal. For example, the filter 350 may generate a modified reconstructed picture by applying various filtering methods to the reconstructed picture, and may transmit the modified reconstructed picture in the memory 360, specifically in the DPB of the memory 360. The various filtering methods may include, for example, deblocking filtering, sample adaptive offset, an adaptive loop filter, a bilateral filter or the like.

[0075] The (modified) reconstructed picture which has been stored in the DPB of the memory 360 may be used as a reference picture in the inter predictor 332. The memory 360 may store motion information of a block in the current picture, from which motion information has been derived (or decoded) and/or motion information of blocks in an already reconstructed picture. The stored motion information may be transmitted to the inter predictor 260 to be utilized as motion information of a neighboring block or motion information of a temporal neighboring block. The memory 360 may store reconstructed samples of reconstructed blocks in the current picture, and transmit them to the intra predictor 331.

[0076] In this specification, the examples described in the predictor 330, the dequantizer 321, the inverse transformer 322, and the filter 350 of the decoding apparatus 300 may be similarly or correspondingly applied to the predictor 220, the dequantizer 234, the inverse transformer 235, and the filter 260 of the encoding apparatus 200, respectively.

[0077] As described above, prediction is performed in order to increase compression efficiency in performing video coding. Through this, a predicted block including prediction samples for a current block, which is a coding target block, may be generated. Here, the predicted block includes prediction samples in a space domain (or pixel domain). The predicted block may be indentially derived in the encoding apparatus and the decoding apparatus, and the encoding apparatus may increase image coding efficiency by signaling to the decoding apparatus not original sample value of an original block itself but information on residual (residual information) between the original block and the predicted block. The decoding apparatus may derive a residual block including residual samples based on the residual information, generate a reconstructed block including reconstructed samples by adding the residual block to the predicted block, and generate a reconstructed picture including reconstructed blocks.

[0078] The residual information may be generated through transform and quantization procedures. For example, the encoding apparatus may derive a residual block between the original block and the predicted block, derive transform coefficients by performing a transform procedure on residual samples (residual sample array) included in the residual block, and derive quantized transform coefficients by performing a quantization procedure on the transform coefficients, so that it may signal associated residual information to the decoding apparatus (through a bitstream). Here, the residual information may include value information, position information, a transform technique, transform kernel, a quantization parameter or the like of the quantized transform coefficients. The decoding apparatus may perform a quantization/de-quantization procedure and derive the residual samples (or residual sample block), based on residual information. The decoding apparatus may generate a reconstructed block based on a predicted block and the residual block. The encoding apparatus may derive a residual block by dequantizing/inverse transforming quantized transform coefficients for reference for inter prediction of a next picture, and may generate a reconstructed picture based on this.

[0079] FIG. 4 schematically illustrates a multiple transform technique according to an embodiment of the present disclosure.

[0080] Referring to FIG. 4, a transformer may correspond to the transformer in the encoding apparatus of foregoing FIG. 2, and an inverse transformer may correspond to the inverse transformer in the encoding apparatus of foregoing FIG. 2, or to the inverse transformer in the decoding apparatus of FIG. 3.

[0081] The transformer may derive (primary) transform coefficients by performing a primary transform based on residual samples (residual sample array) in a residual block (S410). This primary transform may be referred to as a core transform. Herein, the primary transform may be based on multiple transform selection (MTS), and when a multiple transform is applied as the primary transform, it may be referred to as a multiple core transform.

[0082] The multiple core transform may represent a method of transforming additionally using discrete cosine transform (DCT) type 2 and discrete sine transform (DST) type 7, DCT type 8, and/or DST type 1. That is, the multiple core transform may represent a transform method of transforming a residual signal (or residual block) of a space domain into transform coefficients (or primary transform coefficients) of a frequency domain based on a plurality of transform kernels selected from among the DCT type 2, the DST type 7, the DCT type 8 and the DST type 1. Herein, the primary transform coefficients may be called temporary transform coefficients from the viewpoint of the transformer.

[0083] In other words, when the conventional transform method is applied, transform coefficients might be generated by applying transform from a space domain to a frequency domain for a residual signal (or residual block) based on the DCT type 2. Unlike to this, when the multiple core transform is applied, transform coefficients (or primary transform coefficients) may be generated by applying transform from a space domain to a frequency domain for a residual signal (or residual block) based on the DCT type 2, the DST type 7, the DCT type 8, and/or DST type 1. Herein, the DCT type 2, the DST type 7, the DCT type 8, and the DST type 1 may be called a transform type, transform kernel or transform core. These DCT/DST transform types can be defined based on basis functions.

[0084] When the multiple core transform is performed, a vertical transform kernel and a horizontal transform kernel for a target block may be selected from among the transform kernels, a vertical transform may be performed on the target block based on the vertical transform kernel, and a horizontal transform may be performed on the target block based on the horizontal transform kernel. Here, the horizontal transform may indicate a transform on horizontal components of the target block, and the vertical transform may indicate a transform on vertical components of the target block. The vertical transform kernel/horizontal transform kernel may be adaptively determined based on a prediction mode and/or a transform index for the target block (CU or subblock) including a residual block.

[0085] Further, according to an example, if the primary transform is performed by applying the MTS, a mapping relationship for transform kernels may be set by setting specific basis functions to predetermined values and combining basis functions to be applied in the vertical transform or the horizontal transform. For example, when the horizontal transform kernel is expressed as trTypeHor and the vertical direction transform kernel is expressed as trTypeVer, a trTypeHor or trTypeVer value of 0 may be set to DCT2, a trTypeHor or trTypeVer value of 1 may be set to DST7, and a trTypeHor or trTypeVer value of 2 may be set to DCT8.

[0086] In this case, MTS index information may be encoded and signaled to the decoding apparatus to indicate any one of a plurality of transform kernel sets. For example, an MTS index of 0 may indicate that both trTypeHor and trTypeVer values are 0, an MTS index of 1 may indicate that both trTypeHor and trTypeVer values are 1, an MTS index of 2 may indicate that the trTypeHor value is 2 and the trTypeVer value is 1, an MTS index of 3 may indicate that the trTypeHor value is 1 and the trTypeVer value is 2, and an MTS index of 4 may indicate that both both trTypeHor and trTypeVer values are 2.

[0087] In one example, transform kernel sets according to MTS index information are illustrated in the following table.

[Table 1]

tu_mts_idx[x0][y0]	0	1	2	3	4
trTypeHor	0	1	2	1	2
trTypeVer	0	1	1	2	1

[0088] The transformer may perform a secondary transform based on the (primary) transform coefficients to derive modified (secondary) transform coefficients (S420). The primary transform is a transform from a spatial domain to a frequency domain, and the secondary transform refers to transforming into a more compact expression using a correlation existing between (primary) transform coefficients. The secondary transform may include a non-separable transform. In this case, the secondary transform may be referred to as a non-separable secondary transform (NSST) or a mode-dependent non-separable secondary transform (MDNSST). The NSST may represent a transform that secondarily transforms (primary) transform coefficients derived through the primary transform based on a non-separable transform matrix to generate modified transform coefficients (or secondary transform coefficients) for a residual signal. Here, the

transform may be applied at once without separating (or independently applying a horizontal/vertical transform) a vertical transform and a horizontal transform to the (primary) transform coefficients based on the non-separable transform matrix. In other words, the NSST is not separately applied to the (primary) transform coefficients in a vertical direction and a horizontal direction, and may represent, for example, a transform method of rearranging two-dimensional signals (transform coefficients) into a one-dimensional signal through a specific predetermined direction (e.g., row-first direction or column-first direction) and then generating modified transform coefficients (or secondary transform coefficients) based on the non-separable transform matrix. For example, a row-first order is to dispose in a line in order of a 1st row, a 2nd row, ..., an Nth row for MxN blocks, and a column-first order is to dispose in a line in order of a 1st column, a 2nd column, ..., an Mth column for MxN blocks. The NSST may be applied to a top-left region of a block (hereinafter, referred to as a transform coefficient block) configured with (primary) transform coefficients. For example, when both a width W and height H of the transform coefficient block are 8 or more, an 8x8 NSST may be applied to the top-left 8x8 region of the transform coefficient block. Further, while both the width (W) and height (H) of the transform coefficient block are 4 or more, when the width (W) or height (H) of the transform coefficient block is smaller than 8, 4x4 NSST may be applied to the top-left min(8,W)xmin(8,H) region of the transform coefficient block. However, the embodiment is not limited thereto, and for example, even if only the condition that the width W or the height H of the transform coefficient block is 4 or greater is satisfied, the 4x4 NSST may be applied to the top-left end min(8,W)xmin(8,H) region of the transform coefficient block.

[0089] Specifically, for example, if a 4x4 input block is used, the non-separable secondary transform may be performed as follows.

[0090] The 4x4 input block X may be represented as follows.

[Equation 1]

$$X = \begin{bmatrix} X_{00} & X_{01} & X_{02} & X_{03} \\ X_{10} & X_{11} & X_{12} & X_{13} \\ X_{20} & X_{21} & X_{22} & X_{23} \\ X_{30} & X_{31} & X_{32} & X_{33} \end{bmatrix}$$

[0091] If the X is represented in the form of a vector, the vector \vec{X} may be represented as below.

[Equation 2]

$$\vec{X} = [X_{00} \ X_{01} \ X_{02} \ X_{03} \ X_{10} \ X_{11} \ X_{12} \ X_{13} \ X_{20} \ X_{21} \ X_{22} \ X_{23} \ X_{30} \ X_{31} \ X_{32} \ X_{33}]^T$$

[0092] In Equation 2, the vector X is a one-dimensional vector obtained by rearranging the two-dimensional block X of Equation 1 according to the row-first order.

[0093] In this case, the secondary non-separable transform may be calculated as below.

[Equation 3]

$$\vec{F} = T \cdot \vec{X}$$

[0094] In this equation, \vec{F} represents a transform coefficient vector, and T represents a 16x16 (non-separable) transform matrix.

[0095] Through foregoing Equation 3, a 16x1 transform coefficient vector \vec{F} may be derived, and the \vec{F} may be re-organized into a 4x4 block through a scan order (horizontal, vertical, diagonal and the like). However, the above-described calculation is an example, and hypercube-Givens transform (HyGT) or the like may be used for the calculation of the non-separable secondary transform in order to reduce the computational complexity of the non-separable secondary transform.

[0096] Meanwhile, in the non-separable secondary transform, a transform kernel (or transform core, transform type) may be selected to be mode dependent. In this case, the mode may include the intra prediction mode and/or the inter prediction mode.

[0097] As described above, the non-separable secondary transform may be performed based on an 8x8 transform or a 4x4 transform determined based on the width (W) and the height (H) of the transform coefficient block. The 8x8 transform refers to a transform that is applicable to an 8x8 region included in the transform coefficient block when both W and H are equal to or greater than 8, and the 8x8 region may be a top-left 8x8 region in the transform coefficient block. Similarly, the 4x4 transform refers to a transform that is applicable to a 4x4 region included in the transform coefficient block when both W and H are equal to or greater than 4, and the 4x4 region may be a top-left 4x4 region in the transform coefficient block. For example, an 8x8 transform kernel matrix may be a 64x64/16x64 matrix, and a 4x4 transform kernel matrix may be a 16x16/8x16 matrix.

[0098] Here, to select a mode-dependent transform kernel, two non-separable secondary transform kernels per transform set for a non-separable secondary transform may be configured for both the 8x8 transform and the 4x4 transform, and there may be four transform sets. That is, four transform sets may be configured for the 8x8 transform, and four transform sets may be configured for the 4x4 transform. In this case, each of the four transform sets for the 8x8 transform may include two 8x8 transform kernels, and each of the four transform sets for the 4x4 transform may include two 4x4 transform kernels.

[0099] However, as the size of the transform, that is, the size of a region to which the transform is applied, may be, for example, a size other than 8x8 or 4x4, the number of sets may be n, and the number of transform kernels in each set may be k.

[0100] The transform set may be referred to as an NSST set or an LFNST set. A specific set among the transform sets may be selected, for example, based on the intra prediction mode of the current block (CU or subblock). A low-frequency non-separable transform (LFNST) may be an example of a reduced non-separable transform, which will be described later, and represents a non-separable transform for a low frequency component.

[0101] For reference, for example, the intra prediction mode may include two non-directional (or non-angular) intra prediction modes and 65 directional (or angular) intra prediction modes. The non-directional intra prediction modes may include a planar intra prediction mode of No. 0 and a DC intra prediction mode of No. 1, and the directional intra prediction modes may include 65 intra prediction modes of Nos. 2 to 66. However, this is an example, and this document may be applied even when the number of intra prediction modes is different. Meanwhile, in some cases, intra prediction mode No. 67 may be further used, and the intra prediction mode No. 67 may represent a linear model (LM) mode.

[0102] FIG. 5 exemplarily shows intra directional modes of 65 prediction directions.

[0103] Referring to FIG. 5, on the basis of intra prediction mode 34 having a left upward diagonal prediction direction, the intra prediction modes may be divided into intra prediction modes having horizontal directionality and intra prediction modes having vertical directionality. In FIG. 5, H and V denote horizontal directionality and vertical directionality, respectively, and numerals -32 to 32 indicate displacements in 1/32 units on a sample grid position. These numerals may represent an offset for a mode index value. Intra prediction modes 2 to 33 have the horizontal directionality, and intra prediction modes 34 to 66 have the vertical directionality. Strictly speaking, intra prediction mode 34 may be considered as being neither horizontal nor vertical, but may be classified as belonging to the horizontal directionality in determining a transform set of a secondary transform. This is because input data is transposed to be used for a vertical direction mode symmetrical on the basis of intra prediction mode 34, and an input data alignment method for a horizontal mode is used for intra prediction mode 34. Transposing input data means that rows and columns of two-dimensional MxN block data are switched into NxM data. Intra prediction mode 18 and intra prediction mode 50 may represent a horizontal intra prediction mode and a vertical intra prediction mode, respectively, and intra prediction mode 2 may be referred to as a right upward diagonal intra prediction mode because intra prediction mode 2 has a left reference pixel and performs prediction in a right upward direction. Likewise, intra prediction mode 34 may be referred to as a right downward diagonal intra prediction mode, and intra prediction mode 66 may be referred to as a left downward diagonal intra prediction mode.

[0104] According to an example, the four transform sets according to the intra prediction mode may be mapped, for example, as shown in the following table.

[Table 2]

lfnstPredModelIntra	lfnstTrSetIdx
lfnstPredModelIntra < 0	1
<= lfnstPredModelIntra <= 1	0
2 <= lfnstPredModelIntra <= 12	1
13 <= lfnstPredModelIntra <= 23	2
24 <= lfnstPredModelIntra <= 44	3
45 <= lfnstPredModelIntra <= 55	2

(continued)

IfnstPredModelIntra	IfnstTrSetIdx
56 <= IfnstPredModelIntra <= 80	1
81 <= IfnstPredModelIntra <= 83	0

[0105] As shown in Table 2, any one of the four transform sets, that is, IfnstTrSetIdx, may be mapped to any one of four indexes, that is, 0 to 3, according to the intra prediction mode.

[0106] When it is determined that a specific set is used for the non-separable transform, one of k transform kernels in the specific set may be selected through a non-separable secondary transform index. An encoding apparatus may derive a non-separable secondary transform index indicating a specific transform kernel based on a rate-distortion (RD) check and may signal the non-separable secondary transform index to a decoding apparatus. The decoding apparatus may select one of the k transform kernels in the specific set based on the non-separable secondary transform index. For example, Ifnst index value 0 may refer to a first non-separable secondary transform kernel, Ifnst index value 1 may refer to a second non-separable secondary transform kernel, and Ifnst index value 2 may refer to a third non-separable secondary transform kernel. Alternatively, Ifnst index value 0 may indicate that the first non-separable secondary transform is not applied to the target block, and Ifnst index values 1 to 3 may indicate the three transform kernels.

[0107] The transformer may perform the non-separable secondary transform based on the selected transform kernels, and may obtain modified (secondary) transform coefficients. As described above, the modified transform coefficients may be derived as transform coefficients quantized through the quantizer, and may be encoded and signaled to the decoding apparatus and transferred to the dequantizer/inverse transformer in the encoding apparatus.

[0108] Meanwhile, as described above, if the secondary transform is omitted, (primary) transform coefficients, which are an output of the primary (separable) transform, may be derived as transform coefficients quantized through the quantizer as described above, and may be encoded and signaled to the decoding apparatus and transferred to the dequantizer/inverse transformer in the encoding apparatus.

[0109] The inverse transformer may perform a series of procedures in the inverse order to that in which they have been performed in the above-described transformer. The inverse transformer may receive (dequantized) transformer coefficients, and derive (primary) transform coefficients by performing a secondary (inverse) transform (S450), and may obtain a residual block (residual samples) by performing a primary (inverse) transform on the (primary) transform coefficients (S460). In this connection, the primary transform coefficients may be called modified transform coefficients from the viewpoint of the inverse transformer. As described above, the encoding apparatus and the decoding apparatus may generate the reconstructed block based on the residual block and the predicted block, and may generate the reconstructed picture based on the reconstructed block.

[0110] The decoding apparatus may further include a secondary inverse transform application determinator (or an element to determine whether to apply a secondary inverse transform) and a secondary inverse transform determinator (or an element to determine a secondary inverse transform). The secondary inverse transform application determinator may determine whether to apply a secondary inverse transform. For example, the secondary inverse transform may be an NSST, an RST, or an LFNST and the secondary inverse transform application determinator may determine whether to apply the secondary inverse transform based on a secondary transform flag obtained by parsing the bitstream. In another example, the secondary inverse transform application determinator may determine whether to apply the secondary inverse transform based on a transform coefficient of a residual block.

[0111] The secondary inverse transform determinator may determine a secondary inverse transform. In this case, the secondary inverse transform determinator may determine the secondary inverse transform applied to the current block based on an LFNST (NSST or RST) transform set specified according to an intra prediction mode. In an embodiment, a secondary transform determination method may be determined depending on a primary transform determination method. Various combinations of primary transforms and secondary transforms may be determined according to the intra prediction mode. Further, in an example, the secondary inverse transform determinator may determine a region to which a secondary inverse transform is applied based on the size of the current block.

[0112] Meanwhile, as described above, if the secondary (inverse) transform is omitted, (dequantized) transform coefficients may be received, the primary (separable) inverse transform may be performed, and the residual block (residual samples) may be obtained. As described above, the encoding apparatus and the decoding apparatus may generate the reconstructed block based on the residual block and the predicted block, and may generate the reconstructed picture based on the reconstructed block.

[0113] Meanwhile, in the present disclosure, a reduced secondary transform (RST) in which the size of a transform matrix (kernel) is reduced may be applied in the concept of NSST in order to reduce the amount of computation and memory required for the non-separable secondary transform.

[0114] Meanwhile, the transform kernel, the transform matrix, and the coefficient constituting the transform kernel matrix, that is, the kernel coefficient or the matrix coefficient, described in the present disclosure may be expressed in 8 bits. This may be a condition for implementation in the decoding apparatus and the encoding apparatus, and may reduce the amount of memory required to store the transform kernel with a performance degradation that can be reasonably accommodated compared to the existing 9 bits or 10 bits. In addition, the expressing of the kernel matrix in 8 bits may allow a small multiplier to be used, and may be more suitable for single instruction multiple data (SIMD) instructions used for optimal software implementation.

[0115] In the present specification, the term "RST" may mean a transform which is performed on residual samples for a target block based on a transform matrix whose size is reduced according to a reduced factor. In the case of performing the reduced transform, the amount of computation required for transform may be reduced due to a reduction in the size of the transform matrix. That is, the RST may be used to address the computational complexity issue occurring at the non-separable transform or the transform of a block of a great size.

[0116] RST may be referred to as various terms, such as reduced transform, reduced secondary transform, reduction transform, simplified transform, simple transform, and the like, and the name which RST may be referred to as is not limited to the listed examples. Alternatively, since the RST is mainly performed in a low-frequency region including a non-zero coefficient in a transform block, it may be referred to as a Low-Frequency Non-Separable Transform (LFNST). The transform index may be referred to as an LFNST index.

[0117] Meanwhile, when the secondary inverse transform is performed based on RST, the inverse transformer 235 of the encoding apparatus 200 and the inverse transformer 322 of the decoding apparatus 300 may include an inverse reduced secondary transformer which derives modified transform coefficients based on the inverse RST of the transform coefficients, and an inverse primary transformer which derives residual samples for the target block based on the inverse primary transform of the modified transform coefficients. The inverse primary transform refers to the inverse transform of the primary transform applied to the residual. In the present disclosure, deriving a transform coefficient based on a transform may refer to deriving a transform coefficient by applying the transform.

[0118] FIG. 6 is a diagram illustrating an RST according to an embodiment of the present disclosure.

[0119] In the present disclosure, a "target block" may refer to a current block to be coded, a residual block, or a transform block.

[0120] In the RST according to an example, an N-dimensional vector may be mapped to an R-dimensional vector located in another space, so that the reduced transform matrix may be determined, where R is less than N. N may mean the square of the length of a side of a block to which the transform is applied, or the total number of transform coefficients corresponding to a block to which the transform is applied, and the reduced factor may mean an R/N value. The reduced factor may be referred to as a reduced factor, reduction factor, simplified factor, simple factor or other various terms. Meanwhile, R may be referred to as a reduced coefficient, but according to circumstances, the reduced factor may mean R. Further, according to circumstances, the reduced factor may mean the N/R value.

[0121] In an example, the reduced factor or the reduced coefficient may be signaled through a bitstream, but the example is not limited to this. For example, a predefined value for the reduced factor or the reduced coefficient may be stored in each of the encoding apparatus 200 and the decoding apparatus 300, and in this case, the reduced factor or the reduced coefficient may not be signaled separately.

[0122] The size of the reduced transform matrix according to an example may be RxN less than N × N, the size of a conventional transform matrix, and may be defined as in Equation 4 below.

[Equation 4]

$$T_{RxN} = \begin{bmatrix} t_{11} & t_{12} & t_{13} & \dots & t_{1N} \\ t_{21} & t_{22} & t_{23} & \dots & t_{2N} \\ \vdots & \vdots & \vdots & \ddots & \vdots \\ t_{R1} & t_{R2} & t_{R3} & \dots & t_{RN} \end{bmatrix}$$

[0123] The matrix T in the Reduced Transform block shown in (a) of FIG. 6 may mean the matrix TRxN of Equation 4. As shown in (a) of FIG. 6, when the reduced transform matrix TRxN is multiplied to residual samples for the target block, transform coefficients for the target block may be derived.

[0124] In an example, if the size of the block to which the transform is applied is 8x8 and R=16 (i.e., R/N = 16/64 = 1/4), then the RST according to (a) of FIG. 6 may be expressed as a matrix operation as shown in Equation 5 below. In this case, memory and multiplication calculation can be reduced to approximately 1/4 by the reduced factor.

[0125] In the present disclosure, a matrix operation may be understood as an operation of multiplying a column vector by a matrix, disposed on the left of the column vector, to obtain a column vector.

[Equation 5]

$$\begin{bmatrix} t_{1,1} & t_{1,2} & t_{1,3} & \dots & t_{1,64} \\ t_{2,1} & t_{2,2} & t_{2,3} & & t_{2,64} \\ & \vdots & & \ddots & \vdots \\ t_{16,1} & t_{16,2} & t_{16,3} & \dots & t_{16,64} \end{bmatrix} \times \begin{bmatrix} r_1 \\ r_2 \\ \vdots \\ r_{64} \end{bmatrix}$$

[0126] In Equation 5, r_1 to r_{64} may represent residual samples for the target block and may be specifically transform coefficients generated by applying a primary transform. As a result of the calculation of Equation 5 transform coefficients c_i for the target block may be derived, and a process of deriving c_i may be as in Equation 6.

[Equation 6]

for i from 1 to R:

$c_i = 0$

for j from 1 to N

$c_i += t_{ij} * r_j$

[0127] As a result of the calculation of Equation 6, transform coefficients c_1 to c_R for the target block may be derived. That is, when $R=16$, transform coefficients c_1 to c_{16} for the target block may be derived. If, instead of RST, a regular transform is applied and a transform matrix of 64×64 ($N \times N$) size is multiplied to residual samples of 64×1 ($N \times 1$) size, then only 16 (R) transform coefficients are derived for the target block because RST was applied, although 64 (N) transform coefficients are derived for the target block. Since the total number of transform coefficients for the target block is reduced from N to R , the amount of data transmitted by the encoding apparatus 200 to the decoding apparatus 300 decreases, so efficiency of transmission between the encoding apparatus 200 and the decoding apparatus 300 can be improved.

[0128] When considered from the viewpoint of the size of the transform matrix, the size of the regular transform matrix is 64×64 ($N \times N$), but the size of the reduced transform matrix is reduced to 16×64 ($R \times N$), so memory usage in a case of performing the RST can be reduced by an R/N ratio when compared with a case of performing the regular transform. In addition, when compared to the number of multiplication calculations $N \times N$ in a case of using the regular transform matrix, the use of the reduced transform matrix can reduce the number of multiplication calculations by the R/N ratio ($R \times N$).

[0129] In an example, the transformer 232 of the encoding apparatus 200 may derive transform coefficients for the target block by performing the primary transform and the RST-based secondary transform on residual samples for the target block. These transform coefficients may be transferred to the inverse transformer of the decoding apparatus 300, and the inverse transformer 322 of the decoding apparatus 300 may derive the modified transform coefficients based on the inverse reduced secondary transform (RST) for the transform coefficients, and may derive residual samples for the target block based on the inverse primary transform for the modified transform coefficients.

[0130] The size of the inverse RST matrix $T_{N \times R}$ according to an example is $N \times R$ less than the size $N \times N$ of the regular inverse transform matrix, and is in a transpose relationship with the reduced transform matrix $T_{R \times N}$ shown in Equation 4.

[0131] The matrix T^t in the Reduced Inv. Transform block shown in (b) of FIG. 6 may mean the inverse RST matrix $T_{R \times N}^T$ (the superscript T means transpose). When the inverse RST matrix $T_{R \times N}^T$ is multiplied to the transform coefficients for the target block as shown in (b) of FIG. 6, the modified transform coefficients for the target block or the residual samples for the current block may be derived. The inverse RST matrix $T_{R \times N}^T$ may be expressed as $(T_{R \times N})^T_{N \times R}$.

[0132] More specifically, when the inverse RST is applied as the secondary inverse transform, the modified transform coefficients for the target block may be derived when the inverse RST matrix $T_{R \times N}^T$ is multiplied to the transform coefficients for the target block. Meanwhile, the inverse RST may be applied as the inverse primary transform, and in

this case, the residual samples for the target block may be derived when the inverse RST matrix $T_{R \times N}^T$ is multiplied to the transform coefficients for the target block.

[0133] In an example, if the size of the block to which the inverse transform is applied is 8x8 and R =16 (i.e., R/N = 16/64 = 1/4), then the RST according to (b) of FIG. 6 may be expressed as a matrix operation as shown in Equation 7 below.

[Equation 7]

$$\begin{bmatrix} t_{1,1} & t_{2,1} & & t_{16,1} \\ t_{1,2} & t_{2,2} & \dots & t_{16,2} \\ t_{1,3} & t_{2,3} & & t_{16,3} \\ \vdots & \vdots & & \vdots \\ & \vdots & \ddots & \vdots \\ t_{1,64} & t_{2,64} & \dots & t_{16,64} \end{bmatrix} \times \begin{bmatrix} c_1 \\ c_2 \\ \vdots \\ c_{16} \end{bmatrix}$$

[0134] In Equation 7, c_1 to c_{16} may represent the transform coefficients for the target block. As a result of the calculation of Equation 7, r_i representing the modified transform coefficients for the target block or the residual samples for the target block may be derived, and the process of deriving r_i may be as in Equation 8.

[Equation 8]

```

For i from 1 to N
  ri = 0
  for j from 1 to R
    ri += tji * cj
  
```

[0135] As a result of the calculation of Equation 8, r_1 to r_N representing the modified transform coefficients for the target block or the residual samples for the target block may be derived. When considered from the viewpoint of the size of the inverse transform matrix, the size of the regular inverse transform matrix is 64x64 (NxN), but the size of the reduced inverse transform matrix is reduced to 64x16 (RxN), so memory usage in a case of performing the inverse RST can be reduced by an R/N ratio when compared with a case of performing the regular inverse transform. In addition, when compared to the number of multiplication calculations $N \times N$ in a case of using the regular inverse transform matrix, the use of the reduced inverse transform matrix can reduce the number of multiplication calculations by the R/N ratio (NxR).

[0136] A transform set configuration shown in Table 2 may also be applied to an 8×8 RST. That is, the 8×8 RST may be applied according to a transform set in Table 2. Since one transform set includes two or three transforms (kernels) according to an intra prediction mode, it may be configured to select one of up to four transforms including that in a case where no secondary transform is applied. In a transform where no secondary transform is applied, it may be considered to apply an identity matrix. Assuming that indexes 0, 1, 2, and 3 are respectively assigned to the four transforms (e.g., index 0 may be allocated to a case where an identity matrix is applied, that is, a case where no secondary transform is applied), a transform index or an lfnst index as a syntax element may be signaled for each transform coefficient block, thereby designating a transform to be applied. That is, for a top-left 8×8 block, through the transform index, it is possible to designate an 8×8 RST in an RST configuration, or to designate an 8×8 lfnst when the LFNST is applied. The 8×8 lfnst and the 8×8 RST refer to transforms applicable to an 8×8 region included in the transform coefficient block when both W and H of the target block to be transformed are equal to or greater than 8, and the 8×8 region may be a top-left 8×8 region in the transform coefficient block. Similarly, a 4×4 lfnst and a 4×4 RST refer to transforms applicable to a 4×4 region included in the transform coefficient block when both W and H of the target block to are equal to or greater than 4, and the 4×4 region may be a top-left 4×4 region in the transform coefficient block.

[0137] According to an embodiment of the present disclosure, for a transform in an encoding process, only 48 pieces

of data may be selected and a maximum 16×48 transform kernel matrix may be applied thereto, rather than applying a 16×64 transform kernel matrix to 64 pieces of data forming an 8×8 region. Here, "maximum" means that m has a maximum value of 16 in an $m \times 48$ transform kernel matrix for generating m coefficients. That is, when an RST is performed by applying an $m \times 48$ transform kernel matrix ($m \leq 16$) to an 8×8 region, 48 pieces of data are input and m coefficients are generated. When m is 16, 48 pieces of data are input and 16 coefficients are generated. That is, assuming that 48 pieces of data form a 48×1 vector, a 16×48 matrix and a 48×1 vector are sequentially multiplied, thereby generating a 16×1 vector. Here, the 48 pieces of data forming the 8×8 region may be properly arranged, thereby forming the 48×1 vector. For example, a 48×1 vector may be constructed based on 48 pieces of data constituting a region excluding the bottom right 4×4 region among the 8×8 regions. Here, when a matrix operation is performed by applying a maximum 16×48 transform kernel matrix, 16 modified transform coefficients are generated, and the 16 modified transform coefficients may be arranged in a top-left 4×4 region according to a scanning order, and a top-right 4×4 region and a bottom-left 4×4 region may be filled with zeros.

[0138] For an inverse transform in a decoding process, the transposed matrix of the foregoing transform kernel matrix may be used. That is, when an inverse RST or LFNST is performed in the inverse transform process performed by the decoding apparatus, input coefficient data to which the inverse RST is applied is configured in a one-dimensional vector according to a predetermined arrangement order, and a modified coefficient vector obtained by multiplying the one-dimensional vector and a corresponding inverse RST matrix on the left of the one-dimensional vector may be arranged in a two-dimensional block according to a predetermined arrangement order.

[0139] In summary, in the transform process, when an RST or LFNST is applied to an 8×8 region, a matrix operation of 48 transform coefficients in top-left, top-right, and bottom-left regions of the 8×8 region excluding the bottom-right region among transform coefficients in the 8×8 region and a 16×48 transform kernel matrix. For the matrix operation, the 48 transform coefficients are input in a one-dimensional array. When the matrix operation is performed, 16 modified transform coefficients are derived, and the modified transform coefficients may be arranged in the top-left region of the 8×8 region.

[0140] On the contrary, in the inverse transform process, when an inverse RST or LFNST is applied to an 8×8 region, 16 transform coefficients corresponding to a top-left region of the 8×8 region among transform coefficients in the 8×8 region may be input in a one-dimensional array according to a scanning order and may be subjected to a matrix operation with a 48×16 transform kernel matrix. That is, the matrix operation may be expressed as $(48 \times 16 \text{ matrix}) * (16 \times 1 \text{ transform coefficient vector}) = (48 \times 1 \text{ modified transform coefficient vector})$. Here, an $n \times 1$ vector may be interpreted to have the same meaning as an $n \times 1$ matrix and may thus be expressed as an $n \times 1$ column vector. Further, * denotes matrix multiplication. When the matrix operation is performed, 48 modified transform coefficients may be derived, and the 48 modified transform coefficients may be arranged in top-left, top-right, and bottom-left regions of the 8×8 region excluding a bottom-right region.

[0141] When a secondary inverse transform is based on an RST, the inverse transformer 235 of the encoding apparatus 200 and the inverse transformer 322 of the decoding apparatus 300 may include an inverse reduced secondary transformer to derive modified transform coefficients based on an inverse RST on transform coefficients and an inverse primary transformer to derive residual samples for the target block based on an inverse primary transform on the modified transform coefficients. The inverse primary transform refers to the inverse transform of a primary transform applied to a residual. In the present disclosure, deriving a transform coefficient based on a transform may refer to deriving the transform coefficient by applying the transform.

[0142] The above-described non-separated transform, the LFNST, will be described in detail as follows. The LFNST may include a forward transform by the encoding apparatus and an inverse transform by the decoding apparatus.

[0143] The encoding apparatus receives a result (or a part of a result) derived after applying a primary (core) transform as an input, and applies a forward secondary transform (secondary transform).

[Equation 9]

$$y = G^T x$$

[0144] In Equation 9, x and y are inputs and outputs of the secondary transform, respectively, and G is a matrix representing the secondary transform, and transform basis vectors are composed of column vectors. In the case of an inverse LFNST, when the dimension of the transformation matrix G is expressed as [number of rows \times number of columns], in the case of an forward LFNST, the transposition of matrix G becomes the dimension of G^T .

[0145] For the inverse LFNST, the dimensions of matrix G are $[48 \times 16]$, $[48 \times 8]$, $[16 \times 16]$, $[16 \times 8]$, and the $[48 \times 8]$ matrix and the $[16 \times 8]$ matrix are partial matrices that sampled 8 transform basis vectors from the left of the $[48 \times 16]$ matrix and the $[16 \times 16]$ matrix, respectively.

[0146] On the other hand, for the forward LFNST, the dimensions of matrix G^T are $[16 \times 48]$, $[8 \times 48]$, $[16 \times 16]$,

$[8 \times 16]$, and the $[8 \times 48]$ matrix and the $[8 \times 16]$ matrix are partial matrices obtained by sampling 8 transform basis vectors from the top of the $[16 \times 48]$ matrix and the $[16 \times 16]$ matrix, respectively.

[0147] Therefore, in the case of the forward LFNST, a $[48 \times 1]$ vector or $[16 \times 1]$ vector is possible as an input x , and a $[16 \times 1]$ vector or a $[8 \times 1]$ vector is possible as an output y . In video coding and decoding, the output of the forward primary transform is two-dimensional (2D) data, so to construct the $[48 \times 1]$ vector or the $[16 \times 1]$ vector as the input x , a one-dimensional vector must be constructed by properly arranging the 2D data that is the output of the forward transformation.

[0148] FIG. 7 is a diagram illustrating a sequence of arranging output data of a forward primary transformation into a one-dimensional vector according to an example. The left diagrams of (a) and (b) of FIG. 7 show the sequence for constructing a $[48 \times 1]$ vector, and the right diagrams of (a) and (b) of FIG. 7 shows the sequence for constructing a $[16 \times 1]$ vector. In the case of the LFNST, a one-dimensional vector x can be obtained by sequentially arranging 2D data in the same order as in (a) and (b) of FIG. 7.

[0149] The arrangement direction of the output data of the forward primary transform may be determined according to an intra prediction mode of the current block. For example, when the intra prediction mode of the current block is in the horizontal direction with respect to the diagonal direction, the output data of the forward primary transform may be arranged in the order of (a) of FIG. 7, and when the intra prediction mode of the current block is in the vertical direction with respect to the diagonal direction, the output data of the forward primary transform may be arranged in the order of (b) of FIG. 7.

[0150] According to an example, an arrangement order different from the arrangement orders of (a) and (b) of FIG. 7 may be applied, and in order to derive the same result (y vector) as when the arrangement orders of (a) and (b) of FIG. 7 is applied, the column vectors of the matrix G may be rearranged according to the arrangement order. That is, it is possible to rearrange the column vectors of G so that each element constituting the x vector is always multiplied by the same transform basis vector.

[0151] Since the output y derived through Equation 9 is a one-dimensional vector, when two-dimensional data is required as input data in the process of using the result of the forward secondary transformation as an input, for example, in the process of performing quantization or residual coding, the output y vector of Equation 9 must be properly arranged as 2D data again.

[0152] FIG. 8 is a diagram illustrating a sequence of arranging output data of a forward secondary transform into a two-dimensional vector according to an example.

[0153] In the case of the LFNST, output values may be arranged in a 2D block according to a predetermined scan order. (a) of FIG. 8 shows that when the output y is a $[16 \times 1]$ vector, the output values are arranged at 16 positions of the 2D block according to a diagonal scan order. (b) of FIG. 8 shows that when the output y is a $[8 \times 1]$ vector, the output values are arranged at 8 positions of the 2D block according to the diagonal scan order, and the remaining 8 positions are filled with zeros. X in (b) of FIG. 8 indicates that it is filled with zero.

[0154] According to another example, since the order in which the output vector y is processed in performing quantization or residual coding may be preset, the output vector y may not be arranged in the 2D block as shown in FIG. 8. However, in the case of the residual coding, data coding may be performed in 2D block (eg, 4×4) units such as CG (Coefficient Group), and in this case, the data are arranged according to a specific order as in the diagonal scan order of FIG. 8.

[0155] Meanwhile, the decoding apparatus may configure the one-dimensional input vector y by arranging two-dimensional data output through a dequantization process or the like according to a preset scan order for the inverse transformation. The input vector y may be output as the output vector x by the following equation.

[Equation 10]

$$x = Gy$$

[0156] In the case of the inverse LFNST, an output vector x can be derived by multiplying an input vector y , which is a $[16 \times 1]$ vector or a $[8 \times 1]$ vector, by a G matrix. For the inverse LFNST, the output vector x can be either a $[48 \times 1]$ vector or a $[16 \times 1]$ vector.

[0157] The output vector x is arranged in a two-dimensional block according to the order shown in FIG. 7 and is arranged as two-dimensional data, and this two-dimensional data becomes input data (or a part of input data) of the inverse primary transformation.

[0158] Accordingly, the inverse secondary transformation is the opposite of the forward secondary transformation process as a whole, and in the case of the inverse transformation, unlike in the forward direction, the inverse secondary transformation is first applied, and then the inverse primary transformation is applied.

[0159] In the inverse LFNST, one of 8 $[48 \times 16]$ matrices and 8 $[16 \times 16]$ matrices may be selected as the trans-

formation matrix G. Whether to apply the [48 × 16] matrix or the [16 × 16] matrix depends on the size and shape of the block.

[0160] In addition, 8 matrices may be derived from four transform sets as shown in Table 2 above, and each transform set may consist of two matrices. Which transform set to use among the 4 transform sets is determined according to the intra prediction mode, and more specifically, the transform set is determined based on the value of the intra prediction mode extended by considering the Wide Angle Intra Prediction (WAIP). Which matrix to select from among the two matrices constituting the selected transform set is derived through index signaling. More specifically, 0, 1, and 2 are possible as the transmitted index value, 0 may indicate that the LFNST is not applied, and 1 and 2 may indicate any one of two transform matrices constituting a transform set selected based on the intra prediction mode value.

[0161] FIG. 9 is a diagram illustrating wide-angle intra prediction modes according to an embodiment of the present document.

[0162] The general intra prediction mode value may have values from 0 to 66 and 81 to 83, and the intra prediction mode value extended due to WAIP may have a value from -14 to 83 as shown. Values from 81 to 83 indicate the CCLM (Cross Component Linear Model) mode, and values from -14 to -1 and values from 67 to 80 indicate the intra prediction mode extended due to the WAIP application.

[0163] When the width of the prediction current block is greater than the height, the upper reference pixels are generally closer to positions inside the block to be predicted. Therefore, it may be more accurate to predict in the bottom-left direction than in the top-right direction. Conversely, when the height of the block is greater than the width, the left reference pixels are generally close to positions inside the block to be predicted. Therefore, it may be more accurate to predict in the top-right direction than in the bottom-left direction. Therefore, it may be advantageous to apply remapping, ie, mode index modification, to the index of the wide-angle intra prediction mode.

[0164] When the wide-angle intra prediction is applied, information on the existing intra prediction may be signaled, and after the information is parsed, the information may be remapped to the index of the wide-angle intra prediction mode. Therefore, the total number of the intra prediction modes for a specific block (eg, a non-square block of a specific size) may not change, and that is, the total number of the intra prediction modes is 67, and intra prediction mode coding for the specific block may not be changed.

[0165] Table 3 below shows a process of deriving a modified intra mode by remapping the intra prediction mode to the wide-angle intra prediction mode.

[Table 3]

Inputs to this process are:

- a variable predModelIntra specifying the intra prediction mode,
- a variable nTbW specifying the transform block width,
- a variable nTbH specifying the transform block height,
- a variable cldx specifying the colour component of the current block.

Output of this process is the modified intra prediction mode predModelIntra.

The variables nW and nH are derived as follows:

- If Intra.SubPartitionsSplitType is equal to ISP_NO_SPLIT of cldx is not equal to 0, the following applies:

$$nW = nTbW \quad (8-97)$$

$$nH = nTbH \quad (8-98)$$

- Otherwise (IntraSubPartitionsSplitType is not equal to ISP_NO_SPLIT and cldx is equal to), the following applies:

$$nW = nCbW \quad (8-99)$$

$$nH = nCbH \quad (8-100)$$

The variable whRatio is set equal to Abs(Log2(nW ; nH)).

For non-square blocks (nW is not equal to nH), the intra. prediction mode predModelIntra is modified as follows:

- If all of the following conditions are true, predModelIntra is set equal to (predModelIntra + 65).

- nW is greater than nH
- predModelIntra is greater than or equal to 2
- predModelIntra is less than (whRatio > 1) ? (8 + 2 * whRatio) : 8

- Otherwise, if all of the following conditions are true, predModelIntra is set equal to (predModelIntra - 67).

- nH is greater than nW
- predModelIntra is less than or equal to 66
- predModelIntra is greater than (whRatio > 1) ? (60 - 2 * whRatio) : 60

[0166] In Table 3, the extended intra prediction mode value is finally stored in the predModelIntra variable, and ISP_NO SPLIT indicates that the CU block is not divided into sub-partitions by the Intra Sub Partitions (ISP) technique currently adopted in the VVC standard, and the cldx variable Values of 0, 1, and 2 indicate the case of luma, Cb, and Cr components, respectively. Log2 function shown in Table 3 returns a log value with a base of 2, and the Abs function returns an absolute value.

[0167] Variable predModelIntra indicating the intra prediction mode and the height and width of the transform block, etc. are used as input values of the wide angle intra prediction mode mapping process, and the output value is the modified intra prediction mode predModelIntra. The height and width of the transform block or the coding block may be the height and width of the current block for remapping of the intra prediction mode. At this time, the variable whRatio reflecting the ratio of the width to the height may be set to $\text{Abs}(\text{Log}_2(nW / nH))$.

[0168] For a non-square block, the intra prediction mode may be divided into two cases and modified.

[0169] First, if all conditions (1) ~ (3) are satisfied, (1) the width of the current block is greater than the height, (2) the intra prediction mode before modifying is equal to or greater than 2, (3) the intra prediction mode is less than the value derived from $(8 + 2 * whRatio)$ when the variable whRatio is greater than 1, and is less than 8 when the variable whRatio is less than or equal to 1 [predModelIntra is less than $(whRatio > 1) ? (8 + 2 * whRatio) : 8$], the intra prediction mode is set to a value 65 greater than the intra prediction mode [predModelIntra is set equal to $(\text{predModelIntra} + 65)$].

[0170] If different from the above, that is, follow conditions (1) ~ (3) are satisfied, (1) the height of the current block is greater than the width, (2) the intra prediction mode before modifying is less than or equal to 66, (3) the intra prediction mode is greater than the value derived from $(60 - 2 * whRatio)$ when the variable whRatio is greater than 1, and is greater than 60 when the variable whRatio is less than or equal to 1 [predModelIntra is greater than $(whRatio > 1) ? (60 - 2 * whRatio) : 60$], the intra prediction mode is set to a value 67 smaller than the intra prediction mode [predModelIntra is set equal to $(\text{predModelIntra} - 67)$].

[0171] Table 2 above shows how a transform set is selected based on the intra prediction mode value extended by the WAIP in the LFNST. As shown in FIG. 9, modes 14 to 33 and modes 35 to 80 are symmetric with respect to the prediction direction around mode 34. For example, mode 14 and mode 54 are symmetric with respect to the direction corresponding to mode 34. Therefore, the same transform set is applied to modes located in mutually symmetrical directions, and this symmetry is also reflected in Table 2.

[0172] Meanwhile, it is assumed that forward LFNST input data for mode 54 is symmetrical with the forward LFNST input data for mode 14. For example, for mode 14 and mode 54, the two-dimensional data is rearranged into one-dimensional data according to the arrangement order shown in (a) of FIG. 7 and (b) of FIG. 7, respectively. In addition, it can be seen that the patterns in the order shown in (a) of FIG. 7 and (b) of FIG. 7 are symmetrical with respect to the direction (diagonal direction) indicated by Mode 34.

[0173] Meanwhile, as described above, which transform matrix of the $[48 \times 16]$ matrix and the $[16 \times 16]$ matrix is applied to the LFNST is determined by the size and shape of the transform target block.

[0174] FIG. 10 is a diagram illustrating a block shape to which the LFNST is applied. (a) of FIG. 10 shows 4×4 blocks, (b) shows 4×8 and 8×4 blocks, (c) shows $4 \times N$ or $N \times 4$ blocks in which N is 16 or more, (d) shows 8×8 blocks, (e) shows $M \times N$ blocks where $M \geq 8$, $N \geq 8$, and $N > 8$ or $M > 8$.

[0175] In FIG. 10, blocks with thick borders indicate regions to which the LFNST is applied. For the blocks of (a) and (b) of FIG. 10, the LFNST is applied to the top-left 4×4 region, and for the block of (c) of FIG. 10, the LFNST is applied individually the two top-left 4×4 regions are continuously arranged. In (a), (b), and (c) of FIG. 10, since the LFNST is applied in units of 4×4 regions, this LFNST will be hereinafter referred to as "4x4 LFNST". Based on the matrix dimension for G , a $[16 \times 16]$ or $[16 \times 8]$ matrix may be applied.

[0176] More specifically, the $[16 \times 8]$ matrix is applied to the 4×4 block (4×4 TU or 4×4 CU) of (a) of FIG. 10 and the $[16 \times 16]$ matrix is applied to the blocks in (b) and (c) of FIG. 10. This is to adjust the computational complexity for the worst case to 8 multiplications per sample.

[0177] With respect to (d) and (e) of FIG. 10, the LFNST is applied to the top-left 8×8 region, and this LFNST is hereinafter referred to as "8x8 LFNST". As a corresponding transformation matrix, a $[48 \times 16]$ matrix or $[48 \times 8]$ matrix may be applied. In the case of the forward LFNST, since the $[48 \times 1]$ vector (x vector in Equation 9) is input as input data, all sample values of the top-left 8×8 region are not used as input values of the forward LFNST. That is, as can be seen in the left order of (a) of FIG. 7 or the left order of (b) of FIG. 7, the $[48 \times 1]$ vector may be constructed based on samples belonging to the remaining 3 4×4 blocks while leaving the bottom-right 4×4 block as it is.

[0178] The $[48 \times 8]$ matrix may be applied to an 8×8 block (8×8 TU or 8×8 CU) in (d) of FIG. 10, and the $[48 \times 16]$ matrix may be applied to the 8×8 block in (e) of FIG. 10. This is also to adjust the computational complexity for the worst case to 8 multiplications per sample.

[0179] Depending on the block shape, when the corresponding forward LFNST (4x4 LFNST or 8x8 LFNST) is applied, 8 or 16 output data (y vector in Equation 9, $[8 \times 1]$ or $[16 \times 1]$ vector) is generated. In the forward LFNST, the number of output data is equal to or less than the number of input data due to the characteristics of the matrix G^T .

[0180] FIG. 11 is a diagram illustrating an arrangement of output data of a forward LFNST according to an example,

and shows a block in which output data of the forward LFNST is arranged according to a block shape.

[0181] The shaded area at the top-left of the block shown in FIG. 11 corresponds to the area where the output data of the forward LFNST is located, the positions marked with 0 indicate samples filled with 0 values, and the remaining area represents regions that are not changed by the forward LFNST. In the area not changed by the LFNST, the output data of the forward primary transform remains unchanged.

[0182] As described above, since the dimension of the transform matrix applied varies according to the shape of the block, the number of output data also varies. As FIG. 11, the output data of the forward LFNST may not completely fill the top-left 4x4 block. In the case of (a) and (d) of FIG. 11, a [16 × 8] matrix and a [48 × 8] matrix are applied to the block indicated by a thick line or a partial region inside the block, respectively, and a [8 × 1] vector as the output of the forward LFNST is generated. That is, according to the scan order shown in (b) of FIG. 8, only 8 output data may be filled as shown in (a) and (d) of FIG. 11, and 0 may be filled in the remaining 8 positions. In the case of the LFNST applied block of (d) of FIG. 10, as shown in (d) of FIG. 11, two 4x4 blocks in the top-right and bottom-left adjacent to the top-left 4x4 block are also filled with 0 values.

[0183] As described above, basically, by signaling the LFNST index, whether to apply the LFNST and the transform matrix to be applied are specified. As shown FIG. 11, when the LFNST is applied, since the number of output data of the forward LFNST may be equal to or less than the number of input data, a region filled with a zero value occurs as follows.

[0184] 1) As shown in (a) of FIG. 11, samples from the 8th and later positions in the scan order in the top-left 4x4 block, that is, samples from the 9th to the 16th.

[0185] 2) As shown in (d) and (e) of FIG. 11, when the [48 × 16] matrix or the [48 × 8] matrix is applied, two 4x4 blocks adjacent to the top-left 4x4 block or the second and third 4x4 blocks in the scan order.

[0186] Therefore, if non-zero data exists by checking the areas 1) and 2), it is certain that the LFNST is not applied, so that the signaling of the corresponding LFNST index can be omitted.

[0187] According to an example, for example, in the case of LFNST adopted in the VVC standard, since signaling of the LFNST index is performed after the residual coding, the encoding apparatus may know whether there is the non-zero data (significant coefficients) for all positions within the TU or CU block through the residual coding. Accordingly, the encoding apparatus may determine whether to perform signaling on the LFNST index based on the existence of the non-zero data, and the decoding apparatus may determine whether the LFNST index is parsed. When the non-zero data does not exist in the area designated in 1) and 2) above, signaling of the LFNST index is performed.

[0188] Since a truncated unary code is applied as a binarization method for the LFNST index, the LFNST index consists of up to two bins, and 0, 10, and 11 are assigned as binary codes for possible LFNST index values of 0, 1, and 2, respectively. In the case of the LFNST currently adopted for WC, a context-based CABAC coding is applied to the first bin (regular coding), and a bypass coding is applied to the second bin. The total number of contexts for the first bin is 2, when (DCT-2, DCT-2) is applied as a primary transform pair for the horizontal and vertical directions, and a luma component and a chroma component are coded in a dual tree type, one context is allocated and another context applies for the remaining cases. The coding of the LFNST index is shown in a table as follows.

[Table 4]

Syntax element	binIdx				
	1	2	3	4	>= 5
lfnst_idx[][]	(tu_mts_idx[x0][y0] = 0 && treeType != SINGLE_TREE) ? 1 : 0				
	bypass	na	na	na	na

[0189] Meanwhile, for the adopted LFNST, the following simplification methods may be applied.

(i) According to an example, the number of output data for the forward LFNST may be limited to a maximum of 16.

[0190] In the case of (c) of FIG. 10, the 4x4 LFNST may be applied to two 4x4 regions adjacent to the top-left, respectively, and in this case, a maximum of 32 LFNST output data may be generated. when the number of output data for forward LFNST is limited to a maximum of 16, in the case of 4xN/Nx4 (N≥16) blocks (TU or CU), the 4x4 LFNST is only applied to one 4x4 region in the top-left, the LFNST may be applied only once to all blocks of FIG. 10. Through this, the implementation of image coding may be simplified.

[0191] FIG. 12 shows that the number of output data for the forward LFNST is limited to a maximum of 16 according to an example. As FIG. 12, when the LFNST is applied to the most top-left 4x4 region in a 4xN or Nx4 block in which N is 16 or more, the output data of the forward LFNST becomes 16 pieces.

[0192] (ii) According to an example, zero-out may be additionally applied to a region to which the LFNST is not applied. In this document, the zero-out may mean filling values of all positions belonging to a specific region with a value of 0. That is, the zero-out can be applied to a region that is not changed due to the LFNST and maintains the result of the

forward primary transformation. As described above, since the LFNST is divided into the 4x4 LFNST and the 8x8 LFNST, the zero-out can be divided into two types ((ii)-(A) and (ii)-(B)) as follows.

[0193] (ii)-(A) When the 4x4 LFNST is applied, a region to which the 4x4 LFNST is not applied may be zeroed out. FIG. 13 is a diagram illustrating the zero-out in a block to which the 4x4 LFNST is applied according to an example.

[0194] As shown in FIG. 13, with respect to a block to which the 4x4 LFNST is applied, that is, for all of the blocks in (a), (b) and (c) of FIG. 11, the whole region to which the LFNST is not applied may be filled with zeros.

[0195] On the other hand, (d) of FIG. 13 shows that when the maximum value of the number of the output data of the forward LFNST is limited to 16 as shown in FIG. 12, the zero-out is performed on the remaining blocks to which the 4x4 LFNST is not applied.

[0196] (ii)-(B) When the 8x8 LFNST is applied, a region to which the 8x8 LFNST is not applied may be zeroed out. FIG. 14 is a diagram illustrating the zero-out in a block to which the 8x8 LFNST is applied according to an example.

[0197] As shown in FIG. 14, with respect to a block to which the 8x8 LFNST is applied, that is, for all of the blocks in (d) and (e) of FIG. 11, the whole region to which the LFNST is not applied may be filled with zeros.

[0198] (iii) Due to the zero-out presented in (ii) above, the area filled with zeros may be not same when the LFNST is applied. Accordingly, it is possible to check whether the non-zero data exists according to the zero-out proposed in (ii) over a wider area than the case of the LFNST of FIG. 11.

[0199] For example, when (ii)-(B) is applied, after checking whether the non-zero data exists where the area filled with zero values in (d) and (e) of Fig. 11 in addition to the area filled with 0 additionally in FIG. 14, signaling for the LFNST index can be performed only when the non-zero data does not exist.

[0200] Of course, even if the zero-out proposed in (ii) is applied, it is possible to check whether the non-zero data exists in the same way as the existing LFNST index signaling. That is, after checking whether the non-zero data exists in the block filled with zeros in FIG. 11, the LFNST index signaling may be applied. In this case, the encoding apparatus only performs the zero out and the decoding apparatus does not assume the zero out, that is, checking only whether the non-zero data exists only in the area explicitly marked as 0 in FIG. 11, may perform the LFNST index parsing.

[0201] Alternatively, according to another example, the zero-out may be performed as shown in FIG. 15. FIG. 15 is a diagram illustrating the zero-out in a block to which the 8x8 LFNST is applied according to another example.

[0202] As shown in FIGs. 13 and 14, the zero-out may be applied to all regions other than the region to which the LFNST is applied, or the zero-out may be applied only to a partial region as shown in FIG. 15. The zero-out is applied only to regions other than the top-left 8x8 region of FIG. 15, the zero-out may not be applied to the bottom-right 4x4 block within the top-left 8x8 region.

[0203] Various embodiments in which combinations of the simplification methods ((i), (ii)-(A), (ii)-(B), (iii)) for the LFNST are applied may be derived. Of course, the combinations of the above simplification methods are not limited to the following an embodiment, and any combination may be applied to the LFNST.

Embodiment

[0204]

- Limit the number of output data for forward LFNST to a maximum of 16 → (i)
- When the 4x4 LFNST is applied, all areas to which the 4x4 LFNST is not applied are zero-out → (ii)-(A)
- When the 8x8 LFNST is applied, all areas to which the 8x8 LFNST is not applied are zero-out → (ii)-(B)
- After checking whether the non-zero data exists also the existing area filled with zero value and the area filled with zeros due to additional zero outs ((ii)-(A), (ii)-(B)), the LFNST index is signaled only when the non-zero data does not exist → (iii)

[0205] In the case of the Embodiment, when the LFNST is applied, an area in which the non-zero output data can exist is limited to the inside of the top-left 4x4 area. In more detail, in the case of (a) of FIG. 13 and (a) of FIG. 14, the 8th position in the scan order is the last position where non-zero data can exist. In the case of (b) and (c) of FIG. 13 and (b) of FIG. 14, the 16th position in the scan order (ie, the position of the bottom-right edge of the top-left 4x4 block) is the last position where data other than 0 may exist.

[0206] Therefore, when the LFNST is applied, after checking whether the non-zero data exists in a position where the residual coding process is not allowed (at a position beyond the last position), it can be determined whether the LFNST index is signaled.

[0207] In the case of the zero-out method proposed in (ii), since the number of data finally generated when both the primary transform and the LFNST are applied, the amount of computation required to perform the entire transformation process can be reduced. That is, when the LFNST is applied, since zero-out is applied to the forward primary transform output data existing in a region to which the LFNST is not applied, there is no need to generate data for the region that become zero-out during performing the forward primary transform. Accordingly, it is possible to reduce the amount of

computation required to generate the corresponding data. The additional effects of the zero-out method proposed in (ii) are summarized as follows.

[0208] First, as described above, the amount of computation required to perform the entire transform process is reduced.

[0209] In particular, when (ii)-(B) is applied, the amount of calculation for the worst case is reduced, so that the transform process can be lightened. In other words, in general, a large amount of computation is required to perform a large-size primary transformation. By applying (ii)-(B), the number of data derived as a result of performing the forward LFNST can be reduced to 16 or less. In addition, as the size of the entire block (TU or CU) increases, the effect of reducing the amount of transform operation is further increased.

[0210] Second, the amount of computation required for the entire transform process can be reduced, thereby reducing the power consumption required to perform the transform.

[0211] Third, the latency involved in the transform process is reduced.

[0212] The secondary transformation such as the LFNST adds a computational amount to the existing primary transformation, thus increasing the overall delay time involved in performing the transformation. In particular, in the case of intra prediction, since reconstructed data of neighboring blocks is used in the prediction process, during encoding, an increase in latency due to a secondary transformation leads to an increase in latency until reconstruction. This can lead to an increase in overall latency of intra prediction encoding.

[0213] However, if the zero-out suggested in (ii) is applied, the delay time of performing the primary transform can be greatly reduced when LFNST is applied, the delay time for the entire transform is maintained or reduced, so that the encoding apparatus can be implemented more simply.

[0214] In the conventional intra prediction, a block to be currently encoded is regarded as one encoding unit and encoding was performed without splitting. However, intra sub-partitions (ISP) coding means performing intra prediction encoding by dividing a block to be currently encoded in a horizontal direction or a vertical direction. In this case, a reconstructed block may be generated by performing encoding/decoding in units of divided blocks, and the reconstructed block may be used as a reference block of the next divided block. According to an embodiment, in ISP coding, one coding block may be divided into two or four sub-blocks and coded, and in ISP, in one sub-block, intra prediction is performed with reference to a reconstructed pixel value of a sub-block located at the adjacent left side or adjacent upper side. Hereinafter, "coding" may be used as a concept including both coding performed by an encoding apparatus and decoding performed by a decoding apparatus.

[0215] Table 5 represents the number of sub-blocks divided according to block sizes when ISP is applied, and sub-partitions divided according to ISP may be referred to as transform blocks (TUs).

[Table 5]

Block size (CU)	Number of divisions
4x4	Not available
4x8, 8x4	2
All other cases	4

[0216] The ISP is to divide a block predicted as luma intra into two or four sub-partitions in a vertical direction or a horizontal direction according to the size of the block. For example, the minimum block size to which the ISP can be applied is 4×8 or 8×4 . When the block size is greater than 4×8 or 8×4 , the block is divided into 4 sub-partitions.

[0217] FIGS. 16 and 17 illustrate an example of a sub-block into which one coding block is divided, and more specifically, FIG. 16 illustrates an example of division of a case in which a coding block (width (W) X height (H)) is 4×8 blocks or 8×4 blocks, and FIG. 17 illustrates an example of division of a case in which a coding block is not 4×8 blocks, 8×4 blocks, or 4×4 blocks.

[0218] When ISP is applied, sub-blocks are sequentially coded, for example, horizontally or vertically, from left to right or from top to bottom according to a division type, and after a reconstruction process is performed via inverse transform and intra prediction for one sub-block, coding for the next sub-block may be performed. For the leftmost or uppermost subblock, a reconstructed pixel of the already coded coding block is referred to, as in a conventional intra prediction method. Further, when each side of a subsequent internal sub-block is not adjacent to a previous sub-block, in order to derive reference pixels adjacent to the corresponding side, reconstructed pixels of an already coded adjacent coding block are referred to, as in a conventional intra prediction method.

[0219] In the ISP coding mode, all sub-blocks may be coded with the same intra prediction mode, and a flag indicating whether to use ISP coding and a flag indicating whether to divide (horizontally or vertically) in which direction may be signaled. As illustrated in FIGS. 16 and 17, the number of sub-blocks may be adjusted to 2 or 4 according to a block shape, and when the size (width \times height) of one sub-block is less than 16, it may be restricted so that division into the

corresponding sub-block is not allowed or the ISP coding itself is not applied.

[0220] In the case of the ISP prediction mode, one coding unit is divided into two or four partition blocks, that is, sub-blocks and predicted, and the same intra prediction mode is applied to the divided two or four partition blocks.

[0221] As described above, in the division direction, the horizontal direction (when an $M \times N$ coding unit having horizontal and vertical lengths of M and N , respectively, is divided in the horizontal direction, if the $M \times N$ coding unit is divided into two, the $M \times N$ coding unit is divided into $M \times (N/2)$ blocks, and if the $M \times N$ coding unit is divided into four blocks, the $M \times N$ coding unit is divided into $M \times (N/4)$ blocks) and the vertical direction (when an $M \times N$ coding unit is divided in a vertical direction, if the $M \times N$ coding unit is divided into two, and the $M \times N$ coding unit is divided into $(M/2) \times N$ blocks, and if the $M \times N$ coding unit is divided into four, the $M \times N$ coding unit is divided into $(M/4) \times N$ blocks) are both possible. When the $M \times N$ coding unit is divided in the horizontal direction, partition blocks are coded in a top-down order, and when the $M \times N$ coding unit is divided in the vertical direction, partition blocks are coded in order from left to right. The currently coded partition block may be predicted with reference to the reconstructed pixel values of the upper (left) partition block in the case of horizontal (vertical) direction division.

[0222] A transform may be applied to a residual signal generated by the ISP prediction method in units of partition blocks. Multiple transform selection (MTS) technology based on a DST-7/DCT-8 combination as well as the existing DCT-2 may be applied to a primary transform (core transform) based on a forward direction, and a forward low frequency non-separable transform (LFNST) may be applied to transform coefficients generated according to the primary transform to generate a final modified transform coefficient.

[0223] That is, an LFNST may be applied to partition blocks divided by applying an ISP prediction mode, and the same intra prediction mode is applied to the divided partition blocks, as described above. Accordingly, when the LFNST set derived based on the intra prediction mode is selected, the derived LFNST set may be applied to all partition blocks. That is, because the same intra prediction mode is applied to all partition blocks, the same LFNST set may be applied to all partition blocks.

[0224] According to an embodiment, an LFNST may be applied only to transform blocks having both a horizontal length and a vertical length of 4 or more. Therefore, when the horizontal or vertical length of the divided partition block according to the ISP prediction method is less than 4, the LFNST is not applied and an LFNST index is not signaled. Further, when the LFNST is applied to each partition block, the corresponding partition block may be regarded as one transform block. When the ISP prediction method is not applied, the LFNST may be applied to the coding block.

[0225] A method of applying an LFNST to each partition block will be described in detail.

[0226] According to an embodiment, after a forward LFNST is applied to individual partition blocks, only maximum 16 (8 or 16) coefficients are left in the top-left 4×4 region in transform coefficient scanning order, and then zero out in which the remaining positions and regions are all filled with a value of 0 may be applied.

[0227] Alternatively, according to an embodiment, when a length of one side of the partition block is 4, the LFNST is applied only to the top-left 4×4 region, and when a length of all sides of the partition block, that is, the width and height is 8 or more, the LFNST may be applied to the remaining 48 coefficients, except for a bottom-right 4×4 region inside a top-left 8×8 region.

[0228] Alternatively, according to an embodiment, in order to adjust computational complexity of the worst case to 8 multiplications per sample, when each partition block is 4×4 or 8×8 , only 8 transform coefficients may be output after applying the forward LFNST. That is, when the partition block is 4×4 , an 8×16 matrix may be applied as a transform matrix, and when the partition block is 8×8 , an 8×48 matrix may be applied as a transform matrix.

[0229] In the current VVC standard, LFNST index signaling is performed in units of coding units. Therefore, in the ISP prediction mode and when an LFNST is applied to all partition blocks, the same LFNST index value may be applied to the corresponding partition blocks. That is, when the LFNST index value is transmitted once at a coding unit level, the corresponding LFNST index may be applied to all partition blocks in the coding unit. As described above, the LFNST index value may have values of 0, 1, and 2, where 0 represents a case in which an LFNST is not applied, and 1 and 2 indicate two transform matrices existing in one LFNST set when an LFNST is applied.

[0230] As described above, the LFNST set is determined by the intra prediction mode, and in the case of the ISP prediction mode, because all partition blocks in the coding unit are predicted in the same intra prediction mode, the partition blocks may refer to the same LFNST set.

[0231] As another example, LFNST index signaling is still performed in units of a coding unit, but in the case of the ISP prediction mode, whether to uniformly apply an LFNST to all partition blocks is not determined, and for each partition block, whether to apply the LFNST index value signaled at a coding unit level or whether not to apply the LFNST may be determined through a separate condition. Here, a separate condition may be signaled in the form of a flag for each partition block through a bitstream, and when a flag value is 1, an LFNST index value signaled at the coding unit level is applied, and when a flag value is 0, the LFNST may not be applied.

[0232] In a coding unit to which the ISP mode is applied, an example of applying an LFNST when a length of one side of the partition block is less than 4 is described as follows.

[0233] First, when the size of the partition block is $N \times 2$ ($2 \times N$), an LFNST may be applied to the top-left $M \times 2$ ($2 \times M$)

region (where $M \leq N$). For example, when $M = 8$, the top-left region becomes 8×2 (2×8) and thus a region in which 16 residual signals exist may be an input of a forward LFNST, and an $R \times 16$ ($R \leq 16$) forward transform matrix may be applied.

[0234] Here, the forward LFNST matrix may be a separate additional matrix other than the matrix included in the current VVC standard. Further, for complexity control of the worst case, an 8×16 matrix in which only upper 8 row vectors of a 16×16 matrix are sampled may be used for transformation. The complexity control method will be described in detail later.

[0235] Second, when the size of the partition block is $N \times 1$ ($1 \times N$), an LFNST may be applied to a top-left $M \times 1$ ($1 \times M$) region (where $M \leq N$). For example, when $M = 16$, the top-left region becomes 16×1 (1×16) and thus a region in which 16 residual signals exist may be an input of the forward LFNST, and an $R \times 16$ ($R \leq 16$) forward transform matrix may be applied.

[0236] Here, the corresponding forward LFNST matrix may be a separate additional matrix other than the matrix included in the current VVC standard. Further, for complexity control of the worst case, an 8×16 matrix in which only the upper 8 row vectors of the 16×16 matrix are sampled may be used for transformation. The complexity control method will be described in detail later.

[0237] The first embodiment and the second embodiment may be applied simultaneously, or either one of the two embodiments may be applied. In particular, in the case of the second embodiment, because a primary transform is considered in an LFNST, it was observed through experiments that compression performance improvement that could be obtained in the existing LFNST is relatively small compared to an LFNST index signaling cost. However, in the case of the first embodiment, compression performance improvement similar to that which could be obtained from the conventional LFNST was observed. That is, in the case of ISP, it may be checked through experiments that the application of LFNST for $2 \times N$ and $N \times 2$ contributes to an actual compression performance.

[0238] In an LFNST in the current VVC, symmetry between intra prediction modes is applied. The same LFNST set is applied to two directional modes disposed around a mode 34 (prediction in a 45 degree diagonal direction to the bottom-right), for example, the same LFNST set is applied to a mode 18 (horizontal direction prediction mode) and a mode 50 (vertical direction prediction mode). However, in modes 35 to 66, when a forward LFNST is applied, input data is transposed and then an LFNST is applied.

[0239] VVC supports a wide angle intra prediction (WAIP) mode, and an LFNST set is derived based on the modified intra prediction mode in consideration of the WAIP mode. For modes extended by WAIP, the LFNST set is determined by using symmetry, as in the general intra prediction direction mode. For example, because a mode -1 is symmetric with a mode 67, the same LFNST set is applied, and because a mode -14 is symmetric with a mode 80, the same LFNST set is applied. Modes 67 to 80 apply an LFNST transform after transposing input data before applying a forward LFNST.

[0240] In the case of the LFNST applied to the top-left $M \times 2$ ($M \times 1$) block, because the block to which the LFNST is applied is non-square, the symmetry to the LFNST cannot be applied. Therefore, instead of applying the symmetry based on the intra prediction mode, as in the LFNST of Table 2, the symmetry between the $M \times 2$ ($M \times 1$) block and the $2 \times M$ ($1 \times M$) block may be applied.

[0241] FIG. 18 is a diagram illustrating symmetry between $M \times 2$ ($M \times 1$) blocks and $2 \times M$ ($1 \times M$) blocks according to an embodiment.

[0242] As illustrated in FIG. 18, because it may be regarded that a mode 2 in the $M \times 2$ ($M \times 1$) block is symmetric with a mode 66 in the $2 \times M$ ($1 \times M$) block, the same LFNST set may be applied to the $2 \times M$ ($1 \times M$) block and the $M \times 2$ ($M \times 1$) block.

[0243] In this case, in order to apply the LFNST set applied to the $M \times 2$ ($M \times 1$) block to the $2 \times M$ ($1 \times M$) block, the LFNST set is selected based on the mode 2 instead of the mode 66. That is, before applying the forward LFNST, after transposing input data of the $2 \times M$ ($1 \times M$) block, the LFNST may be applied.

[0244] FIG. 19 is a diagram illustrating an example of transposing a $2 \times M$ block according to an embodiment.

[0245] (a) of FIG. 19 is a diagram illustrating that an LFNST may be applied by reading input data in column-first order for a $2 \times M$ block, and (b) of FIG. 19 is a diagram illustrating that an LFNST may be applied by reading input data in row-first order for an $M \times 2$ ($M \times 1$) block. A method of applying an LFNST to the top-left $M \times 2$ ($M \times 1$) or $2 \times M$ ($M \times 1$) block is described as follows.

1. First, as illustrated in (a) and (b) of FIG. 19, input data is arranged to configure an input vector of the forward LFNST. For example, referring to FIG. 18, for an $M \times 2$ block predicted in a mode 2, the order in (b) of FIG. 19 is followed, and for a $2 \times M$ block predicted in a mode 66, the input data are arranged in order of (a) of FIG. 19 and then the LFNST set for the mode 2 may be applied.

2. For the $M \times 2$ ($M \times 1$) block, the LFNST set is determined based on a modified intra prediction mode in consideration of WAIP. As described above, a preset mapping relationship is established between the intra prediction mode and the LFNST set, which may be represented by a mapping table as shown table 2.

[0246] For a $2 \times M$ ($1 \times M$) block, a symmetric mode around a prediction mode (mode 34 in the case of the VVC standard) in a 45 degree diagonal direction downward from the modified intra prediction mode in consideration of WAIP is obtained,

and then the LFNST set is determined based on the corresponding symmetric mode and the mapping table. Asymmetrical mode (y) around the mode 34 may be derived through the following equation. The mapping table will be described in more detail below.

5

【Equation 11】

if $2 \leq x \leq 66$, $y = 68 - x$,

10

otherwise ($x \leq -1$ or $x \geq 67$), $y = 66 - x$

[0247] 3. When a forward LFNST is applied, transform coefficients may be derived by multiplying input data prepared in a process 1 by an LFNST kernel. An LFNST kernel may be selected from an LFNST set determined in a process 2 and a predetermined LFNST index.

15 **[0248]** For example, when $M = 8$ and a 16×16 matrix is applied as the LFNST kernel, 16 transform coefficients may be generated by multiplying the matrix by 16 input data. The generated transform coefficients may be arranged in the top-left 8×2 or 2×8 region in scanning order used in the VVC standard.

[0249] FIG. 20 illustrates scanning order for 8×2 or 2×8 regions according to an embodiment.

20 **[0250]** All regions other than the top-left 8×2 or 2×8 region may be filled with zero values (zero-out) or the existing transform coefficients to which a primary transform is applied may be maintained as they are. The predetermined LFNST index may be one of the LFNST index values (0, 1, 2) attempted when calculating an RD cost while changing the LFNST index value in an encoding process.

25 **[0251]** In the case (e.g., 8 multiplications/samples) of a configuration that adjusts computational complexity for the worst case to a certain level or less, for example, after generating only 8 transform coefficients by multiplying an 8×16 matrix that takes only the upper 8 rows of the 16×16 matrix, 8 transform coefficients may be disposed in scanning order of FIG. 20, and zero-out may be applied to the remaining coefficient regions. The complexity control for the worst case will be described later.

30 **[0252]** 4. When applying an inverse LFNST, a preset number (e.g., 16) of transform coefficients are set as input vectors, and the LFNST set obtained from a process 2 and the LFNST kernel (e.g., 16×16 matrix) derived from the parsed LFNST index are selected and then by multiplying the LFNST kernel and the corresponding input vector, the output vector may be derived.

[0253] In the case of an $M \times 2$ ($M \times 1$) block, the output vectors may be disposed in row-first order of (b) of FIG. 19, and in the case of the $2 \times M$ ($1 \times M$) block, the output vectors may be disposed in column-first order of (a) of FIG. 19.

35 **[0254]** The remaining regions, except for a region in which the corresponding output vector is disposed within the top-left $M \times 2$ ($M \times 1$) or $2 \times M$ ($M \times 2$) region and a region other than the top-left $M \times 2$ ($M \times 1$) or $2 \times M$ ($M \times 2$) region in the partition block may be all zero-out with zero values or may be configured to maintain reconstructed transform coefficients as they are through residual coding and inverse quantization processes.

40 **[0255]** When configuring the input vector, as in No. 3, input data may be arranged in scanning order of FIG. 20, and in order to control computational complexity for the worst case to a certain level or less, an input vector may be configured by reducing the number of input data (e.g., 8 instead of 16).

[0256] For example, when $M = 8$, if 8 input data are used, only the left 16×8 matrix may be taken from the corresponding 16×16 matrix and multiplied to obtain 16 output data. The complexity control for the worst case will be described later.

45 **[0257]** In the above embodiment, when applying LFNST, a case in which symmetry is applied between an $M \times 2$ ($M \times 1$) block and a $2 \times M$ ($1 \times M$) block is presented, but according to another example, different LFNST sets may be applied to each of two block shapes.

[0258] Hereinafter, various examples of an LFNST set configuration for the ISP mode and a mapping method using the intra prediction mode will be described.

50 **[0259]** In the case of an ISP mode, the LFNST set configuration may be different from the existing LFNST set. In other words, kernels different from the existing LFNST kernels may be applied, and a mapping table different from the mapping table between an intra prediction mode index applied to the current VVC standard and the LFNST set may be applied. A mapping table applied to the current VVC standard may be the same as that of Table 2.

[0260] In Table 2, a preModelIntra value means an intra prediction mode value changed in consideration of WAIP, and an lfnstTrSetIdx value is an index value indicating a specific LFNST set. Each LFNST set is configured with two LFNST kernels.

55 **[0261]** When the ISP prediction mode is applied, if both a horizontal length and a vertical length of each partition block are equal to or greater than 4, the same kernels as the LFNST kernels applied in the current VVC standard may be applied, and the mapping table may be applied as it is. A mapping table and LFNST kernels different from the current VVC standard may be applied.

[0262] When the ISP prediction mode is applied, when a horizontal length or a vertical length of each partition block is less than 4, a mapping table and LFNST kernels different from those in the current VVC standard may be applied. Hereinafter, Tables 6 to 8 represent mapping tables between an intra prediction mode value (intra prediction mode value changed in consideration of WAIP) and an LFNST set, which may be applied to an Mx2 (Mx1) block or a 2xM (1xM) block.

5

[Table 6]

predModelIntra	lfnstTrSetIdx
predModelIntra < 0	1
0 <= predModelIntra <= 1	0
2 <= predModelIntra <= 12	1
13 <= predModelIntra <= 23	2
24 <= predModelIntra <= 34	3
35 <= predModelIntra <= 44	4
45 <= predModelIntra <= 55	5
56 <= predModelIntra <= 66	6
67 <= predModelIntra <= 80	6
81 <= predModelIntra <= 83	0

10

15

20

25

[Table 7]

predModelIntra	lfnstTrSetIdx
predModelIntra < 0	1
0 <= predModelIntra <= 1	0
2 <= predModelIntra <= 23	1
24 <= predModelIntra <= 44	2
45 <= predModelIntra <= 66	3
67 <= predModelIntra <= 80	3
81 <= predModelIntra <= 83	0

30

35

40

[Table 8]

predModelIntra	lfnstTrSetIdx
predModelIntra < 0	1
0 <= predModelIntra <= 1	0
2 <= predModelIntra <= 80	1
81 <= predModelIntra <= 83	0

45

[0263] A first mapping table of Table 6 is configured with seven LFNST sets, a mapping table of Table 7 is configured with four LFNST sets, and a mapping table of Table 8 is configured with two LFNST sets. As another example, when it is configured with one LFNST set, an lfnstTrSetIdx value may be fixed to 0 with respect to the preModelIntra value.

[0264] Hereinafter, a method of maintaining the computational complexity for the worst case when LFNST is applied to the ISP mode will be described.

[0265] In the case of an ISP mode, when LFNST is applied, in order to maintain the number of multiplications per sample (or per coefficient, per position) to a certain value or less, the application of LFNST may be limited. According to the size of the partition block, the number of multiplications per sample (or per coefficient, per position) may be maintained to 8 or less by applying LFNST as follows.

1. When both a horizontal length and a vertical length of the partition block are 4 or more, the same method as a calculation complexity control method for the worst case for LFNST in the current VVC standard may be applied.

[0266] That is, when the partition block is a 4x4 block, instead of a 16x16 matrix, an 8x16 matrix obtained by sampling the top 8 rows from a 16x16 matrix may be applied in a forward direction, and a 16x8 matrix obtained by sampling the left 8 columns from a 16x16 matrix may be applied in a reverse direction. Further, when the partition block is 8x8 blocks, in the forward direction, instead of a 16x48 matrix, an 8x48 matrix obtained by sampling the top 8 rows from a 16x48 matrix is applied, and in the reverse direction, instead of a 48x16 matrix, a 48x8 matrix obtained by sampling the left 8 columns from a 48x16 matrix may be applied.

[0267] In the case of a 4xN or Nx4 ($N > 4$) block, when a forward transform is performed, 16 coefficients generated after applying a 16x16 matrix to only the top-left 4x4 block may be disposed in the top-left 4x4 region, and other regions may be filled with a value of 0. Further, when performing an inverse transform, 16 coefficients located in the top-left 4x4 block are disposed in scanning order to form an input vector, and then 16 output data may be generated by multiplying the 16x16 matrix. The generated output data may be disposed in the top-left 4x4 region, and the remaining regions, except for the top-left 4x4 region, may be filled with a value of 0.

[0268] In the case of an 8xN or Nx8 ($N > 8$) block, when the forward transform is performed, 16 coefficients generated after applying the 16x48 matrix to only an ROI region (the remaining regions excluding bottom-right 4x4 blocks from the top-left 8x8 blocks) inside the top-left 8x8 blocks may be disposed in the top-left 4x4 region, and all other regions may be filled with a value of 0. Further, when performing an inverse transform, 16 coefficients located in the top-left 4x4 block are disposed in scanning order to form an input vector, and then 48 output data may be generated by multiplying the input vector by a 48x16 matrix. The generated output data may be filled in the ROI region, and all other regions may be filled with a value of 0.

[0269] 2. When the size of the partition block is Nx2 or 2xN and LFNST is applied to the top-left Mx2 or 2xM region ($M \leq N$), a matrix sampled according to the N value may be applied.

[0270] In the case of $M = 8$, for a partition block of $N = 8$, that is, an 8x2 or 2x8 block, an 8x16 matrix obtained by sampling the top 8 rows from a 16x16 matrix may be applied instead of a 16x16 matrix in the case of a forward transform, and in the case of an inverse transform, instead of a 16x16 matrix, a 16x8 matrix obtained by sampling left 8 columns from the 16x16 matrix may be applied.

[0271] When N is greater than 8, 16 output data generated after applying the 16x16 matrix to the top-left 8x2 or 2x8 block in the case of a forward transform are disposed in the top-left 8x2 or 2x8 block, and the remaining regions may be filled with a value of 0. In the case of an inverse transform, 16 coefficients located in the top-left 8x2 or 2x8 block are disposed in the scanning order to form an input vector, and then 16 output data may be generated by multiplying the 16x16 matrix. The generated output data may be disposed in the top-left 8x2 or 2x8 block, and all remaining regions may be filled with a value of 0.

[0272] 3. When the size of the partition block is Nx1 or 1xN and LFNST is applied to the top-left Mx1 or 1xM region ($M \leq N$), a matrix sampled according to the N value may be applied.

[0273] When $M = 16$, for a partition block of $N = 16$, that is, a 16x1 or 1x16 block, instead of a 16x16 matrix, an 8x16 matrix obtained by sampling the top 8 rows from a 16x16 matrix may be applied in the case of a forward transform, and in the case of an inverse transform, instead of a 16x16 matrix, a 16x8 matrix obtained by sampling the left 8 columns from the 16x16 matrix may be applied.

[0274] When N is greater than 16, 16 output data generated after applying the 16x16 matrix to the top-left 16x1 or 1x16 block in the case of a forward transform may be disposed in the top-left 16x1 or 1x16 block, and the remaining regions may be filled with a value of 0. In the case of an inverse transform, 16 coefficients located in the top-left 16x1 or 1x16 block may be disposed in scanning order to form an input vector, and then 16 output data may be generated by multiplying the 16x16 matrix. The generated output data may be disposed in the top-left 16x1 or 1x16 block, and all remaining regions may be filled with a value of 0.

[0275] As another example, in order to maintain the number of multiplications per sample (or per coefficient, per position) to a certain value or less, the number of multiplications per sample (or per coefficient, per position) based on the ISP coding unit size rather than the size of the ISP partition block may be maintained to 8 or less. When there is only one block satisfying the condition to which LFNST is applied among the ISP partition blocks, the complexity calculation for the worst case of LFNST may be applied based on the corresponding coding unit size rather than the size of the partition block. For example, when a luma coding block for a certain coding unit is divided into four partition blocks that are 4x4 in size and coded by ISP and a non-zero transform coefficient does not exist with respect to two partition blocks among the four partition blocks, it may be configured so that not eight transformation coefficients but 16 transformation coefficients are generated with respect to the other two partitions blocks (based on the encoder).

[0276] Hereinafter, a method of signaling an LFNST index in the ISP mode will be described.

[0277] As described above, the LFNST index may have the value of any one of 0, 1, and 2, where the value of 0 indicates that LFNST is not applied and the values of 1 and 2 respectively indicate two LFNST kernel matrices included

in a selected LFNST set. LFNST is applied based on an LFNST kernel matrix selected by the LFNST index. A method for transmitting an LFNST index in the current VVC standard will be described as follows.

1. The LFNST index may be transmitted once for each coding unit (CU), and in the case of a dual-tree type, individual LFNST indices may be signaled with respect to a luma block and a chroma block.

2. When the LFNST index is not signaled, the value of the LFNST index is set (inferred) to a default value of 0. The cases where the value of the LFNST index is inferred to be 0 are as follows:

A. A case where a mode in which transform is not applied (e.g., transform skip, BDPCM, lossless coding, etc.) is used.

B. A case where primary transformation is not DCT-2 (DST7 or DCT8), that is, a case where transformation in a horizontal direction or transformation in a vertical direction is not DCT-2.

C. A case where the horizontal length or vertical length of a luma block of a coding unit exceeds a maximum luma transformable size, for example, where the largest luma transformable size is 64, LFNST cannot be applied when the size of the luma block of the coding block is 128x16.

[0278] In the case of a dual-tree type, it is determined whether the maximum luma transformable size is exceeded with respect to each of the coding unit for the luma component and the coding unit for the chroma component. That is, it is checked whether the maximum luma transformable size is exceeded with respect to the luma block, and it is checked whether the horizontal/vertical length of a corresponding luma block for a color format and the maximum luma transformable size are exceeded with respect to a chroma block. For example, when the color format is 4:2:0, the horizontal/vertical length of the corresponding luma block is twice that of the chroma block and the transform size of the corresponding luma block is twice that of the chroma block. In another example, when the color format is 4:4:4, the horizontal/vertical length and the transform size of the corresponding luma block are the same as those of the chroma block.

[0279] A 64-length transformation or a 32-length transformation means a transformation applied horizontally or vertically having a length of 64 or 32, respectively, and "transform size" may mean a corresponding length of 64 or 32.

[0280] In the case of a single-tree type, it may be checked whether a horizontal length or a vertical length of a luma block exceeds a maximum transformable size of a luma transform block, and when the horizontal length or the vertical length of the luma block exceeds the maximum transformable size of the luma transform block, the signaling of the LFNST index may be omitted.

[0281] D. It is possible to transmit the LFNST index only when both the horizontal length and the vertical length of the coding unit are each greater than or equal to 4.

[0282] In the case of a dual-tree type, it is possible to signal the LFNST index only when both the horizontal length and the vertical length of a corresponding component (i.e., a luma or chroma component) are each greater than or equal to 4.

[0283] In the case of a single-tree type, it is possible to signal the LFNST index when both the horizontal length and the vertical length of a luma component are each greater than or equal to 4.

[0284] E. In a case where the last non-zero coefficient position is not a DC position (which is a position at the top-left of the block), the LFNST index is transmitted if the last non-zero coefficient position is not the DC position with respect to a luma block of the dual-tree type. In the case of a chroma block of the dual-tree type, the corresponding LFNST index is transmitted if any one of the last non-zero coefficient position for Cb and the last non-zero coefficient position for Cr is not the DC position.

[0285] In the case of a single-tree type, when the last non-zero coefficient position of any one of a luma component, a Cb component, and a Cr component is not a DC position, the LFNST index is transmitted.

[0286] Here, when a coded block flag (CBF) value indicating whether a transform coefficient for one transform block exists is 0, the last non-zero coefficient position for the corresponding transform block is not checked to determine whether to signal the LFNST index. That is, when the corresponding CBF value is 0, transform is not applied to the corresponding block, and thus, the position of the last non-zero coefficient may not be considered at a time when checking the condition for LFNST index signaling.

[0287] For example, 1) in the case of a luma component of the dual-tree type, if the corresponding CBF value is 0, the LFNST index is not signaled; 2) in the case of a chroma component of the dual-tree type, if the CBF value for Cb is 0 and the CBF value for Cr is 1, only the last non-zero coefficient position for Cr is checked and the corresponding LFNST index is transmitted; and 3) in the case of the single-tree type, the last non-zero coefficient position for any component having the CBF value of 1 among luma, Cb, and Cr components are checked.

[0288] F. When it is found that the transform coefficient exists at a position other than a position where an LFNST transform coefficient is allowed to exist, the signaling of the LFNST index may be omitted. In the case of a 4x4 transform block and an 8x8 transform block, LFNST transform coefficients may exist at 8 positions from the DC position according to a transform coefficient scanning order in the VVC standard and all the remaining positions are filled with 0. In addition,

in cases other than the 4×4 transform block and the 8×8 transform block, LFNST transform coefficients may exist at 16 positions from the DC position according to the transform coefficient scanning order in the VVC standard and other remaining positions are all filled with 0.

[0289] Therefore, when a non-zero transform coefficient exists in a region which should be filled with 0 after residual coding is performed, LFNST index signaling may be omitted.

[0290] Meanwhile, the ISP mode may be applied only to the luma block or may be applied to both the luma block and the chroma block. As described above, when ISP prediction is applied, the corresponding coding unit is divided into two or four partition blocks and predicted, and a transform may be applied to each of the corresponding partition blocks. Therefore, when determining a condition for signaling the LFNST index in units of coding units, it is necessary to consider the fact that LFNST is applicable to each of the respective partition blocks. In addition, when the ISP prediction mode is applied only to a specific component (e.g., a luma block), the LFNST index should be signaled in consideration of the fact that only the corresponding component is divided into partition blocks. LFNST index signaling methods available in the ISP mode may be summarized as follows.

1. The LFNST index may be transmitted once for each coding unit (CU), and in the case of the dual-tree type, an individual LFNST index may be signaled with respect to a luma block and a chroma block, respectively.
2. When the LFNST index is not signaled, the value of LFNST index is set (inferred) to a default value of 0. The cases where the LFNST index value is inferred to be 0 are as follows.

- A. A case where a mode in which transform is not applied (e.g., transform skip, BDPCM, lossless coding, etc.) is used.
- B. In a case where the horizontal length or vertical length of a luma block of a coding unit exceeds a maximum luma transformable size, for example, a case where the largest luma transformable size is 64, LFNST cannot be applied when the size of the luma block of the coding block is 128×16 .

[0291] Whether to signal the LFNST index may be determined based on the size of a partition block instead of a coding unit. That is, when the horizontal length or the vertical length of a partition block for the corresponding luma block exceeds the maximum luma transformable size, LFNST index signaling may be omitted and the value of the LFNST index may be inferred to be 0.

[0292] In the case of the dual-tree type, it is determined whether the maximum transform block size is exceeded with respect to each of the coding unit or partition block for the luma component and the coding unit or partition block for the chroma component. That is, the horizontal length and the vertical length of the coding unit or partition block for luma are compared with the maximum luma transformable size, and if any one of the horizontal length and the vertical length is greater than the maximum luma transformable size, LFNST is not applied, and, in the case of a coding unit or partition block for chroma, the horizontal/vertical length of the corresponding luma block for a color format and the maximum luma transformable size are compared. For example, when the color format is 4:2:0, the horizontal/vertical length of the corresponding luma block is twice that of the chroma block and the transform size of the corresponding luma block is twice that of the chroma block. In another example, when the color format is 4:4:4, the horizontal/vertical length and the transform size of the corresponding luma block are the same as those of the chroma block.

[0293] In the case of the single-tree type, it may be checked if the horizontal length or the vertical length of a luma block (coding unit or partition block) exceeds the maximum transformable size of a luma transform block, and if so, LFNST index signaling may be omitted.

[0294] C. When LFNST included in the current VVC standard is applied, the LFNST index may be transmitted only when both the horizontal length and the vertical length of a partition block are each greater than or equal to 4.

[0295] When LFNST for a $2 \times M$ ($1 \times M$) or $M \times 2$ ($M \times 1$) block is applied in addition to the LFNST included in the current VVC standard, the LFNST index may be transmitted only when the size of a partition block is equal to or greater than the $2 \times M$ ($1 \times M$) or $M \times 2$ ($M \times 1$) block. Here, if a $P \times Q$ block is equal to or greater than an $R \times S$ block, it means that $P \geq R$ and $Q \geq S$.

[0296] In summary, the LFNST index may be transmitted only when a partition block is equal to or greater than a minimum size to which LFNST is applicable. In the case of the dual-tree type, the LFNST index may be signaled only when a partition block for a luma or chroma component is equal to or greater than the minimum size to which the LFNST is applicable. In the case of the single-tree type, the LFNST index may be signaled only when a partition block for the luma component is equal to or greater than the minimum size to which the LFNST is applicable.

[0297] In this document, if an $M \times N$ block is greater than or equal to a $K \times L$ block, it means that M is greater than or equal to K and N is greater than or equal to L . If an $M \times N$ block is greater than a $K \times L$ block, it means that M is greater than K or N is greater than L . If an $M \times N$ block is less than or equal to a $K \times L$ block, it means that M is less than or equal to K and N is less than or equal to L , and if the $M \times N$ block is less than the $K \times L$ block, it means that M is less than or equal to K , that N is less than or equal to L , and that M is less than K or N is less than L .

[0298] D. In a case where the last non-zero coefficient position is not the DC position (which is a position at the top-left of the block), the LFNST index may be transmitted if the last non-zero coefficient position in any one of all partition blocks is not a DC location with respect to a luma block of a dual-tree type. In the case of a chroma block of the dual-tree type, the number of partition blocks is considered one) is not the DC position, the corresponding LFNST index may be transmitted if any one of the last non-zero coefficient position for all partition blocks for Cb (when the ISP mode is not applied to a chroma component, the number of partition blocks is considered one) and the last non-zero coefficient position for all partition blocks for Cr (when the ISP mode is not applied to a chroma component).

[0299] In the case of the single-tree type, when the last non-zero coefficient position for any one of all partition blocks for a luma component, a Cb component, and a Cr component is not the DC position, a corresponding LFNST index may be transmitted.

[0300] Here, when a coded block flag (CBF) value indicating whether a transform coefficient exists with respect to each partition block is 0, the last non-zero coefficient position for a corresponding partition block is not checked to determine whether to signal the LFNST index. That is, when the corresponding CBF value is 0, a transform is not applied to the corresponding block, and thus, the last non-zero coefficient position for the corresponding partition block is not considered at a time when checking the condition for LFNST index signaling.

[0301] For example, 1) in the case of a luma component of the dual-tree type, when the corresponding CBF value for each partition block is 0, a corresponding partition block is excluded when determining whether to signal the LFNST index; 2) in the case of a chroma component of the dual-tree type, when the CBF value for Cb for each partition block is 0 and the CBF value for Cr is 1, only the last non-zero coefficient position for Cr is checked when determining whether to signal the LFNST index; and 3) in the case of the single-tree type, it is possible to determine whether to signal the LFNST index by checking the last non-zero coefficient position only for blocks having the CBF value of 1 for all partition blocks of a luma component, a Cb component, and a Cr component.

[0302] In the case of the ISP mode, image information may be configured so that the last non-zero coefficient position is not checked, and an embodiment thereof is as follows.

i. In the case of the ISP mode, LFNST index signaling may be allowed without checking the last non-zero coefficient position for both the luma block and the chroma block. That is, even when the last non-zero coefficient position for all partition blocks is located at the DC position or a corresponding CBF value is 0, corresponding LFNST index signaling may be allowed.

ii. In the case of the ISP mode, it may be possible to omit the checking of the last non-zero coefficient position only for the luma block and to check the last non-zero coefficient position for the chroma block in the above-described manner. For example, in the case of a luma block of the dual-tree type, LFNST index signaling is allowed without checking the last non-zero coefficient position, and in the case of a chroma block of the dual-tree type, it may be determined whether to signal a corresponding LFNST index by checking, in the above manner, whether a DC position for the last non-zero coefficient position exists.

iii. In the case of the ISP mode and the single-tree type, the above-described method i or the above-described method ii may be applied. That is, in a case where the method i is applied to the single-tree type in the ISP mode, it is possible to omit the checking of the last non-zero coefficient position with respect to both the luma block and the chroma block and to allow LFNST index signaling. Alternatively, in the case of the application of the method ii, it is possible to omit the checking of the last non-zero coefficient position with respect to the partition blocks for the luma component, and it is possible to check the last non-zero coefficient position in the above-described manner with respect to the partition blocks for the chroma component (when ISP is not applied to the chroma component, the number may be considered to be 1) so as to determine whether to signal a corresponding LFNST index.

[0303] E. When it is found that a transform coefficient exists at a position other than a position where the LFNST transform coefficient can exist with respect even to one partition block among all partition blocks, the LFNST index signaling may be omitted.

[0304] For example, In the case of a 4x4 partition block and an 8x8 partition block, LFNST transform coefficients may exist at 8 positions from the DC position according to the transform coefficient scanning order in the VVC standard, and all the remaining positions are filled with 0. In addition, when a partition block is equal to or greater than 4x4 and is neither a 4x4 partition block nor an 8x8 partition block, LFNST transform coefficients may exist at 16 positions from the DC position according to the transform coefficient scanning order in the VVC standard, and all the remaining positions are filled with 0.

[0305] Therefore, when a non-zero transform coefficient exists in a region which should be filled with 0 after residual coding is performed, LFNST index signaling may be omitted.

[0306] When LFNST is applicable with respect even to a partition block of 2xM (1xM) or Mx2 (Mx1), a region in which LFNST transform coefficients is allowed to be located may be designated as follows. A region outside the region where the transform coefficients are allowed to be located may be filled with 0, and in the assumption that LFNST is

applied, when non-zero transform coefficients exist in the region that should be filled with 0, LFNST index signaling may be omitted.

5 i. When LFNST is applicable to a $2 \times M$ or $M \times 2$ block and $M = 8$, only 8 LFNST transform coefficients may be generated with respect to a 2×8 or 8×2 partition block. When the transform coefficients are arranged in the scanning order as shown in FIG. 20, 8 transform coefficients may be arranged in the scanning order from the DC position and the remaining 8 positions may be filled with 0.

10 With respect to a $2 \times N$ or $N \times 2$ ($N > 8$) partition block, 16 LFNST transform coefficients may be generated, and when the transform coefficients are arranged in the scanning order as shown in FIG. 20, 16 transform coefficients may be arranged in the scanning order from the DC position and the remaining region may be filled with 0. That is, a region other than the top-left 2×8 or 8×2 block in the $2 \times N$ or $N \times 2$ ($N > 8$) partition block may be filled with 0. With respect even to a 2×8 or 8×2 partition block, 16 transform coefficients instead of 8 LFNST transform coefficients may be generated, and in this case, a region that must be filled with 0 does not occur. As described above, in a case where LFNST is applied, when it is detected that a non-zero transform coefficient exists in a region set to be filled with 0 with respect even to one partition block, LFNST index signaling may be omitted and the LFNST index may be inferred to be 0.

15 ii. In a case where LFNST is applicable to a $1 \times M$ or $M \times 1$ block and $M = 16$, only 8 LFNST transform coefficients may be generated with respect to a 1×16 or 16×1 partition block. When the transform coefficients are arranged in the scanning order from left to right or from top to bottom, 8 transform coefficients may be arranged in the corresponding scanning order from the DC position, and the remaining 8 positions may be filled with 0.

20 **[0307]** With respect to a $1 \times N$ or $N \times 1$ ($N > 16$) partition block, 16 LFNST transform coefficients may be generated, and when the transform coefficients are arranged in a left-to-right or top-to-bottom scanning order, the 16 transform coefficients may be arranged from the DC position in the corresponding scanning order and the remaining regions may be filled with 0. That is, a region other than the top-left 1×16 or 16×1 block in a $1 \times N$ or $N \times 1$ ($N > 16$) partition block may be filled with 0.

25 **[0308]** 16 transform coefficients instead of 8 LFNST transform coefficients may be generated with respect even to the 1×16 or 16×1 partition block, and in this case, a region that must be filled with 0 does not occur. As described above, in a case where LFNST is applied, when it is detected that a non-zero transform coefficient exists in a region set to be filled with 0 with respect even to one partition block, LFNST index signaling may be omitted and the LFNST index may be inferred to be 0.

30 **[0309]** Meanwhile, in the case of the ISP mode, according to the current VVC standard, horizontal and vertical directions are independently regarded as length conditions and DST-7 instead of DCT-2 is applied without signaling of an MTS index. It is determined whether a horizontal or vertical length is greater than or equal to 4 and greater than or equal to 16, and a primary transform kernel is decided based on a result of the determination. Therefore, for a case where LFNST is applicable in the ISP mode, the following combinations of transform are possible.

35 1. When the LFNST index is 0 (including a case where the LFNST index is inferred to be 0), a primary transform determining condition in the ISP mode, the condition which is included in the current VVC standard, may be followed. That is, if a length condition (which is a condition of being equal to or greater than 4 and equal to or less than 16) is satisfied with respect to the horizontal direction and the vertical direction, respectively and independently; if so, DST-7 instead of DCT-2 may be applied, and if not, DCT-2 may be applied.

40 2. When the LFNST index is greater than 0, the following two configurations may be possible as primary transform.

45 A. DCT-2 may be applied to both the horizontal direction and the vertical direction.

B. A condition for determining primary transform in the ISP mode, the condition which is included in the current VVC standard, may be followed. In other words, it is checked if a length condition (which is a condition of being equal to or greater than 4 and equal to or less than 16) is satisfied with respect to the horizontal direction and the vertical direction, respectively and independently; if so, DST-7 instead of DCT-2 may be applied, and if not, DCT-2 may be applied.

50 **[0310]** In the ISP mode, image information may be configured so that the LFNST index is transmitted with respect to each partition block instead of each coding unit. In this case, in the above-described LFNST index signaling method, considering that only one partition block exists in a unit in which the LFNST index is transmitted, it may be determined whether to signal the LFNST index may be determined.

55 **[0311]** Meanwhile, according to one embodiment, in the ISP mode as shown in FIG. 9, an LFNST kernel consisting of three sets may be applied.

[0312] In cases other than the ISP mode, a mapping table like the following table may be applied, and the LFNST set as in Table 9 may be applied even when LFNST is applied in the ISP mode.

[Table 9]

predModelIntra	lfnstTrSetIdx
predModelIntra < 0	One
0 <= predModelIntra <= 1	0
2 <= predModelIntra <= 18	One
19 <= predModelIntra <= 49	3
50 <= predModelIntra <= 80	One
81 <= predModelIntra <= 83	0

[0313] The value of preModelIntra in Table 9 indicates an intra prediction mode value that has been changed in consideration of WAIP, and the value of lfnstTrSetIdx is an index value indicating a specific LFNST set, and each LFNST set consists of two LFNST kernels. Each index (lfnstTrSetIdx) may specify a corresponding LFNST set included in the VVC standard document (JVET-O2001-vE.docx) (which refers to an LFNST set specified by the lfnstTrSetIdx variable in the Low frequency non-separable transformation matrix derivation process chapter of the corresponding document).

[0314] In a case where LFNST is applied in the ISP mode, the mapping table as shown in Table 9 may be applied only when both the horizontal length and the vertical length of an ISP partition block are greater than 4.

[0315] Embodiments to which LFNST is applied in the above-described ISP mode are summarized as follows.

- (1) When LFNST is applied in the ISP mode, a transform unit to be divided must have the size of at least 4X4.
- (2) The same LFNST kernel as the existing LFNST kernel applied to a coding unit to which the ISP mode is not applied may be used.
- (3) Every transform unit must satisfy a maximum last position value condition (which is the condition for the position of the last non-zero coefficient). When one or more transform units do not satisfy the maximum last position value condition, LFNST is not used and the LFNST index is not parsed.
- (4) When the ISP mode is applied, the setting that the LFNST is applicable only when a significant coefficient exists at a position other than the DC position may be ignored.
- (5) When LFNST is applied, DCT-2 may be used for primary transform of a transform unit to which ISP is applied.

[0316] Table 10 below shows syntax elements including the above content.

[Table 8]

LfnstDcOnly = 1
LfnstZeroOutSigCoeffFlag = 1
transform_tree(x0, y0, cbWidth, cbHeight, treeType)
lfnstWidth = (treeType == DUAL_TREE_CHROMA) ? cbWidth / SubWidthC : ((IntraSubPartitionsSplitType == ISP_VER_SPLIT) ? cbWidth / NumIntraSubPartitions: cbWidth)
lfnstHeight = (treeType == DUAL_TREE_CHROMA) ? cbHeight / SubHeightC : ((IntraSubPartitionsSplitType == ISP_HOR_SPLIT) ? cbHeight / NumIntraSubPartitions: cbHeight)
if(Min(lfnstWidth, lfnstHeight) >= 4 && sps_lfnst_enabled_flag == 1 && CuPredMode[chType][x0][y0] == MODE_INTRA && (lintra_mip_flag[x0][y0] Min(lfnstWidth, lfnstHeight) >= 16) && tu_mts_idx[x0][y0] == 0 && Max(cbWidth, cbHeight) <= MaxTbSizeY) {
if((IntraSubPartitionsSplitType != ISP_NO_SPLIT LfnstDcOnly == 0) && LfnstZeroOutSigCoeffFlag == 1)
lfnst_idx[x0][y0]
}

[0317] In Table 10, the width and height of a region to which LFNST is applied according to a tree type are set and conditions for transmitting the LFNST index are shown. The syntax elements of Table 10 may be signaled at a coding unit (CU) level. In the case of the dual-tree type, individual LFNST indices for the luma block and the chroma block may be signaled.

[0318] First, when the tree type for a coding unit is dual-tree chroma, a width (lfnstWidth) of a region to which LFNST is applied may be set to a width in which the color format is reflected in the width of the coding unit ((treeType == DUAL_TREE_CHROMA) ? cbWidth / SubWidthC).

[0319] On the other hand, when the tree type for a coding unit is not dual-tree chroma but a dual-tree or single-tree luma, the width (lfnstWidth) of the region to which LFNST is applied may be set to a value obtained by dividing the coding unit by the number of sub-partitions or to the width of the coding unit according to whether the coding unit is divided by the ISP ((IntraSubPartitionsSplitType == ISP_VER_SPLIT) ? cbWidth / NumIntraSubPartitions : cbWidth). That is, if the coding unit is vertically divided by the ISP (IntraSubPartitionsSplitType == ISP_VER_SPLIT), the width of the region to which LFNST is applied may be set to a value (cbWidth / NumIntraSubPartitions) obtained by dividing the coding unit by the number of sub-partitions; if not, the width of the region to which LFNST is applied may be set to the width (cbWidth) of the coding unit.

[0320] Similarly, when the tree type for the coding unit is dual-tree chroma, a height (lfnstHeight) of the region to which LFNST is applied may be set to a height in which the color format is reflected in the height of the coding unit ((treeType == DUAL_TREE_CHROMA) ? cbHeight / SubHeightC).

[0321] On the other hand, when the tree type for the coding unit is not dual-tree chroma but dual-tree or single-tree luma, the height (lfnstHeight) of the region to which LFNST is applied may be set to a value obtained by dividing the coding unit by the number of sub-partitions or to the height of the coding unit according to whether the coding unit is divided by the ISP ((IntraSubPartitionsSplitType == ISP_HOR_SPLIT) ? cbHeight / NumIntraSubPartitions : cbHeight). That is, if the coding unit is divided in the horizontal direction by the ISP (IntraSubPartitionsSplitType == ISP_HOR_SPLIT), the height of the region to which the LFNST is applied may be set to a value (cbHeight / NumIntraSubPartitions) obtained by dividing the coding unit by the number of sub-partitions; if not, it may be set to the height (cbHeight) of the coding unit.

[0322] In order for LFNST to be applied in this way, the width and the height of the region to which the LFNST is applied must be greater than or equal to 4. That is, in the case of a coding dual-tree type, the LFNST index may be signaled only when both the horizontal length and the vertical length of a corresponding component (i.e., a luma or chroma component) are greater than or equal to 4, and in the case of a single-tree type, the LFNST index may be signaled when both the horizontal length and the vertical length of a luma component are greater than or equal to 4.

[0323] When the ISP is applied to a coding unit, the LFNST index may be transmitted only when both the horizontal length and the vertical length of a partition block are each greater than or equal to 4.

[0324] In addition, when the horizontal length or the vertical length of a luma block of a coding unit exceeds a maximum luma block transformable size (when the condition of $\text{Max}(cbWidth, cbHeight) \leq \text{MaxTbSizeY}$ is not satisfied), LFNST may be applied and the LFNST index is not transmitted.

[0325] In addition, the LFNST index may be signaled only when the last non-zero coefficient position is not the DC position (which is a position at the top-left of the block).

[0326] In the case of a luma block of the dual-tree type, when the last non-zero coefficient position is not the DC position, the LFNST index is transmitted. In the case of a chroma block of the dual-tree type, when any one of the last non-zero coefficient position for Cb and the last non-zero coefficient position for Cr is not the DC position, a corresponding LFNST index is transmitted. In the case of a single-tree type, the LFNST index may be transmitted when the last non-zero coefficient position for any one of a luma component, a Cb component, and a Cr component is not the DC position.

[0327] Meanwhile, when ISP is applied to the coding unit, the LFNST index may be signaled without checking the last non-zero coefficient position (IntraSubPartitionsSplitType != ISP_NO_SPLIT || lfnstDcOnly == 0). That is, even when the last non-zero coefficient position for all partition blocks is located at the DC position, LFNST index signaling may be allowed. The DC position indicates a position at the top-left of a corresponding block.

[0328] Lastly, when it is found that the transform coefficient exists at a position other than a position where the LFNST transform coefficient is allowed to exist, LFNST index signaling may be omitted (lfnstZeroOutSigCoeffFlag == 1).

[0329] In a case where ISP is applied to a coding unit, when it is confirmed that a transform coefficient exists at a position other than a position where an LFNST transform coefficient is supposed to exist even for one partition block among all partition blocks, LFNST index signaling may be omitted.

[0330] The following drawings are provided to describe specific examples of the present disclosure. Since the specific designations of devices or the designations of specific signals/messages/fields illustrated in the drawings are provided for illustration, technical features of the present disclosure are not limited to specific designations used in the following drawings.

[0331] FIG. 21 is a flowchart illustrating an operation of a video decoding apparatus according to an embodiment of this document.

[0332] Each operation disclosed in FIG. 21 is based on some of the above descriptions of FIGS. 4 to 20. Therefore, detailed descriptions which are the same as the above descriptions of FIGS. 3 to 20 will be omitted or simplified.

[0333] The decoding apparatus 300 according to an embodiment may receive residual information from a bitstream (S2110).

[0334] More specifically, the decoding apparatus 300 may decode information on quantized transform coefficients for the target block from the bitstream and may derive the quantized transform coefficients for the current block based on the information on the quantized transform coefficients for the current block. The information on the quantized transform coefficients for the target block may be included in a sequence parameter set (SPS) or a slice header and may include at least one of information on whether a reduced transform (RST) is applied, information on the simplification factor, information on a minimum transform size in which the reduced transform is applied, information on a maximum transform size in which the reduced transform is applied, a reduced inverse transform size, and information on a transform index indicating any one of transform kernel matrices included in a transform set.

[0335] In addition, the decoding apparatus may further receive information on an intra prediction mode for the current block and information on whether the ISP is applied to the current block. The decoding apparatus may derive whether the current block is divided into a predetermined number of sub-partition blocks, by receiving and parsing flag information indicating whether to apply ISP coding or the ISP mode. Here, the current block may be a coding block. In addition, the decoding apparatus may derive the size and number of divided sub-partition blocks through flag information indicating in which direction the current block is to be divided.

[0336] For example, when the size (width \times height) of the current block is 8x4 as shown in FIG. 16, the current block may be divided into two sub-blocks in a vertical direction, and when the size (width \times height) of the current block is 4x8, the current block may be divided into two sub-blocks in a horizontal direction. Alternatively, as shown in FIG. 17, when the size (width \times height) of the current block is greater than 4x8 or 8x4, that is, when the size of the current block is 1) $4 \times N$ or $N \times 4$ ($N \geq 16$) or 2) $M \times N$ ($M \geq 8$, $N \geq 8$), the current block may be divided into 4 sub-blocks in the horizontal or vertical direction.

[0337] The same intra prediction mode may be applied to the sub-partition blocks divided from the current block, and the decoding apparatus may derive prediction samples for the respective sub-partition blocks. That is, the decoding apparatus sequentially performs intra prediction, for example, horizontally or vertically, from left to right or from top to bottom, according to a form in which the sub-partition blocks are divided. For a leftmost or uppermost sub-block, a reconstructed pixel of the coding block already coded is referred to as in a conventional intra prediction method. In addition, when each side of a subsequent internal sub-partition block is not adjacent to a previous sub-partition block, a reconstructed pixel of a previously coded adjacent coding block is referred to as in a conventional intra prediction method in order to derive reference pixels adjacent to a corresponding side.

[0338] The decoding apparatus 300 may derive transform coefficients by dequantizing residual information on the current block, that is, quantized transform coefficients (S2120).

[0339] The derived transform coefficients may be arranged according to a reverse diagonal scanning order in units of 4×4 blocks, and transform coefficients in a 4×4 block may also be arranged according to the reverse diagonal scanning order. That is, dequantized transform coefficients may be arranged according to a reverse scanning order that is applied in a video codec such as in VVC or HEVC.

[0340] A transform coefficient derived based on the residual information may be a dequantized transform coefficient as described above or may be a quantized transform coefficient. That is, the transform coefficient may be data able to be check whether it is non-zero data in the current block regardless of quantization.

[0341] In order to derive modified transform coefficients by applying LFNST, the decoding apparatus may derive a first variable indicating whether the transform coefficient, that is, a significant coefficient, exists in a region except for the DC position of the current block (S2130).

[0342] The first variable may be a variable `LfnstDcOnly` that can be derived in a residual coding process. When the index of a subblock including the last significant coefficient in the current block is 0 and the position of the last significant coefficient in the subblock is greater than 0, the first variable may be derived as 0, and when the first variable is 0, the LFNST index may be parsed. A sub-block refers to a unit block used as a coding unit in residual coding, and when the current block is greater than or equal to 4×4 , a corresponding unit block is a 4×4 block and may be referred to as a coefficient group (CG). A subblock index of 0 indicates the top-left 4×4 subblock when the current block is greater than or equal to 4×4 .

[0343] The first variable may be initially set to 1, and may be maintained as 1 or may be changed to 0 depending on whether a significant coefficient exists in a region except for the DC position.

[0344] The variable `LfnstDcOnly` indicates whether a non-zero coefficient exists at a position other than the DC component with respect to at least one transform block in one coding unit, and when a non-zero coefficient exists at a position other than the DC component with respect to at least one transform block in one coding unit, the variable `LfnstDcOnly` may be 0, and when a non-zero coefficient does not exist at a position other than the DC component with respect to all transform blocks in one coding unit, the variable `LfnstDcOnly` may be 1.

[0345] The decoding apparatus may, based on the derivation result, parse the LFNST index and, based on the current block being divided into a plurality of sub-partition blocks, parse the LFNST index without deriving the first variable (S2140).

[0346] According to an example, the decoding apparatus may parse the LFNST index when the current block is not divided into a plurality of sub-partition blocks and the first variable indicates that a transform coefficient exists in a region except for the DC position, and when the first block is divided into a plurality of sub-partition blocks, the decoding apparatus may parse the LFNST index without checking the first variable or with ignoring the first variable value.

[0347] That is, when ISP is applied to the current block, LFNST index signaling may be allowed even if the last non-zero coefficient for every sub-partition block is located at a DC position.

[0348] In addition, according to an example, the decoding apparatus may further determine whether any transform coefficient exists in a second region other than the first region positioned at the top-left of the current block, and when any transform coefficient does not exist in the second region, the LFNST index may be parsed.

[0349] By deriving a second variable indicating whether a significant coefficient exists in the second region other than the first region positioned at the top-left of the current block, it is possible to check whether zero-out has been performed on the second region.

[0350] The second variable may be a variable *LfnstZeroOutSigCoeffFlag* indicating that zero-out is performed when LFNST is applied. The second variable may be initially set to 1, and when a significant coefficient exists in the second region, the second variable may be changed to 0.

[0351] When the index of a sub-block in which the last non-zero coefficient exists is greater than 0 and the width and the height of a transform block are both equal to or greater than 4, or when the last position of a non-zero coefficient in a sub-block in which the last non-zero coefficient exists is greater than 7 and the size of a transform block is 4x4 or 8x8, the variable *LfnstZeroOutSigCoeffFlag* may be derived as 0.

[0352] That is, when a non-zero coefficient is derived in a region other than the top-left region in which an LFNST transform coefficient can exist or when a non-zero coefficient exists outside the 8th position in the scanning order with respect to a 4x4 block and a 8x8 block, the variable *LfnstZeroOutSigCoeffFlag* is set to 0.

[0353] According to an example, in a case where ISP is applied to a coding unit, when it is found that a transform coefficient exists at a position other than a position where the LFNST transform coefficient can exist with respect even to one sub-partition block among all sub-partition blocks, the LFNST index signaling may be omitted. That is, when zero-out is not performed on one sub-partition block and a significant coefficient exists in the second region, the LFNST index is not signaled.

[0354] Meanwhile, the first region may be derived based on the size of the current block.

[0355] For example, when the size of the current block is 4x4 or 8x8, the first region may be a region from the top-left of the current block to the 8th sample position in a scan direction. When the current block is divided and the size of a sub-partition block is 4x4 or 8x8, the first region may be a region from the top-left to the 8th sample position of the sub-partition blocks in the scan direction.

[0356] When the size of the current block is 4x4 or 8x8, 8 data are output through the forward LFNST, and thus, 8 transform coefficients received by the decoding apparatus may be arranged from the top-left of the current block to the 8th sample position in a scan direction, as shown in (a) of FIG. 13 and (a) of FIG. 14.

[0357] In addition, when the size of the current block is not 4x4 or 8x8, the first region may be a 4x4 region at the top-left of the current block. When the size of the current block is not 4x4 or 8x8, 16 data are output through the forward LFNST, and thus, 16 transform coefficients received by the decoding apparatus may be arranged in the top-left 4x4 region in the current block, as shown in (b) to (d) of FIG. 13 and (b) of FIG. 14.

[0358] Meanwhile, transform coefficients which can be arranged in the first region may be arranged along a diagonal scan direction, as shown in FIG. 8.

[0359] As described above, in a case where the current block is divided into sub-partition blocks, the decoding apparatus may parse the LFNST index when no transform coefficients exist in all of the respective second regions for the plurality of sub-partition blocks. When a transform coefficient exists in the second region of any one sub-partition block, the LFNST index is not parsed.

[0360] As described above, LFNST may be applied to a sub-partition block whose width and height are greater than or equal to 4, and the LFNST index for the current block which is a coding block may be applied to a plurality of sub-partition blocks.

[0361] Meanwhile, since LFNST-reflected zero-out (including all zero-outs that may be accompanied by application of LFNST) is also applied to a sub-partition block, the first region is equally applied to the sub-partition block. That is, when a divided sub-partition block is a 4x4 block or an 8x8 block, LFNST is applied up to 8th transform coefficients in a scan direction from a top-left position of the sub-partition block, and when the sub-partition block is not a 4x4 block or an 8x8 block, LFNST may be applied to transform coefficients in a top-left 4x4 region of the sub-partition block.

[0362] Then, the decoding apparatus may derive modified transform coefficients from the transform coefficients based on the LFNST index and the LFNST matrix for LFNST (S2150).

[0363] The decoding apparatus may determine an LFNST set including the LFNST matrix based on the intra prediction

mode derived from intra prediction mode information, and select any one of the plurality of LFNST matrices based on the LFNST set and the LFNST index.

[0364] In this case, the same LFNST set and the same LFNST index may be applied to the sub-partition transform block divided from the current block. That is, because the same intra prediction mode is applied to the sub-partition transform blocks, the LFNST set determined based on the intra prediction mode may be equally applied to all sub-partition transform blocks. Further, because the LFNST index is signaled at a coding unit level, the same LFNST matrix may be applied to the sub-partition transform block divided from the current block.

[0365] As described above, the transform set may be determined according to the intra prediction mode of the transform block to be transformed, and inverse LFNST may be performed based on any one of transform kernel matrices, that is, LFNST matrices, included in the transform set indicated by the LFNST index. A matrix applied to the inverse LFNST may be referred to as an inverse LFNST matrix or an LFNST matrix, and such a matrix may have any name as long as it has a transpose relationship with the matrix used for the forward LFNST.

[0366] In one example, the inverse LFNST matrix may be a non-square matrix in which the number of columns is smaller than the number of rows.

[0367] A predetermined number of transform coefficients, which are output data of LFNST, may be derived based on the size of the current block or a sub-partition transform block. For example, when the height and width of the current block or the sub-partition transform block are 8 or more, 48 transform coefficients may be derived, as illustrated in the left of FIG. 7, and when the width and height of the sub-partition transform block are not 8 or more, that is, when the width or height of the sub-partition transform block is 4 or more and less than 8, 16 transform coefficients may be derived, as illustrated in the right side of FIG. 7.

[0368] As illustrated in FIG. 7, 48 transform coefficients may be arranged in the top-left, top-right, and lower left 4x4 regions of the top-left 8x8 region of the sub-partition transform block, and 16 transform coefficients may be arranged in the top-left 4x4 region of the sub-partition transform block.

[0369] The 48 transform coefficients and 16 transform coefficients may be arranged in a vertical or horizontal direction according to an intra prediction mode of the sub-partition transform block. For example, when the intra prediction mode is a horizontal direction (modes 2 to 34 in FIG. 9) based on a diagonal direction (mode 34 in FIG. 9), the transform coefficients may be arranged in a horizontal direction, that is, in row-first direction order, as illustrated in (a) of FIG. 7, and when the intra prediction mode is a vertical direction (modes 35 to 66 in FIG. 9) based on a diagonal direction, the transform coefficients may be arranged in a horizontal direction, that is, in column-first direction order, as illustrated in (b) of FIG. 7.

[0370] The decoding apparatus may derive residual samples for the current block based on a primary inverse transform of the modified transform coefficient (S2160).

[0371] In this case, a simplified inverse transform may be applied to an inverse primary transform, or a conventional separable transform may be used. Alternatively, MTS may be used as the inverse primary transform.

[0372] Subsequently, the decoding apparatus 300 may generate reconstructed samples based on residual samples for the current block and prediction samples for the current block.

[0373] The following drawings are provided to describe specific examples of the present disclosure. Since the specific designations of devices or the designations of specific signals/messages/fields illustrated in the drawings are provided for illustration, technical features of the present disclosure are not limited to specific designations used in the following drawings.

[0374] FIG. 22 is a flowchart illustrating an operation of a video encoding apparatus according to an embodiment of this document.

[0375] Each step disclosed in FIG. 22 is based on some of the contents described above in FIGS. 4 to 20. Accordingly, detailed descriptions overlapping with those described above in FIGS. 2 and 4 to 20 will be omitted or simplified.

[0376] The encoding apparatus 200 according to an embodiment may derive a prediction sample for the current block based on the intra prediction mode applied to the current block (S2210).

[0377] The encoding apparatus may perform prediction for each sub-partition transformation block when ISP is applied to the current block.

[0378] The encoding apparatus may determine whether to apply ISP coding or an ISP mode to the current block, that is, the coding block, determine a direction in which the current block will be divided according to the determination result, and derive the size and number of divided sub-blocks.

[0379] For example, when the size (width \times height) of the current block is 8×4 , as illustrated in FIG. 16, the current block may be vertically divided and divided into two sub-blocks, and when the size (width \times height) of the current block is 4×8 , the current block may be horizontally divided and divided into two sub-blocks. Alternatively, as illustrated in FIG. 17, when the size (width \times height) of the current block is greater than 4×8 or 8×4 , that is, when the size of the current block is 1) $4 \times N$ or $N \times 4$ ($N \geq 16$) or 2) $M \times N$ ($M \geq 8, N \geq 8$), the current block may be divided into 4 sub-blocks in a horizontal or vertical direction.

[0380] The same intra prediction mode may be applied to the sub-partition transform block divided from the current

block, and the encoding apparatus may derive a prediction sample for each sub-partition transform block. That is, the encoding apparatus sequentially performs intra prediction, for example, horizontally or vertically, from left to right, or from top to bottom according to a division form of the sub-partition transform blocks. For the leftmost or uppermost subblock, a reconstructed pixel of an already coded coding block is referred to, as in a conventional intra prediction method. Further, for each side of the subsequent internal sub-partition transform block, when it is not adjacent to the previous sub-partition transform block, in order to derive reference pixels adjacent to the corresponding side, a reconstructed pixel of an already coded adjacent coding block is referred to, as in a conventional intra prediction method.

[0381] The encoding apparatus 200 may derive residual samples of the current block based on prediction samples (S2220).

[0382] Further, the encoding apparatus 200 may derive transform coefficients for the current block based on a primary transform of the residual sample (S2230).

[0383] The primary transform may be performed through a plurality of transform kernels, and in this case, a transform kernel may be selected based on the intra prediction mode.

[0384] The encoding apparatus 200 may determine whether to perform a secondary transform or a non-separable transform, specifically LFNST, on transform coefficients for the current block, and may apply LFNST to the transform coefficients to derive modified transform coefficients.

[0385] Unlike the primary transform that separates and transforms target coefficients in a vertical or horizontal direction, LFNST is a non-separable transform that applies the transform without separating the coefficients in a specific direction. The non-separable transform may be a low-frequency non-separable transform that applies the transform only to a low-frequency region rather than the entire target block to be transformed.

[0386] According to an example, the encoding apparatus may determine whether LFNST is applicable to a height and a width of the current block based on a tree type and a color format of the current block.

[0387] According to an example, in a case where the tree type of the current block is dual-tree chroma, when the height and width corresponding to a chroma component block of the current block are greater than or equal to 4, the encoding apparatus may determine that LFNST is applicable.

[0388] In addition, according to an example, in a case where the tree type of the current block is single-tree or dual-tree luma, when the height and width corresponding to a luma component block of the current block are greater than or equal to 4, the encoding apparatus may determine that LFNST is applicable.

[0389] Meanwhile, when ISP is applied to the current block, that is, when the current block is divided into sub-partition transformation blocks, the encoding apparatus may determine whether LFNST is applicable to the height and width of a divided sub-partition block. In this case, when the height and width of the sub-partition block are greater than or equal to 4, the encoding apparatus may determine that LFNST is applicable.

[0390] For example, when the tree type of the current block is dual-tree chroma, ISP may not be applied and in this case, when the height and width corresponding to a chroma component block of the current block are greater than or equal to 4, the encoding apparatus may determine that LFNST is applicable.

[0391] On the other hand, in a case where the tree type of the current block is not dual-tree chroma but dual-tree or single-tree luma, when the height and width of a sub-partition block for a luma component block of the current block or the height and width of the current block are greater than or equal to 4, the encoding apparatus may determine, depending on whether ISP is applied to the current block, that LFNST is applicable.

[0392] In addition, according to an example, when the current block is a coding unit and the width and height of the coding unit are smaller than or equal to a maximum luma transformable size, the encoding apparatus may determine that LFNST is applicable.

[0393] When it is determined to perform LFNST, the encoding apparatus 200 may derive a modified transform coefficient for the current block or the sub-partition transform block based on an LFNST set mapped to the intra prediction mode and an LFNST matrix included in the LFNST set (S2240).

[0394] The encoding apparatus 200 may determine the LFNST set based on a mapping relationship according to the intra prediction mode applied to the current block, and perform an LFNST, that is, a non-separable transform based on one of two LFNST matrices included in the LFNST set.

[0395] In this case, the same LFNST set and the same LFNST index may be applied to the sub-partition transform block divided from the current block. That is, because the same intra prediction mode is applied to the sub-partition transform blocks, the LFNST set determined based on the intra prediction mode may also be equally applied to all sub-partition transform blocks. Further, because the LFNST index is encoded in units of a coding unit, the same LFNST matrix may be applied to the sub-partition transform block divided from the current block.

[0396] As described above, a transform set may be determined according to an intra prediction mode of a transform block to be transformed. A matrix applied to LFNST has a transpose relationship with a matrix used for an inverse LFNST.

[0397] In one example, the LFNST matrix may be a non-square matrix in which the number of rows is smaller than that of columns.

[0398] A region in which transform coefficients used as input data of LFNST are located may be derived based on the

size of a sub-partition transform block. For example, when the height and width of the sub-partition transform block are 8 or more, the region is top-left, top-right, and bottom-left 4x4 regions of the top-left 8x8 region of the sub-partition transform block, as illustrated in the left of FIG. 7, and when the height and width of the sub-partition transform block are not equal to or greater than 8, the region may be the top-left 4x4 region of the current block, as illustrated in the right side of FIG. 7.

[0399] The transform coefficients in the region may be read in a vertical or horizontal direction according to an intra prediction mode of a sub-partition transform block to construct a one-dimensional vector for a multiplication operation with the LFNST matrix.

[0400] 48 modified transform coefficients or 16 modified transform coefficients may be read in a vertical or horizontal direction according to the intra prediction mode of the sub-partition transform block and arranged in one dimension. For example, when the intra prediction mode is a horizontal direction (modes 2 to 34 in FIG. 9) based on a diagonal direction (mode 34 in FIG. 9), the transform coefficients may be arranged in a horizontal direction, that is, in row-first direction order, as illustrated in (a) of FIG. 7, and when the intra prediction mode is a vertical direction (modes 35 to 66 in FIG. 9) based on a diagonal direction, the transform coefficients may be arranged in a horizontal direction, that is, in column-first direction order, as illustrated in (b) of FIG. 7.

[0401] In one embodiment, the encoding apparatus may include steps of determining whether the encoding apparatus is in a condition to apply LFNST, generating and encoding an LFNST index based on the determination, selecting a transform kernel matrix, and applying the LFNST to the residual samples based on the selected transform kernel matrix and/or a simplification factor when the encoding apparatus is in a condition to apply LFNST. In this case, a size of the simplification transform kernel matrix may be determined based on a simplification factor.

[0402] Meanwhile, according to an example, the encoding apparatus may zero out the second region of the current block in which modified transform coefficients do not exist.

[0403] As shown in FIGS. 13 and 14, all remaining regions of the current block in which modified transform coefficient do not exist may be processed as 0. Due to this zero-out, the amount of calculation required to perform the entire transform process is reduced, and the amount of computation required for the entire transform process is reduced, thereby reducing power consumption required to perform the transform. In addition, the image coding efficiency may increase by reducing the latency involved in the transform process.

[0404] According to an example, the encoding apparatus may, based on the transform coefficients existing in a region except for the DC position of the current block, configure image information so that the LFNST index indicating an LFNST matrix is signaled, and the encoding apparatus may, based on the current block being divided into a plurality of sub-partition blocks, configure image information so that the LFNST index is signaled regardless of whether a transform coefficient exists in a region except for the DC position (S2250).

[0405] The encoding apparatus may configure the image information so that the image information shown in Table 10 is parsed by the decoding apparatus.

[0406] That is, when the current block is not divided into a plurality of sub-partition blocks and the transform coefficients exist in a region except for the DC position of the current block, the encoding apparatus may configure image information so that the LFNST index is parsed, and when the current block is divided into a plurality of sub-partition blocks, the encoding apparatus may configure image information so that the LFNST index is parsed without checking whether a transform coefficient exists in a region except for the DC position.

[0407] That is, when the ISP is applied to the current block, the encoding apparatus may configure image information so that the LFNST index is signaled even if the last non-zero coefficients for all sub-partition blocks are located at the DC position.

[0408] According to an example, when the index of a sub-block including the last significant coefficient in the current block (or a sub-partition block) is 0 and the position of the last significant coefficient in the subblock is greater than 0, the encoding apparatus may determine that the significant coefficient exists in a region except for the DC position and may configure image information so that the LFNST index is signaled. In this present disclosure, the first position in the scan order may be 0.

[0409] In addition, according to an example, when the index of a sub-block including the last significant coefficient in the current block (or a sub-partition block) is greater than 0 and the width and height of the current block are greater than or equal to 4, the encoding apparatus may determine that LFNST is certainly not applied and may configure image information so that an LFSNT index is not signaled.

[0410] In addition, according to an example, when the size of the current block (or a sub-partition block) is 4x4 or 8x8 and when the position of the last significant coefficient is greater than 7 in a case where the start of the position in the scan order is 0, the encoding apparatus may determine that the LFNST is certainly not applied and may configure image information so that the LFNST index is not signaled.

[0411] That is, after the variable `LfnstDcOnly` and the variable `LfnstZeroOutSigCoeffFlag` are derived in the decoding apparatus, the encoding apparatus may configure image information so that the LFNST index is parsed according to the derived variable values.

[0412] The encoding apparatus may derive quantized transform coefficients by performing quantization based on the modified transform coefficients for the current block, and may encode information on the quantized transform coefficients and, if LFNST is applicable, the LFNST index (S2260).

5 **[0413]** That is, the encoding apparatus may generate residual information including information on quantized transform coefficients. The residual information may include the above-described transform related information/syntax element. The encoding apparatus may encode image/video information including residual information and output the encoded image/video information in the form of a bitstream.

[0414] More specifically, the encoding apparatus 200 may generate information about the quantized transform coefficients and encode the information about the generated quantized transform coefficients.

10 **[0415]** The syntax element of the LFNST index according to the present embodiment may indicate whether (inverse) LFNST is applied and any one of the LFNST matrices included in the LFNST set, and when the LFNST set includes two transform kernel matrices, there may be three values of the syntax element of the LFNST index.

[0416] According to an embodiment, when a division tree structure for the current block is a dual tree type, an LFNST index may be encoded for each of a luma block and a chroma block.

15 **[0417]** According to an embodiment, the syntax element value for the transform index may be derived as 0 indicating a case in which (inverse) LFNST is not applied to the current block, 1 indicating a first LFNST matrix among LFNST matrices, and 2 indicating a second LFNST matrix among LFNST matrices.

[0418] In the present disclosure, at least one of quantization/dequantization and/or transform/inverse transform may be omitted. When quantization/dequantization is omitted, a quantized transform coefficient may be referred to as a transform coefficient. When transform/inverse transform is omitted, the transform coefficient may be referred to as a coefficient or a residual coefficient, or may still be referred to as a transform coefficient for consistency of expression.

20 **[0419]** In addition, in the present disclosure, a quantized transform coefficient and a transform coefficient may be referred to as a transform coefficient and a scaled transform coefficient, respectively. In this case, residual information may include information on a transform coefficient(s), and the information on the transform coefficient(s) may be signaled through a residual coding syntax. Transform coefficients may be derived based on the residual information (or information on the transform coefficient(s)), and scaled transform coefficients may be derived through inverse transform (scaling) of the transform coefficients. Residual samples may be derived based on the inverse transform (transform) of the scaled transform coefficients. These details may also be applied/expressed in other parts of the present disclosure.

25 **[0420]** In the above-described embodiments, the methods are explained on the basis of flowcharts by means of a series of steps or blocks, but the present disclosure is not limited to the order of steps, and a certain step may be performed in order or step different from that described above, or concurrently with another step. Further, it may be understood by a person having ordinary skill in the art that the steps shown in a flowchart are not exclusive, and that another step may be incorporated or one or more steps of the flowchart may be removed without affecting the scope of the present disclosure.

30 **[0421]** The above-described methods according to the present disclosure may be implemented as a software form, and an encoding apparatus and/or decoding apparatus according to the disclosure may be included in a device for image processing, such as, a TV, a computer, a smartphone, a set-top box, a display device or the like.

35 **[0422]** When embodiments in the present disclosure are embodied by software, the above-described methods may be embodied as modules (processes, functions or the like) to perform the above-described functions. The modules may be stored in a memory and may be executed by a processor. The memory may be inside or outside the processor and may be connected to the processor in various well-known manners. The processor may include an application-specific integrated circuit (ASIC), other chipset, logic circuit, and/or a data processing device. The memory may include a read-only memory (ROM), a random access memory (RAM), a flash memory, a memory card, a storage medium, and/or other storage device. That is, embodiments described in the present disclosure may be embodied and performed on a processor, a microprocessor, a controller or a chip. For example, function units shown in each drawing may be embodied and performed on a computer, a processor, a microprocessor, a controller or a chip.

40 **[0423]** Further, the decoding apparatus and the encoding apparatus to which the present disclosure is applied, may be included in a multimedia broadcasting transceiver, a mobile communication terminal, a home cinema video device, a digital cinema video device, a surveillance camera, a video chat device, a real time communication device such as video communication, a mobile streaming device, a storage medium, a camcorder, a video on demand (VoD) service providing device, an over the top (OTT) video device, an Internet streaming service providing device, a three-dimensional (3D) video device, a video telephony video device, and a medical video device, and may be used to process a video signal or a data signal. For example, the over the top (OTT) video device may include a game console, a Blu-ray player, an Internet access TV, a Home theater system, a smartphone, a Tablet PC, a digital video recorder (DVR) and the like.

45 **[0424]** In addition, the processing method to which the present disclosure is applied, may be produced in the form of a program executed by a computer, and be stored in a computer-readable recording medium. Multimedia data having a data structure according to the present disclosure may also be stored in a computer-readable recording medium. The computer-readable recording medium includes all kinds of storage devices and distributed storage devices in which

computer-readable data are stored. The computer-readable recording medium may include, for example, a Blu-ray Disc (BD), a universal serial bus (USB), a ROM, a PROM, an EPROM, an EEPROM, a RAM, a CD-ROM, a magnetic tape, a floppy disk, and an optical data storage device. Further, the computer-readable recording medium includes media embodied in the form of a carrier wave (for example, transmission over the Internet). In addition, a bitstream generated by the encoding method may be stored in a computer-readable recording medium or transmitted through a wired or wireless communication network. Additionally, the embodiments of the present disclosure may be embodied as a computer program product by program codes, and the program codes may be executed on a computer by the embodiments of the present disclosure. The program codes may be stored on a computer-readable carrier.

[0425] FIG. 23 illustrates the structure of a content streaming system to which the present disclosure is applied.

[0426] Further, the contents streaming system to which the present disclosure is applied may largely include an encoding server, a streaming server, a web server, a media storage, a user equipment, and a multimedia input device.

[0427] The encoding server functions to compress to digital data the contents input from the multimedia input devices, such as the smart phone, the camera, the camcorder and the like, to generate a bitstream, and to transmit it to the streaming server. As another example, in a case where the multimedia input device, such as, the smart phone, the camera, the camcorder or the like, directly generates a bitstream, the encoding server may be omitted. The bitstream may be generated by an encoding method or a bitstream generation method to which the present disclosure is applied. And the streaming server may store the bitstream temporarily during a process to transmit or receive the bitstream.

[0428] The streaming server transmits multimedia data to the user equipment on the basis of a user's request through the web server, which functions as an instrument that informs a user of what service there is. When the user requests a service which the user wants, the web server transfers the request to the streaming server, and the streaming server transmits multimedia data to the user. In this regard, the contents streaming system may include a separate control server, and in this case, the control server functions to control commands/responses between respective equipments in the content streaming system.

[0429] The streaming server may receive contents from the media storage and/or the encoding server. For example, in a case the contents are received from the encoding server, the contents may be received in real time. In this case, the streaming server may store the bitstream for a predetermined period of time to provide the streaming service smoothly.

[0430] For example, the user equipment may include a mobile phone, a smart phone, a laptop computer, a digital broadcasting terminal, a personal digital assistant (PDA), a portable multimedia player (PMP), a navigation, a slate PC, a tablet PC, an ultrabook, a wearable device (e.g., a watch-type terminal (smart watch), a glass-type terminal (smart glass), a head mounted display (HMD)), a digital TV, a desktop computer, a digital signage or the like. Each of servers in the contents streaming system may be operated as a distributed server, and in this case, data received by each server may be processed in distributed manner.

[0431] Claims disclosed herein can be combined in a various way. For example, technical features of method claims of the present disclosure can be combined to be implemented or performed in an apparatus, and technical features of apparatus claims can be combined to be implemented or performed in a method. Further, technical features of method claims and apparatus claims can be combined to be implemented or performed in an apparatus, and technical features of method claims and apparatus claims can be combined to be implemented or performed in a method.

[0432] Also provided are the following illustrative, non-exhaustive examples of the subject-matter encompassed herein, which relate to:

[0433] An image decoding method performed by a decoding apparatus, the method comprising:

- receiving residual information from a bitstream;
- deriving a transform coefficient for a current block based on the residual information;
- deriving modified transform coefficients by applying LFNST to the transform coefficients;
- deriving residual samples for the current block based on an inverse primary transform on the modified transform coefficients; and
- generating a reconstructed picture based on the residual samples, wherein deriving the modified transform coefficient comprises:

- deriving a first variable indicating whether the transform coefficient exists in a region except for a DC position of the current block;
- parsing an LFNST index based on a result of the deriving; and
- deriving the modified transform coefficient based on the LFNST index and an LFNST matrix, wherein, based on the current block being divided into a plurality of sub-partition blocks, the LFNST index is parsed without deriving of the first variable.

[0434] The image decoding method described in the immediately preceding paragraph, wherein when the current block is not divided into the plurality of sub-partition blocks and the first variable indicates that the transform coefficient

exists in the region except for the DC position, the LFNST index is parsed.

[0435] The image decoding method described in the first one of the two immediately preceding paragraphs,

wherein deriving the modified transform coefficient further comprises
 5 determining whether the transform coefficient exists in a second region except for a first region at a top-left of the current block,
 wherein when the transform coefficient does not exist in the second region, the LFNST index is parsed.

[0436] The image decoding method described in the immediately preceding paragraph, wherein when the transform coefficient does not exist in all of the second region of each of the plurality of sub-partition blocks, the LFNST index is parsed.

[0437] The image decoding method described in the first one of the four immediately preceding paragraphs,

wherein the current block is a coding block,
 15 wherein when a width and a height of each sub-partition block are each greater than or equal to 4, the LFNST index for the current block is applied to the plurality of sub-partition blocks.

[0438] The image decoding method described in the first one of the three immediately preceding paragraphs, wherein when a divided sub-partition block is a 4x4 block or a 8x8 block, the LFNST is applied from a top-left of the sub-partition block to 8th transform coefficients in a scan direction.

[0439] An image encoding method performed by an encoding apparatus, the method comprising:

deriving transform coefficients for a current block based on a primary transform for residual samples of the current block;
 25 deriving modified transform coefficients from the transform coefficient based on an LFNST matrix for LFNST;
 configuring image information so that an LFNST index indicating the LFNST matrix is signaled based on the transform coefficient existing in a region except for a DC position of the current block; and
 encoding quantized residual information and the LFNST index,
 30 wherein, based on the current block being divided into a plurality of sub-partition blocks, the image information is configured so that the LFNST index is signaled regardless of whether the transform coefficient exists in the region except for the DC position of the current block.

[0440] The image encoding method described in the immediately preceding paragraph, wherein when the current block is not divided into the plurality of sub-partition blocks and the transform coefficients exists in the region except for the DC position of the current block, the LFNST index is encoded.

[0441] The image encoding method described in the first one of the two immediately preceding paragraphs,

wherein the modified transform coefficient is derived based on transform coefficients in a first region at a top-left of the current block and the LFNST matrix,
 40 wherein the image encoding method further comprises zeroing out a second region of the current block in which the modified transform coefficients do not exist,
 wherein when the zeroing out is performed, the image information is configured so that the LFNST index is signaled.

[0442] The image encoding method described in the immediately preceding paragraph wherein when the zeroing out is performed on all of the plurality of sub-partition blocks, the image information is configured so that the LFNST index is signaled.

[0443] The image encoding method described in the first one of the four immediately preceding paragraphs,

wherein the current block is a coding block,
 50 wherein when a width and a height of each sub-partition block are each greater than or equal to 4, the image information is configured so that the LFNST matrix for the current block is applied to the plurality of sub-partition blocks.

[0444] The image encoding method described in the first one of the five immediately preceding paragraphs, wherein when a divided sub-partition block is a 4x4 block or a 8x8 block, eight modified transform coefficients are derived.

[0445] A computer-readable digital storage medium storing instruction information causing
 55 an image decoding method to be performed, wherein the image decoding method comprises: receiving residual information from a bitstream;

deriving a transform coefficient for a current block based on the residual information;
 deriving modified transform coefficients by applying LFNST to the transform coefficients;
 deriving residual samples for the current block based on an inverse primary transform on the modified transform
 coefficients; and
 5 generating a reconstructed picture based on the residual samples,
 wherein deriving the modified transform coefficient comprises:

deriving a first variable indicating whether the transform coefficient exists in a region except for a DC position
 of the current block;
 10 parsing an LFNST index based on a result of the deriving; and
 deriving the modified transform coefficient based on the LFNST index and an LFNST matrix,
 wherein, based on the current block being divided into a plurality of sub-partition blocks, the LFNST index is
 parsed without deriving of the first variable.

15 **Claims**

1. A decoding apparatus for image decoding, the decoding apparatus comprising:

20 a memory; and
 at least one processor connected to the memory, the at least one processor configured to:

obtain residual information from a bitstream;
 derive transform coefficients for a current block from the residual information;
 25 derive modified transform coefficients using a low-frequency non-separable transform, LFNST, matrix ac-
 cording to an LFNST index;
 derive residual samples for the current block by performing an inverse primary transform on the modified
 transform coefficients; and
 generate a reconstructed picture by adding the residual samples and prediction samples of the current block,
 30 wherein for the current block where an Intra Sub Partitions, ISP, mode is not applied, the LFNST index for
 the current block is parsed in response to a non-zero transform coefficient being present in a region other
 than a DC position of any one component block according to a tree type of the current block,
 wherein in response to the LFNST index being not parsed, a value of the LFNST index is derived as 0 and
 the modified transform coefficients are derived as the transform coefficients,
 35 **characterized in that**
 for the current block where the ISP mode is applied, the LFNST index for the current block is parsed without
 considering whether a non-zero transform coefficient is present in the region other than the DC position of
 any one component block according to the tree type of the current block.

40 2. An encoding apparatus for image encoding, the encoding apparatus comprising:

a memory; and
 at least one processor connected to the memory, the at least one processor configured to:

45 derive transform coefficients for a current block by performing a primary transform for residual samples of
 the current block;
 derive modified transform coefficients from the transform coefficients using a low-frequency non-separable
 transform, LFNST, matrix for an LFNST;
 generate an LFNST index related to the LFNST matrix; and
 50 encode image information including residual information related to the modified transform coefficients and
 the LFNST index,
 wherein for the current block where an Intra Sub Partitions, ISP, mode is not applied, the image information
 is configured so that the LFNST index is signaled in response to a non-zero transform coefficient being
 present in a region other than a DC position of any one component block according to a tree type of the
 55 current block,
characterized in that
 for the current block where the ISP mode is applied, the image information is configured so that the LFNST
 index is signaled without considering whether a non-zero transform coefficient is present in the region other

than the DC position of any one component block according to the tree type of the current block.

3. An apparatus for transmitting data for an image, the apparatus comprising:

5 at least one processor configured to obtain a bitstream for the image, wherein the bitstream is generated based on deriving transform coefficients for a current block by performing a primary transform for residual samples of the current block, deriving modified transform coefficients from the transform coefficients using a low-frequency non-separable transform, LFNST, matrix for an LFNST, generating an LFNST index related to the LFNST matrix, encoding image information including residual information related to the modified transform coefficients and the LFNST index; and

10 a transmitter configured to transmit the data comprising the bitstream, wherein for the current block where an Intra Sub Partitions, ISP, mode is not applied, the image information is configured so that the LFNST index is signaled in response to a non-zero transform coefficient being present in a region other than a DC position of any one component block according to a tree type of the current block,

15 **characterized in that** for the current block where the ISP mode is applied, the image information is configured so that the LFNST index is signaled without considering whether a non-zero transform coefficient is present in the region other than the DC position of any one component block according to the tree type of the current block.

20

25

30

35

40

45

50

55

FIG. 1

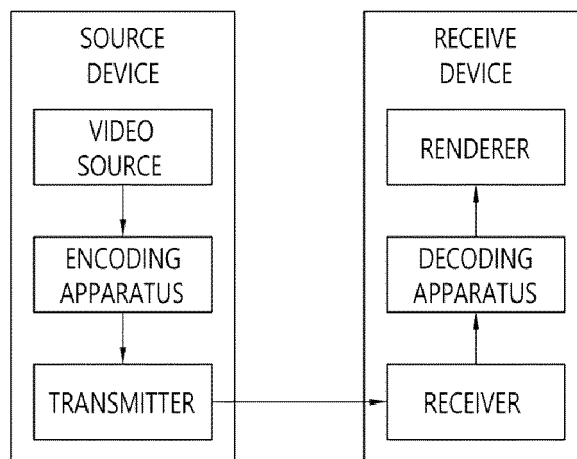

FIG. 2

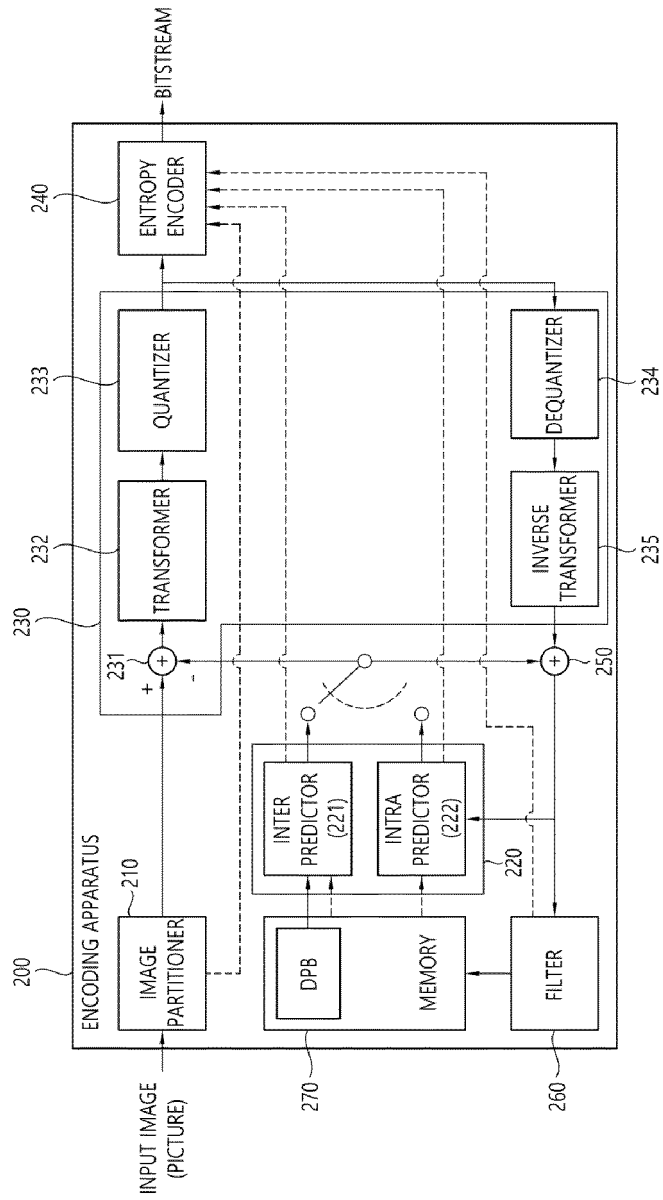

FIG. 3

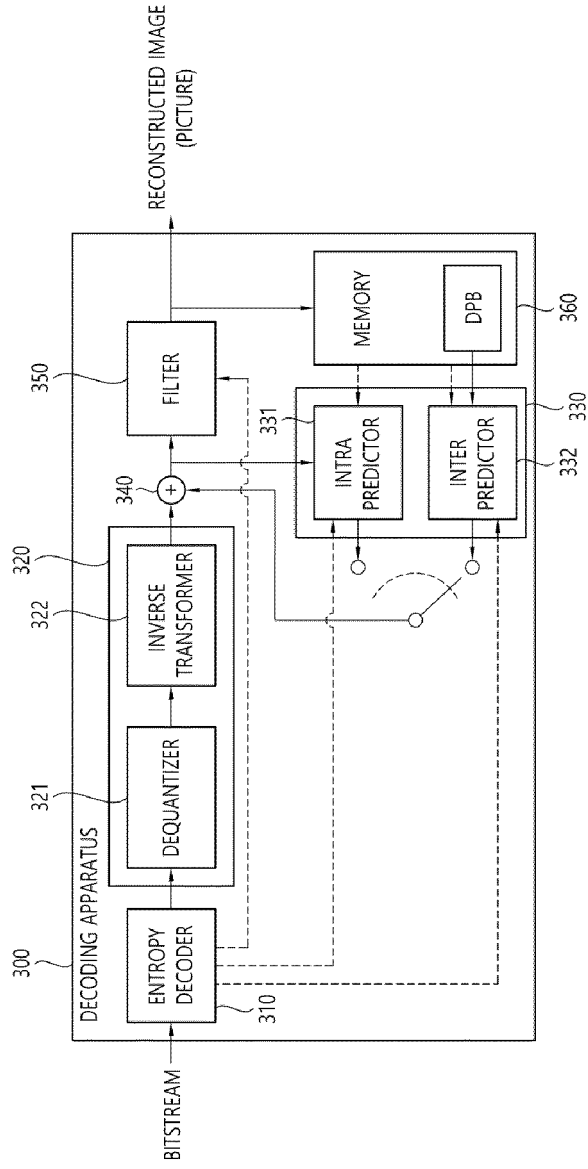

FIG. 4

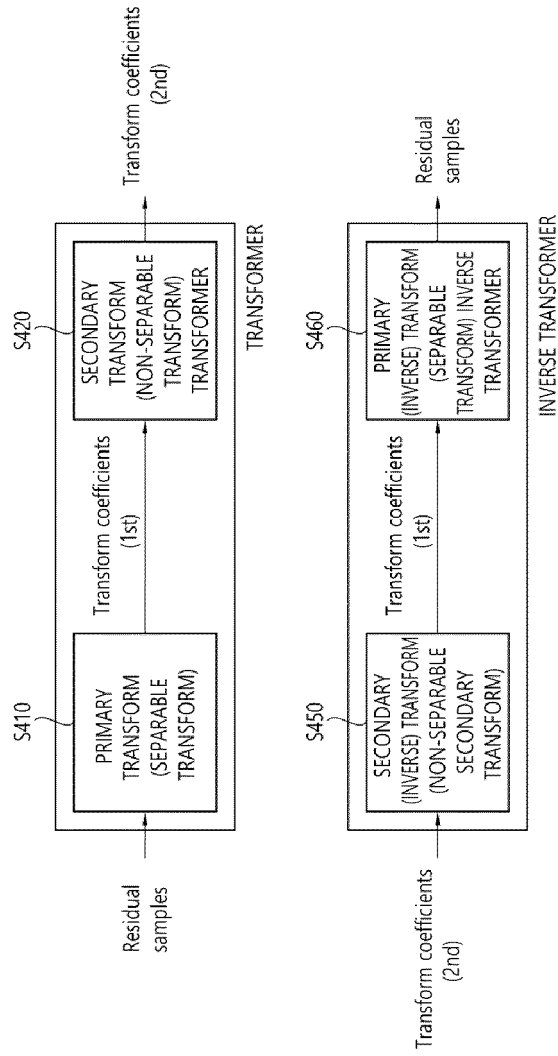

FIG. 5

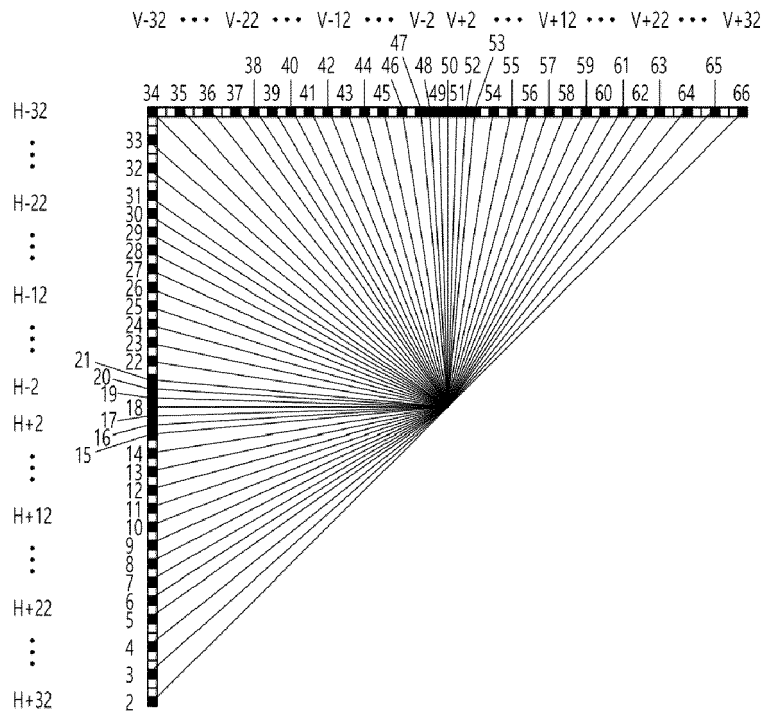

FIG. 6

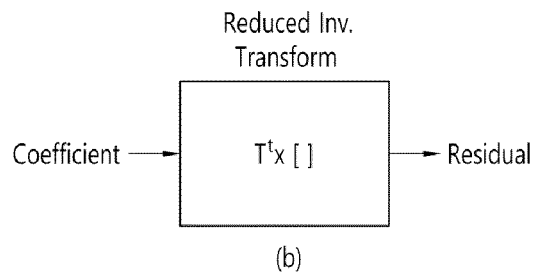
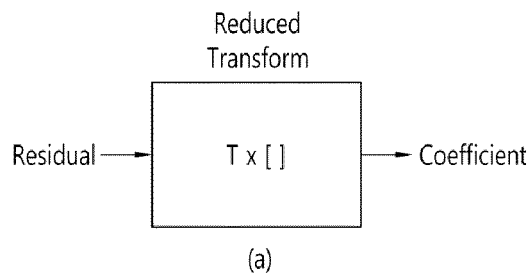

FIG. 7

1	2	3	4	5	6	7	8
9	10	11	12	13	14	15	16
17	18	19	20	21	22	23	24
25	26	27	28	29	30	31	32
33	34	35	36				
37	38	39	40				
41	42	43	44				
45	46	47	48				

1	2	3	4
5	6	7	8
9	10	11	12
13	14	15	16

(a)

1	9	17	25	33	37	41	45
2	10	18	26	34	38	42	46
3	11	19	27	35	39	43	47
4	12	20	28	36	40	44	48
5	13	21	29				
6	14	22	30				
7	15	23	31				
8	16	24	32				

1	5	9	13
2	6	10	14
3	7	11	15
4	8	12	16

(b)

FIG. 8

1	3	6	10
2	5	9	13
4	8	12	15
7	11	14	16

(a)

1	3	6	X
2	5	X	X
4	8	X	X
7	X	X	X

(b)

FIG. 9

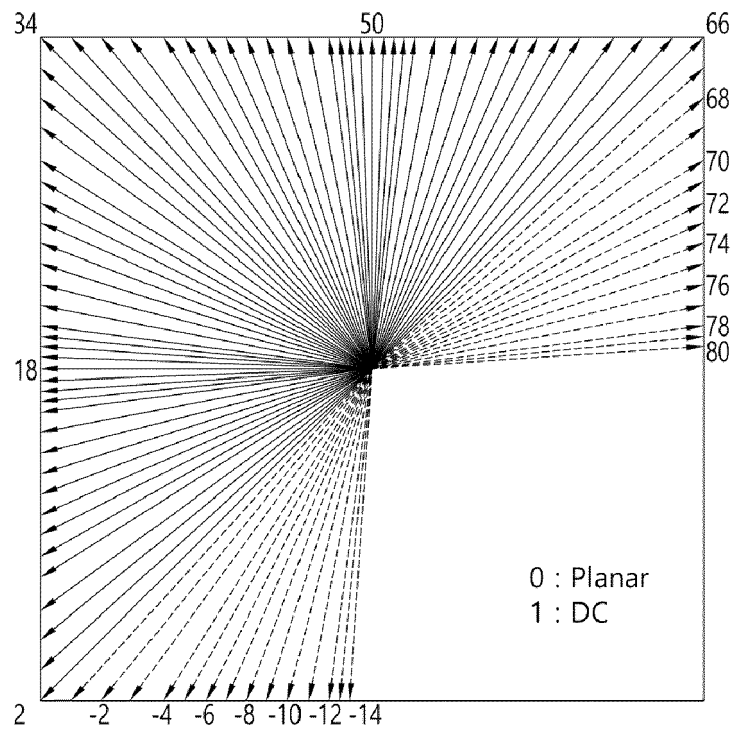
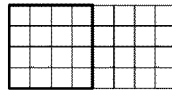

FIG. 10



(a) 4x4



(b) 8x4 / 4x8



(c) 4xN / Nx4, when $N \geq 16$

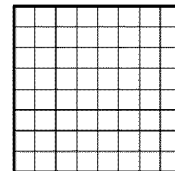

(d) 8x8

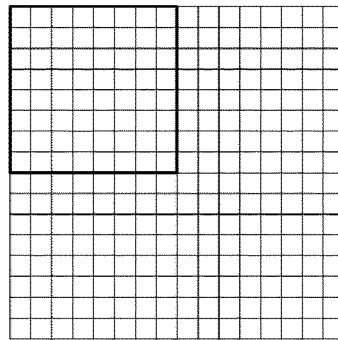

(e) $M \times N (M \geq 8, N \geq 8, M > 8 \text{ or } N > 8)$

FIG. 12

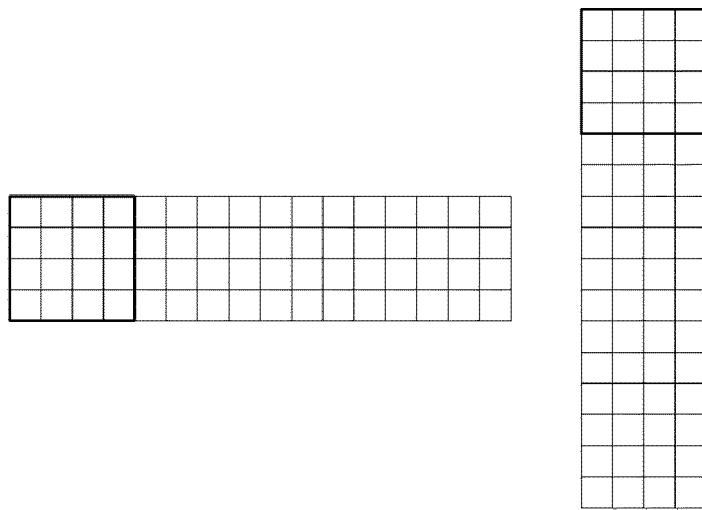

$4 \times N / N \times 4$, when $N \geq 16$

FIG. 13



(a) 4x4

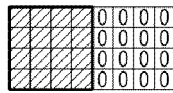

(b) 8x4 / 4x8

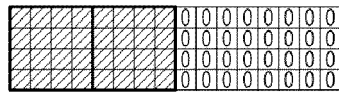

(c) 4xN / Nx4, when $N \geq 16$

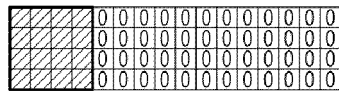
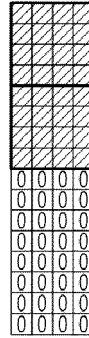

(d) 4xN / Nx4, when $N \geq 16$

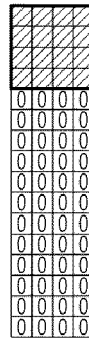

FIG. 16

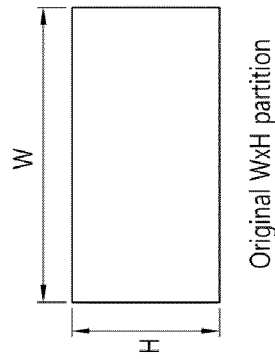
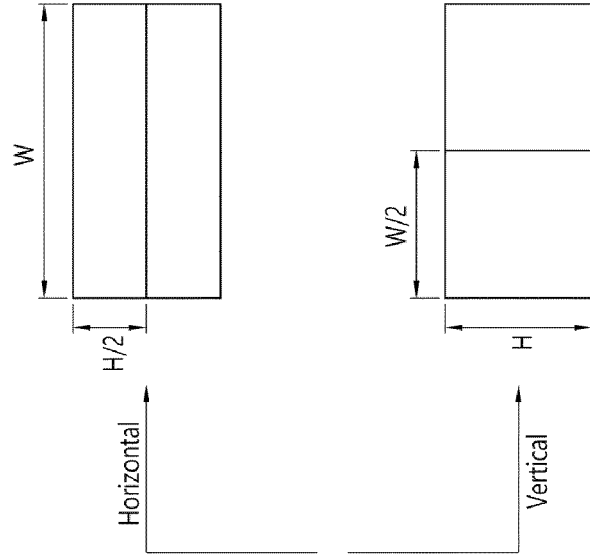

FIG. 17

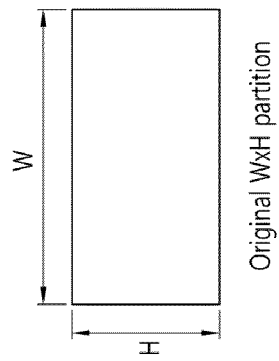
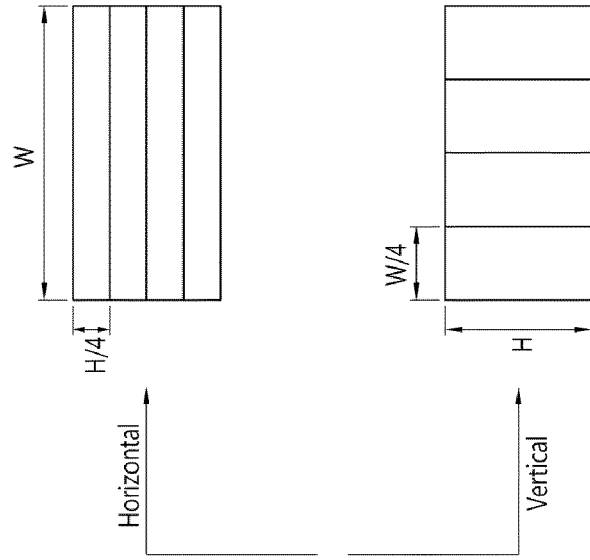

FIG. 18

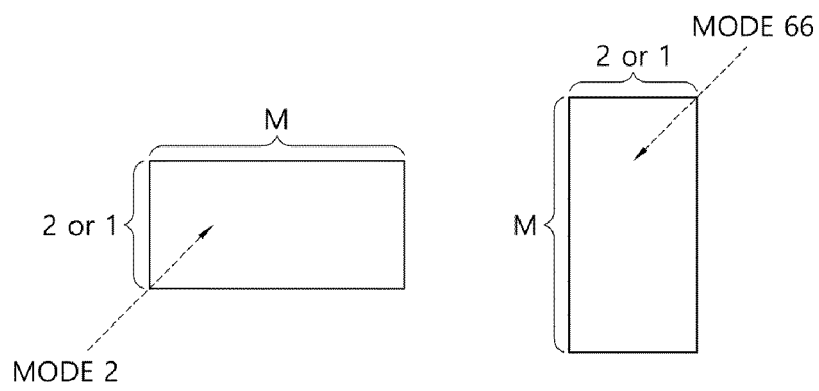

FIG. 19

1	9
2	10
3	11
4	12
5	13
6	14
7	15
8	16

(a)

1	2	3	4	5	6	7	8
9	10	11	12	13	14	15	16

(b)

FIG. 20

1	3	5	7	9	11	13	15
2	4	6	8	10	12	14	16

1	3
2	5
4	7
6	9
8	11
10	13
12	15
14	16

FIG. 21

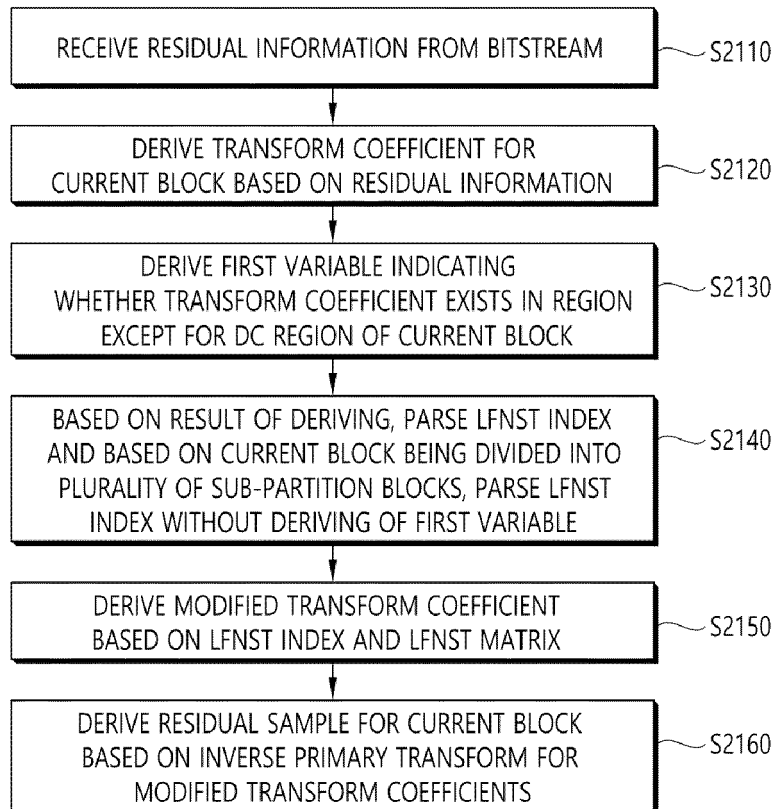

FIG. 22

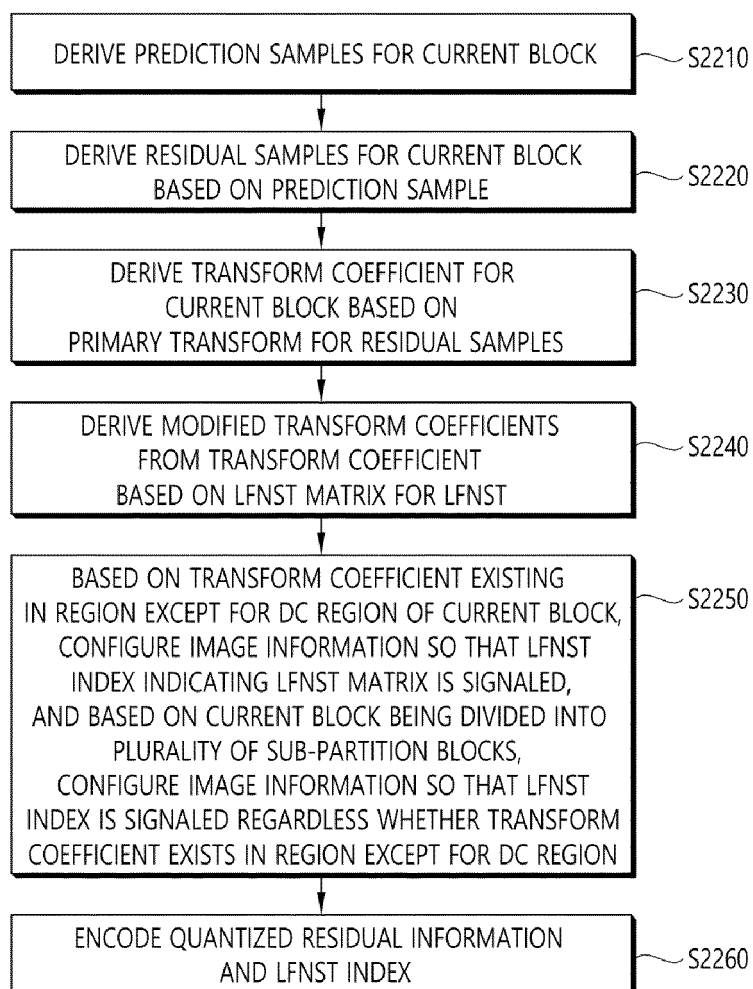
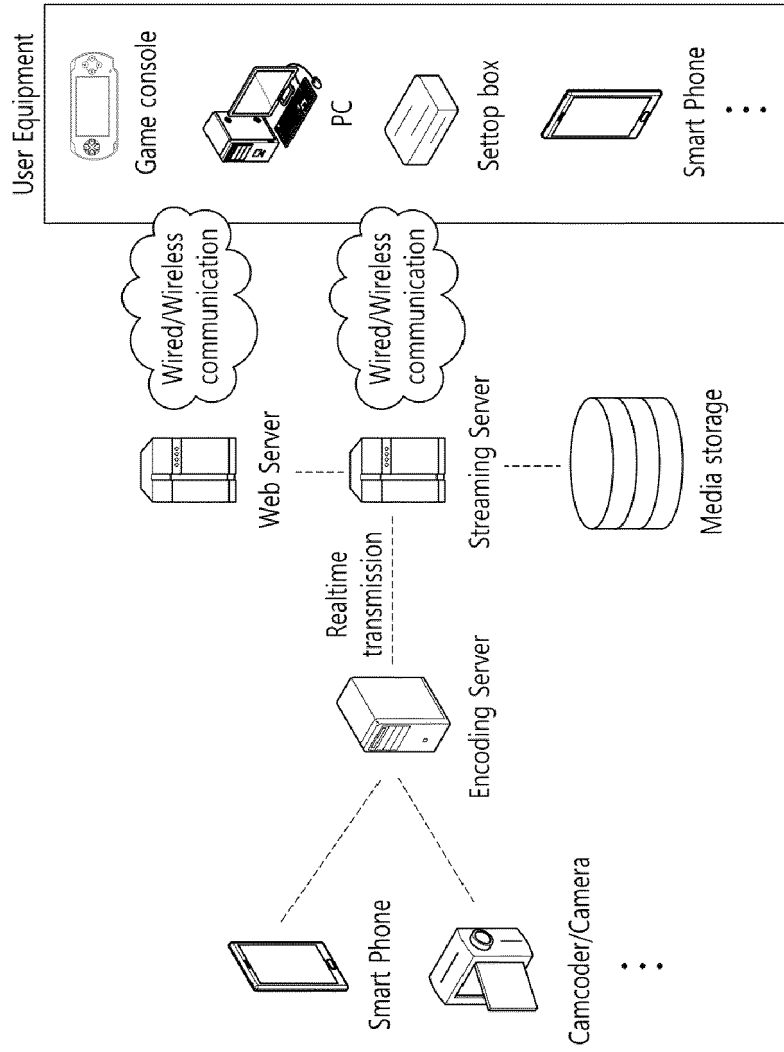

FIG. 23



REFERENCES CITED IN THE DESCRIPTION

This list of references cited by the applicant is for the reader's convenience only. It does not form part of the European patent document. Even though great care has been taken in compiling the references, errors or omissions cannot be excluded and the EPO disclaims all liability in this regard.

Non-patent literature cited in the description

- **BROSS B et al.** *Versatile Video Coding (Draft 6)*, (JVET-O2001 [0004])
- **JIANLE CHEN et al.** *Algorithm description for Versatile Video Coding and Test Model 6 (VTM 6)*, (JVET-O2002-v2 [0004])
- **JUNG (WILUSGROUP) J et al.** *Non-CE6: Simplified LFNST signalling*, (JVET-O0472 [0004])