

(19)



Europäisches Patentamt

European Patent Office

Office européen des brevets



(11)

**EP 0 578 624 B1**

(12)

**EUROPEAN PATENT SPECIFICATION**

(45) Date of publication and mention  
of the grant of the patent:  
**10.02.1999 Bulletin 1999/06**

(51) Int. Cl.<sup>6</sup>: **A47B 96/02**

(21) Application number: **93850115.2**

(22) Date of filing: **01.06.1993**

**(54) Shelving arrangement**

Einrichtung für Regale

Disposition pour étagères

(84) Designated Contracting States:  
**AT BE CH DE DK ES GB GR IT LI NL**

(30) Priority: **10.06.1992 SE 9201776**

(43) Date of publication of application:  
**12.01.1994 Bulletin 1994/02**

(73) Proprietor:  
**Sintek International AB**  
**S-118 25 Stockholm (SE)**

(72) Inventor: **Alneng, Carl-Göran**  
**S-118 25 Stockholm (SE)**

(74) Representative: **Nihlmark, Bengt**  
**B. NIHLMARK AB,**  
**Box 7701**  
**103 95 Stockholm (SE)**

(56) References cited:

<b>DE-A- 1 429 701</b>	<b>DE-U- 8 716 429</b>
<b>GB-A- 924 667</b>	<b>US-A- 2 263 837</b>
<b>US-A- 4 154 419</b>	<b>US-A- 5 004 302</b>

**EP 0 578 624 B1**

Note: Within nine months from the publication of the mention of the grant of the European patent, any person may give notice to the European Patent Office of opposition to the European patent granted. Notice of opposition shall be filed in a written reasoned statement. It shall not be deemed to have been filed until the opposition fee has been paid. (Art. 99(1) European Patent Convention).

## Description

[0001] The present invention relates to a shelving arrangement including shelves for suspension by shelf standards by means of hooks provided at the back of the shelves and shaped for engagement with corresponding apertures formed in the shelf standards.

[0002] The shelves can have, for example, a square, rectangular or triangular form and be supported by perforated squares serving as said shelf standards.

[0003] Conventional and previously known shelving systems mostly comprise perforated tracks or wall-mounted bars with separate brackets, or brackets fixed to the shelves (e.g. GB-A-924667).

[0004] One inconvenience of these systems resides in the fact that the shelves have to be made of a material having a considerable thickness. Alternatively, it is necessary that the points where the hooks engage the support members, such as standards or bars, be located comparatively high up vertically. The high vertical bracket means in the form of side pieces on the shelves often have a concealing effect, as viewed obliquely side-face, on e.g. goods exposed at an exhibition or in a shop. Further inconveniences associated with the conventional shelving systems are i.a. that the parts are bulky in manufacture and transport.

[0005] The main object of the present invention is to provide a shelving arrangement by which costs of manufacture, transport and assembly are minimized, and to increase the possibility to vary the general layout of, for example, an exhibition or a shop.

[0006] Another object is to provide such a shelving arrangement where strong shelves can be manufactured in one piece without the side pieces or end pieces of the shelves hide or conceal articles exposed.

[0007] These and other objects and advantages are attained according to the invention by the characteristic features thereof which are defined in the accompanying claims.

[0008] The invention will be described in greater detail in the following with reference to embodiments illustrated in the drawing. Fig. 1 shows, in perspective, a rectangular shelf provided in accordance with the invention and, in connection therewith, a support standard of a suitable type. Fig. 2 shows, in perspective, a triangular shelf, as viewed from behind. Fig. 3 shows, likewise in perspective, a front view of the shelf of Fig. 2.

[0009] The shelf planes of the shelving arrangement according to the invention are e.g. square, rectangular or triangular, although other forms are conceivable, and their surfaces have along their long sides, short sides or diagonal sides one end piece directed upwards from the plane of the shelf and one end piece directed downwards from the plane of the shelf, the rear edges of said end pieces having hooks for securing the shelves to the shelf standards or hooking them onto the standards. The shelf standards 36 shown here are of a conventional type and may consist of squares having quadratic

cross section and being provided with rows of apertures on one or more sides for receiving the support hooks of the shelves. In the standard illustrated, there is only one row of apertures or slots 38.

5 [0010] The shelf shown in Fig. 1 includes a rectangular shelf plane 10, and at one short side thereof there is a first end piece 12 flanged upwards and at the opposite short side there is a second end piece 14 flanged downwards. The front side 16 of the shelf 10 is flanged downwards, and the rear side 18 of the shelf is flanged upwards. At the rear longitudinal edges of the angle-cut end pieces hooks 20 are formed for suspending, by engaging apertures 38, the shelf on the support standard 36 of the shelving arrangement. Between the rear edge of the upwardly flanged end piece 12 and the upwardly flanged rear side of the shelf proper, an inter-space or gap 22 is provided in order to render it possible to stack several shelves together when stored and transported.

10 [0011] The shelf shown in Figs. 2 and 3 has a triangular shelf plane 24 wherefrom a first end piece 26 is flanged upwards and a second end piece 28 is flanged downwards. The end pieces 26, 28, which are angle-cut and taper towards the front side of the shelf plane, are provided at their rear edges with a hook 30 for suspension on the support standard 36 of the shelving arrangement.

15 [0012] The rear edges of end pieces 26, 28 are located at a right-angled corner or point of the shelf plane 24, and this corner is provided with a recess 32 so that there is room left for the support standard onto which the shelf is to be suspended. In the case illustrated it has been assumed that the support standard is square and provided with suspension apertures in two adjacent sides. The recess 32 also facilitates stacking of the shelves when stored and transported. At the front end of the shelf plane, where there is no end piece, the plane is flanged downwards to form a front side 34.

20 [0013] The square or rectangular shelves according to Fig. 1 are hooked onto the support standards by the hooks 20 of the upwardly flanged end piece 12 being introduced into the apertures of a first standard. The top hook enters first, after which the hooks 20 of the opposite downwardly flanged end piece 14 are introduced into the apertures of a second cooperating standard. In a similar manner the triangular shelf according to Figs. 2 and 3 is mounted, however, with the upwardly flanged end piece and the downwardly flanged end piece placed at each its side of the same standard.

25 [0014] By arranging the shelves according to the invention such that there is a comparatively large distance between the lowermost and the uppermost hooks 20, 30 on the upwardly flanged and the downwardly flanged end pieces, respectively, the shelves will obtain great stability and support ability. This feature will be obtained by the embodiment shown in Figs. 2 and 3, that has only one hook on either end piece, by the respective hook 30 being located as high up as possible

on the upwardly directed end piece 26, and as far down as possible on the downwardly directed end piece 28.

[0015] By the two end pieces being flanged downwards and upwards, respectively, the shelves will also become nestable. With respect to the rectangular or square shelf, the gap 22 in the corner between the rear edge of the upwardly directed end piece and the upwardly flanged rear side 18 of the shelf will allow also these shelves to be nested completely tight.

#### Claims

1. A shelving arrangement including shelves (10) to be supported by shelf standards (36) by means of hooks (20, 30) provided at the back of the shelves, said hooks being adapted to engage corresponding apertures (38) formed in the shelf standards (36), **characterized** in that each shelf includes along its sides a first end piece (12; 26) directed upwardly from the shelf plane (10; 24) and a second end piece (14; 28) directed downwardly from the shelf plane, the hooks (20; 30) being provided at those ends of the end pieces which face the rear side of the shelf plane.
2. A shelving arrangement according to claim 1, **characterized** in that the shelf has a rectangular or square plan form with a rear side (18) flanged upwards, an inter-space (22) being provided between said upwardly flanged rear side (18) and the first end piece (12) directed upwardly from the shelf plane (10).
3. A shelving arrangement according to claim 1, **characterized** in that the shelf plane (24) is triangular and that the hooked (30) rear ends of the end pieces (26, 28) are located at a corner of the triangular shelf plane.
4. A shelving arrangement according to claim 3, **characterized** in that the shelf plane (10) is provided with a recess (32) at that corner where the rear ends of the end pieces (26, 28) would meet, so that said rear ends terminate at points spaced from the corner.
5. A shelving arrangement according to claim 3 or 4, **characterized** in that the end pieces (26, 28) of the shelf are provided each with one single hook (30) at that end of the rear edge of the end piece which is located most distant from the shelf plane.
6. A shelving arrangement according to claim 3, 4, or 5, **characterized** in that those sides which carry the end pieces (26, 28) form a right angle to one another.
7. A shelving arrangement according to any of claims 1-6, **characterized** in that the side or sides of the shelf plane (10; 24) which have no end piece are flanged upwards or downwards from the shelf plane.
8. A shelving arrangement according to claim 7, **characterized** in that the end piece-free front side (16; 34) of the shelf plane is flanged downwards from said plane.
9. A shelving arrangement according to any of the preceding claims, **characterized** in that the shelf is made of sheet metal and that the end pieces (12, 14; 26, 28) are integral with the shelf plane (10; 24) and flanged 90° from this plane.
10. A shelving arrangement according to any of the preceding claims, **characterized** in that the shelf planes are adapted to cooperate with square support standards (36) provided with rows of apertures in one or more sides.

#### Patentansprüche

1. Regalanordnung mit Regalen (10), die von Regalmasten (36) mit Hilfe von an der Rückseite der Regale angeordneten Haken (20, 30) getragen werden, wobei die Haken vorgesehen sind, in entsprechende, in den Regalmasten (36) ausgebildete Öffnungen (38) eingesetzt zu werden, **dadurch gekennzeichnet**, daß jedes Regal entlang seiner Seiten einen ersten, nach oben aus der Regalebene (10; 24) weisenden Giebelteil (12; 26) und einen zweiten, aus der Regalebene nach unten weisenden Giebelteil (14; 28) umfaßt und wobei die Haken (20; 30) an den Giebeln der Giebelteile angeordnet sind, die zur Rückseite der Regalebene weisen.
2. Regalanordnung gemäß Patentanspruch 1, **dadurch gekennzeichnet**, daß das Regal ein rechteckiges oder quadratisches ebenes Profil mit der Rückseite (18) nach oben angeflanscht aufweist, wobei ein Zwischenraum (22) vorgesehen ist zwischen dieser nach oben angeflanschten Rückseite (18) und dem ersten aus der Regalebene nach oben gerichteten Giebelteil (12).
3. Regalanordnung gemäß Patentanspruch 1, **dadurch gekennzeichnet**, daß die Regal - ebene (24) dreieckig ist und daß die festgehakten rückseitigen Kanten der Giebelteile (26, 28) in einer Ecke der dreieckigen Regalebene liegen.
4. Regalanordnung gemäß Patentanspruch 3,

- dadurch gekennzeichnet**, daß die Regal - ebene (24) mit einer Aussparung (32) an der Ecke versehen ist, wo die rückseitigen Kanten der Giebelteile (26,28) möglicherweise aufeinander treffen, sodaß dies rückseitigen Kanten an von der Ecke entfernten Stellen enden.
5. Regalanordnung gemäß Patentanspruch 3 oder 4, **dadurch gekennzeichnet**, daß die Giebelteile (26, 28) des Regals jeweils mit einem einzigen Haken (30) an dem Ende der rückseitigen Kante des Giebelteiles versehen sind, das am weitesten von der Regalebene entfernt liegt.
6. Regalanordnung gemäß Patentanspruch 3, 4 oder 5, **dadurch gekennzeichnet**, daß die Seiten, die die Giebelteile (26, 28) tragen, miteinander einen rechten Winkel bilden.
7. Regalanordnung gemäß irgendeinem der Patentansprüche 1 bis 6, **dadurch gekennzeichnet**, daß die Seite oder die Seiten der Regalebene (10; 24) die keinen Giebelteil aufweisen, aus der Regalebene nach oben oder nach unten angeflanscht sind.
8. Regalanordnung gemäß Patentanspruch 7, **dadurch gekennzeichnet**, daß die giebelteilmfreie Vorderseite (16; 34) der Regalebene aus dieser Ebene nach unten angeflanscht ist.
9. Regalanordnung gemäß irgendeinem der vorhergehenden Patentansprüche, **dadurch gekennzeichnet**, daß das Regal aus Metallblech besteht und die Giebelteile (12, 14; 26, 28) einen Teil der Regalebene (10; 24) bilden und aus dieser Ebene um 90° angeflanscht sind.
10. Regalanordnung gemäß irgendeinem der vorhergehenden Patentansprüche, **dadurch gekennzeichnet**, daß die Regalebenen vorgesehen sind, mit quadratischen, mit Reihen von Öffnungen auf einer oder mehreren Seiten versehenen Regalmaßen (36) zusammenzuwirken.
- plan de la tablette, les crochets (20, 30) étant prévus à ces extrémités des pièces terminales qui font face au coté arrière du plan de la tablette.
2. Disposition pour étagères selon la revendication 1, caractérisée en ce que la tablette a une forme plane rectangulaire ou carrée avec un côté arrière (18) replié vers le haut, un interstice (22) étant prévu entre ledit côté arrière (18) replié vers le haut et la première pièce terminale (12) dirigée vers le haut à partir du plan de la tablette (10).
3. Disposition pour étagères selon la revendication 1, caractérisée en ce que le plan de la tablette (24) est triangulaire et que les extrémités arrières en forme de crochet (30) des pièces terminales (26, 28) sont situées à un coin du plan triangulaire de la tablette.
4. Disposition pour étagères selon la revendication 3, caractérisée en ce que le plan de la tablette (10) est pourvu d'une encoche (32) sur ce coin où les extrémités arrières des pièces terminales (26, 28) se rencontreraient, de sorte que lesdites extrémités arrières se terminent en des points espacés du coin.
5. Disposition pour étagères selon la revendication 3 ou 4, caractérisée en ce que les pièces terminales (26, 28) de la tablette sont pourvues chacune d'un seul crochet (30) à cette extrémité du bord arrière de la pièce terminale qui est situé le plus loin du plan de la tablette.
6. Disposition pour étagères selon la revendication 3, 4 ou 5, caractérisée en ce que ces côtés qui supportent les pièces terminales (26, 28) forment un angle droit l'un par rapport à l'autre.
7. Disposition pour étagères selon l'une quelconque des revendications 1-6, caractérisée en ce que le côté ou les côtés du plan de la tablette (10, 24) qui n'ont pas de pièce terminale sont repliés vers le haut ou vers le bas à partir du plan de la tablette.
8. Disposition pour étagères selon la revendication 7, caractérisée en ce que le côté avant (16, 34) sans pièce terminale du plan de la tablette est replié vers le bas à partir dudit plan.
9. Disposition pour étagères selon l'une quelconque des revendications précédentes, caractérisée en ce que la tablette est en tôle et que les pièces terminales (12, 14, 26, 28) font partie intégrante du plan de la tablette (10, 24) et sont repliées à 90° à partir de ce plan.
10. Disposition pour étagères selon l'une quelconque des revendications précédentes, caractérisée en ce

## Revendications

1. Disposition pour étagères comprenant des tablettes (10) qui seront soutenues par des montants (36) d'étagère au moyen de crochets (20, 30) prévus à l'arrière des tablettes, lesdits crochets étant adaptés pour s'engrener dans des ouvertures (38) correspondantes formées dans les montants (36) d'étagère, caractérisée en ce que chaque tablette comprend le long de ses côtés une première pièce terminale (12, 26) dirigée vers le haut à partir du plan de la tablette (10, 24) et une deuxième pièce terminale (14, 28) dirigée vers le bas à partir du

que les plans des tablettes sont adaptés pour coopérer avec des montants (36) de soutien carrés pourvus de rangées d'ouvertures sur un ou plusieurs côtés.

5

10

15

20

25

30

35

40

45

50

55

5

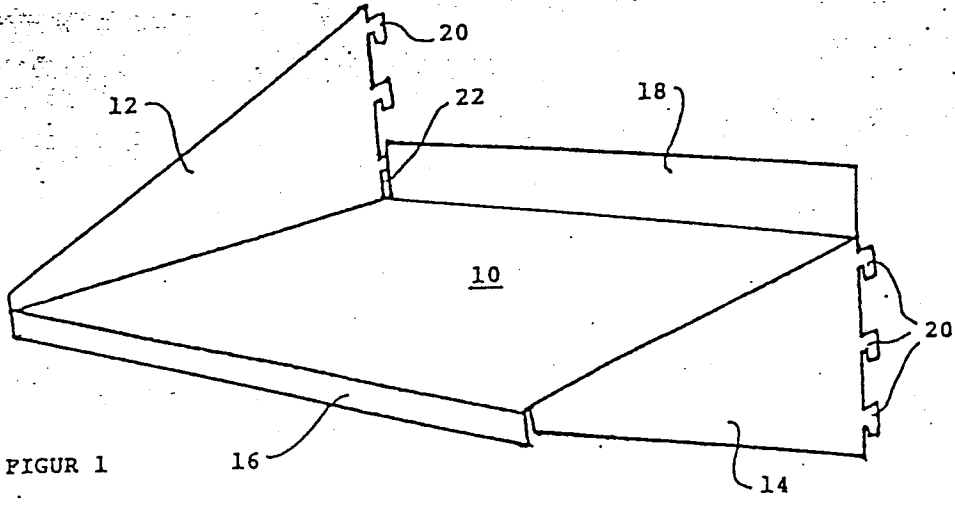

FIGURE 1

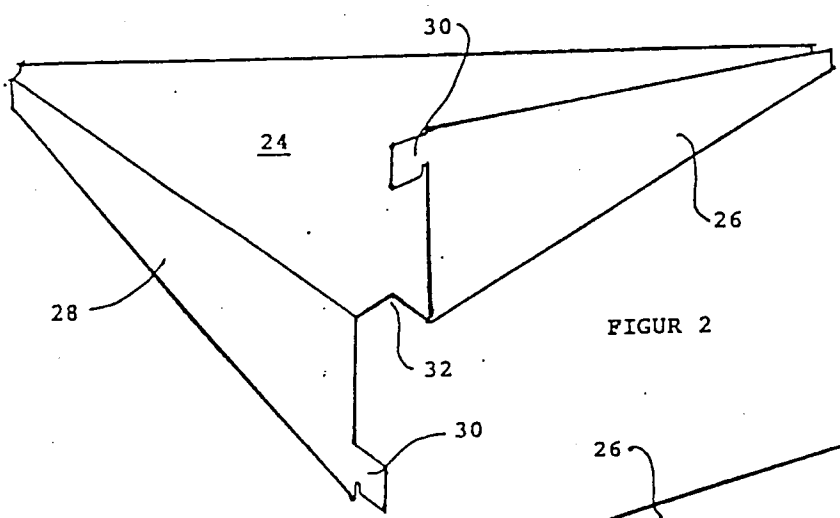

FIGURE 2

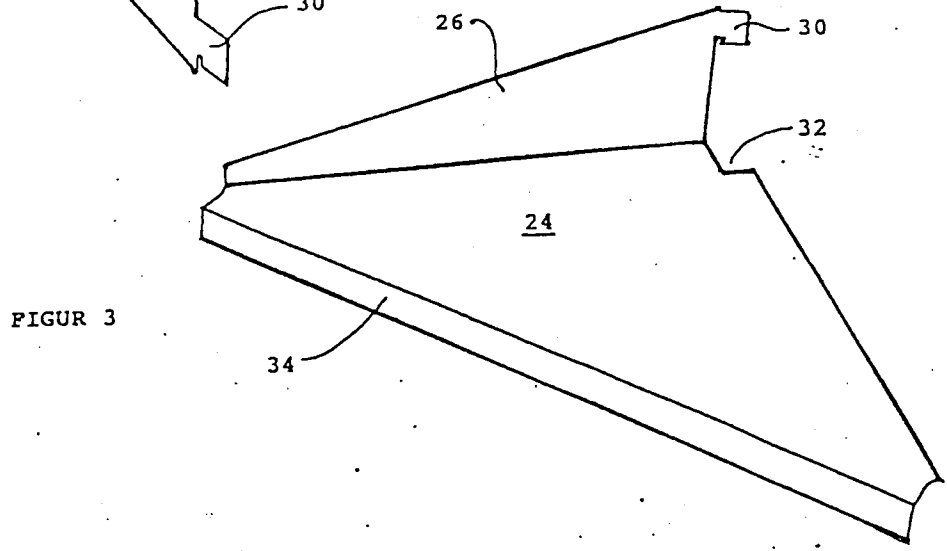

FIGURE 3

