

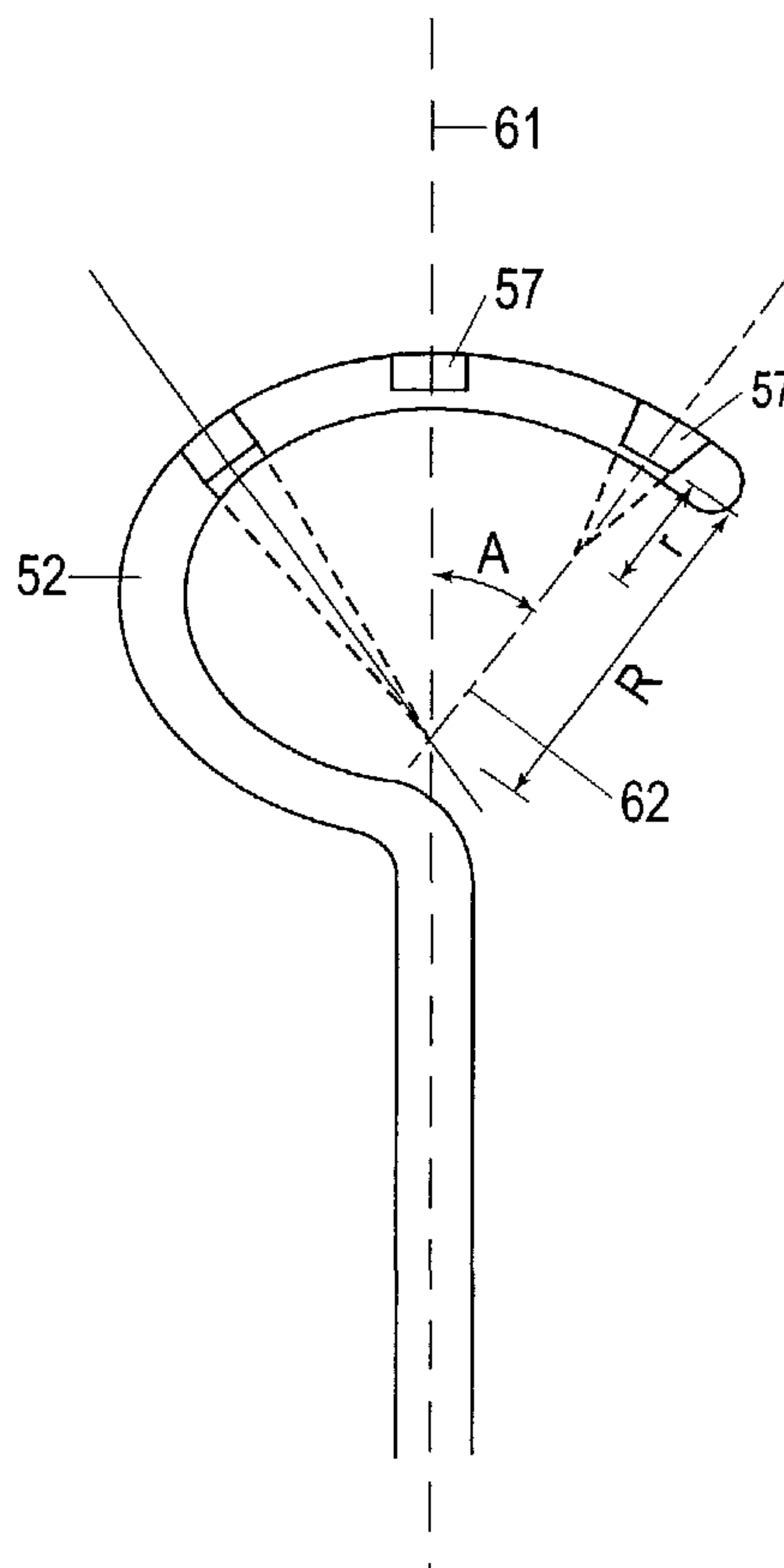

(86) Date de dépôt PCT/PCT Filing Date: 2002/06/14
 (87) Date publication PCT/PCT Publication Date: 2002/12/27
 (85) Entrée phase nationale/National Entry: 2003/12/09
 (86) N° demande PCT/PCT Application No.: AU 2002/000780
 (87) N° publication PCT/PCT Publication No.: 2002/103794
 (30) Priorité/Priority: 2001/06/15 (PR 5705) AU

(51) Cl.Int.⁷/Int.Cl.⁷ H01L 25/075, H01L 23/495
 (71) Demandeur/Applicant:
LEDNIUM PTY LIMITED, AU
 (72) Inventeurs/Inventors:
JEGANATHAN, BALU, AU;
MONTAGNAT, JOHN ALBERT, AU
 (74) Agent: BERESKIN & PARR

(54) Titre : PROCEDE DE FABRICATION D'UNE LAMPE
 (54) Title: A METHOD OF PRODUCING A LAMP



(57) **Abrégé/Abstract:**

A method of producing a lamp, including mounting light emitting junctions on a support structure (52) such that the junctions adopt a three-dimensional array. The support structure may be a curved lead frame, which is also claimed. The conductors may be in a part spherical configuration. The light emitting junctions may be mounted in recesses (57) in the curved conductors, the recesses acting as an optical guide controlling the direction of light output from the junction.

(12) INTERNATIONAL APPLICATION PUBLISHED UNDER THE PATENT COOPERATION TREATY (PCT)

(19) World Intellectual Property Organization
International Bureau(43) International Publication Date
27 December 2002 (27.12.2002)

PCT

(10) International Publication Number
WO 02/103794 A1

- (51) International Patent Classification⁷: **H01L 25/075**,
23/495
- (21) International Application Number: PCT/AU02/00780
- (22) International Filing Date: 14 June 2002 (14.06.2002)
- (25) Filing Language: English
- (26) Publication Language: English
- (30) Priority Data:
PR 5705 15 June 2001 (15.06.2001) AU
- (71) Applicant (for all designated States except US): **SYS-
TEMAX PTY. LTD.** [AU/AU]; Suite 3, Level 7,
Chatswood Central, North Tower, 1-5 Railway Street,
Chatswood, New South Wales 2067 (AU).
- (72) Inventors; and
(75) Inventors/Applicants (for US only): **JEGANATHAN,
Balu** [AU/AU]; 28 Manhattan Terrace, Rowville, Victoria
3178 (AU). **MONTAGNAT, John, Albert** [AU/AU]; 59
Old Lilydale Road, East Ringwood, Victoria 3135 (AU).
- (74) Agents: **HENSHAW, Damon** et al.; Davies Collison Cave,
1 Little Collins Street, Melbourne, Victoria 3000 (AU).
- (81) Designated States (national): AE, AG, AL, AM, AT, AU,
AZ, BA, BB, BG, BR, BY, BZ, CA, CH, CN, CO, CR, CU,
CZ, DE, DK, DM, DZ, EC, EE, ES, FI, GB, GD, GE, GH,
GM, HR, HU, ID, IL, IN, IS, JP, KE, KG, KP, KR, KZ, LC,
LK, LR, LS, LT, LU, LV, MA, MD, MG, MK, MN, MW,
MX, MZ, NO, NZ, OM, PH, PL, PT, RO, RU, SD, SE, SG,
SI, SK, SL, TJ, TM, TN, TR, TT, TZ, UA, UG, US, UZ,
VN, YU, ZA, ZM, ZW.
- (84) Designated States (regional): ARIPO patent (GH, GM,
KE, LS, MW, MZ, SD, SL, SZ, TZ, UG, ZM, ZW),

[Continued on next page]

(54) Title: A METHOD OF PRODUCING A LAMP

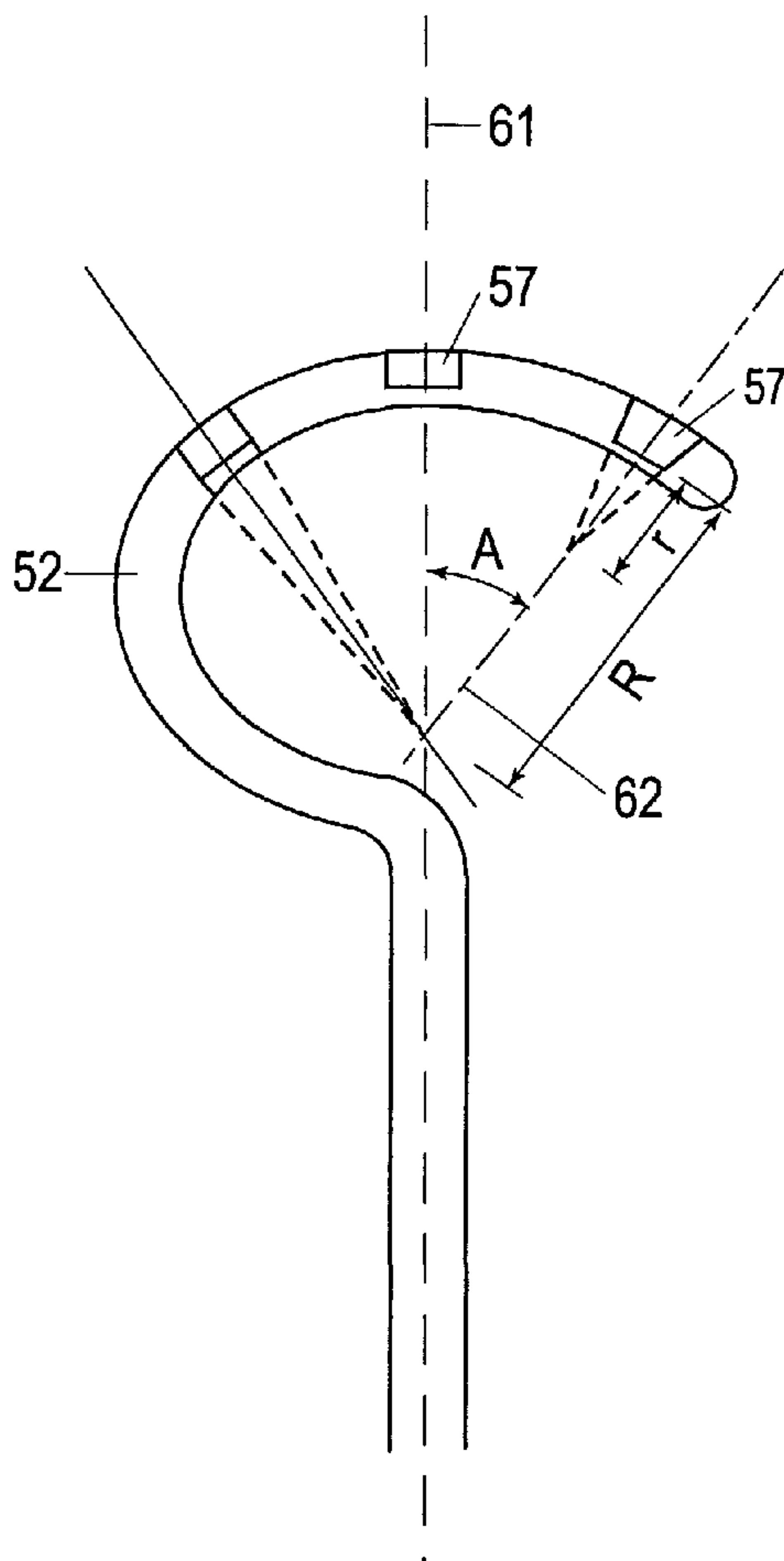

(57) Abstract: A method of producing a lamp, including mounting light emitting junctions on a support structure (52) such that the junctions adopt a three-dimensional array. The support structure may be a curved lead frame, which is also claimed. The conductors may be in a part spherical configuration. The light emitting junctions may be mounted in recesses (57) in the curved conductors, the recesses acting as an optical guide controlling the direction of light output from the junction.

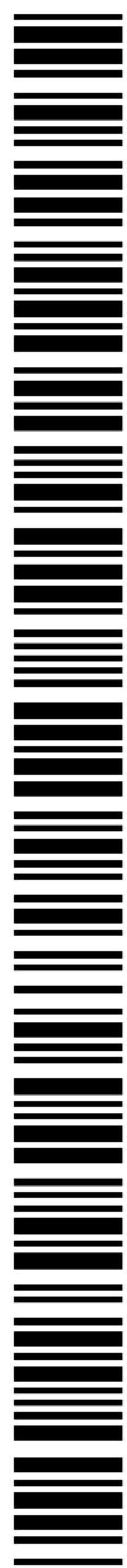

WO 02/103794 A1

WO 02/103794 A1



Eurasian patent (AM, AZ, BY, KG, KZ, MD, RU, TJ, TM),
European patent (AT, BE, CH, CY, DE, DK, ES, FI, FR,
GB, GR, IE, IT, LU, MC, NL, PT, SE, TR), OAPI patent
(BF, BJ, CF, CG, CI, CM, GA, GN, GQ, GW, ML, MR,
NE, SN, TD, TG).

For two-letter codes and other abbreviations, refer to the "Guidance Notes on Codes and Abbreviations" appearing at the beginning of each regular issue of the PCT Gazette.

Published:

— *with international search report*

- 1 -

A METHOD OF PRODUCING A LAMP

Field of the Invention

The present invention relates to a method of producing a lamp, particularly an LED lamp, and a lead frame for use in the lamp.

5 Summary of the Invention

In accordance with the present invention, there is provided a method of producing a lamp, including mounting light emitting junctions on a support structure such that the junctions adopt a three-dimensional array.

10 Preferably, the method further includes locating the junctions in respective recesses formed in the support structure, the recesses functioning as an optical guide for controlling a direction of light output from the associated junction.

Preferably, the support structure includes a plurality of conductors and the method further includes forming the conductors in a curved configuration, which is preferably a part spherical configuration.

15 Preferably, the conductors are provided in the form of a lead frame.

Preferably, the method further includes moving the lead frame relative to a forming station and engaging a punch and die, from opposed sides of the lead frame, to form the recesses. The recesses may be formed in a single action or, alternatively, formed sequentially, with the punch and die being moved relative to the lead frame after each recess forming action
20 so that the punch and die are appropriately positioned for a subsequent recess forming action.

Preferably, the lead frame is supported on a carrier and the method includes moving the carrier so as to present each recess to a mounting station whereat the junctions are mounted to the conductors. The carrier is preferably rotatable about first and second orthogonal
25 axes to align the respective recess with the mounting station and the junctions are mounted

- 2 -

in the respective recesses by advancing the junctions and associated conductors relative to each other along a third axis, which is preferably orthogonal to the first and second axes.

Each junction is preferably electrically connected to two of the conductors via intermediate conductors. The intermediate conductors may be connected to allow for independent
5 control of at least two of the junctions, by controlling electric current through the associated conductors, to which each junction is connected. The junctions may further be electrically coupled to the conductors in groups which are separately controllable.

The method preferably includes application of a common phosphor over at least two adjacent junctions and, more preferably, encapsulation of the support structure and
10 junctions, in a globe portion.

In another aspect, there is provided a lead frame including a plurality of conductors formed in a curved configuration, for supporting light emitting junctions in a three-dimensional array. The lead frame preferably includes recesses for receipt of a respective one of the junctions.

15 In another aspect, there is provided a lamp formed in accordance with the above-described method.

In yet another aspect, there is provided a method of operating the above described lamp, formed with conductors and light emitting junctions electrically connected therebetween, including controlling electrical current through individual ones of the conductors so as to
20 independently control light output from the junctions coupled thereto.

Brief Description of the Drawings

The invention will be described in more detail with reference to the drawings in which:

Figure 1 is a side-view of an LED lamp;

Figure 2 is a plan-view of the lamp of Figure 1;

25 Figure 3 is a circuit diagram for the lamp of Figures 1 and 2;

Figure 4 is a diagrammatic cross-sectional view of a second LED lamp;

Figure 5 is a circuit diagram of the lamp of Figure 4;

- 3 -

- Figure 6 is a cross-sectional view of the lamp of Figure 4;
Figure 7 is a plan view of the lamp of Figure 4;
Figure 8 is a representation of an illumination pattern of the lamp of Figures 4 to 7;
Figure 9 is a plan view of a third lamp;
5 Figure 10 is a circuit diagram for the lamp of Figure 9;
Figure 11 is a front view of the lamp of Figure 9;
Figure 12 is a side view of the lamp of Figure 9;
Figure 13 is a side view of a lens for fitting on the lamp of Figure 9;
Figure 14 is a cross-sectional view taken along the line X-X shown in Figure 11;
10 Figure 15 is a cross-sectional view taken along the line Y-Y shown in Figure 12;
Figure 16 is a representation of the illumination pattern produced by the lamp of Figures 9 to 12;
Figure 17 is a schematic flow chart illustrating steps for producing a lamp;
Figure 18 is a diagrammatic perspective view of a lead frame arranged for a recess forming
15 operation;
Figure 19 is a perspective view of the lead frame on a carrier;
Figure 20 is a cross-sectional view of the lead frame;
Figure 21a) is a plan view of the lead frame with junctions and intermediate conductors attached;
20 Figure 21b) is a cross-sectional view of the lead frame, taken along the line A-A, shown in Figure 21a).
Figure 22 is a plan view of another lead frame with junctions attached;
Figure 23 is a plan view of an alternative lead frame construction;
Figure 24 is a perspective view of a lamp, formed from the lead frame of Figure 23; and
25 Figure 25 is a perspective view of another lamp.

Detailed Description of a Preferred Embodiment

The lamp 1, as shown in Figure 1, includes a globe portion 2 with a cylindrical base 3 and a parabolic end 4, configured to enhance illumination output in an axial direction of the lamp. The lamp also includes first and second terminals, which are preferably in the form
30 of conductors 5,6 which are embedded within the globe portion 2. The terminal 5 has a

- 4 -

support platform 7 to which is mounted an integrated circuit wafer 8. In the example given, the wafer includes two junctions which are arranged substantially adjacent to each other so that a common layer of fluorescent material, such as a phosphor layer, may be applied over both junctions. Intermediate conductors 9 to 12 electrically couple the junctions to the respective terminals 5,6 so that the LED junctions 14,15 are arranged in reverse polarity, as indicated in the circuit diagram Figure 3. A resistive element 16 is provided between a further conductor 13 (connecting the intermediate conductors 11 and 12) and the terminal 5.

The conductors 5,6, intermediate conductors 9 to 13, and wafer 8 are all embedded within the globe portion 2 so that the lamp is presented as a robust unitary structure. The reverse polarity of the junctions allows the lamp to be connected to a power source without concern for polarity, as compared to the case with a conventional LED arrangement. The use of a single phosphor layer, common to each of the junctions, also simplifies manufacture and provides an aesthetic advantage in that the light from either junction is perceived to originate from a single source.

In a preferred form of the LED lamp, the following specifications may apply:

	NOMINAL SIZE	-	9.5mm diameter
	LIGHT COLOUR	-	WHITE
	GLOBE COLOUR	-	WATER CLEAR
20	LIGHT INTENSITY	-	SUPERBRIGHT
			TYPICAL LIGHT OUTPUT > 500mCd @ 20mA
	GUARANTEED LIFE	-	30,000 HOURS
	FOCUS	-	HALF ANGLE 15° typ.
	BASE STYLE	-	INTERCHANGEABLE WITH WEDGE TYPE LAMPS
25	LEAD DIMENSIONS	-	6mm nom. OUTSIDE BASE WEDGE
	SUPPLY VOLTAGE	-	12VOLTS nom. {>11.5<14 volts AC or DC}
	FORWARD CURRENT	-	20 +8/-3 mA @ 12Volts
	FORWARD VOLTAGE	-	3.6 min(typ) 4.0max. @ 20mA
	REVERSE VOLTAGE	-	5Volts min.

- 5 -

POWER DISSIPATION - LED JUNCTIONS 120Mw
 RESISTOR 170mW
 REVERSE CURRENT - 50×10^{-3} mA max. @ 5V
 INTERNAL RESISTOR - 430 ohms nom.

5 It should, however, be appreciated that the size configuration and operating parameters of any of the component parts of the lamp may vary, as required and the number of LED junctions may also be increased to suit illumination needs.

A second lamp 20 is now described with reference to Figures 4 to 8. The lamp 20 is generally similar in construction to that of Figures 1 to 3, insofar as first and second
 10 terminals 21 and 22 are provided, in the form of conductors 23,24 embedded in a globe portion 25, together with additional conductors 26,27. Each of the conductors 23,26 and 27 have a respective recess 28, to provide support structure for receiving an associated junction, indicated by reference numerals 29,30,31. The junctions are covered by a
 15 common layer of phosphor 35 and are electrically coupled between each respective conductors 23,26,27 to which they are mounted, and the adjacent conductor via intermediate conductors 32,33,34. In the example shown, the junctions are serially connected, as represented by the circuit diagram of Figure 5.

All of the conductors 23, 24,26,27 are preferably formed in a two dimensional lead frame structure 40 shown in Figure 6, to allow ease of manufacture and reliability in directly
 20 positioning the junctions 29,30,31 before application of the phosphor layer 35 within and before application of the globe portion 25. As can be seen from both Figures 6 and 7, the junctions 29,30,31 are arranged in a generally linear array, with the conductors 23,27 projecting above the conductor 26 so that the overall illumination generated by the junctions will be somewhat enhanced on-axis, as represented in Figure 8 by curve A.

25 The lamp 20 may also be provided with a lens 41 which is fitted to the globe portion 25 and shaped so as to modify the light generated by the lamp to produce, for example, the illumination pattern represented by curve B in Figure 8, whereby the output illumination is somewhat more evenly distributed.

- 6 -

Turning now to Figures 9 to 16, a third lamp 50 is illustrated. Again, the lamp 50 is in general similar to the previous lamp construction insofar as a plurality of conductors 51,52,53 and 54 are embedded within a unitary globe portion 55 and have light emitting junctions 56 mounted in respective recesses 57 and covered by a common layer of fluorescent material 59. Each junction is again electrically coupled to the respective conductor to which it is mounted and an adjacent conductor via intermediate conductors 58 so as to form the circuit illustrated in Figure 10. Each of the conductors 51 to 54, in this instance, however, carrying three junctions 56.

The conductors 51 to 54 are curved within the globe portion 55 so as to support the junctions on an imaginary curved surface such as a spheroid and, in that manner, the illumination generated by the lamp 50 will have an appearance of emanating from a small, generally spheroid point like source. A lens 60 may also be provided for modifying the output of the junctions to produce a more even distribution pattern such as represented by curve C in Figure 16, which is the illumination output observed from a plan view of the lamp 50, i.e. when the lamp is seen from the same direction as viewed in Figure 9.

In addition to modifying the light output by using the lens 60, it is also possible to arrange the conductors in any desired configuration and the construction of the recesses 57 may also be used to assist in controlling the directional output of the light emitted from the various junctions. In particular, the configuration of each recess may be such that for example, the recess side walls act as optical guides to control the direction and/or angle of divergence of light emitted from each junction.

More specifically, the shape of each recess and its effect on the light output from the junctions will now be described in more detail with reference to Figures 14 and 15, which show cross-sectional views of the relevant conductors taken along the lines X-X and Y-Y shown in Figures 11 and 12 respectively.

The recesses 57 containing the LED junctions are positioned and shaped in the conductors 51,52,53 so that the beams of light emerging from the recesses may be combined in free space outside the lamp 50 in predictable patterns determined by the radius of the imaginary part spherical surface designated 'R', the distance from the LED junction in the recess to

- 7 -

the intersection of the imaginary extension of the sides of a recess - designated 'r' and the angle 'A' between the centre line 61 of the lamp 50 and a centre line 62 passing through the perpendicular to any other LED junction.

The radius 'R' of the imaginary spherical surface is the distance from the intersection of those centre lines to the LED junction within the recess. The angle between the sides of a recess determines the value of the 'r'.

In the limiting case where 'r' is equal to or greater than 'R', the light from each LED junction will be shaped by the recesses into beams which do not cross, regardless of the value of angle 'A'. For all values of 'r' less than 'R' it will be possible to have the light beam from each LED junction coincide with the edges of the light beams from adjacent LED junctions. The exact positioning in this instance will be determined by the ratio R/r and the value of angle 'A'.

As may be appreciated, the above described lamps allow considerable scope for obtaining a light source using junction diodes, with a predetermined one of a variety of output illumination patterns whilst maintaining a generally simple construction. A particular advantage is that the various junctions are of small size and may be configured to produce a light output which may be perceived by the naked eye to be emanating from a single point source of light.

A method of producing a lamp is now described, with reference to Figures 17 to 24. The method includes three main stages: stage 100 is the formation of a suitable lead frame; stage 101 is the attachment of junctions to the lead frame; and stage 102 is the final packaging stage.

Stage 100 includes provision of a flat lead frame, at step 103, formation of conductors of the lead frame into a part spherical surface, at step 104, and the formation of recesses in the conductors, at step 105, followed by surface treatment step 106.

Figure 18 shows a lead frame 110, between steps 104 and 105. The lead frame 110 is provided in a generally elongate strip 111, divided into sections 112, which will ultimately be separated to form individual lamps. Each section 112 includes a plurality of conductors

- 8 -

113, 114, 115 formed into a curved configuration which is preferably part spherical. The conductors may be formed in that configuration by any suitable process such as by inserting the strip 111 in a press or the like.

In order to form the recesses, the part spherical portion of the lead frame is fitted over a correspondingly shaped tool 116, at a forming station, where a punch (not shown) is engaged with the conductors 113, 114, 115, from an opposite side of the lead frame to that of the die, to form recesses in the conductors by action of the punch deforming the conductors into an associated die 117 provided in the tool 116. The recesses may be formed sequentially and for that purpose, the tool is preferably rotatably movable relative to the lead frame so that the die can be rotated to any desired position where a recess is required. In that manner, a single punch, which is rotated in unison, and die 117 can be used to form all of the recesses in any desired array. Alternatively, the tool 116 may have a predefined array of die 117 and the punch configured appropriately so that all of the recesses are formed in a single action. The particular positioning and configuration of the recesses can be selected to optimise output, as required, since the recesses act as optical guides, as discussed above specifically in relation to Figures 9 to 16, to define the directional output while the number of recesses will determine the maximum output intensity.

In any event, the lead frame 110, can be mounted on a carrier 119, as shown in Figure 19, for stage 101, where light emitting junctions are mounted in the recesses 120. The carrier 119 is itself rotatable on a shaft 121, for pivotal movement about an x-axis, and a shaft 122, for pivotal movement about a y-axis. As such, the lead frame can be positioned at a mounting station (not shown) and rotated about the x,y axes relative to the mounting station in order for each one of the recesses 120 to be sequentially presented for receipt of an associated junction. Figure 20 shows a cross-section of one of the stations 112 and, in particular, the part spherical configuration of conductor 114. A curve 123 represents the possible path of spherical translation of the conductor 114 which is achievable by rotating the lead frame 110 about axes 121,122. Line 124 represents an equivalent rotation of the tool 116 away from the z-axis, which in turn defines the operating angle 125 within which recesses 120 may be formed.

- 9 -

When each of the recesses is appropriately presented at the mounting station, the associated light emitting device or die, referred to for simplicity as junction 130, as shown in Figure 21, is inserted into the recess along a third axis, which is preferably in a z-axis direction, and bonded in place in accordance with step 107 of stage 101 of processing. At
5 that time, or subsequent thereto, intermediate conductors 131 are attached at step 108 to electrically connect the junctions to adjacent conductors. The junctions shown in Figure 21 are arranged in an electrically parallel configuration, however, the positioning and coupling of the junctions may be in any desired configuration, such as shown in Figure 22, where each junction is coupled to a common central conductor 114 and a separate radially
10 arranged conductor 132 to allow the light intensity from each of the junctions to be separately controlled by independently controlling the power supplied to the conductors. Another possible configuration of recesses 120 is shown in Figure 23. In any of the configurations, various ones of the junctions can be electrically connected in groups so that the light intensity from each of the groups can be independently controlled.

15 Once the LED junctions have been mounted in place and the intermediate conductors connected, a phosphor is applied over the junctions at processing step 109 of stage 101. The phosphor is preferably applied to at least two adjacent LED junctions.

The lead frame 110 is then transferred to a final stage 102 of processing to form the lamp 140 shown in Figure 24. Stage 102 includes separating the sections 112, removing excess
20 lead frame material and either compression moulding, at step 135 or epoxy moulding, at step 136, a globe portion 137 (see Figure 24) about the conductors 112, 114, 115. Free ends of the conductors may then be bent into terminals or pins 138, to be inserted in an associated through hole of a typical printed circuit board (PCB) or the like. The resultant lamp 140 may then be tested at step 139 and packaged, if required.

25 Another finished lamp 150 is shown in Figure 25, with an additional moulded body 151 formed beneath the globe portion 137. In this instance, the conductors within the globe portion have not been shown for simplicity, however, the conductors may have a configuration similar to that shown in Figure 22, albeit that more junctions and associated recesses and conductors are provided. Specifically, 18 separately wired junctions are

- 10 -

provided, with 18 associated pins 138 and a further pin 152, for providing electric current to a common conductor within the globe portion 137. As such, 18 different circuits are formed within the lamp 150 and these can be individually addressed and controlled via the pins 138, which are again adapted to fit into PCB, or the like.

- 5 As may be appreciated then, the invention provides a method for producing an LED lamp which optimises output of the LED junctions by positioning the junctions in a three-dimensional array and utilising recesses for optical guides. Further, the construction allows different output of individual junctions or groups of junctions to be independently controlled to vary the intensity of emitted light. Lastly, it is again mentioned that the
- 10 three-dimensional array of the junctions and the configuration of the curved conductors themselves allow for the light from the lamp to have more of an appearance of emanating from a single point or small spherical source, which may be considered an advantage over conventional discrete junction light emitting junction devices.

The above method and LED lamps have been described by way of non-limiting example

15 only, and many modifications and variations may be made thereto without departing from the spirit and scope of the invention as hereinbefore described.

- 11 -

The Claims:

1. A method of producing a lamp, including the steps of:
forming a support structure having a plurality of conductors, at least one of the
5 conductors being curved;
forming recesses in said at least one curved conductor;
mounting a plurality of light-emitting junctions in respective recesses so that said
junctions adopt a three-dimensional array; and
electrically connecting each of said junctions to the conductor having formed
10 therein the recess in which the junction is mounted and to another of said conductors,
whereby at least two of said junctions are controllable independently of each other by
controlling current supplied to the conductors to which said at least two junctions are
electrically connected.
- 15 2. A method as claimed in claim 1, wherein the conductors are formed in a part
spherical configuration.
3. A method as claimed in claim 1, wherein the support structure has three curved
conductors, each having recesses formed therein.
- 20 4. A method as claimed in claim 1, wherein the support structure is provided in the
form of a lead frame including said plurality of conductors.
5. A method as claimed in claim 4, further including engaging a punch and die with
25 the lead frame to form the recesses.
6. A method as claimed in claim 5, wherein the recesses are formed in a single action.
7. A method as claimed in claim 5, wherein the recesses are formed sequentially, and
30 the punch and die are moved relative to the lead frame after each recess forming action so
that the punch and die are appropriately positioned for a subsequent recess forming action.

- 12 -

8. A method as claimed in any one of claims 5 to 7, further including supporting the lead frame on a carrier and moving the carrier so as to present each recess to a mounting station whereat the junctions are mounted in the recesses in the conductors.
- 5 9. A method as claimed in claim 8, wherein the carrier is rotatable about first and second orthogonal axes to align the respective recess with the mounting station and the junctions are mounted in respective recesses by advancing the junctions and associated conductors relative to each other along a third axis.
- 10 10. A method as claimed in any one of claims 1 to 9, wherein each junction is electrically connected to two of the conductors via intermediate conductors.
11. A method as claimed in claim 10, wherein the junctions are electrically coupled to the conductors in groups which are separately controllable.
- 15 12. A method as claimed in any one of claims 1 to 11, further including application of a common phosphor over at least two adjacent junctions.
13. A method as claimed in any one of claims 1 to 12, further including encapsulation
20 of the support structure and junctions in a globe portion.
14. A lead frame for a lamp, including:
a support structure having a plurality of conductors; and
a plurality of recesses formed in the conductors for receiving respective light-
25 emitting junctions;
whereby when said junctions are received in said recesses and each said junction is electrically connected to the conductor having formed therein the recess in which the junction is mounted and to another of said conductors, at least two of said junctions are controllable independently of each other by controlling current supplied to the conductors
30 to which said at least two junctions are electrically connected.

- 13 -

15. The lead frame of claim 14, wherein at least one of said conductors is curved and said junctions adopt a three-dimensional array.
16. The lead frame of claim 14, wherein at least one of the conductors is formed in a
5 part spherical configuration.
17. A method of producing a lamp, including the steps of:
forming a support structure having a plurality of conductors, at least one conductor
being curved; and
10 mounting light-emitting junctions on the at least one curved conductor so that the
junctions adopt a three-dimensional array.
18. The method of claim 17, wherein at least one of the conductors is formed in a part
spherical configuration.
15
19. The method of claim 17 or 18, wherein the junctions are mounted in recesses
formed in the at least one curved conductor.
20. The method of claim 19, further including the step of:
20 electrically connecting each of said junctions to the conductor having formed
therein the recess in which the junction is mounted and to another of said conductors,
whereby at least two of said junctions are independently controllable by controlling current
supplied to the conductors to which said at least two junctions are electrically connected.
- 25 21. A lamp formed in accordance with the method of any one of claims 1 to 13 or 17 to
20.
22. A method of operating a lamp as claimed in claim 21, formed with conductors and
light emitting junctions electrically connected therebetween, including controlling
30 electrical current through individual ones of the conductors so as to independently control
light output from the junctions coupled thereto.

- 14 -

23. A method of producing a lamp, including mounting light emitting junctions on a support structure such that the junctions adopt a three-dimensional array.

5 24. A method as claimed in claim 23, wherein the support structure includes a plurality of conductors and the method further includes forming the conductors in a curved configuration.

10 25. A method as claimed in claim 23, wherein the conductors are formed in a part spherical configuration.

15 26. A method as claimed in claim 23, further including locating the junctions in respective recesses formed in the support structure, the recesses functioning as an optical guide for controlling a direction of light output from the associated junction.

27. A method as claimed in claim 23, wherein the support structure is provided in the form of a lead frame so as to include a plurality of conductors.

20 28. A method as claimed in claim 27, wherein the conductors are formed in a part spherical configuration.

29. A method as claimed in claim 27 or 28, further including engaging a punch and die with the lead frame, to form the recesses.

25 30. A method as claimed in claim 27, wherein the recesses are formed in a single action.

30 31. A method as claimed in claim 27, wherein the recesses are formed sequentially, and the punch and die are moved relative to the lead frame after each recess forming action so that the punch and die are appropriately positioned for a subsequent recess forming action.

- 15 -

32. A method as claimed in any one of claims 29 to 31, further including supporting the lead frame on a carrier and moving the carrier so as to present each recess to a mounting station whereat the junctions are mounted to the conductors.
- 5 33. A method as claimed in claim 32, wherein the carrier is rotatable about first and second orthogonal axes to align the respective recess with the mounting station and the junctions are mounted in the respective recess by advancing the junctions and associated conductors relative to each along a third axis.
- 10 34. A method as claimed in any one of claims 27 to 32, wherein each junction is electrically connected to two of the conductors via intermediate conductors.
35. A method as claimed in claim 34, wherein the intermediate conductors are connected to allow for independent control of at least two of the junctions, by controlling
15 electric current through the associated conductors, to which each junction is connected.
36. A method as claimed in claim 35, wherein the junctions are electrically coupled to the conductors in groups which are separately controllable.
- 20 37. A method as claimed in any one of claims 23 to 36, further including application of a common phosphor over at least two adjacent junctions.
38. A method as claimed in any one of claims 23 to 37, further including encapsulation of the support structure and junctions, in a globe portion.
25
39. A lead frame including a plurality of conductors formed in a curved configuration, for supporting light emitting junctions in a three-dimensional array.
40. A lead frame as claimed in claim 39, further including recesses for receipt of a
30 respective one of the junctions.

- 16 -

41. A lamp formed in accordance with the method of any one of claims 23 to 38.
42. A method of operating a lamp as claimed in claim 41, formed with conductors and light emitting junctions electrically connected therebetween, including controlling
5 electrical current through individual ones of the conductors so as to independently control light output from the junctions coupled thereto.

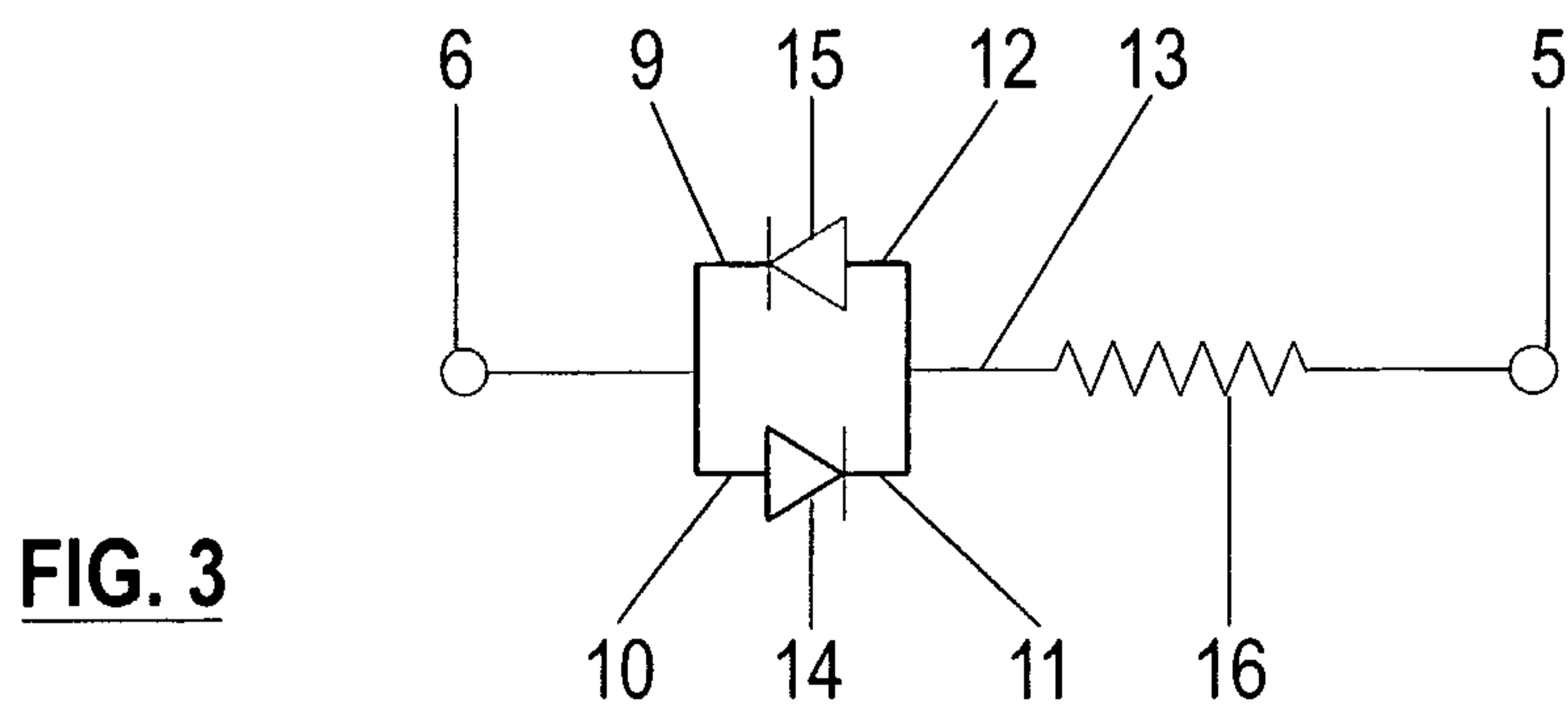
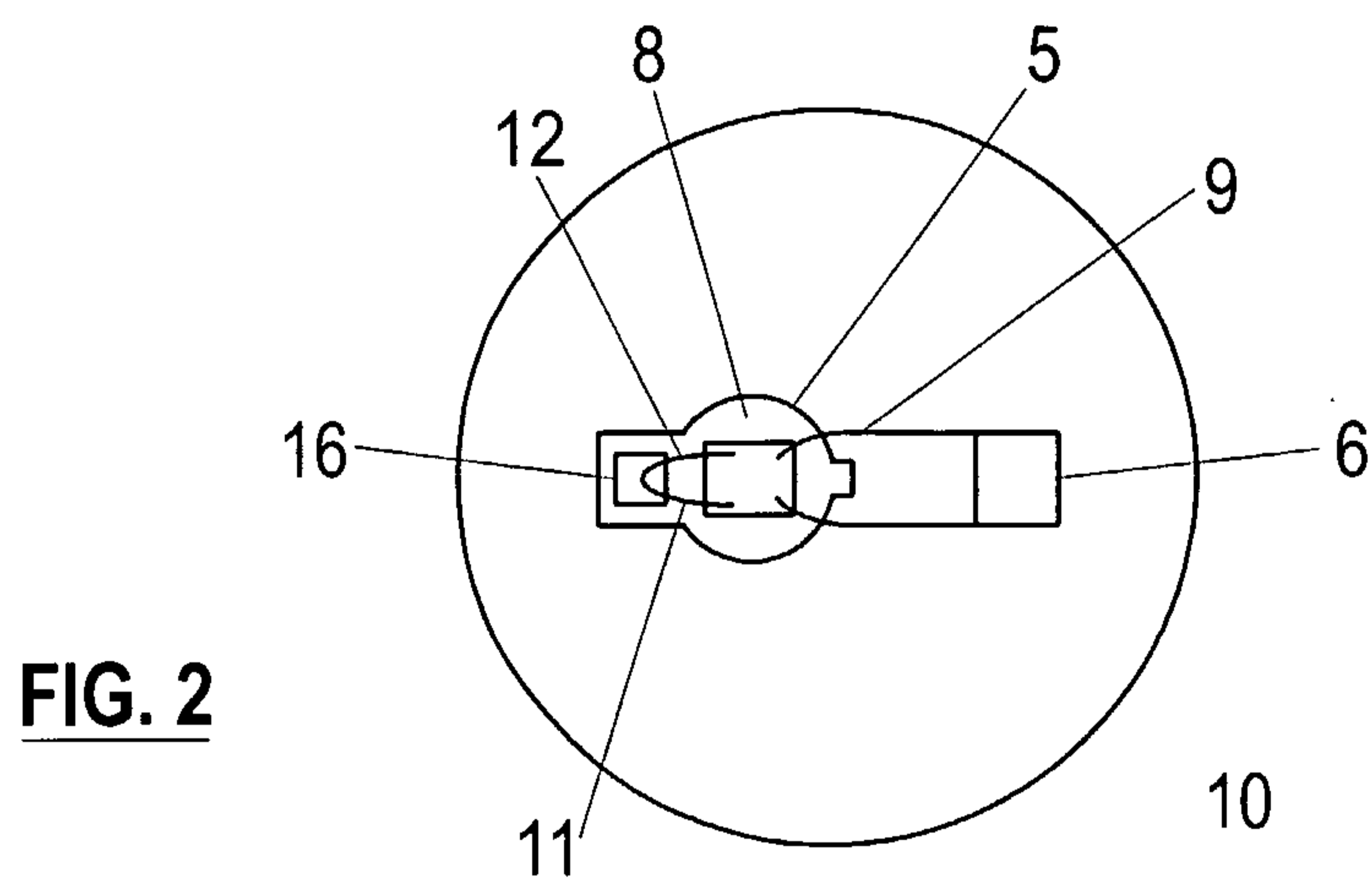
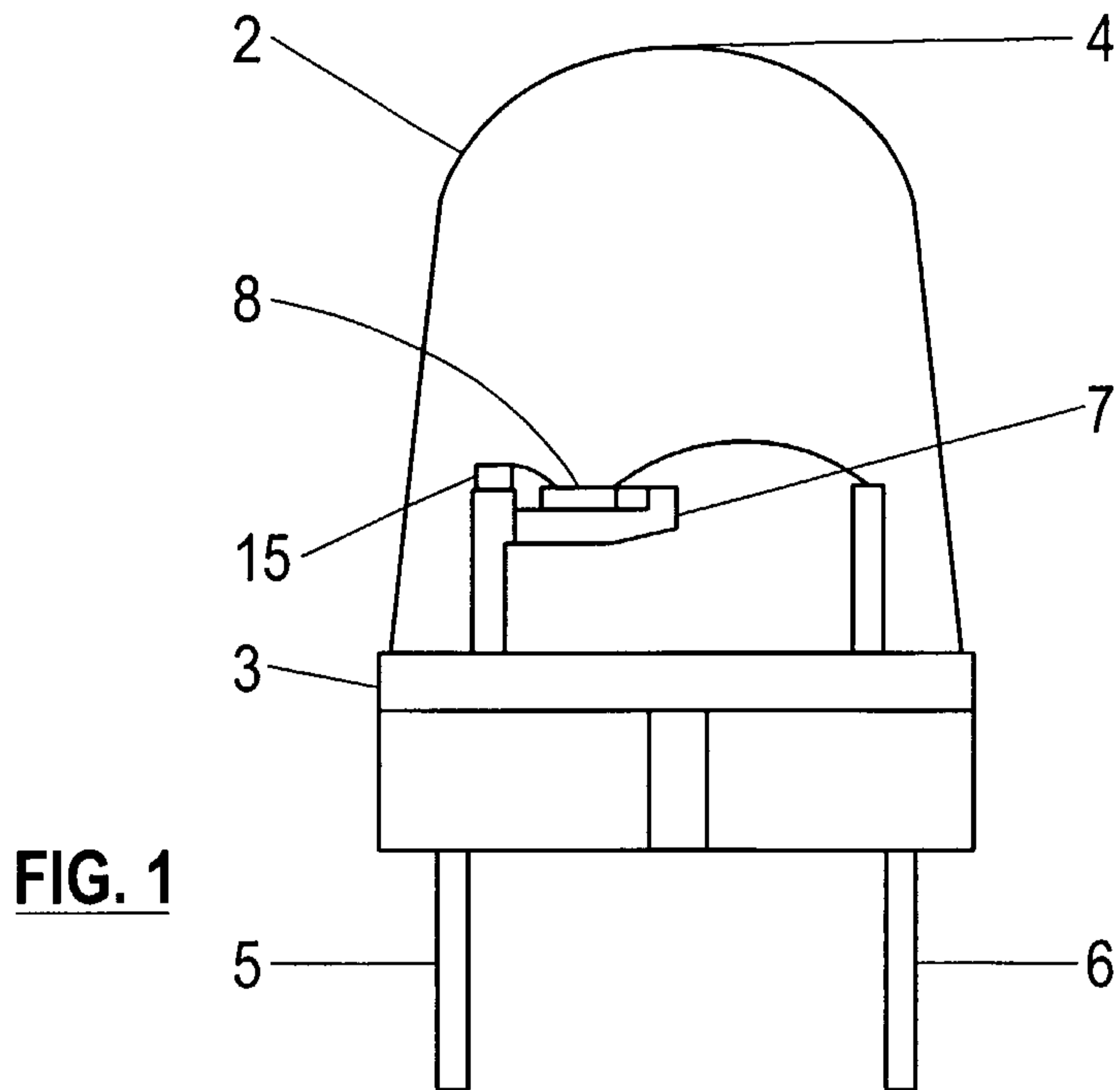

FIG. 7

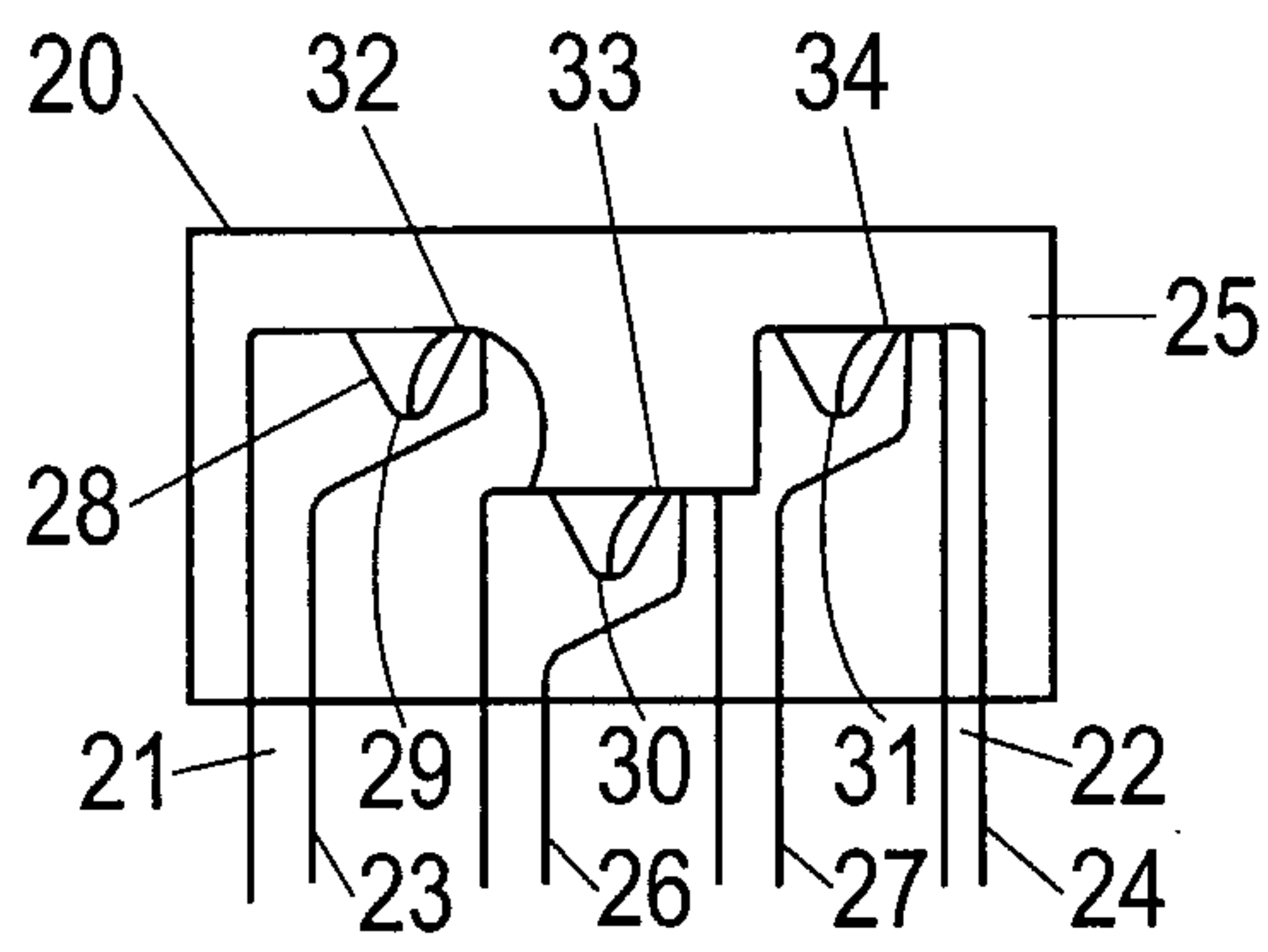
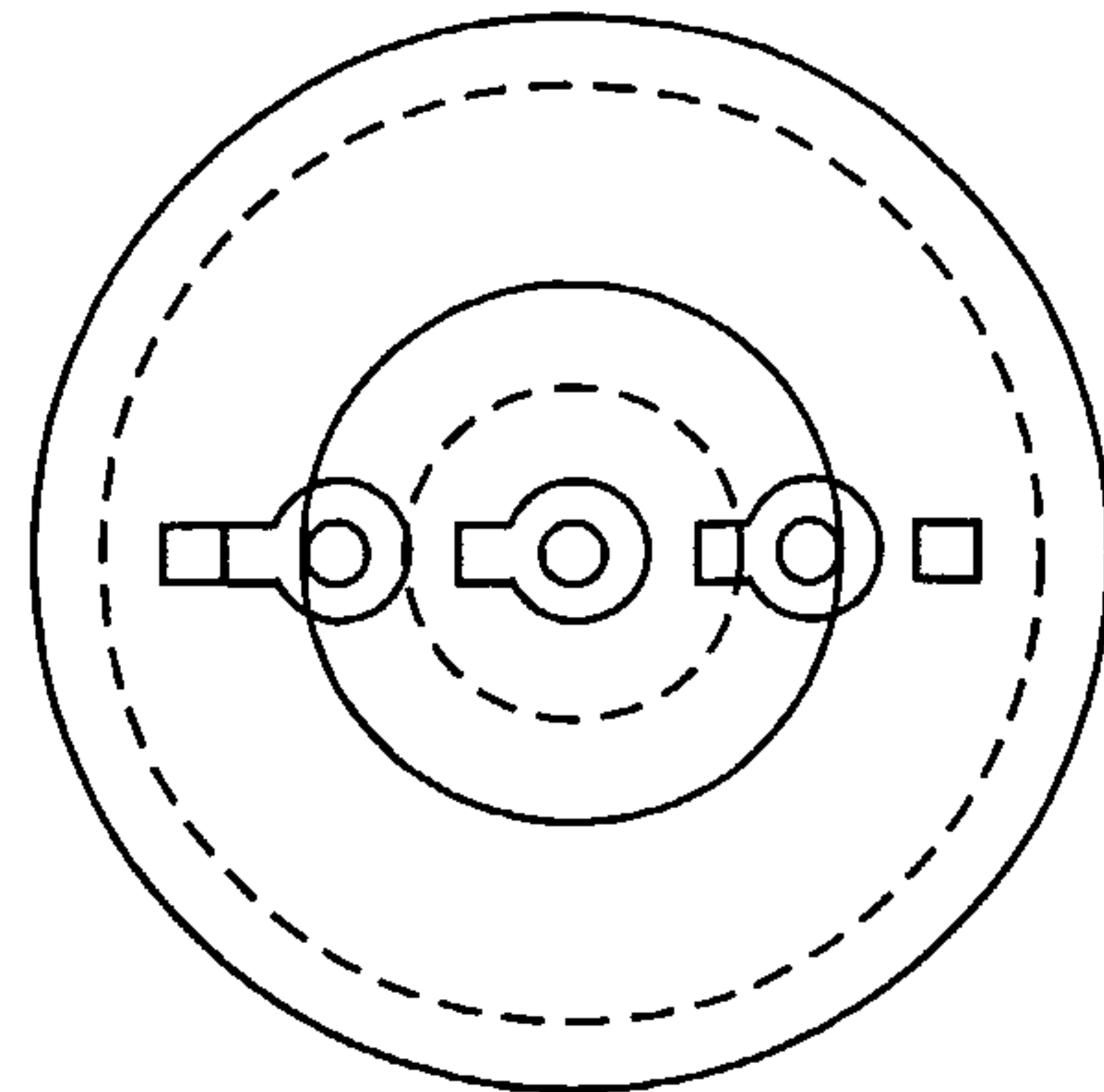

FIG. 4

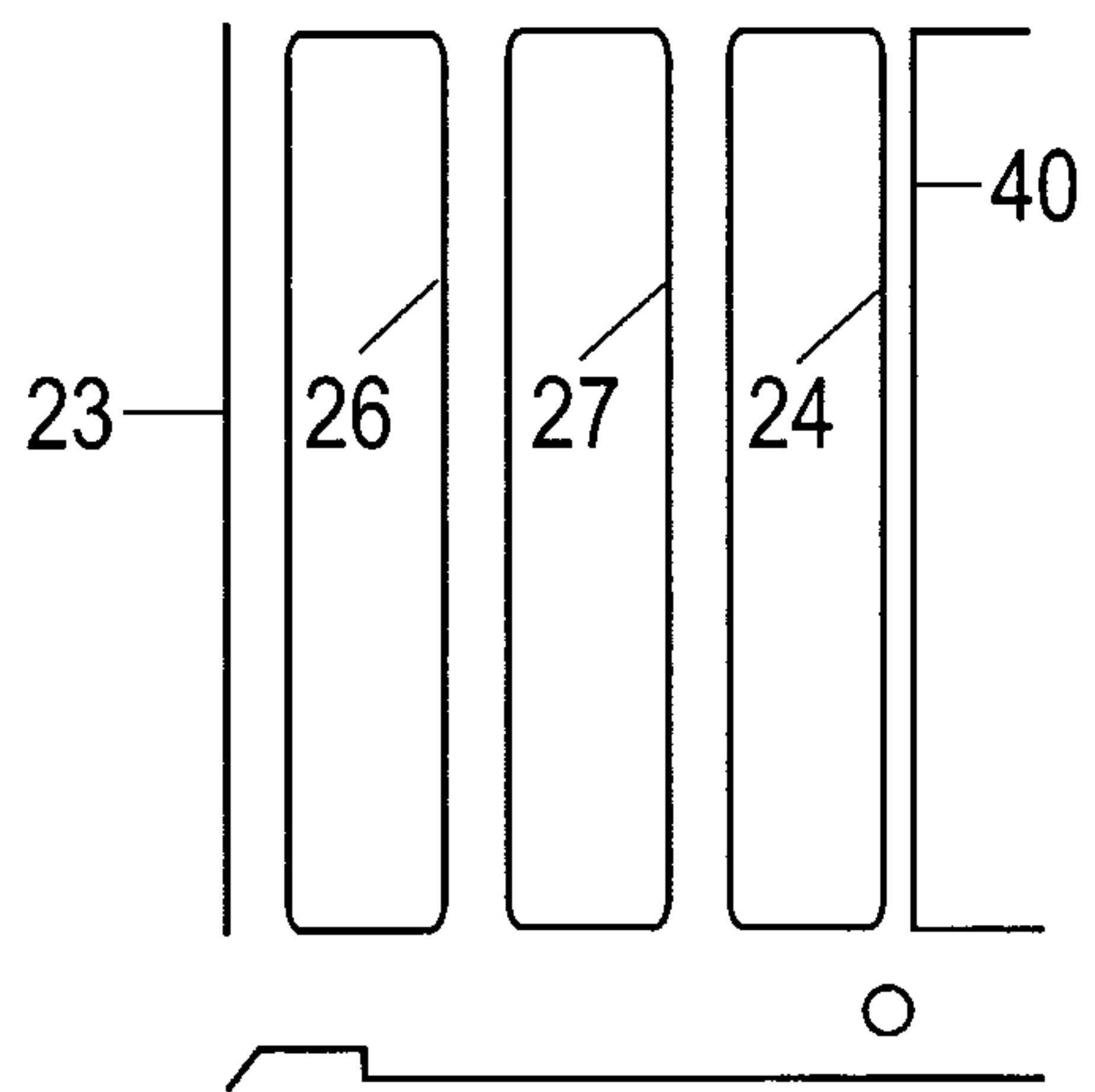
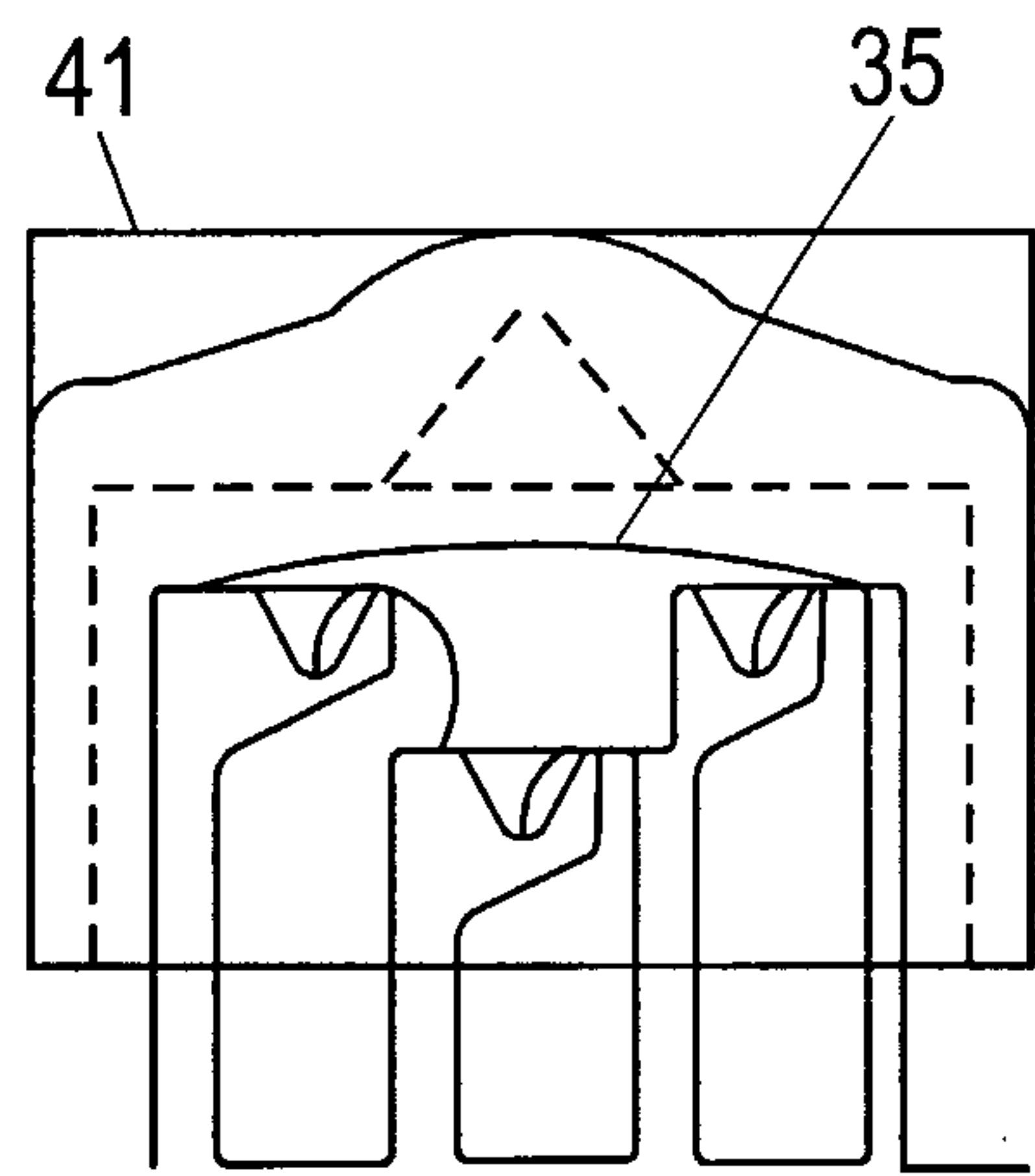

FIG. 6

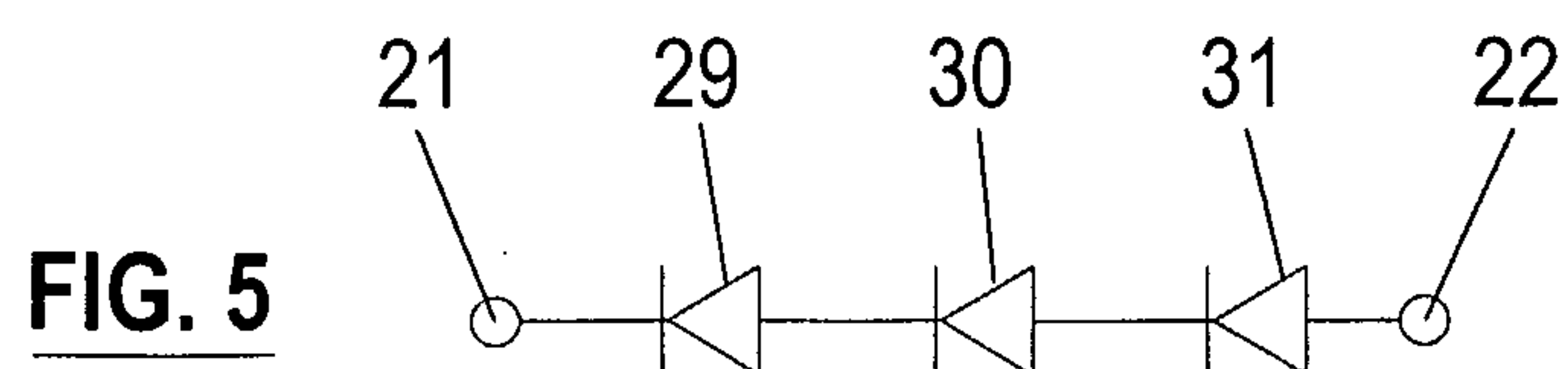

FIG. 5

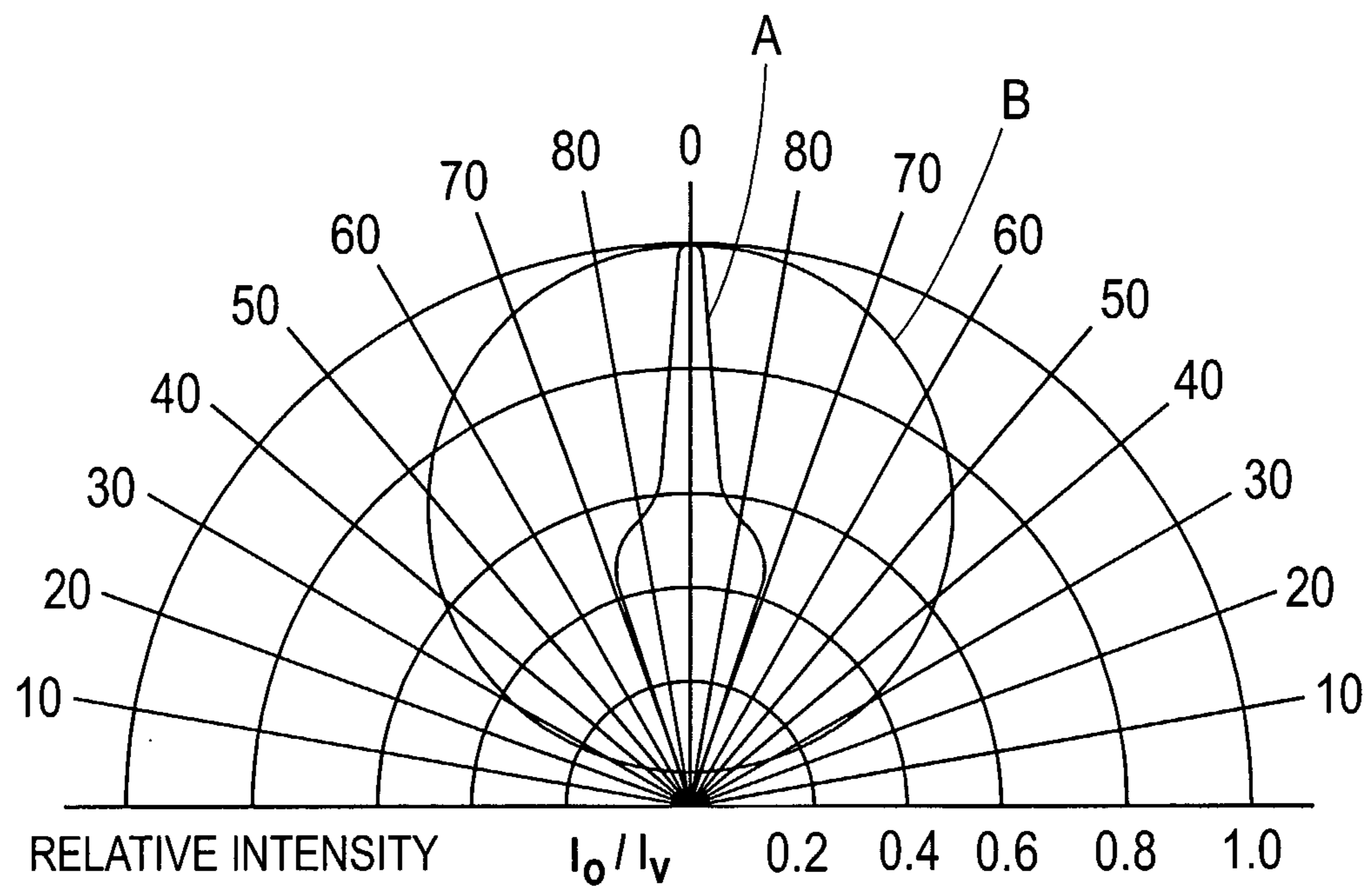
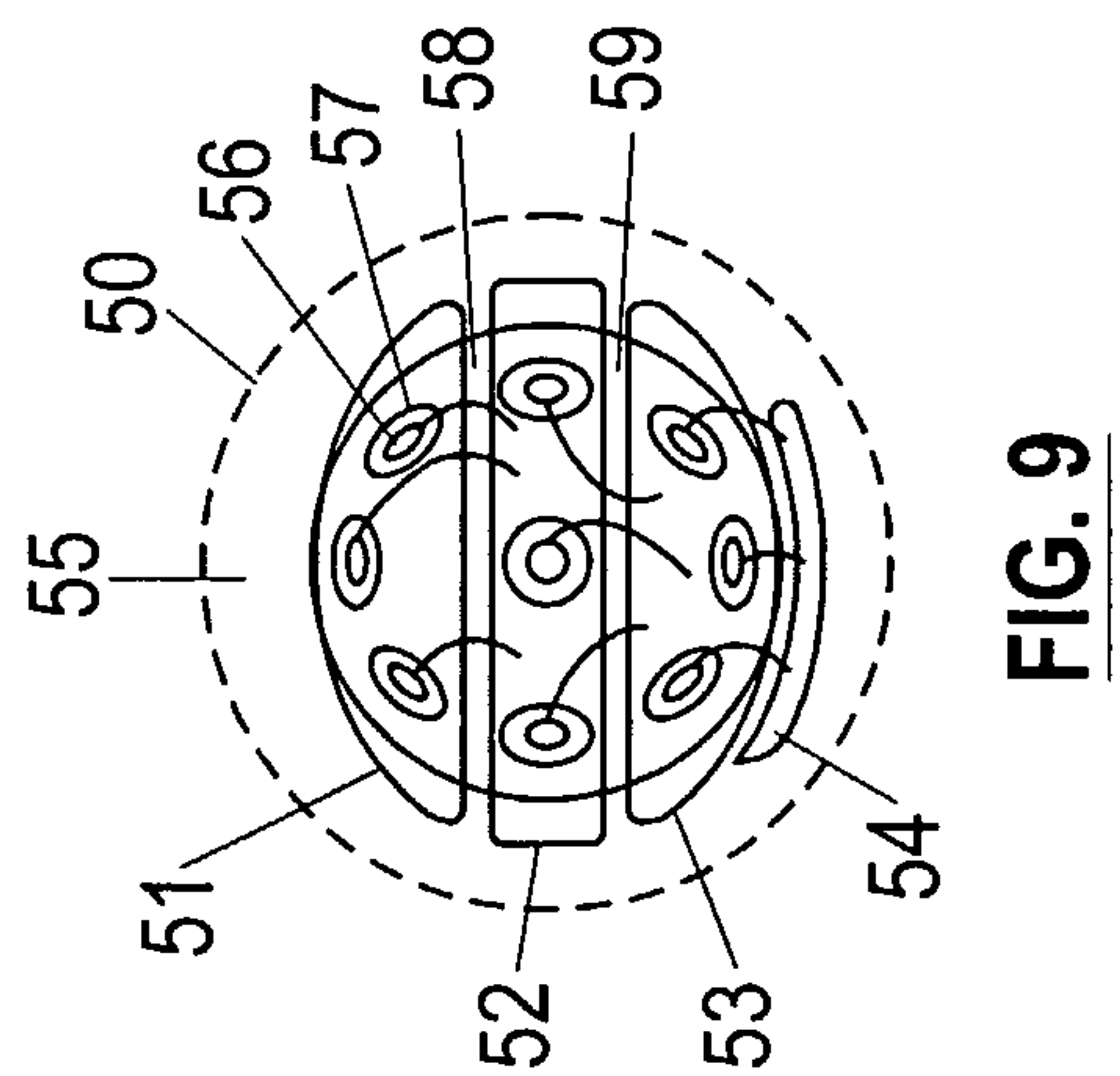
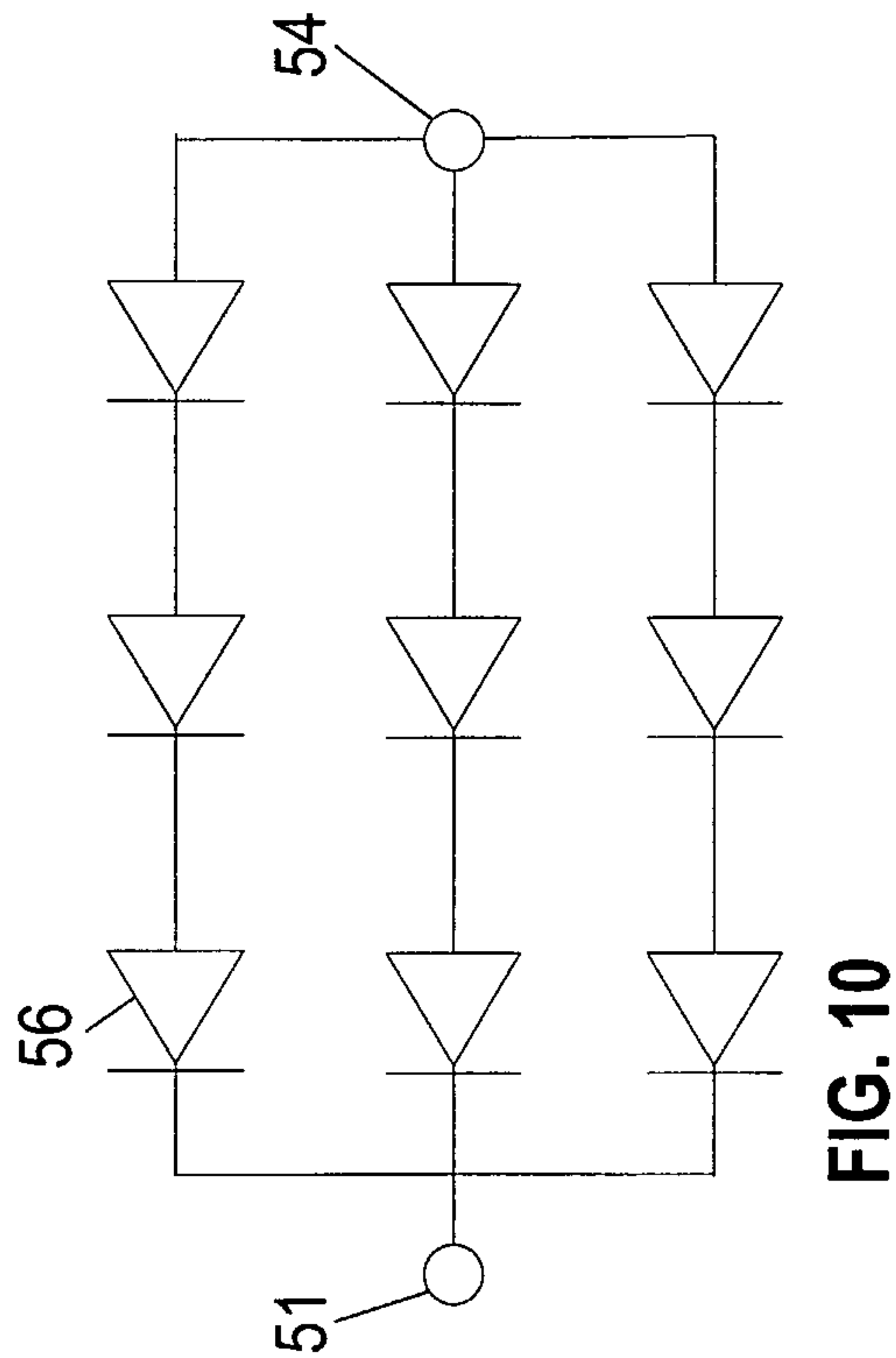
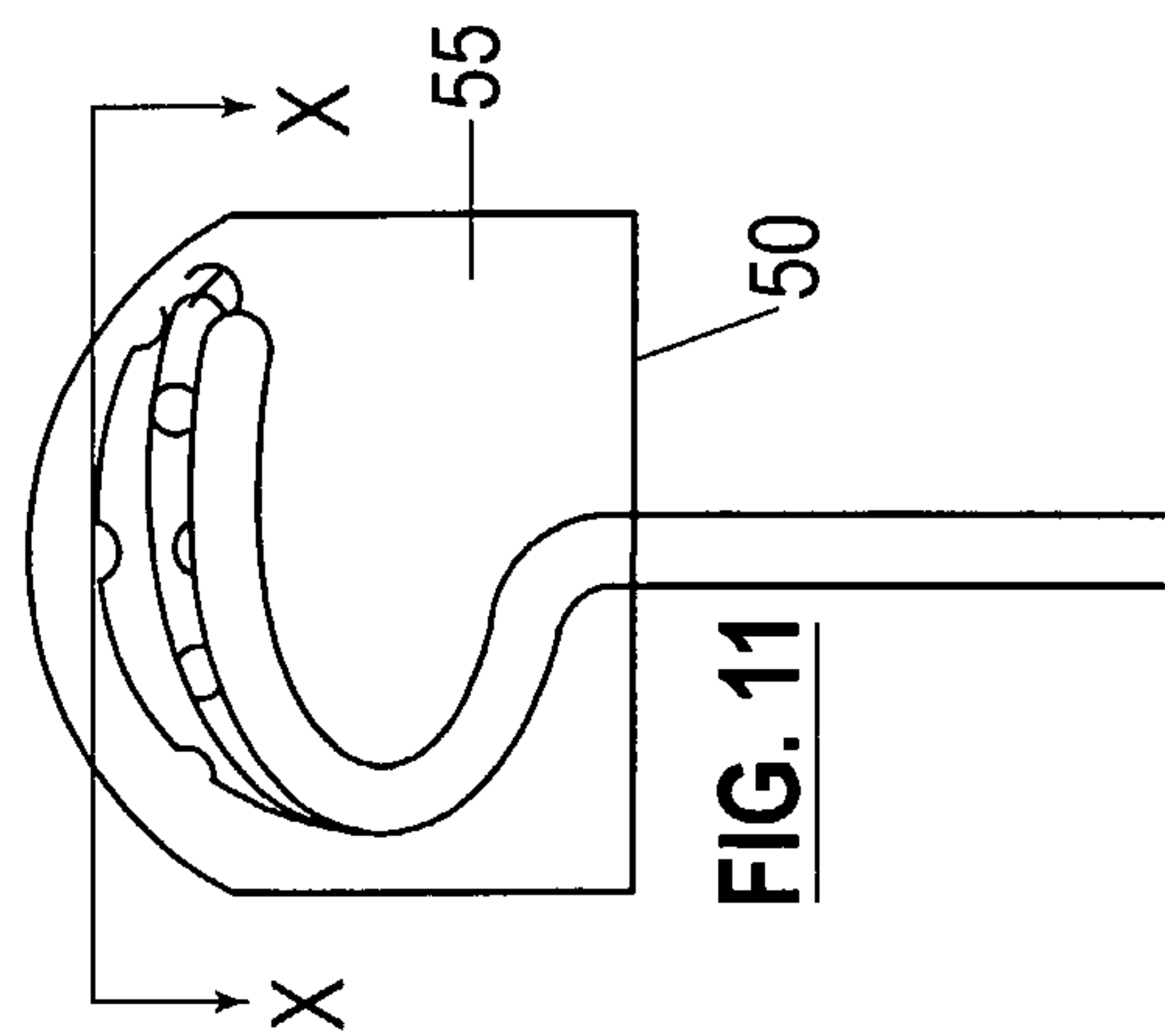
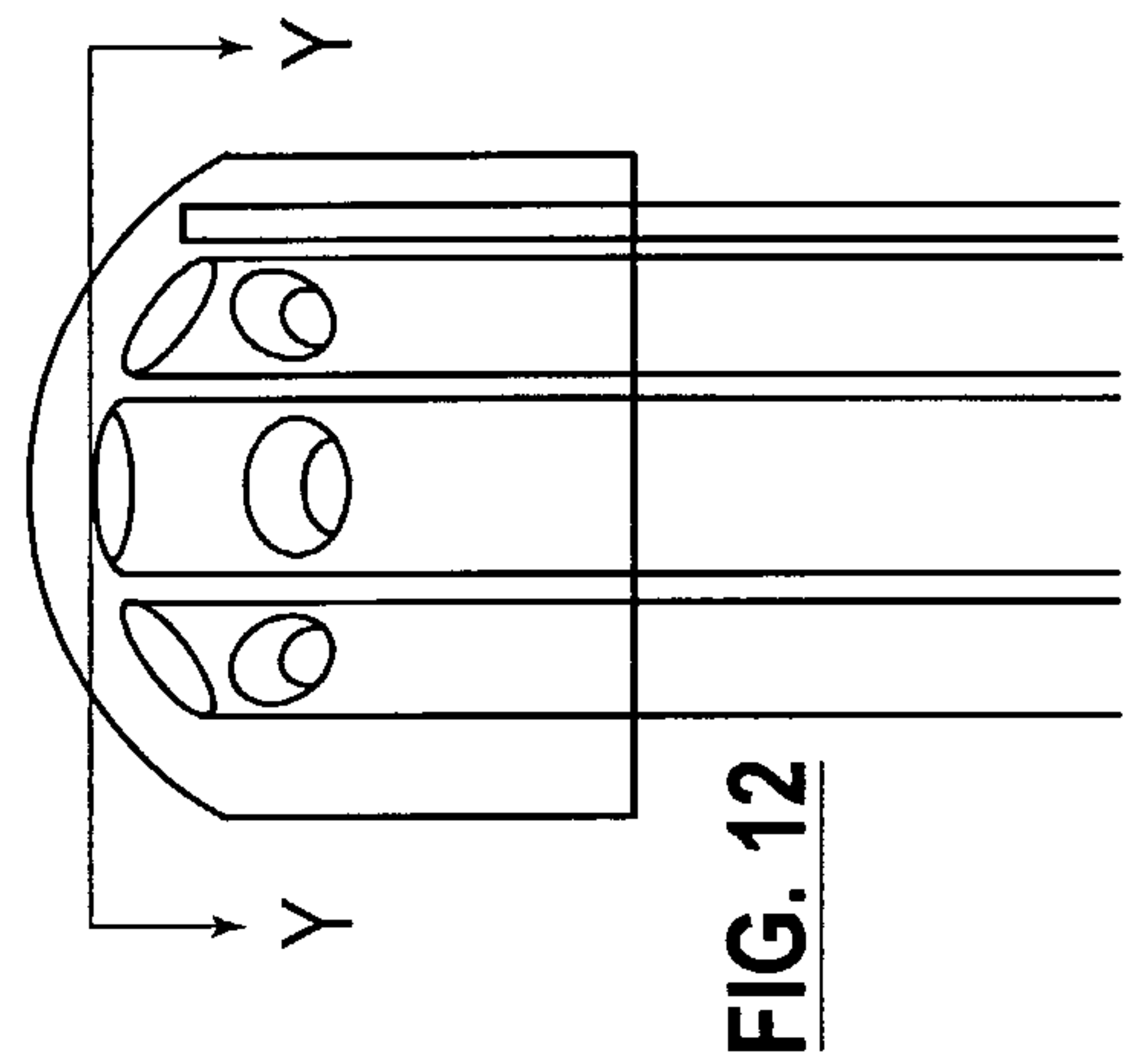
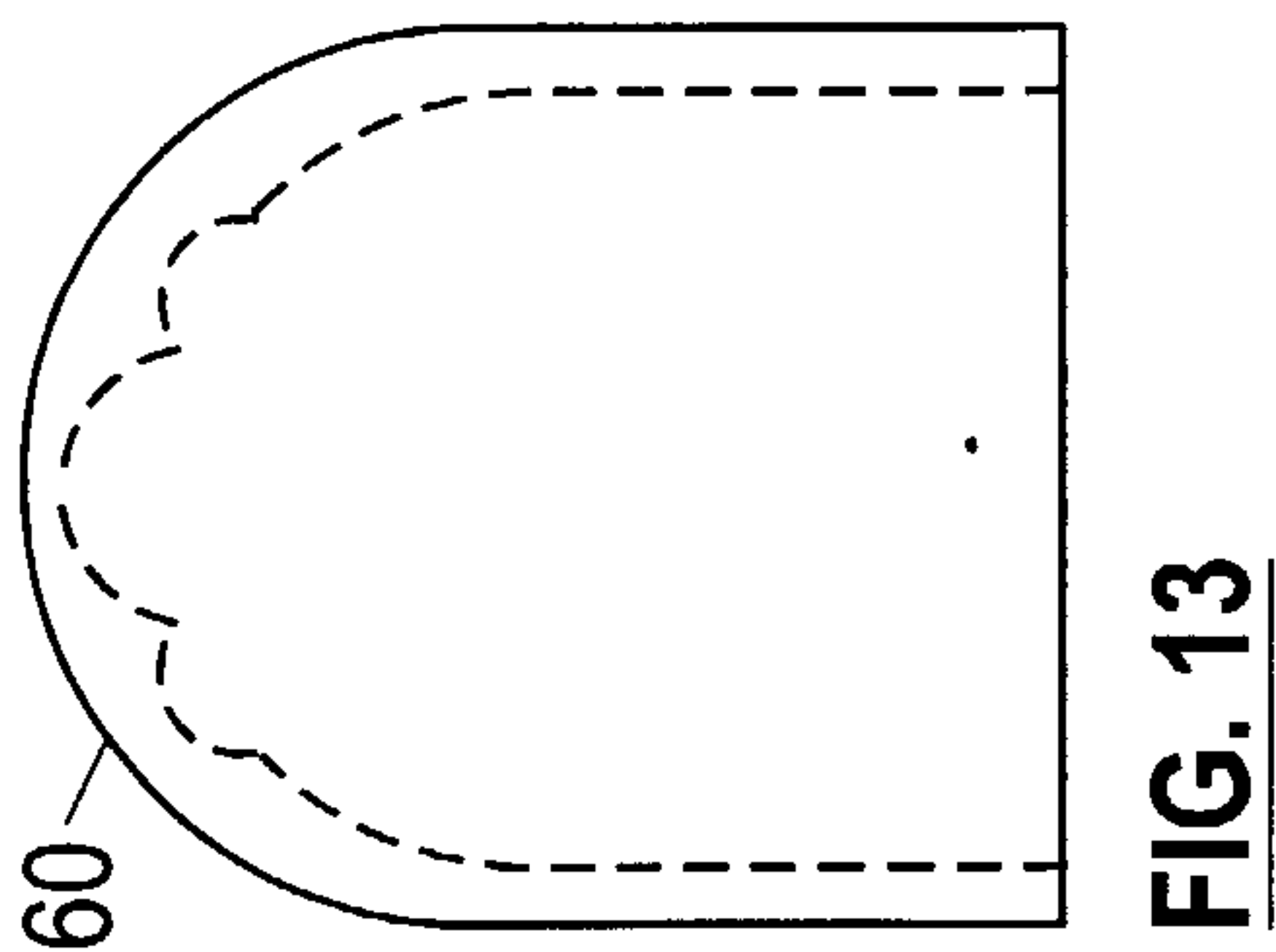

FIG. 8



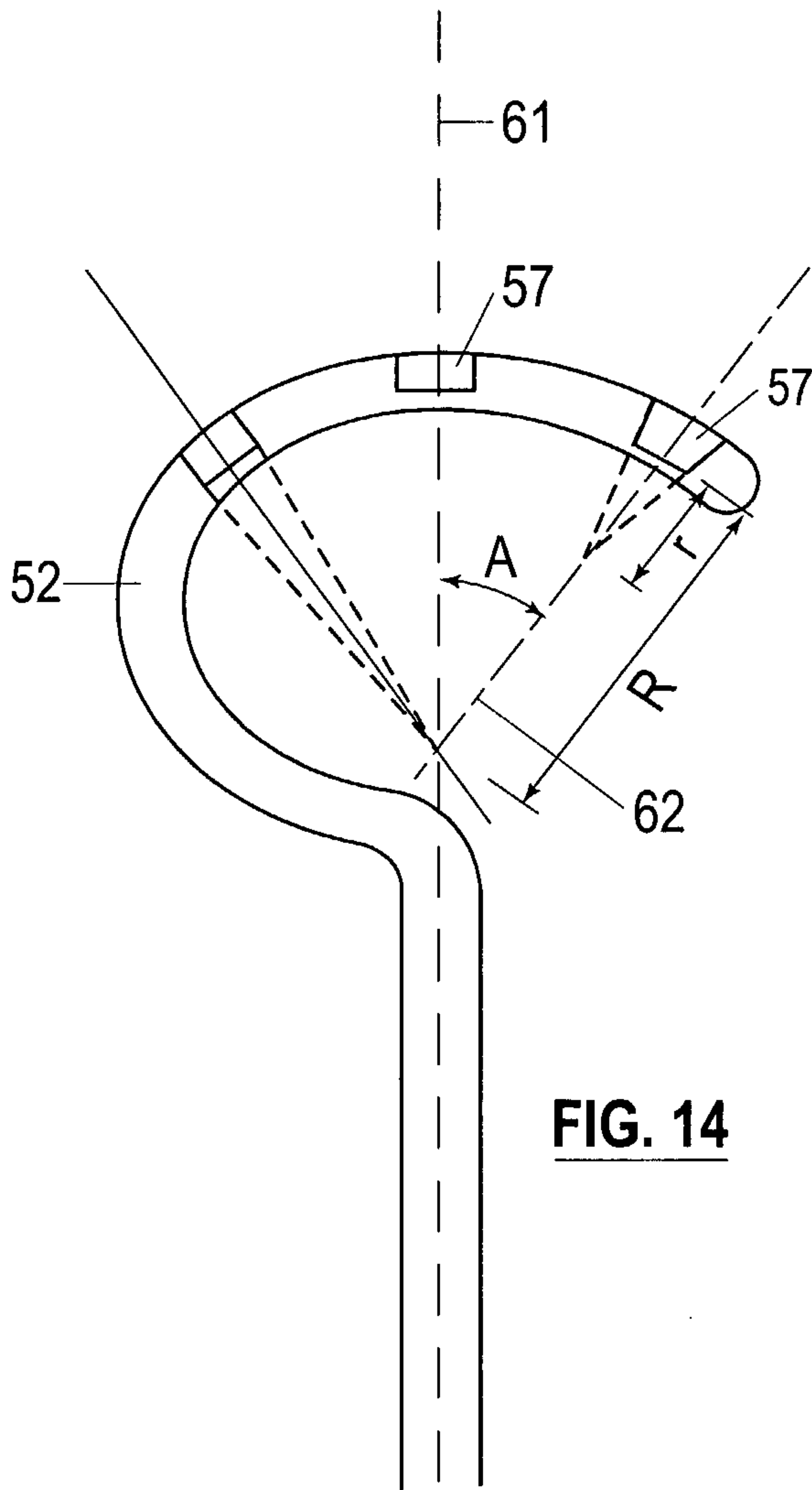

FIG. 14

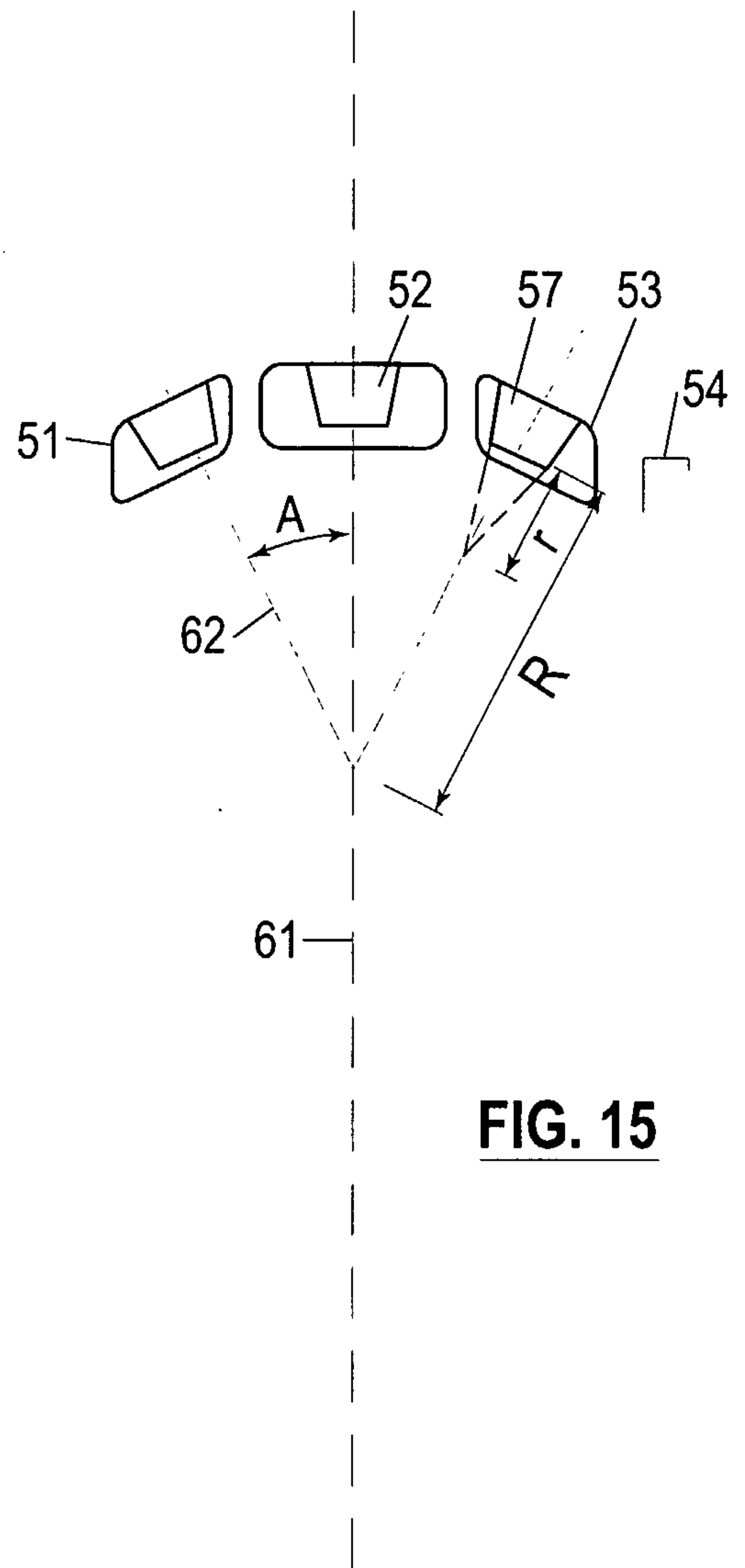

FIG. 15

6 / 15

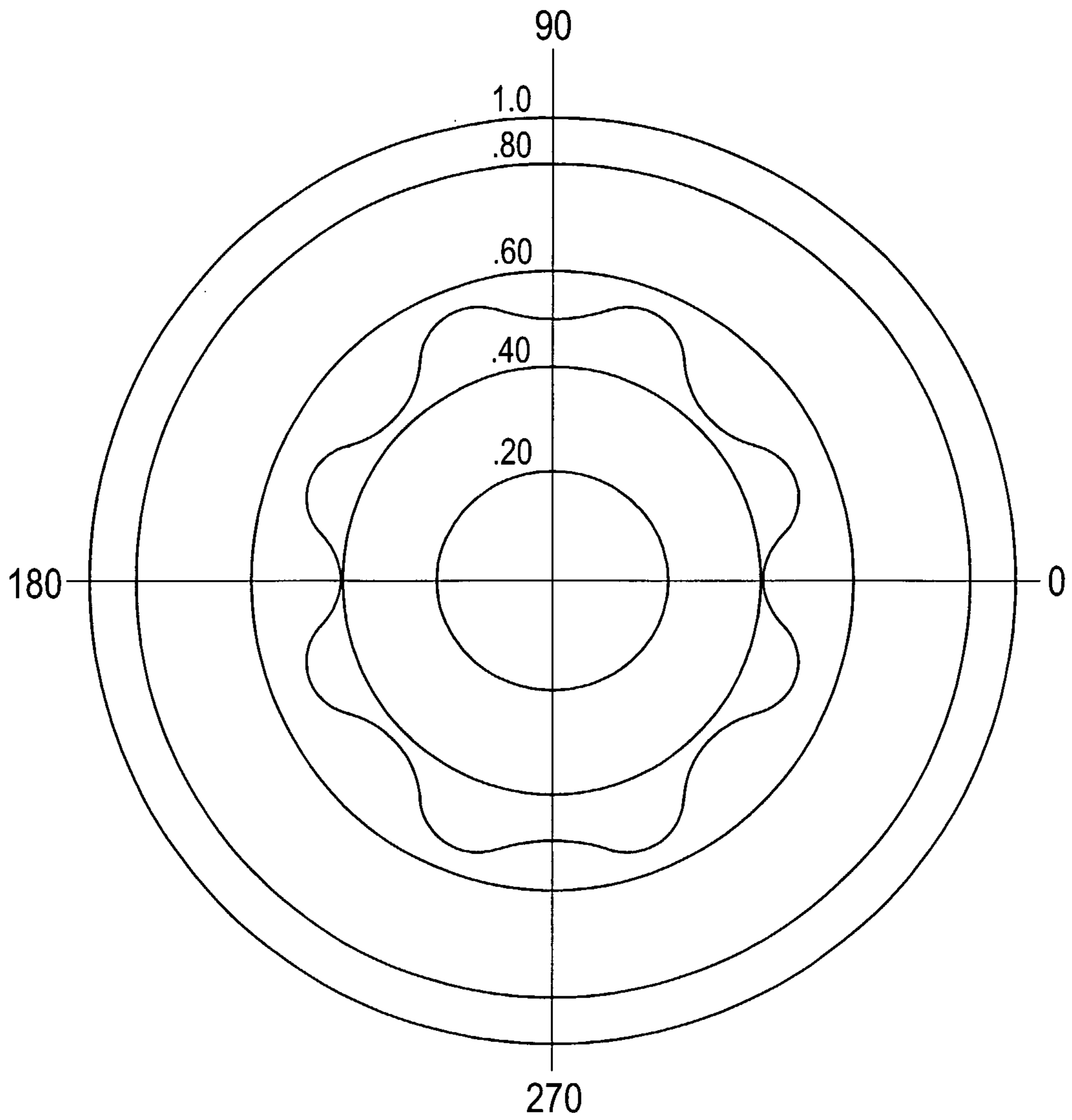

FIG. 16

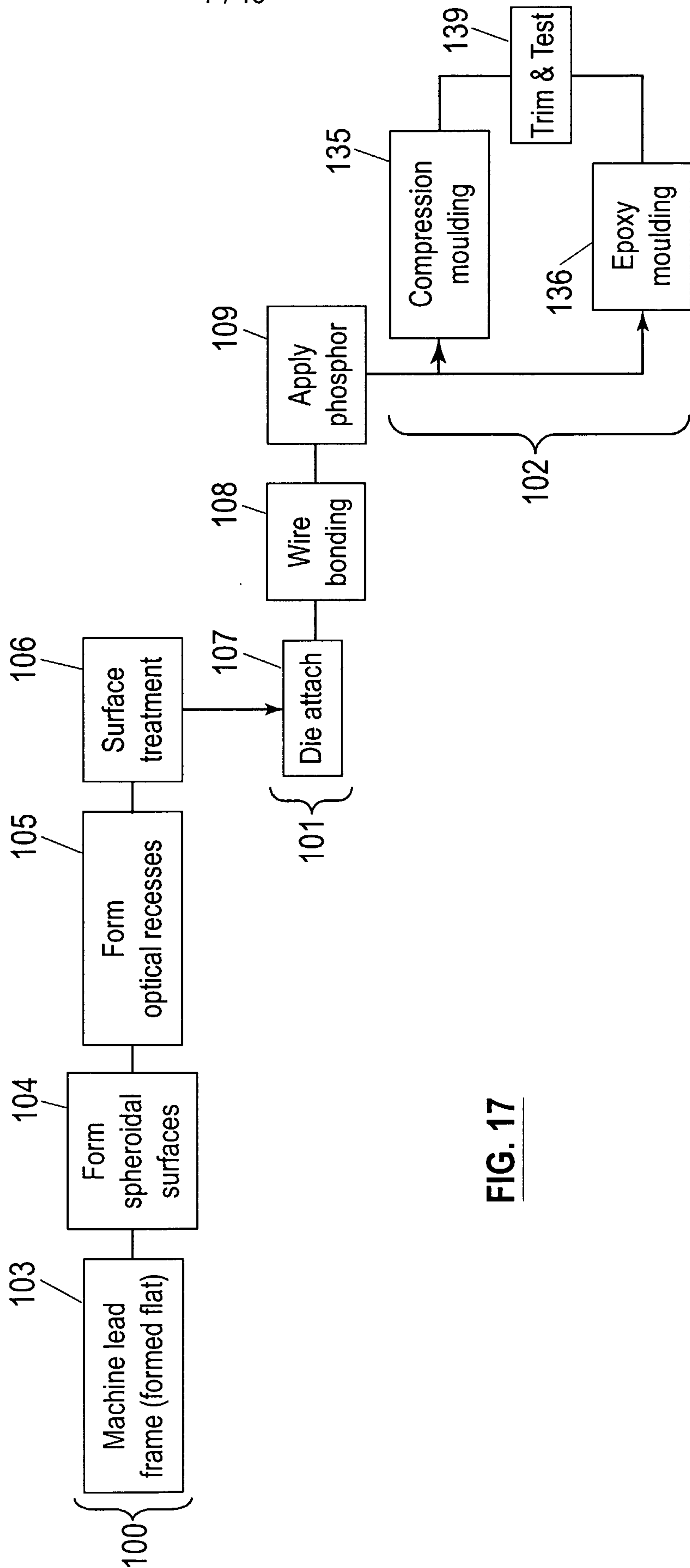
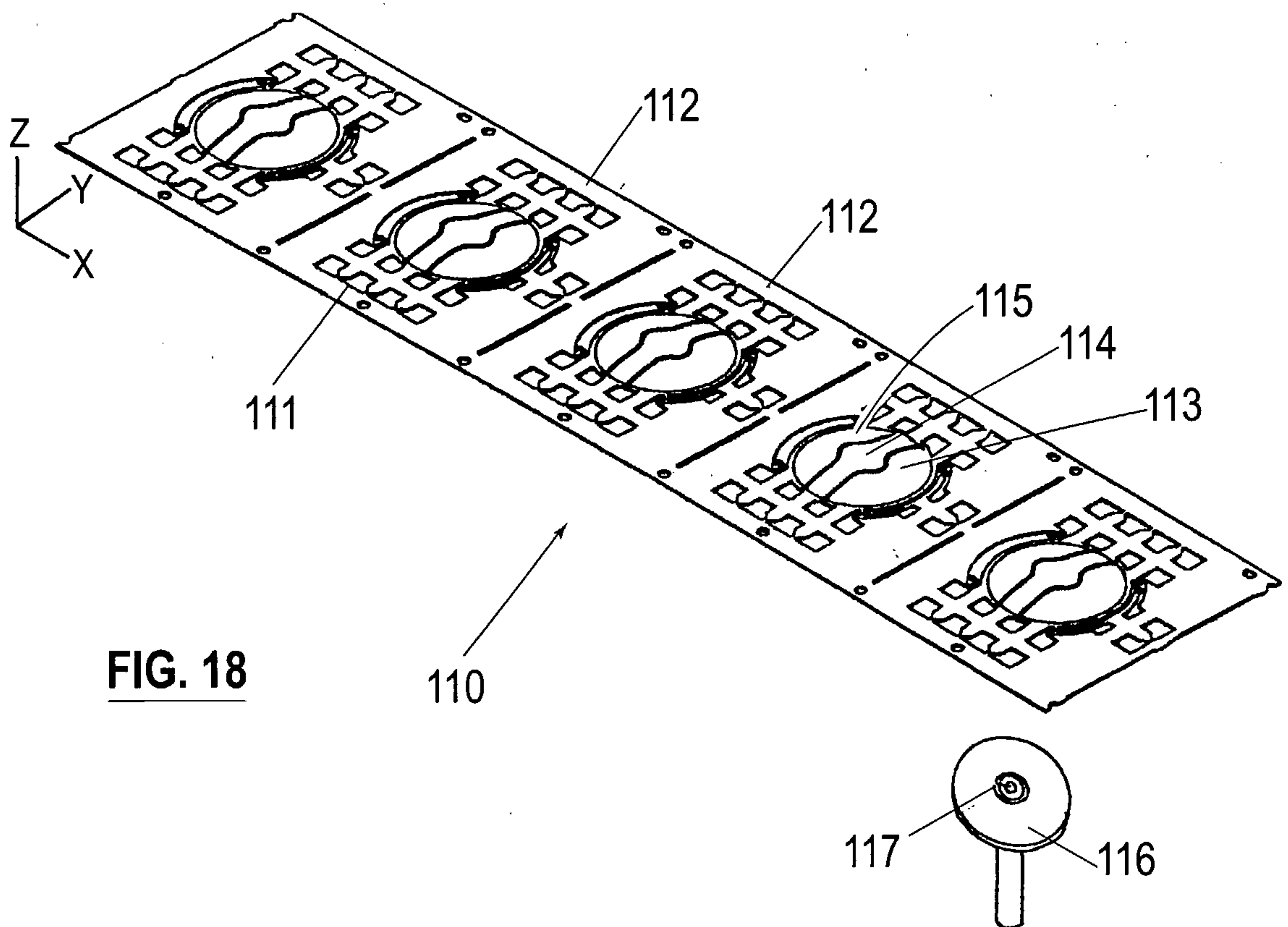

FIG. 17



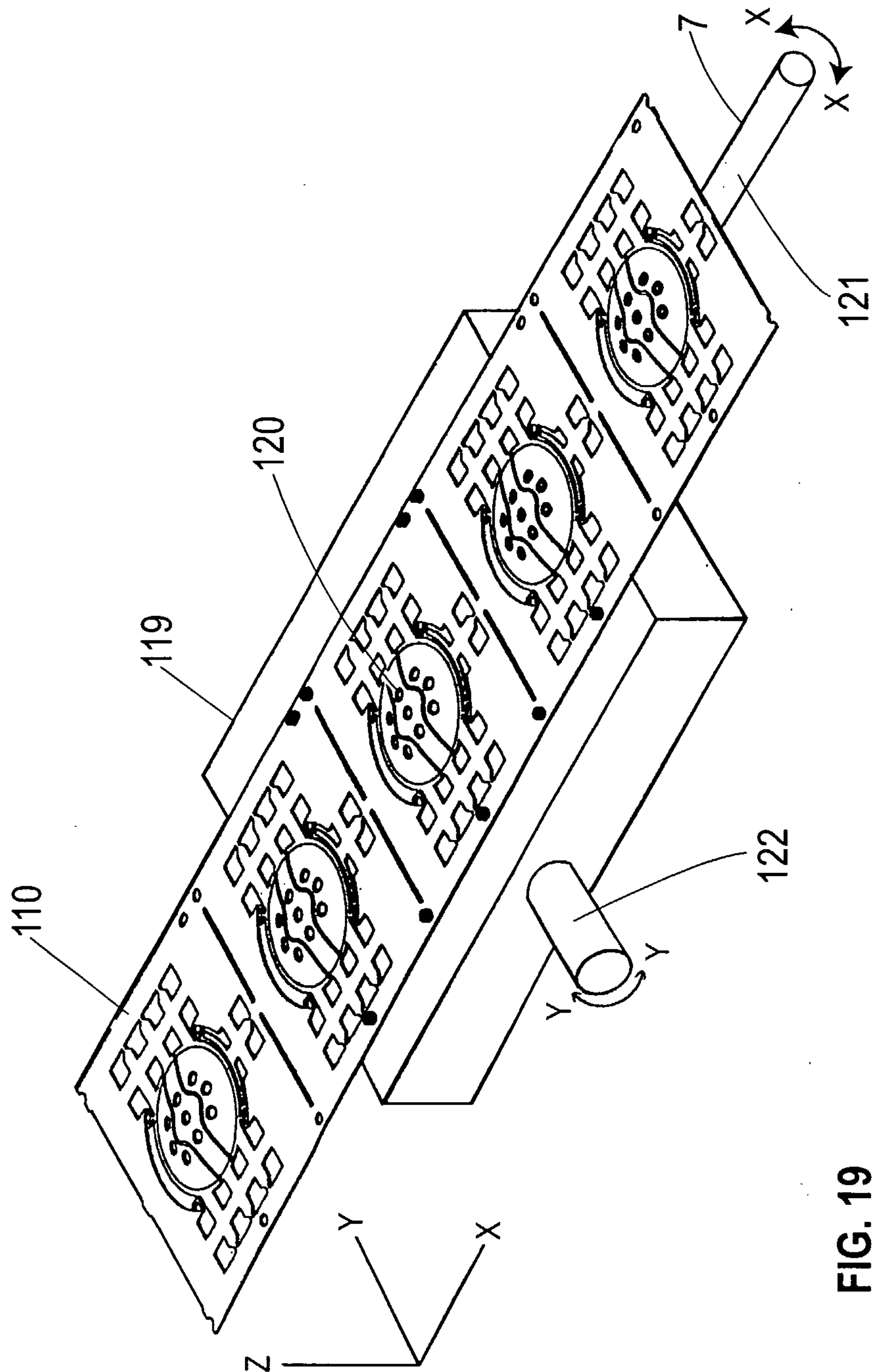

FIG. 19

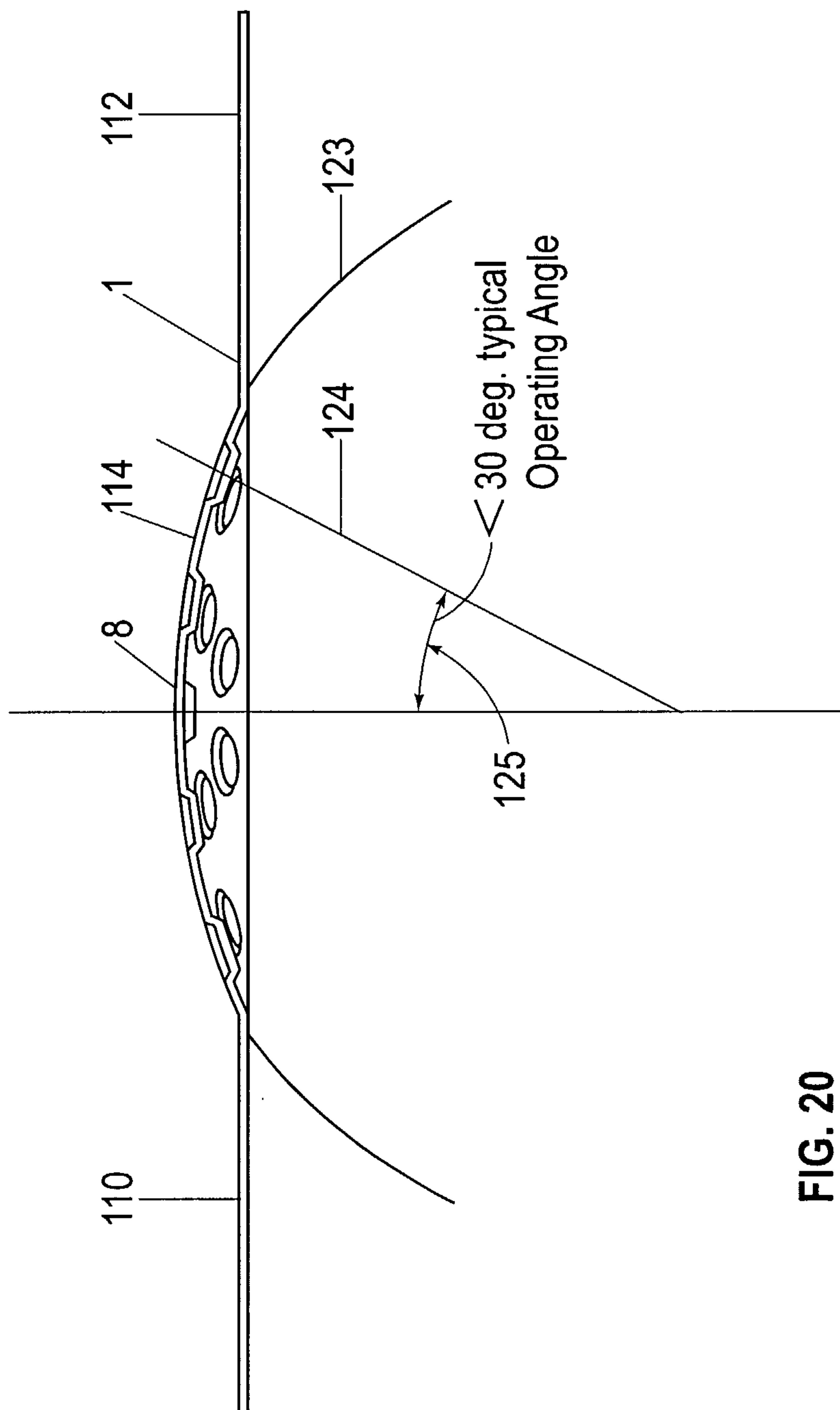

FIG. 20

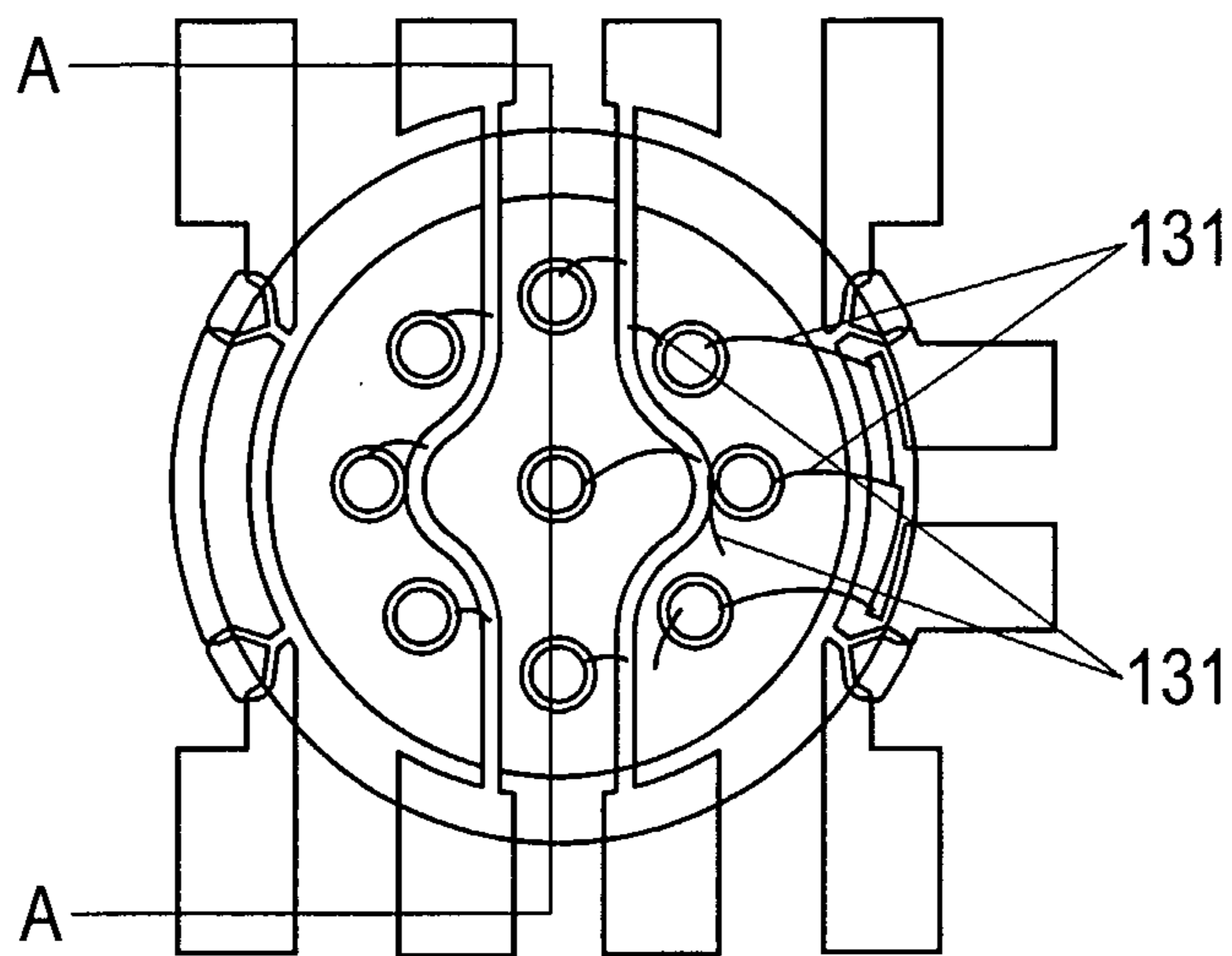

FIG. 21a

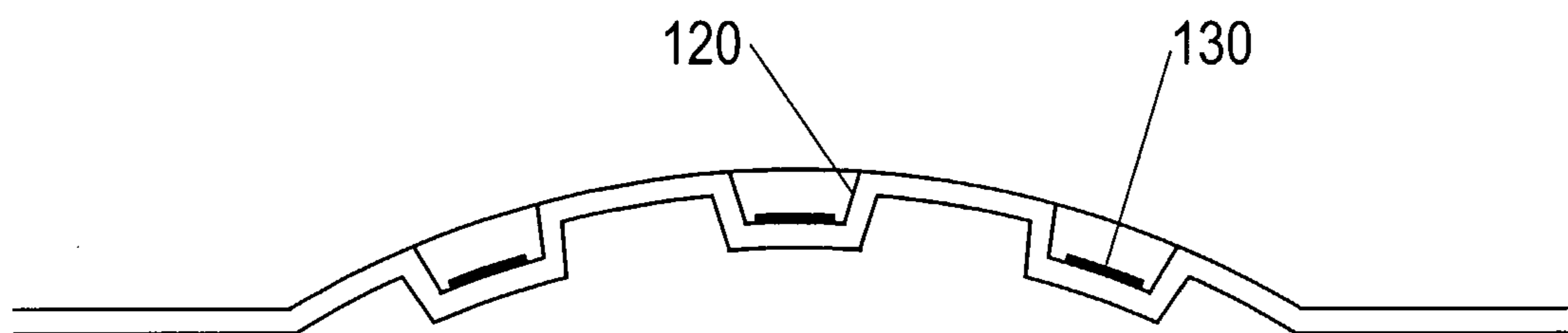

FIG. 21b

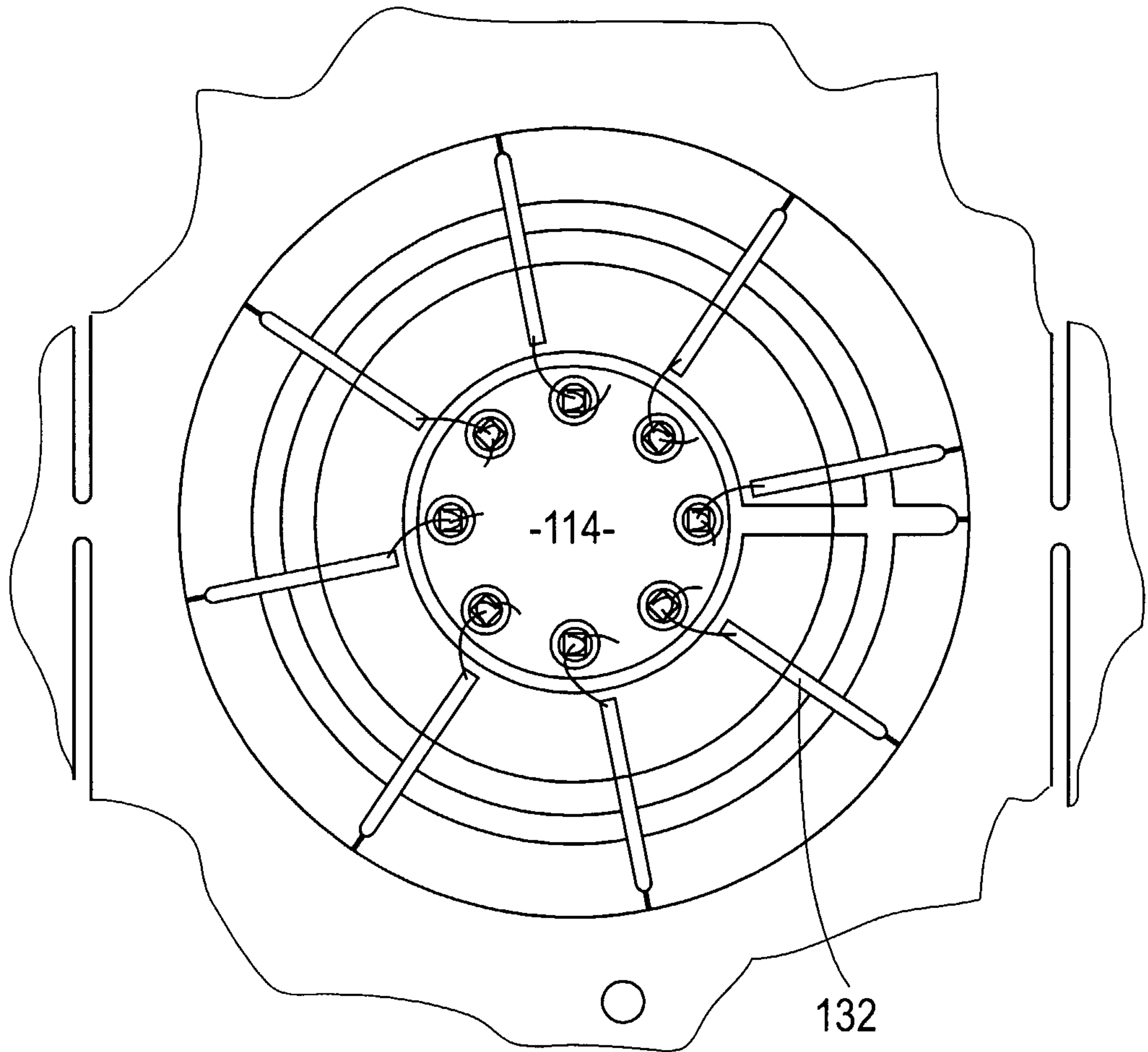

FIG. 22

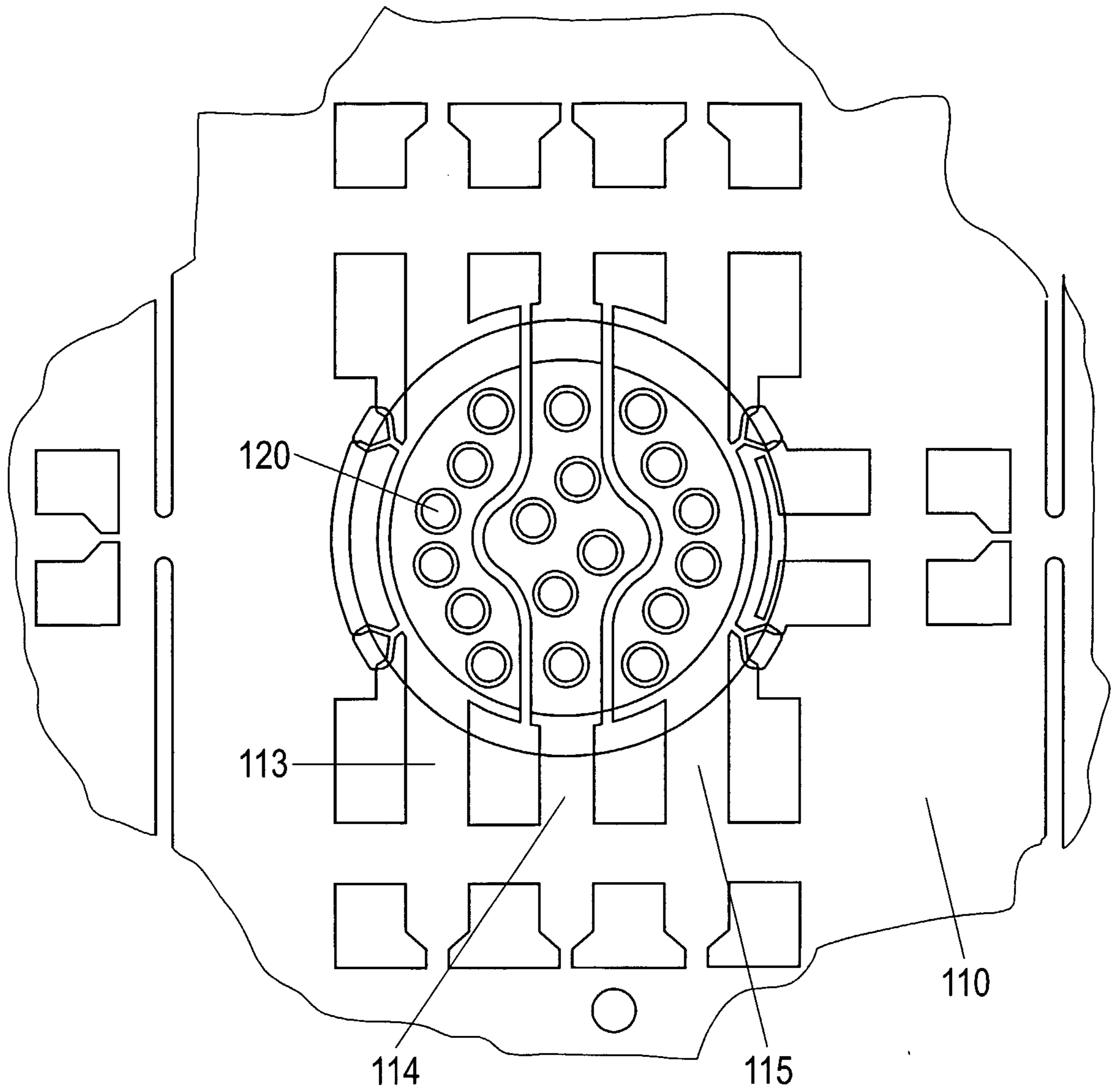

FIG. 23

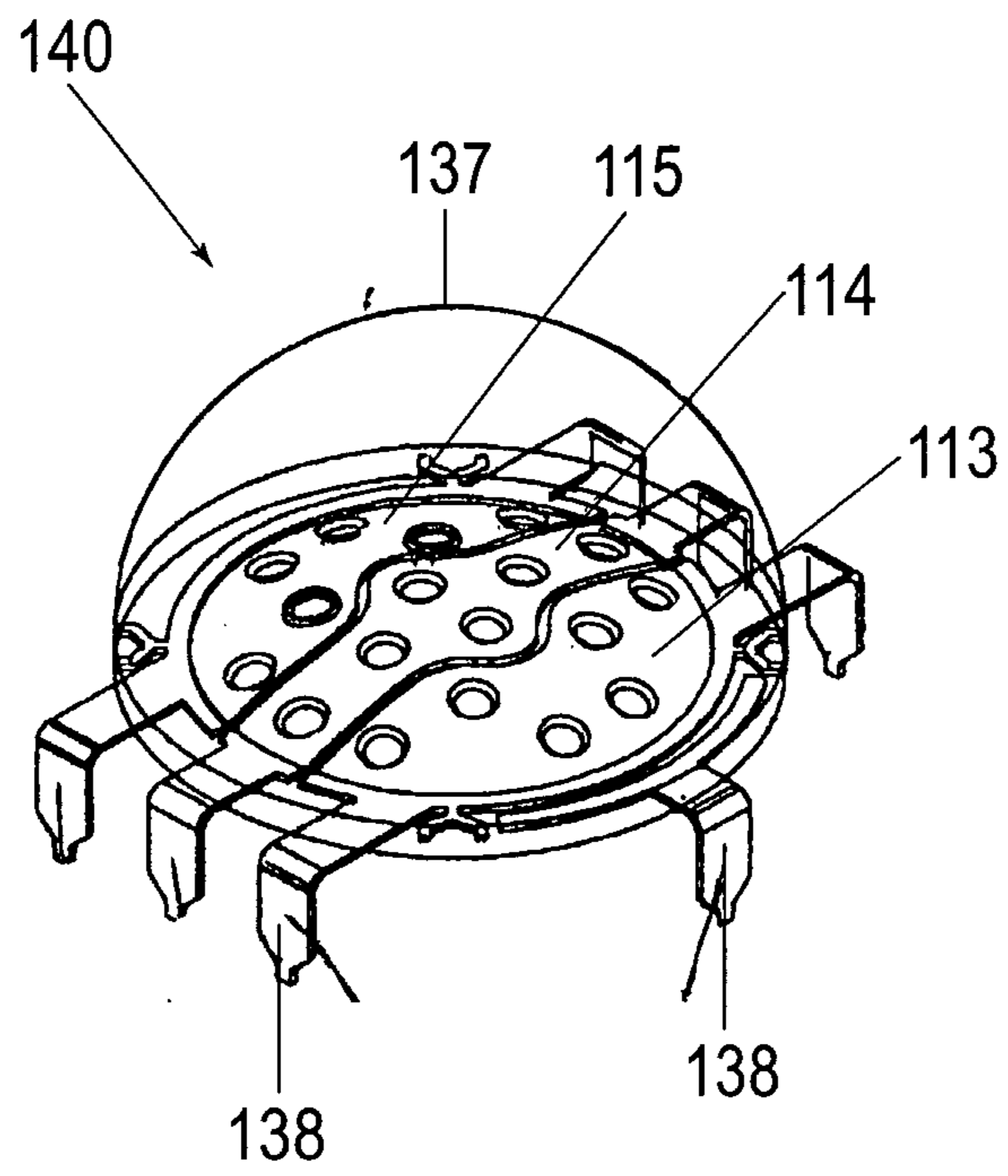

FIG. 24

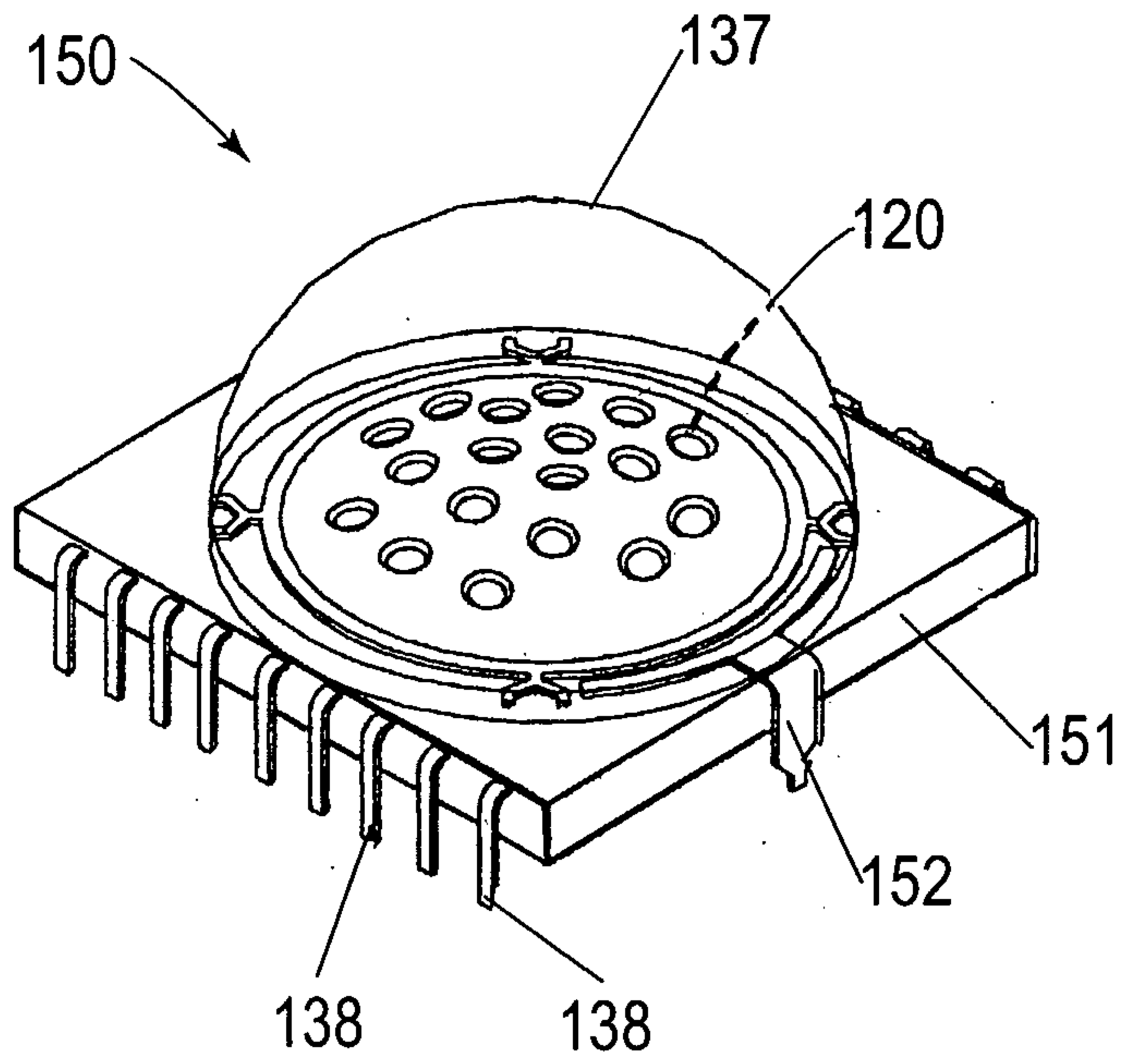

FIG. 25

