

DELOY F. SUTTON & BERNARD MEILINK.

Improvement in Tonguing and Grooving Machines.

No. 119,896.

Patented Oct. 10, 1871.

Fig. 1.

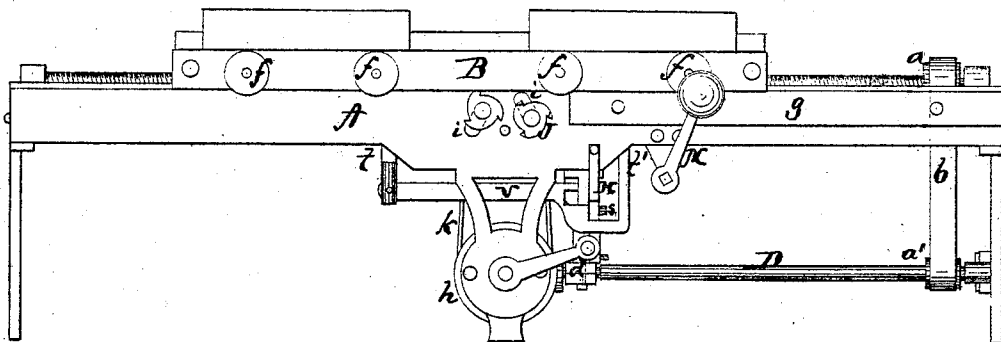
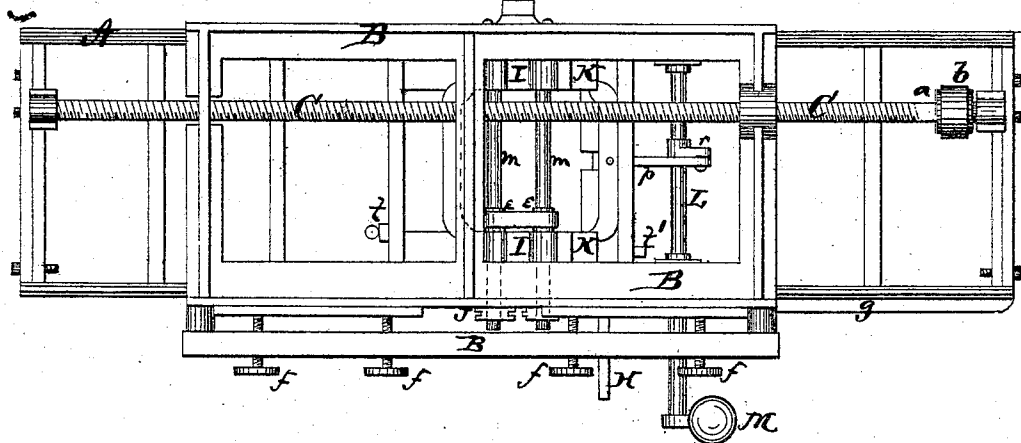

Fig. 2.



Witnesses:

Henry N. Miller
Le. L. Evers

Inventor

Deloy F. Sutton,
Bernard Meilink
per Alexander Mason
attys.

DELOY F. SUTTON & BERNARD MEILINK.
Improvement in Tonguing and Grooving Machines.
No. 119,896. Patented Oct. 10, 1871.

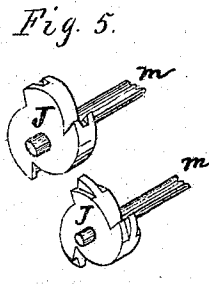
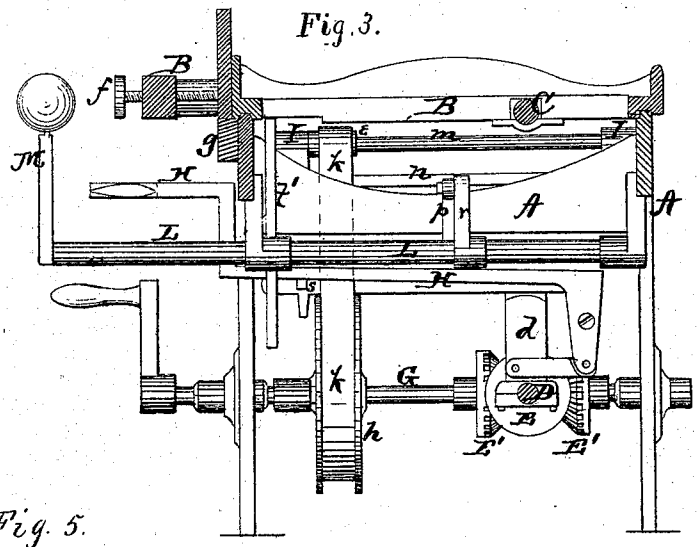

Fig. 4.

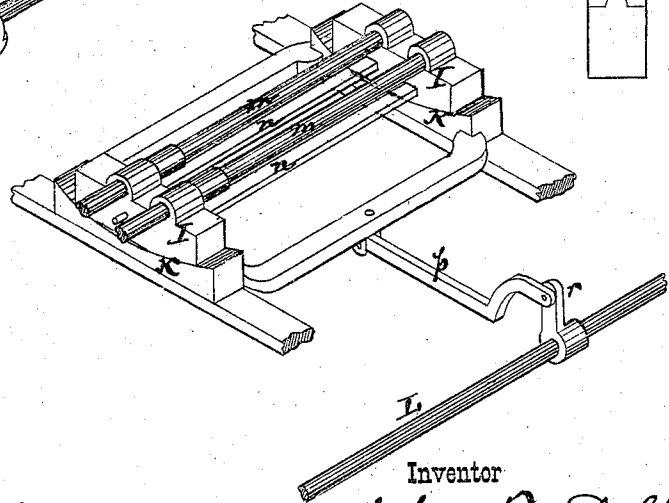

Fig. 6.



Witnesses:
Henry N. Miller
C. L. Ewert

Inventor
Deloy F. Sutton.
Bernard Meilink
per Alexander Massey
attor-

UNITED STATES PATENT OFFICE.

DELOY F. SUTTON AND BERNARD MEILINK, OF TOLEDO, OHIO; SAID SUTTON
ASSIGNOR TO N. WATERMAN, OF SAME PLACE.

IMPROVEMENT IN TONGUING-AND-GROOVING MACHINES.

Specification forming part of Letters Patent No. 119,896, dated October 10, 1871.

To all whom it may concern:

Be it known that we, DELOY F. SUTTON and BERNARD MEILINK, of Toledo, in the county of Lucas and in the State of Ohio, have invented certain new and useful Improvements in Jointing-Machines; and do hereby declare that the following is a full, clear, and exact description thereof, reference being had to the accompanying drawing and to the letters of reference marked thereon making a part of this specification.

The nature of our invention consists in the construction and arrangement of a tonguing-and-grooving machine, as will be hereinafter more fully set forth.

In order to enable others skilled in the art to which our invention appertains to make and use the same, we will now proceed to describe its construction and operation, referring to the annexed drawing, in which—

Figure 1 is a side elevation; Fig 2, a plan view; and Fig. 3, a transverse vertical section of our machine. Fig. 4 is an enlarged perspective view of the mechanism whereby the cutter-heads are changed alternately; Fig. 5 shows the cutter-heads; and Fig. 6 shows two pieces of wood as joined together.

A represents the stationary bed or frame of our machine, upon which is moved back and forth the carriage B by means of the screw C. This screw is provided at one end with a pulley, *a*, which is, by a belt, *b*, connected with a pulley, *a'*, on a shaft, D, situated in the lower part of the frame A. The outer end of this shaft has a stationary bearing, while the inner end has its bearing in a bar, *d*, which is pivoted at its upper end and may be swung from side to side, by means that will be hereinafter described, to cause the shaft to revolve in either direction and consequently feed the carriage either backward or forward. Upon the inner end of the shaft D is a bevel-wheel, E, which, by the motion of the bearing-bar *d*, is made to gear with either one of two bevel-wheels, E', upon the main driving-shaft G. The wheels E E' may be either cog or friction-wheels, as may be desired. The bearing-bar *d* is by a short bar or rod connected with an angular lever, H, whereby the wheel E is made to engage with either of the wheels E', for the purpose already mentioned. The lumber to be operated upon is held in the carriage B by set-screws *f f*, and the depth of the cut is regulated

by raising and lowering the guide *g* on the side of the main frame. The boards are then dropped in and fastened by the set-screws. From a large pulley, *h*, upon the main driving-shaft G, a belt, *k*, passes around pulleys *e e* upon two parallel shafts, *m m*, which have their bearings in two oscillating heads, I I, connected by cross-bars *n n* and pivoted in the sides of the main frame A. On one side the ends of the shafts *m m* pass through slots *i i* in the side of the main frame, and upon said ends of the shafts are secured the cutter-heads J J. These cutter-heads are constructed as shown in Fig. 5, one to cut the tongue and the other to cut the groove. The heads are made of solid steel, each with two or more cutters, which are beveled or inclined so as to form a bevel-joint, as shown in Fig. 6. Under the oscillating heads I I is placed a double wedge-shaped slide, K, connected by a rod, *p*, with an arm, *r*, on a shaft, L, said shaft being at one end provided with a lever, M, by means of which the slide K is moved to and fro.

It will be noticed that the motion of the slide K causes the heads I I to oscillate, and thus bring either one of the cutter-heads J J in contact with the lumber at the option of the operator. The lever H, which regulates the feed, is held either above or below a lug, *s*, seen in Fig. 1, according to the direction of the feed, and as soon as the carriage B has moved far enough in either direction so as to bring the lumber beyond the cutter-heads the carriage strikes a post, *t* or *t'*, connected with a slide, *v*, which releases the lever H from the lug *s* and thereby causes the feed to stop. After the boards have been cut they are joined together in the usual manner. The joint being bevel makes it far stronger than the ordinary straight tongue-and-groove joint.

Having thus fully described our invention, what we claim as new, and desire to secure by Letters Patent, is—

1. The oscillating heads I I carrying the parallel shafts *m m*, upon which the male and female cutter-heads are placed, substantially as and for the purposes herein set forth.

2. The combination of the oscillating heads I I, shafts *m m*, cutter-heads J J, and double wedge-shaped slide K, all substantially as and for the purposes herein set forth.

3. The combination, with the double wedge-shaped slide K, of the connecting-rod *p*, arm *r*,

shaft L, and lever M, all substantially as and for the purposes herein set forth.

4. In combination with the main frame A, and carriage B, the adjustable guide-bar *g*, and set-screws *ff*, substantially as and for the purposes herein set forth.

5. The combination of the posts *t t'*, slide *v*, angular lever H, lug *s*, and swinging bearing-bar *d*, all substantially as and for the purposes herein set forth.

In testimony that we claim the foregoing we have hereunto set our hands and seals this 18th day of August, 1871.

DELOY F. SUTTON. [L. S.]
BERNARD MEILINK. [L. S.]

Witnesses:

CHAS. PRATT,
CHAS. C. STARR.

(173)