



- (51) **International Patent Classification:**
H03K 3/288 (2006.01) H03K 3/356 (2006.01)
- (21) **International Application Number:**
PCT/US2016/035525
- (22) **International Filing Date:**
2 June 2016 (02.06.2016)
- (25) **Filing Language:** English
- (26) **Publication Language:** English
- (30) **Priority Data:**
14/748,840 24 June 2015 (24.06.2015) US
- (63) **Related by continuation (CON) or continuation-in-part (CIP) to earlier application:**
US 14/748,840 (CON)
Filed on 24 June 2015 (24.06.2015)
- (71) **Applicant:** INTEL CORPORATION [US/US]; 2200 Mission College Boulevard, Santa Clara, California 95054 (US).
- (72) **Inventor:** AW, Chee Hong; 25, Jalan Kangar 87, Kaw 19, Off Jalan Kapar, 41400 Klang / 10 (MY).
- (74) **Agents:** PERDOK, Monique M. et al.; Schwegman Lundberg & Woessner, P.A., c/o CPA Global, 900 Second Av-

enue South, Suite 600, Minneapolis, Minnesota 55402 (US).

- (81) **Designated States** (unless otherwise indicated, for every kind of national protection available): AE, AG, AL, AM, AO, AT, AU, AZ, BA, BB, BG, BH, BN, BR, BW, BY, BZ, CA, CH, CL, CN, CO, CR, CU, CZ, DE, DK, DM, DO, DZ, EC, EE, EG, ES, FI, GB, GD, GE, GH, GM, GT, HN, HR, HU, ID, IL, IN, IR, IS, JP, KE, KG, KN, KP, KR, KZ, LA, LC, LK, LR, LS, LU, LY, MA, MD, ME, MG, MK, MN, MW, MX, MY, MZ, NA, NG, NI, NO, NZ, OM, PA, PE, PG, PH, PL, PT, QA, RO, RS, RU, RW, SA, SC, SD, SE, SG, SK, SL, SM, ST, SV, SY, TH, TJ, TM, TN, TR, TT, TZ, UA, UG, US, UZ, VC, VN, ZA, ZM, ZW.
- (84) **Designated States** (unless otherwise indicated, for every kind of regional protection available): ARIPO (BW, GH, GM, KE, LR, LS, MW, MZ, NA, RW, SD, SL, ST, SZ, TZ, UG, ZM, ZW), Eurasian (AM, AZ, BY, KG, KZ, RU, TJ, TM), European (AL, AT, BE, BG, CH, CY, CZ, DE, DK, EE, ES, FI, FR, GB, GR, HR, HU, IE, IS, IT, LT, LU, LV, MC, MK, MT, NL, NO, PL, PT, RO, RS, SE, SI, SK, SM, TR), OAPI (BF, BJ, CF, CG, CI, CM, GA, GN, GQ, GW, KM, ML, MR, NE, SN, TD, TG).

Published:

— with international search report (Art. 21(3))

(54) **Title:** LATCHED COMPARATOR CIRCUIT

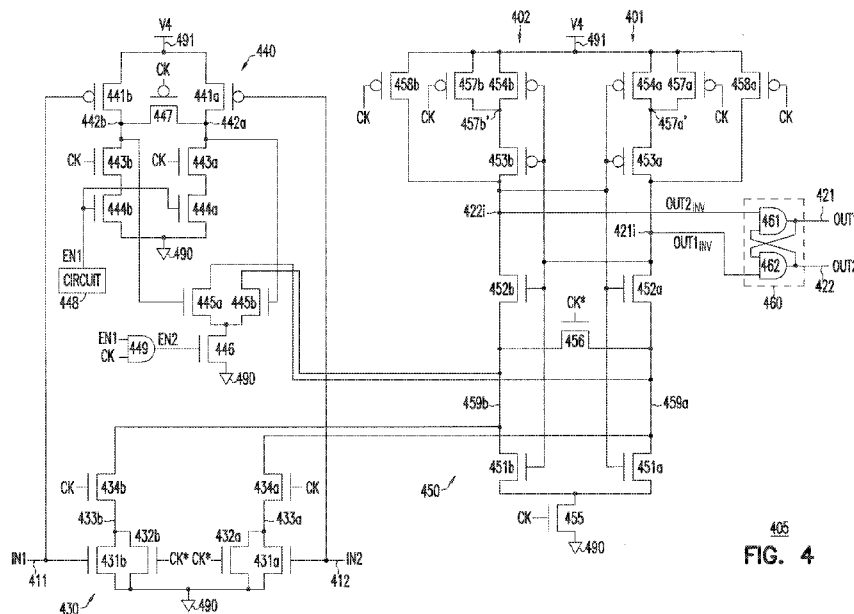
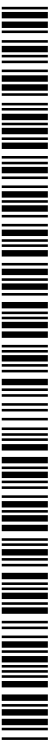

FIG. 4

(57) **Abstract:** Some embodiments include apparatuses having input nodes to receive input signals, output nodes to provide output signals, a first stage including a first pair of input transistors, the first pair of transistors including gates coupled to the input nodes, a second stage including a second pair of input transistors, the second pair of transistors including gates coupled to the input nodes, and a third stage including inverters coupled to the output nodes. The inverters are coupled to the first and second stages at the same nodes to switch the output signals between different voltages based on the input signals.



LATCHED COMPARATOR CIRCUIT

Claim of Priority

5 [0001] This international application claims the benefit of priority to US patent application serial number 14/748,840 filed June 24, 2015, the entire contents of which are hereby incorporated by reference herein in its entirety.

Technical Field

10 [0002] Embodiments described herein pertain to circuits. Some embodiments relate to comparators.

Background

[0003] Comparator circuits are included in many electronic devices and
15 systems, such as cellular phones, computers, televisions, and other electronic items. Comparator circuits can be used to compare input signals and generate output signals based on the input signals. Different devices and systems may use different comparator circuits having different operating specifications. Examples of such operating specifications are voltage ranges for input signals,
20 operating speed, value for supply voltage, power consumption, and comparator size. Designing comparator circuits having operating specifications suitable for some devices and systems may pose a challenge.

Brief Description of the Drawings

25 [0004] FIG. 1 shows an apparatus including devices having comparators and a connection between the devices, according to some embodiments described herein.

[0005] FIG. 2 shows an apparatus that can be a variation of the apparatus of FIG. 1, according to some embodiments described herein.

30 [0006] FIG. 3A is an example timing diagram for some of the signals for the apparatus of FIG. 1, according to some embodiments described herein.

[0007] FIG. 3B is an example timing diagram for some of the signals for the apparatus of FIG. 2, according to some embodiments described herein.

[0008] FIG. 4 shows a schematic diagram of an apparatus in the form of a comparator, according to some embodiments described herein.

5 [0009] FIG. 5 is an example timing diagram for some of the signals for the comparator of FIG. 4 operating with a relatively low input common-mode voltage, according to some embodiments described herein.

[0010] FIG. 6 is an example timing diagram for some of the signals for the comparator of FIG. 4 operating with a relatively high input common-mode
10 voltage, according to some embodiments described herein.

[0011] FIG. 7 shows a schematic diagram of an example relationship between clock and output signals of the comparator of FIG. 4, according to some embodiments described herein.

[0012] FIG. 8 shows a schematic diagram of an apparatus in the form of another comparator, which can be a variation of the comparator of FIG. 4,
15 according to some embodiments described herein.

[0013] FIG. 9 shows a schematic diagram of an apparatus in the form of a memory device, according to some embodiments described herein

[0014] FIG. 10 shows an apparatus in the form of a system (e.g., an
20 electronic system), according to some embodiments described herein.

Detailed Description

[0015] FIG. 1 shows an apparatus 100 including devices 101 and 102, and a connection 103 between devices 101 and 102, according to some
25 embodiments described herein. Apparatus 100 can include or be included in an electronic device or system, such as a computer (e.g., server, desktop, laptop, or notebook), a tablet, a cellular phone, or other electronic devices or systems.

[0016] Devices 101 and 102 can include integrated circuit (IC) chips 104 and 107, respectively. Each of IC chips 104 and 107 can include a
30 semiconductor die (e.g., silicon die). IC chips 104 and 107 may be included in IC packages 108 and 109, respectively. Devices 101 and 102 can include a combination of processors (e.g., general-purpose processors, application specific

integrated circuit (ASICs)), input/output (I/O) controllers, graphics controllers, memory devices, or other electronic devices.

[0017] Connection 103 can include conductive paths (e.g., links) 103₀, 103₁, 103₂, and 103₃ to conduct signals. Each of conductive paths 103₀ through 103₃ can include conductive traces (e.g., wirelines such as metal-based traces) on a circuit board (e.g., printed circuit board) where devices 101 and 102 are located. Conductive paths 103₀ through 103₃ can include a bus or can be part of a bus of a circuit board. Devices 101 and 102 can communicate with each other by providing signals on conductive paths 103₀ through 103₃. FIG. 1 shows connection 103 having four conductive paths 103₀ through 103₃ as an example. The number of conductive paths may vary.

[0018] Devices 101 and 102 can include a transmitter 110 and a receiver 120, respectively. Transmitter 110 may transmit signals IN₁₀, IN₁₁, IN₁₂, and IN₁₃ to receiver 120 on conductive paths 103₀, 103₁, 103₂, and 103₃, respectively.

[0019] Each of signals IN₁₀, IN₁₁, IN₁₂, and IN₁₃ can have values (e.g., voltage values) that represent the values of information (e.g., data) sent from transmitter 110 to receiver 120. Each of signals IN₁₀, IN₁₁, IN₁₂, and IN₁₃ can be a single-ended signal.

[0020] Device 102 can include nodes (e.g., input nodes) 111₀, 111₁, 111₂, and 111₃. Each of nodes 111₀, 111₁, 111₂, and 111₃ can include a conductive contact (e.g., solder ball, solder bump, pin, pad, or other types of conductive contacts) located on (e.g., formed on or formed in) IC chip 104 or located on (e.g., formed on or formed in) IC package 108 of device 102. As shown in FIG. 1, nodes 111₀, 111₁, 111₂, and 111₃ can be coupled to conductive paths 103₀, 103₁, 103₂, and 103₃, respectively, to receive corresponding signals (e.g., input signals) IN₁₀, IN₁₁, IN₁₂, and IN₁₃.

[0021] Device 102 can also include nodes (e.g., input nodes) 112₀, 112₁, 112₂, and 112₃, which can be internal nodes of device 102. Nodes 112₀, 112₁, 112₂, and 112₃ may not be arranged to receive signals from connection 103. Nodes 112₀, 112₁, 112₂, and 112₃ may be arranged to receive signals (e.g., input signals) IN₂₀, IN₂₁, IN₂₂, and IN₂₃, which may be generated by device 102. Signals IN₂₀, IN₂₁, IN₂₂, and IN₂₃ can have the same value. For example,

device 102 may generate a reference signal (e.g., a constant reference voltage signal V_{REF} , not shown in FIG. 1). Signals IN_{20} , IN_{21} , IN_{22} , and IN_{23} can have the same value provided by the reference signal (e.g., signal V_{REF}).

[0022] Receiver 120 of device 102 can include comparators 105₀, 105₁, 5 105₂, and 105₃. Each of the comparators described with reference to FIG. 1 through FIG. 10 can include a latched comparator (e.g., a comparator that is clocked by at least one clock signal during its operation). Thus, in FIG. 1, each of comparators 105₀, 105₁, 105₂, and 105₃ can include a latched comparator (e.g., a strong-arm type latch), such that each of comparators 105₀, 105₁, 105₂, 10 105₃ can be clocked by at least one clock signal during the operation of each comparator. Receiver 120 can operate a relatively high frequency (e.g., operate using a clock signal having a frequency in the gigahertz range). Comparators 105₀, 105₁, 105₂, and 105₃ can receive signals IN_{10} , IN_{11} , IN_{12} , IN_{13} , IN_{20} , IN_{21} , IN_{22} , and IN_{23} and generate signals (output signals) OUT_{10} , OUT_{11} , 15 OUT_{12} , OUT_{13} , OUT_{20} , OUT_{21} , OUT_{22} , and OUT_{23} , which can be provided to a functional unit (e.g., logic unit) 121 of device 102 for further processing.

[0023] Each particular comparator among comparators (e.g., latched comparators) 105₀, 105₁, 105₂, and 105₃ of receiver 120 can generate output signals having values based on the values of input signals received by that 20 particular comparator. For example, comparator 105₀ can generate signals OUT_{10} and OUT_{20} having values based on the values of signals IN_{10} and IN_{20} . Comparator 105₁ can generate signals OUT_{11} and OUT_{21} having values based on the values of signals IN_{11} and IN_{21} . Comparator 105₂ can generate signals OUT_{12} and OUT_{22} having values based on the values of signals IN_{12} and IN_{22} . 25 Comparator 105₃ can generate signals OUT_{13} and OUT_{23} having values based on the values of signals IN_{13} and IN_{23} . FIG. 1 shows receiver 120 having four comparators 105₀, 105₁, 105₂, and 105₃ as an example. The number of comparators in receiver 120 may vary.

[0024] FIG. 2 shows an apparatus 200 that can be a variation of 30 apparatus 100 of FIG. 1, according to some embodiments described herein. Apparatus 200 can include elements similar to, or identical to, apparatus 100. For simplicity, similar or identical elements in apparatuses 100 and 200 are given the same designation labels.

[0025] In apparatus 200, signals IN2₀, IN2₁, IN2₂, and IN2₃ may be generated by transmitter 110 of device 101 (instead of by device 102 as in the example of FIG. 1). In FIG. 2, connection 103 can include additional conductive paths 203₀, 203₁, 203₂, and 203₃ to transmit signals IN2₀, IN2₁, IN2₂, and IN2₃, respectively, from transmitter 110 to receiver 120. Device 102 of apparatus 200 can include nodes (e.g., input nodes) 212₀, 212₁, 212₂, and 212₃ coupled to conductive paths 103₀, 103₁, 103₂, and 103₃, respectively, to receive corresponding signals IN2₀, IN2₁, IN2₂, and IN2₃. Each of nodes 212₀, 212₁, 212₂, and 212₃ can include a conductive contact (e.g., solder ball, solder bump, pin, pad, or other types of conductive contacts) located on (e.g., formed on or formed in) IC chip 104 or located on (e.g., formed on or formed in) IC package 108 of device 102.

[0026] In apparatus 200, signals IN1₀, IN1₁, IN1₂, IN1₃, IN2₀, IN2₁, IN2₂, and IN2₃ can be different signals. For example, each of signal pairs IN1₀ and IN2₀, IN1₁ and IN2₁, IN1₂ and IN2₂, and IN1₃ and IN2₃ can be a different pair.

[0027] FIG. 3A is an example timing diagram for some of the signals for apparatus 100 of FIG. 1, according to some embodiments described herein. In FIG. 3A, signal IN1 can represent one of signals IN1₀, IN1₁, IN1₂, and IN1₃ of FIG. 1. Signal IN2 can present one of signals IN2₀, IN2₁, IN2₂, and IN2₃ of FIG. 1. As mentioned above with reference to the description of FIG. 1, signals IN2₀, IN2₁, IN2₂, and IN2₃ can have the same value provided by a reference signal (e.g., signal V_{REF}). Thus, in FIG. 3A, signal IN2 can be provided by a reference signal (e.g., signal V_{REF}) that can be used for comparison with signal IN1. As shown in FIG. 3A, signal IN1 can change (e.g., swing) between voltages V1 and V3. Signal IN2 can remain at voltage V2. Voltages V1 and V3 can have values based on the values (e.g., binary 0 and binary 1) of information transmitted from transmitter 110 to receiver 120.

[0028] The difference in values between voltages V2 and V1 (e.g., delta 1) and the difference in values between voltages V3 and V2 (e.g., delta 2) can be the same or can be different. As an example, delta 1 or delta 2 can be approximately 50mV (millivolt) and voltage V4 can be approximately 0.89V. Other values of voltage V4 delta 1 and delta 2 may be used.

[0029] As shown in FIG. 3A, each of voltages V1, V2, and V3 can be greater than voltage V0 and less than voltage V4. Voltages V0 and V4 can include supply voltages (e.g., rail supply voltages) of comparators 105₀, 105₁, 105₂, and 105₃ (FIG. 1 and FIG. 2). For example, voltages V0 and V4 can include supply voltages V_{ss} and V_{cc}. The value of voltage V0 can include ground potential (e.g., zero volts).

[0030] In FIG. 3A, signal (e.g., output signal) OUT1 can represent one of signals OUT1₀, OUT1₁, OUT1₂, and OUT1₃ of FIG. 1. Signal OUT2 (e.g., output signal) in FIG. 3A can present one of signals OUT2₀, OUT2₁, OUT2₂, and OUT2₃ of FIG. 1. The values of signals (e.g., output signals) OUT1 and OUT2 can be based on the values of signals (e.g., input signals) IN1 and IN2. For example, as shown in FIG. 3A, signal OUT1 can have a value at voltage V0 (e.g., ground) when the value (e.g., value of voltage V3) signal IN1 is greater than the value (e.g., value of voltage V2) of signal IN2. Signal OUT1 can have a value at approximately the value of voltage V4 when the value (e.g., value of voltage V1) signal IN1 is less than the value (e.g., value of voltage V2) of signal IN2. Thus, signal OUT1 can change (e.g., swing) between voltages V0 and V4 when signal IN1 changes between voltages V1 and V3. Signal OUT2 can have values (e.g., voltages) opposite from the values of signal OUT1, as shown in FIG. 3A.

[0031] FIG. 3B is an example timing diagram for some of the signals for apparatus 200 of FIG. 2, according to some embodiments described herein. Signal IN1 can represent one of signals IN1₀, IN1₁, IN1₂, and IN1₃ of FIG. 2. Signal IN2 can present one of signals IN2₀, IN2₁, IN2₂, and IN2₃ of FIG. 2. Signals IN1 and IN2 in FIG. 3B can be different signals (e.g., a differential pair). For example, as shown in FIG. 3B, signal IN1 can change (e.g., swing) between voltages V1 and V3. Signal IN2 can also change (e.g., swing) between voltages V1 and V3 but in an opposite direction from that of signal IN1.

[0032] In FIG. 3B, signal (e.g., output signal) OUT1 can represent one of signals OUT1₀, OUT1₁, OUT1₂, and OUT1₃ of FIG. 2. Signal OUT2 (e.g., output signal) in FIG. 3B can present one of signals OUT2₀, OUT2₁, OUT2₂, and OUT2₃ of FIG. 2. The values of signals (e.g., output signals) OUT1 and OUT2 can be based on the values of signals (e.g., input signals) IN1 and IN2.

For example, as shown in FIG. 3B, signal OUT1 can have a value at voltage V0 (e.g., ground) when the value (e.g., value of voltage V3) signal IN1 is greater than the value (e.g., value of voltage V1) of signal IN2. Signal OUT1 can have a value at approximately the value of voltage V4 when the value (e.g., value of
5 voltage V1) signal IN1 is less than the value (e.g., value of voltage V3) of signal IN2. Signal OUT2 can have values (e.g., voltages) opposite from the values of signal OUT1, as shown in FIG. 3B.

[0033] Each of comparators 105₀, 105₁, 105₂, and 105₃ described above with reference to FIG. 1, FIG. 2, FIG. 3A, and FIG. 3B can include a comparator
10 described below with reference to FIG. 4 through FIG. 10.

[0034] FIG. 4 shows a schematic diagram of an apparatus in the form of a comparator 405, according to some embodiments described herein.

Comparator 405 can operate as a latched comparator (e.g., a strong-arm type latch), such that it can be clocked by clock signals CK and CK*. Signals CK and CK* can be complementary signals (e.g., complementary clock signals).
15 Comparator 405 can be used as a latched comparator for each of comparators 105₀, 105₁, 105₂, and 105₃ of FIG. 1 and FIG. 2. Comparator 405 can be included in a high-speed receiver, high-speed data link circuitry, on-package interconnect (OPI) circuitry, and other communication devices or systems. The
20 high-speed operation described herein can include circuitry (e.g., comparator 405 of FIG. 4 and receiver 120 of FIG. 1) that operates with clock signals in the gigahertz range. Thus, comparator 405 can be a latched comparator, which is clocked by clock signals (e.g., CK and CK*) having a clock frequency in the gigahertz range.

[0035] As shown in FIG. 4, comparator 405 can include nodes 411 and 412 to receive signals IN1 and IN2, respectively, and nodes 421 and 422 to provide signals OUT1 and OUT2, respectively. Nodes 411 and 412 and signals IN1 and IN2 can be referred to as comparator input nodes and comparator input signals, respectively. Nodes 421 and 422 and signals OUT1 and OUT2 can be
30 referred to as comparator output nodes and comparator output signals, respectively.

[0036] Comparator 405 can be included in receiver 120 of FIG. 1, such that node 411 can be coupled to (or can be part of) one of nodes 111₀, 111₁,

111₂, and 111₃, and such that node 412 can be coupled to (or can be part of) one of nodes 112₀, 112₁, 112₂, and 112₃.

[0037] Comparator 405 can also be included in receiver 120 of FIG. 2, such that node 411 can be coupled to (or can be part of) one of nodes 111₀, 111₁, 111₂, and 111₃, and such that node 412 can be coupled to (or can be part of) one of nodes 212₀, 212₁, 212₂, and 212₃.

[0038] Thus, signal IN1 in FIG. 4 can be one of signals IN1₀, IN1₁, IN1₂, and IN1₃ of FIG. 1 or FIG. 2. Signal IN2 in FIG. 4 can be one of signals IN2₀, IN2₁, IN2₂, and IN2₃ of FIG. 1 or FIG. 2.

10 [0039] As shown in FIG. 4, comparator 405 can include nodes (e.g., supply nodes) 490 and 491 to receive voltages V0 and V4, respectively. Voltages V0 and V4 can include supply voltages (e.g., V_{ss} and V_{cc}, respectively) of comparator 405.

[0040] Comparator 405 can use clock signals CK and CK* to control (e.g., turn on or turn off) some of the transistors (described below) in comparator 405. Signals CK and CK* can be generated by a device (e.g., device 102 of FIG. 1) that includes comparator 405.

[0041] Comparator 405 can include stages (e.g., circuits) 430, 440, and 450, each of which can include transistors arranged (e.g., coupled among each other) in an arrangement shown in FIG. 4. Stage 430 (e.g., input stage) can operate to receive signals IN1 and IN2. Stage 440 (e.g., input assist stage) can operate to assist stage 430 in some situations (e.g., when input common-mode voltage is relatively low) to allow comparator 405 to operate at a relatively wide input common-mode range (e.g., wide input swing). For example, stage 440 can be configured to assist stage 430 to sample signals IN1 and IN2 when a value of at least one of signals IN1 and IN2 is less than one-half of a value of an operating voltage (e.g., voltage V4) of stage 450 (e.g., the operating voltage of comparator 405). Stage 450 (e.g., output stage) can operate to generate signals OUT1 and OUT2 based on signals IN1 and IN2 received at stages 430 and 440. Signals OUT1 and OUT2 can have a signal swing between ground (e.g., V0) and supply voltage (e.g., V4) of comparator 405. Each of signals OUT1 and OUT2 may be used to represent the values (e.g., binary 0 and binary 1) of information (e.g., a bit of information).

[0042] As shown in FIG. 4, stage 430 can include transistors (e.g., input transistors or input transistor pair) 431a and 431b having gates to receive (e.g., sample) signals IN2 and IN1, respectively. Transistors 431a and 431b can include a transistor type (e.g., N-type transistor) to allow them to properly receive (e.g., sample) input signals having a relatively high input common-mode voltage (e.g., a common-mode voltage closer to the supply voltage of comparator 405). Examples of n-type transistors include n-channel transistors (n-channel metal oxide semiconductor (NMOS) transistors).

[0043] Stage 440 can include transistors (e.g., input transistors or input transistor pair) 441a and 441b having gates to receive (e.g., sample) the same input signals (e.g., signals IN2 and IN1) received by transistors 431a and 431b of stage 430. However, transistors 441a and 441b of stage 440 can have a transistor type (e.g., p-type) that is different from the transistor type (e.g., n-type) of transistors 431a and 431b of stage 430. Examples of p-type transistors include p-channel transistors (p-channel metal oxide semiconductor (PMOS) transistors). Having a different transistor type from transistors 431a and 431b allows transistors 441a and 441b of stage 440 to assist (e.g., complement) transistors 431a and 431b of stage 430 when the input signals have a relatively low input common-mode voltage (e.g., a common-mode voltage closer to ground). Since stage 440 can assist stage 430 to allow comparator 405 to operate at a wider input common-mode range, stage 440 may operate as a wide-swing enabler in comparator 405.

[0044] Thus, as described above, comparator 405 includes different types (NMOS and PMOS) of input transistors to receive the same input signals (e.g., IN1 and IN2). This may allow comparator 405 to operate at a relatively higher speed and a relatively wider input common-mode range (a range between an input common-mode voltage closer to supply voltage of comparator 405 and an input common-mode voltage closer to ground) in comparison with some conventional comparators (e.g., strong-arm type latches).

[0045] Some particular conventional comparators may operate a relatively wider input common-mode range than other conventional comparators. However, in comparison with such particular conventional comparators, comparator 405 may have a smaller input circuit to receive input

signals and a smaller logic circuitry to support the input circuit, may consume less power (e.g., less current), may have a lower input capacitance, and may operate at a relatively low supply voltage (e.g., a voltage of less than 1V).

[0046] The combination of stages 430 and 440 in the same comparator
5 405 may also allow it to operate at similar speed (e.g., at mostly uniform speed) at different values of the input signals (e.g., IN1 and IN2) within the input common-mode range. This is another improvement of comparator 405 over some conventional comparators. For example, some conventional comparators (e.g., either N-type or P-type strong-arm latches) may operate at a lower speed
10 when the input common-mode voltage is approximately one-half of the supply voltage (e.g., near middle of the input common-mode range). The lower speed may be caused by the input transistor pair (e.g., either NMOS or PMOS transistor pair) of the conventional comparators not being fully turned on when input common-mode voltage is approximately one-half of the supply voltage. In
15 comparator 405, since it has a combination of both types (e.g., NMOS and PMOS) of input transistors to receive the same input signals (e.g., IN1 and IN2), the lower speed limitation may be avoided.

[0047] Stages 430 and 440 can also include additional transistors that can be arranged as shown in FIG. 4 and can be controlled by corresponding signals
20 (e.g., CK, CK*, EN1, and EN2) at their gates. For example, stage 430 can include transistors (e.g., NMOS transistors) 432a and 432b controlled by signal CK*, and transistors (e.g., NMOS transistors) 434a, and 434b controlled by signal CK. Stage 440 can include transistors (e.g., NMOS transistors) 443a and 443b controlled by signal CK, transistors (e.g., NMOS transistors) 444a and
25 444b controlled by signal EN1, transistors (e.g., NMOS transistors) 445a and 445b controlled by the signals at nodes 442b and 442a, respectively, a transistor 446 (e.g., NMOS transistors) controlled by signal EN2, and a transistor (e.g., PMOS transistor) 447 controlled by signal CK. Transistors 443a, 443b, 444a, and 44b may be sized smaller than other transistors of comparator 405 to reduce
30 power consumption

[0048] Stage 440 can be arranged to receive a signal EN1 (e.g., stage enable signal) from a circuit (e.g., enable/disable circuit) 448. Circuit 448 can operate such that it can provide signal EN1 with a value (e.g., high) to active

(e.g., enable) stage 440 in some situations and another value (e.g., low) to deactivate (e.g., disable) stage 440 some other situations. For example, in a situation where signals IN1 and IN2 are known to operate with both low and high common-mode voltages, circuit 448 may be arranged to provide signal EN1 with a value to activate stage 440 in order to allow comparator 405 to accurately sample signals IN1 and IN2. In another example, in a situation where signals IN1 and IN2 are known to operate with a high input common-mode voltage, circuit 448 may be arranged to provide signal EN1 with another value to deactivate stage 440 while stages 430 and 450 remain activated (e.g., remain operational). Deactivating stage 440 in some situations may save power in comparator 405.

[0049] Stage 440 can also be arranged to receive a signal EN2 (e.g., stage enable signal) from a circuit 449, which can include a logic gate (e.g., AND gate). Circuit 449 can operate such that when stage 440 is activated (e.g., by signal EN1), circuit 449 can provide signal EN2 with a value (e.g., high or low) to turn on or turn off transistor 446 based on the combination of signals EN1 and CK.

[0050] Stage 450 can include transistors 451a, 452a, 453a, and 454a coupled between nodes 490 and 491 (e.g., coupled in a stack arrangement) and can be part of an inverter 401. Stage 450 can also include transistors 451b, 452b, 453b, and 454b coupled between nodes 490 and 491 (e.g., coupled in a stack arrangement) and can be part of an inverter 402.

[0051] Inverters 401 and 402 can be arranged in a back-to-back crossed coupled configuration, such that the input of inverter 401 and the output of inverter 402 is coupled to each other at node (e.g., inverter output node) 422i, and the input of inverter 402 and the output of inverter 401 is coupled to each other at node 421i (e.g., inverter output node).

[0052] Stage 450 can include a node 459a between transistors 451a and 452a and a node 459b between transistors 451b and 452b. Nodes 459a and 459b can create tapping points in inverters 401 and 402 of stage 450 for connection to stages 430 and 440. For example, as shown in FIG. 4, transistor 431a of stage 430 can be coupled between node 459a and node 490, and transistor 431b of

stage 430 can be coupled between node 459b and node 490. Transistors 445a and 454b of stage 440 can be coupled to nodes 459a and 459b, respectively.

[0053] In comparison with some conventional comparators (e.g., strong-arm type latches having inverters and input pairs connected in a cascade

5 manner), the arrangement between inverters 401 and 402 and transistors 431a and 431b (e.g., a folded arrangement as shown in FIG. 4) may allow comparator 405 to have a better headroom and to operate at a higher speed (e.g., a higher clock frequency). It may also allow comparator 405 to operate at a relatively low supply voltage (e.g., a supply voltage of less than 1V).

10 [0054] Stage 450 can also include additional transistors that can be arranged as shown in FIG. 4 and can be controlled by corresponding signals (e.g., CK and CK*) at their gates. For example, stage 450 can include transistors (e.g., NMOS transistors) 455 and 456 controlled by signals CK and CK*, respectively, and transistors (e.g., PMOS transistors) 457a, 457b, 458a, and 458b
15 controlled by signals CK. In an alternative arrangement, transistor 457a can be eliminated. Transistors 453a and 454a can be replaced by a single transistor between nodes 421i and 491. The single transistor can have a size that matches a combined size of transistors 451a and 452a. In the alternative arrangement, transistor 457b can also be eliminated. Transistors 453b and 454b can be
20 replaced by a single transistor (between nodes 422i and 491), which can have a size that matches a combined size of transistors 451b and 452b.

[0055] Stage 450 can include a circuit 460 (e.g., a reset-set (RS) type latch) to provide signals OUT1 and OUT2 based on signals OUT1_{INV} and OUT2_{INV} (e.g., inverter output signals). Circuit 460 can include logic gates (e.g.,
25 logic NAND gates) 461 and 462 arranged (e.g., coupled among each other) in an arrangement shown in FIG. 4.

[0056] In operation, comparator 405 may include a reset (precharge) phase, a sampling phase, a regeneration phase, and a decision phase.

[0057] In the reset phase, transistors 443a and 443b of stage 430 can be
30 turned off. Transistors 432a and 432b of stage 430 can be turned on to equalize the voltages of nodes 433a and 433b (e.g., to cause nodes 433a and 433b to have the same voltage, such as voltage V₀). This allows comparator 405 to accurately sample (e.g., accurately receive) signals IN1 and IN2 during the sampling phase

(performed after the reset phase). Transistor 447 of stage 440 can be turned on to equalize the voltages of nodes 442a and 442b.

[0058] Transistor 455 of stage 450 can be turned off. Transistors 457a, 457b, 458a, and 458b can be turned on to charge nodes 421i, 422i, 457a', and 457b' to voltage V4 (e.g., supply voltage V_{cc} of comparator 405). Transistor 5 456 can be turned on to equalize the voltages of nodes 459a and 459b. Thus, in the reset phase, both sides (e.g., nodes 421i and 422i) of inverters 401 and 402 can have the same voltage (e.g., voltage V4), thereby creating an equilibrium state that is unstable and high gain for the circuit of comparator 405.

10 [0059] In the sampling phase, transistors 432a and 432b of stage 430 can be turned off. One side of each of stages 430 and 440 can receive signal IN2 at node 412, which is coupled to the gate of transistor 431a of stage 430 and the gate of transistor 441a of stage 440. The other side of each of stages 430 and 440 can receive signal IN1 at node 411, which is coupled to the gate of transistor 15 431a of stage 430 and the gate of transistor 441a of stage 440.

[0060] Transistors 434a and 434b of stage 430 can be turned on to couple transistors 431a and 431b of stage 430 to nodes 459a and 459b, respectively. Transistors 445a and 445b stage 440 can be turned on to couple transistors 441b and 441a of stage 440 to nodes 459a and 459b, respectively.

20 [0061] As described above, transistors 431a and 431b of stage 430 can include NMOS transistors and transistors 441a and 441b of stage 440 can include PMOS transistors. Transistors 441a and 441b can have a smaller size than transistors 431a and 432b. NMOS transistors may normally be faster (e.g., switch faster) than PMOS transistors. Thus, the operation in the sampling phase 25 of comparator 405 may mainly be achieved by (e.g., dominated by) transistors 431a and 431b of stage 430, especially when input common-mode voltage in the sampling phase is relatively high.

[0062] In the sampling phase, when the value (e.g., voltage value) of signal IN1 is greater than the value (e.g., voltage value) of signal IN2, node 459b 30 may have a lower voltage than node 459a. Due to a lower voltage at 459b, transistor 452b (for which its gate is still at voltage V4 (e.g., precharged at voltage V4 from the reset phase)) may see higher voltage V_{DS} (drain-to-source voltage) than transistor 452a. Thus current I_{DS} (drain-to-source current) of

transistor 452b may be greater than current I_{DS} across transistor 452a. Therefore, transistor 452b may sink more current from node 422i. This may create a disturbance to the unstable equilibrium state of comparator 405. Due to the push-pull effect in the regeneration phase (described below), the voltages at nodes 421i and 422i may continue to be pulled in opposite directions. For example, the voltage of node 422i may be pulled (e.g., pulled down) until it reaches the value of voltage V_0 (e.g., ground) of node 490. The voltage at node 421i may be pulled (e.g., pulled up) until it reaches the value of the voltage (e.g., $V_4 = V_{CC}$) at node 491.

10 **[0063]** As mentioned above, transistors 431a and 431b of stage 430 can include NMOS transistors. Thus, if input common-mode voltage in the sampling phase is relatively low, transistors 431a and 431b of stage 430 may not be in full function (e.g., may not fully turned on) because NMOS transistors may normally operate at gate-to-source voltage (V_{GS}) being greater than the transistor threshold voltage (V_t) in order to be in full function (e.g., fully turned on). In this situation, transistors 441a and 441b (which can include PMOS transistors) of stage 440 may operate to assist the sampling operation. For example, when the value (e.g., voltage value) of signal IN1 is greater than the value (e.g., voltage value) of signal IN2, node 442a may have higher voltage than node 442b because transistor 441a may have a larger V_{GS} than transistor 441b and a lower R_{ON} (transistor on-resistance) than transistor 441b. A higher voltage at node 442b may cause transistor 445b to have a larger V_{GS} than transistor 445a and may cause transistor 445b to sink more current from node 459b. Due to a lower voltage at 459b, transistor 452b (for which its gate is still at voltage V_4 (e.g., precharged at voltage V_4 from the reset phase)) may see higher voltage V_{DS} . Thus, current I_{DS} of transistor 452b may be greater than current I_{DS} across transistor 452a. This situation is similar to the situation when input common-mode voltage is not low and the trigger is done by transistors 431a and 431b. For example, voltage levels at nodes 421i and 422i may be pulled to opposite directions until they reach the value of the voltages V_0 and V_4 .

25 **[0064]** Thus, in the operations described above, stage 440 (e.g., based at least on the operation of transistors 441a and 441b) may operate to assist (e.g.,

complement) stage 430 (e.g., assist at least the function of transistors 431a and 431b) when input common-mode voltage is relatively low.

[0065] In the regeneration phase and decision phase, after receiving initial trigger from transistors 431a and 431b, the voltages at nodes 421i and 422i of inverters 401 and 402 may continue to be pulled until they reach voltages V0 and V4, respectively.

[0066] FIG. 5 is an example timing diagram for some of the signals for comparator 405 of FIG. 4 operating with a relatively low input common-mode voltage, according to some embodiments described herein. In the example of FIG. 4, the low input common-mode voltage comparator 405 may operate at a temperature of -40°C, voltage V4 of approximately 0.89V, and signal CK and CK* having a frequency 4GHz (gigahertz). As described above, transistors 441a and 441b of stage 440 can include PMOS transistors. This allows comparator 405 (e.g., based at least on the operation of transistors 441a and 441b) to correctly sample low input common-mode voltage provided by signals IN1 and IN2. Inverters 401 and 402 of stage 450 can also toggle signals (e.g., inverter output signals) OUT1_{INV} and OUT2_{INV} between V0 (e.g., V_{CC}) and V4 (e.g., ground). This allows circuit 460 of stage 450 to properly switch each of signals (e.g., comparator output signals) OUT1 and OUT2 between voltages V0 and V4.

[0067] The timing diagram of FIG. 5 shows one of the improvements that comparator 405 may have over some conventional comparators. For example, at similar operating conditions (voltage, temperature, and clock frequency) described above in the example of FIG. 5 for comparator 405, inverters in some conventional comparators may be unable to toggle inverter output signals to ground. This may cause comparator output signals (which are based on the inverter output signals) of the conventional comparators to fail to switch or switch improperly. Thus, operational failure may occur in some conventional comparators. Comparator 405, however, may operate properly with a relatively low input common-mode voltage, as shown in the example of FIG. 5.

[0068] FIG. 6 is an example timing diagram for some of the signals for comparator 405 of FIG. 4 operating with a relatively high input common-mode voltage, according to some embodiments described herein. The operating

conditions for comparator 405 in the example timing diagrams of FIG. 5 and FIG. 6 can be the same (operating temperature of -40°C , voltage V_4 of approximately 0.89V , and signal CK and CK* having a frequency of 4GHz). As described above, transistors 431a and 431b of stage 430 can include NMOS
5 transistors. This allows comparator 405 (e.g., based at least on the operation of transistors 431a and 431b) to correctly sample high input common-mode voltage provided by signals IN1 and IN2. Inverters 401 and 402 of stage 450 can also toggle signals OUT1_{INV} and OUT2_{INV} between V_0 (e.g., V_{cc}) and V_4 (e.g., ground). This allows circuit 460 of stage 450 to properly switch each of signals
10 OUT1 and OUT2 between voltages V_0 and V_4 .

[0069] Thus, as shown in the example timing diagram of FIG. 6, comparator 405 may operate properly when the input common-mode voltage is relatively low or relatively high. This allows comparator 405 to operate at a wider input common-mode range in comparison with some conventional
15 comparators.

[0070] FIG. 7 shows a schematic diagram of an example relationship between clock and output signals of comparator 405 of FIG. 4, according to some embodiments described herein. The values of voltages (in mV) and time (in nanosecond (ns)) shown in FIG. 7 are example values. Other values may be
20 used. In FIG. 7, a time interval 701 represents a time delay (e.g., clock to output delay) between signals CK and OUT1_{INV} . The frequency of signal CK in FIG. 7 is approximately 4GHz . Time interval 701 has a value of approximately 19.71ps (picosecond). In comparison with some conventional comparators having a similar size and operating at a similar conditions (e.g., a supply voltage of $.89\text{V}$,
25 an operating temperature of -40°C , and a clock signal having a frequency of 4GHz), time interval 701 of comparator 405 may be less than (e.g., at least one-half less than) that of conventional comparators. Thus, comparator 405 may provide output information (e.g., signals OUT1 and OUT2) relatively faster than some conventional comparators.

[0071] FIG. 8 shows a schematic diagram of an apparatus in the form of a comparator 805, which can be a variation of comparator 405 of FIG. 4, according to some embodiments described herein. Comparator 805 can have the same type as comparator 405 (e.g., latched comparator) and can be clocked by
30

clock signals CK and CK* during its operation. As shown in FIG. 8, comparator 805 can include stages 430', 440', and 450' that can correspond to stages 430, 440, and 450, respectively, of comparator 405 of FIG. 4, and circuits 448', 449', and 460' that can correspond to circuits 448, 449, and 460 of comparator 405 of FIG. 4. However, as shown in FIG. 4 and FIG. 8, the transistor types in stages 430', 440', and 450' of comparator 805 in FIG. 8 can be different from the transistor types in corresponding stages 430, 440, and 450 of comparator 405 in FIG. 4.

[0072] For example, transistors 431a' and 431b' of stage 430' of comparator 805 can include a transistor type (e.g., PMOS) that is different from the transistor type (e.g., NMOS) of transistors 431a and 431b of stage 430 of comparator 405.

[0073] In another example, transistors 441a' and 441b' of stage 440' of comparator 805 can include a transistor type (e.g., PMOS) that is different from the transistor type (e.g., NMOS) of transistors 441a and 441b of stage 440 of comparator 405. In the arrangement of comparator 805, stage 440' can be configured to assist stage 430' to sample signals IN1 and IN2 when a value of at least one of signals IN1 and IN2 is greater than one-half of a value of an operating voltage (e.g., voltage V4) of stage 450' (e.g., the operating voltage of comparator 805).

[0074] Other transistors of comparator 805 can also have a different transistor type different from the transistor type corresponding transistors of comparator 405, as shown in FIG. 8. For simplicity, detailed description of differences between other corresponding transistors of comparators 405 and 805 in FIG. 8 is omitted from the description of FIG. 8.

[0075] Circuit 448' can operate such that signals EN1* for comparator 805 of can be a complement (e.g., inverted version) of signal EN1 for comparator 405 of FIG. 5. Circuit 449 in FIG. 8 can include a logic gate (e.g., OR gate) to provide signal EN2* with a value (e.g., high or low) to turn on or turn off transistor 446 based on the combination of signals EN1* and CK*.

[0076] FIG. 9 shows a schematic diagram of an apparatus in the form of a memory device 902, according to some embodiments described herein.

Memory device 902 can include memory cells 903 that can be arranged in rows

and columns a memory array 907. Memory device 902 can include a control unit 904 to control operations of memory device 902. Example of such operations may include a write operation to store (e.g., write) information in memory cells 903, a read operation to retrieve (e.g., read) information from memory cells 903, and an erase operation to clear (e.g., erase) information from some or all of memory cells 903.

[0077] Memory device 902 can include a sense circuit 905 having sense amplifiers 905₀, 905₁, 905₂, and 905₃. FIG. 9 shows sense circuit 905 having four sense amplifiers 905₀, 905₁, 905₂, and 905₃ as an example. The number of sense amplifiers in sense circuit 905 may vary. During a read operation of memory device 902, depending on which of memory cells 903 are selected to be accessed in order to retrieve information from the selected memory cells, sense circuit 905 can operate to selectively sense input signals at its inputs to provide corresponding output signals at its outputs. In FIG. 9, signals IN₁₀, IN₁₁, IN₁₂, IN₁₃, IN₂₀, IN₂₁, IN₂₂, and IN₂₃ can be input signals provided to inputs of sense circuits 905 during a read operation, and signals OUT₁₀, OUT₁₁, OUT₁₂, OUT₁₃, OUT₂₀, OUT₂₁, OUT₂₂, and OUT₂₃ can be output signals provided at outputs of sense circuit 905 during the read operation.

[0078] Memory device 902 can include an input/output (I/O) circuit 906 to generate information (e.g., output data) D₀ through D_N based on the output signals provided by sense circuit 905. Other devices (e.g., not shown, but can be a memory controller, a processor (e.g., CPU), or other devices) coupled to memory device 902 may receive output information D₀ through D_N from memory device 902 during a read operation for further processing.

[0079] In FIG. 9, each of signals IN₁₀, IN₁₁, IN₁₂, and IN₁₃ can be provided from a node on a data line (e.g., bit line) associated with a selected memory cell among memory cells 903. Each of signals IN₂₀, IN₂₁, IN₂₂, and IN₂₃ can be provided from a node on another data line (e.g., another bit line) associated with another memory cell (e.g., a non-selected memory cell, or alternatively a reference memory cell) among memory cells 903. Alternatively, each of signals IN₂₀, IN₂₁, IN₂₂, and IN₂₃ can be provided from a node that provides a signal (e.g., reference voltage signal V_{REF}) having a relatively

constant value (e.g., the value of voltage V2 associated with signal IN2 in FIG. 2).

[0080] As shown in FIG. 9, sense circuit 905 can include sense amplifiers (SAs) 905₀, 905₁, 905₂, and 905₃. Each of sense amplifiers 905₀, 905₁, 905₂, and 905₃ can include a latched comparator, such as comparator 405 of FIG. 4 or comparator 805 of FIG. 8. Thus, the operations of each of sense amplifiers 905₀, 905₁, 905₂, and 905₃ can be similar to, or identical to, the operations of comparator 405 of FIG. 4 or comparator 805 of FIG. 8 described above with reference to FIG. 4 through FIG. 8.

[0081] For example, during a read operation, signals IN1₀ and IN2₀ associated with a selected memory cell among memory cells 903 can be provided to sense amplifier 905₀. The value of at least one of signals IN1₀ and IN2₀ can be based on the value of information (e.g., a bit of information) stored in the selected memory cell. Sense amplifier 905₀ can operate in ways similar to comparator 405 to provide signals OUT1₀ and OUT2₀ having values (e.g., voltage V0 and V4) based on the values of signals IN1₀ and IN2₀.

[0082] Memory device 902 can include a volatile memory device (e.g., flash memory device), a non-volatile memory device (e.g., dynamic random access memory (DRAM) device), or combination of both. Memory device 902 can include other components, which are not shown in FIG. 9 to help focus on the embodiments described herein.

[0083] FIG. 10 shows an apparatus in the form of a system (e.g., an electronic system) 1000 according to some embodiments described herein. System 1000 can include or be included in electronic device or system, such as a computer (e.g., server, desktop, laptop, or notebook), a tablet, a cellular phone, or other electronic devices. As shown in FIG. 10, system 1000 can include a processor 1005, a memory device 1020, a memory controller 1030, a graphics controller 1040, an input and output (I/O) controller 1050, a display 1052, a keyboard 1054, a pointing device 1056, at least one antenna 1058, and a bus 1060.

[0084] In some arrangements, system 1000 does not have to include a display. Thus, display 1052 can be omitted from system 1000. In some

arrangements, system 1000 does not have to include any antenna. Thus, antenna 1058 can be omitted from system 1000.

[0085] Processor 1005 may include a general-purpose processor or an application specific integrated circuit (ASIC).

5 [0086] Memory device 1020 may include memory device 902 of FIG. 9. Memory device 1020 may include a dynamic random access memory (DRAM) device, a static random access memory (SRAM) device, a flash memory device, or a combination of these memory devices. FIG. 10 shows an example where memory device 1020 is a stand-alone memory device separated from processor
10 1005. In an alternative arrangement, memory device 1020 and processor 1005 can be located on the same die. In such an alternative arrangement, memory device 1020 is an embedded memory in processor 1005, such as embedded DRAM (eDRAM), embedded SRAM (eSRAM), embedded flash memory, or another type of embedded memory.

15 [0087] Display 1052 can include a liquid crystal display (LCD), a touchscreen (e.g., capacitive or resistive touchscreen), or another type of display. Pointing device 1056 can include a mouse, a stylus, or another type of pointing device.

[0088] I/O controller 1050 can include a communication module for
20 wired or wireless communication (e.g., communication through one or more antenna 1058). Such wireless communication may include communication in accordance with WiFi communication technique, Long Term Evolution Advanced (LTE-A) communication technique, or other communication techniques.

25 [0089] FIG. 10 shows the components of system 1000 arranged separately from each other as an example. For example, each of processor 1005, memory device 1020, memory controller 1030, graphics controller 1040, and I/O controller 1050 can be located on a separate die (e.g., semiconductor die or an IC chip). In some arrangements, two or more components (e.g., processor 1005,
30 memory device 1020, graphics controller 1040, and I/O controller 1050) of system 1000 can be located on the same IC chip.

[0090] Processor 1005, memory device 1020, memory controller 1030, graphics controller 1040, and I/O controller 1050 can include devices 101 and

102 of FIG. 1 or FIG. 2. For example, one of processor 1005, memory device 1020, memory controller 1030, graphics controller 1040, and I/O controller 1050 can include either device 102 of FIG. 1 or device 102 of FIG. 2. Thus, a particular component of system 1000 (e.g., one of processor 1005, memory
5 device 1020, memory controller 1030, graphics controller 1040, and I/O controller 1050) may include either a combination of nodes 111₀, 111₁, 111₂, and 111₃, 112₀, 112₁, 112₂, and 112₃ (FIG. 1) or a combination of nodes 111₀, 111₁, 111₂, and 111₃, 212₀, 212₁, 212₂, and 212₃ (FIG. 2).

[0091] As shown in FIG. 10, of processor 1005, memory device 1020,
10 memory controller 1030, graphics controller 1040, and I/O controller 1050 can include transceivers 1075a, 1075b, 1075c, 1075d, and 1075e, respectively, to allow each of these components to transmit and receive signals through their respective transceiver. At least one of transceivers 1075a, 1075b, 1075c, 1075d, and 1075e can include a receiver (e.g., receiver 120 of FIG. 1). The receiver can
15 include at least one of the comparators (e.g., at least one of comparators 105₀, 105₁, 105₂, and 105₃, 405, and 805) and the operations of the comparators described above with reference to FIG. 1 through FIG. 9.

[0092] The illustrations of apparatus (e.g., apparatus 100, 200, comparators 405 and 805, memory device 902, and system 1000) described
20 above with reference to FIG. 1 through FIG. 10 are intended to provide a general understanding of the structure of various embodiments and are not intended to provide a complete description of all the elements and features of apparatuses that might make use of the structures described herein.

[0093] The apparatus (e.g., apparatus 100, 200, comparators 405 and
25 805, memory device 902, and system 1000) described herein may include or be included in electronic circuitry, such as high-speed computers, communication and signal processing circuitry, single or multi-processor modules, single or multiple embedded processors, multi-core processors, message information switches, and application-specific modules including multilayer, multi-chip
30 modules. Such apparatuses may further be included as sub-components within a variety of other apparatuses (e.g., electronic systems), such as televisions, cellular telephones, personal computers (e.g., laptop computers, desktop computers, handheld computers, tablet computers, etc.), workstations, radios,

video players, audio players (e.g., MP3 (Motion Picture Experts Group, Audio Layer 5) players), vehicles, medical devices (e.g., heart monitor, blood pressure monitor, etc.), set top boxes, and others.

Additional Notes and Examples

5 [0094] Example 1 includes subject matter (such as a device, an electronic apparatus (e.g., circuit, electronic system, or both), or machine) including input nodes to receive input signals, output nodes to provide output signals, a first stage including a first pair of input transistors, the first pair of input transistors including gates coupled to the input nodes, a second stage including a second
10 pair of input transistors, the second pair of input transistors including gates coupled to the input nodes, and a third stage including inverters coupled to the output nodes, the inverters coupled to the first and second stages at same nodes to switch the output signals between different voltages based on the input signals.

15 [0095] In Example 2, the subject matter of Example 1 may optionally include a circuit coupled to the output nodes to provide first and second additional output signals based on the output signals.

[0096] In Example 3, the subject matter of Example 2 may optionally include, wherein the circuit includes a first logic gate and a second logic gate,
20 the first logic gate including a first input coupled to the second output node, a second input coupled to an output of the second logic gate, and an output coupled to a first input of the second logic gate, the second logic gate including a second input coupled to the first output node

[0097] In Example 4, the subject matter of Example 1 may optionally
25 include, wherein the second stage is arranged to receive a signal to deactivate the second stage during operation of the first and second stages.

[0098] In Example 5, the subject matter of Example 4 may optionally include, wherein the second stage is configured to assist the first stage to sample the input signals when a value of at least one of the input signals is less than one-
30 half of a value of an operating voltage of the third stage.

[0099] In Example 6, the subject matter of Example 5 may optionally include, wherein the second stage is configured to assist the first stage to sample

the input signals when a value of at least one of the input signals is greater than one-half of a value of an operating voltage of the third stage.

[00100] In Example 7, the subject matter of Example 1 may optionally include, wherein the input nodes, the output nodes, and the first, second, and
5 third stages are included in a device of the apparatus, the device including memory cells and data lines coupled to the input nodes, wherein one of the input signals has a value based on a value of a selected memory cell among the memory cells.

[00101] Example 8 includes subject matter (such as a device, an electronic
10 apparatus (e.g., circuit, electronic system, or both), or machine) including a first input node and a second input node, a first output node and second output node, a first plurality of transistors coupled between a first supply node and a second supply node, the first plurality of transistors including a first transistor and a second transistor coupled between the first output node and the second supply
15 node, a second plurality of transistors coupled between the first and second supply nodes, the second plurality of transistors including a third transistor and a fourth transistor coupled between the second output node and the second supply node, a first input transistor coupled between the second supply node and a node between the first and second transistors, the first input transistor including a gate
20 coupled to the first input node, and a second input transistor coupled between the second supply node and a node between the third and fourth transistors, the second input transistor including a gate coupled to the second input node.

[00102] In Example 9, the subject matter of Example 8 may optionally include a third input transistor coupled between the first and second supply
25 nodes, the third input transistor including a gate coupled to the first input node, and a fourth input transistor coupled between the first and second supply nodes, the fourth input transistor including a gate coupled to the second input node.

[00103] In Example 10, the subject matter of Example 9 may optionally include, wherein the first and second input transistors have a first transistor type
30 and the third and fourth input transistors have a second transistor type.

[00104] In Example 11, the subject matter of Example 10 may optionally include, wherein the first transistor type includes n-type and the second transistor type includes p-type.

[00105] In Example 12, the subject matter of Example 10 may optionally include, wherein the first transistor type includes p-type and the second transistor type includes n-type.

5 [00106] In Example 13, the subject matter of Example 8 may optionally include, wherein the first plurality of transistors includes a fifth transistor coupled between the first output node and the first supply node, and the second plurality of transistors includes a sixth transistor coupled between the second output node and the first supply node.

10 [00107] In Example 14, the subject matter of Example 13 may optionally include, wherein the first plurality of transistors includes a seventh transistor coupled between the first output node and the first supply node, and the second plurality of transistors includes an eighth transistor coupled between the second output node and the first supply node.

15 [00108] In Example 15, the subject matter of Example 8 may optionally include, wherein the first and second transistors of the first plurality of transistors and the third and fourth transistors of the second plurality of transistors have a same transistor type.

[00109] In Example 16, the subject matter of Example 8 may optionally include, wherein at least one of the first and second supply nodes is coupled to a
20 data line associated with a memory cell.

[00110] Example 17 includes subject matter (such as a device, an electronic apparatus (e.g., circuit, electronic system, or both), or machine) including a first node included in a first device to receive a first signal provided from a second device, a second node included in the first device to receive a
25 second input signal generated by the first device, and a receiver included in the first device, the receiver including a comparator coupled to the first and second nodes, the comparator including output nodes to provide output signals, a first stage including a first pair of input transistors, the first pair of input transistors including gates coupled to the input nodes, a second stage including a second
30 pair of input transistors, the second pair of input transistors including gates coupled to the input nodes, and a third stage including inverters coupled to the output nodes, the inverters coupled to the first and second stages at same nodes

to switch the output signals between different voltages based on the input signals.

[00111] In Example 18, the subject matter of Example 17 may optionally include, wherein the first node is part of one of a solder ball, a solder bump, and
5 a pin.

[00112] In Example 19, the subject matter of Example 17 may optionally include, wherein the first node is arranged to couple to a conductive path on a circuit board.

[00113] In Example 20, the subject matter of Example 17 may optionally
10 include, wherein the first device is included in a first die, and the second device is included in a second die.

[00114] The above description and the drawings illustrate some embodiments to enable those skilled in the art to practice the embodiments of the invention. Other embodiments may incorporate structural, logical, electrical,
15 process, and other changes. Examples merely typify possible variations. Portions and features of some embodiments may be included in, or substituted for, those of other embodiments. Many other embodiments will be apparent to those of skill in the art upon reading and understanding the above description. Therefore, the scope of various embodiments is determined by the appended
20 claims, along with the full range of equivalents to which such claims are entitled.

[00115] The Abstract is provided to allow the reader to ascertain the nature and gist of the technical disclosure. It is submitted with the understanding that it will not be used to limit or interpret the scope or meaning of the claims. The following claims are hereby incorporated into the detailed description, with
25 each claim standing on its own as a separate embodiment.

CLAIMS

What is claimed is:

1. An apparatus comprising:
input nodes to receive input signals;
5 output nodes to provide output signals;
a first stage including a first pair of input transistors, the first pair of
input transistors including gates coupled to the input nodes;
a second stage including a second pair of input transistors, the second
pair of input transistors including gates coupled to the input nodes; and
10 a third stage including inverters coupled to the output nodes, the inverters
coupled to the first and second stages at same nodes to switch the output signals
between different voltages based on the input signals.
2. The apparatus of claim 1, further comprising a circuit coupled to the
15 output nodes to provide first and second additional output signals based on the
output signals.
3. The apparatus of claim 2, wherein the circuit includes a first logic gate
and a second logic gate, the first logic gate including a first input coupled to a
20 first output node of the output nodes, a second input coupled to an output of the
second logic gate, and an output coupled to a first input of the second logic gate,
the second logic gate including a second input coupled to a second output node
of the output nodes.
- 25 4. The apparatus of any of claims 1-3, wherein the second stage is arranged
to receive a signal to deactivate the second stage during operation of the first and
second stages.
5. The apparatus of claim 4, wherein the second stage is configured to assist
30 the first stage to sample the input signals when a value of at least one of the
input signals is less than one-half of a value of an operating voltage of the third
stage.

6. The apparatus of claim 5, wherein the second stage is configured to assist the first stage to sample the input signals when a value of at least one of the input signals is greater than one-half of a value of an operating voltage of the
5 third stage.

7. The apparatus of claim 1, wherein the input nodes, the output nodes, and the first, second, and third stages are included in a device of the apparatus, the
10 device including memory cells and data lines coupled to the input nodes, wherein one of the input signals has a value based on a value of a selected memory cell among the memory cells.

8. An apparatus comprising:
15 a first input node and a second input node;
a first output node and a second output node;
a first plurality of transistors coupled between a first supply node and a second supply node, the first plurality of transistors including a first transistor and a second transistor coupled between the first output node and the second
20 supply node;
a second plurality of transistors coupled between the first and second supply nodes, the second plurality of transistors including a third transistor and a fourth transistor coupled between the second output node and the second supply node;
25 a first input transistor coupled between the second supply node and a node between the first and second transistors, the first input transistor including a gate coupled to the first input node; and
a second input transistor coupled between the second supply node and a node between the third and fourth transistors, the second input transistor
30 including a gate coupled to the second input node.

9. The apparatus of claim 8, further comprising:
a third input transistor coupled between the first and second supply nodes, the third input transistor including a gate coupled to the first input node;
and
5 a fourth input transistor coupled between the first and second supply nodes, the fourth input transistor including a gate coupled to the second input node.
10. The apparatus of claim 9, wherein the first and second input transistors
10 have a first transistor type and the third and fourth input transistors have a second transistor type.
11. The apparatus of claim 10, wherein the first transistor type includes n-type and the second transistor type includes p-type.
15
12. The apparatus of claim 10, wherein the first transistor type includes p-type and the second transistor type includes n-type.
13. The apparatus of claim 8, wherein the first plurality of transistors
20 includes a fifth transistor coupled between the first output node and the first supply node, and the second plurality of transistors includes a sixth transistor coupled between the second output node and the first supply node.
14. The apparatus of claim 13, wherein the first plurality of transistors
25 includes a seventh transistor coupled between the first output node and the first supply node, and the second plurality of transistors includes an eighth transistor coupled between the second output node and the first supply node.
15. The apparatus of claim 8, wherein the first and second transistors of the
30 first plurality of transistors and the third and fourth transistors of the second plurality of transistors have a same transistor type.

16. The apparatus of claim 8, wherein at least one of the first and second input nodes is coupled to a data line associated with a memory cell.

- 5 17. An apparatus comprising:
- a first node included in a first device to receive a first signal provided from a second device;
 - a second node included in the first device to receive a second input signal generated by the first device; and
 - 10 a receiver included in the first device, the receiver including a comparator coupled to the first and second nodes, the comparator including:
 - output nodes to provide output signals;
 - a first stage including a first pair of input transistors, the first pair of input transistors including gates coupled to the input nodes;
 - 15 a second stage including a second pair of input transistors, the second pair of input transistors including gates coupled to the input nodes; and
 - a third stage including inverters coupled to the output nodes, the inverters coupled to the first and second stages at same nodes to switch the output signals between different voltages based on the input signals.

20

18. The apparatus of claim 17, wherein the first node is part of one of a solder ball, a solder bump, and a pin.

19. The apparatus of claim 17, wherein the first node is arranged to couple to
25 a conductive path on a circuit board.

20. The apparatus of claim 17, wherein the first device is included in a first die, and the second device is included in a second die.

30

21. A method of operating an electronic apparatus, the method comprising:
receiving input signals at gates of a first pair of input transistors of a first
stage of a device;
receiving the input signals at gates of a second pair of input transistors of
5 a second stage in the device; and
generating output signals at inverters of a third stage of the device, the
inverters coupled to the first and second stages at same nodes such that output
signals switch between different voltages based on the input signals.
- 10 22. The method of claim 21, wherein one of the input signals includes a
single-ended signal.
23. The method of claim 21, wherein the input signals include differential
signals.
- 15 24. The method of claim 21 or 22, wherein the first and second pairs of
transistors and the inverters are included in a die of the device, a first input
signal of the input signals is generated by the device, and a second input signal
of the input signals is generated by an additional device, the additional device
20 including an additional die.
- 25 25. The method of claim 21 or 23, wherein the first and second pairs of
transistors and the inverters are included in a die of the device, and the input
signals are provided to the device by an additional device, the additional device
25 including an additional die.

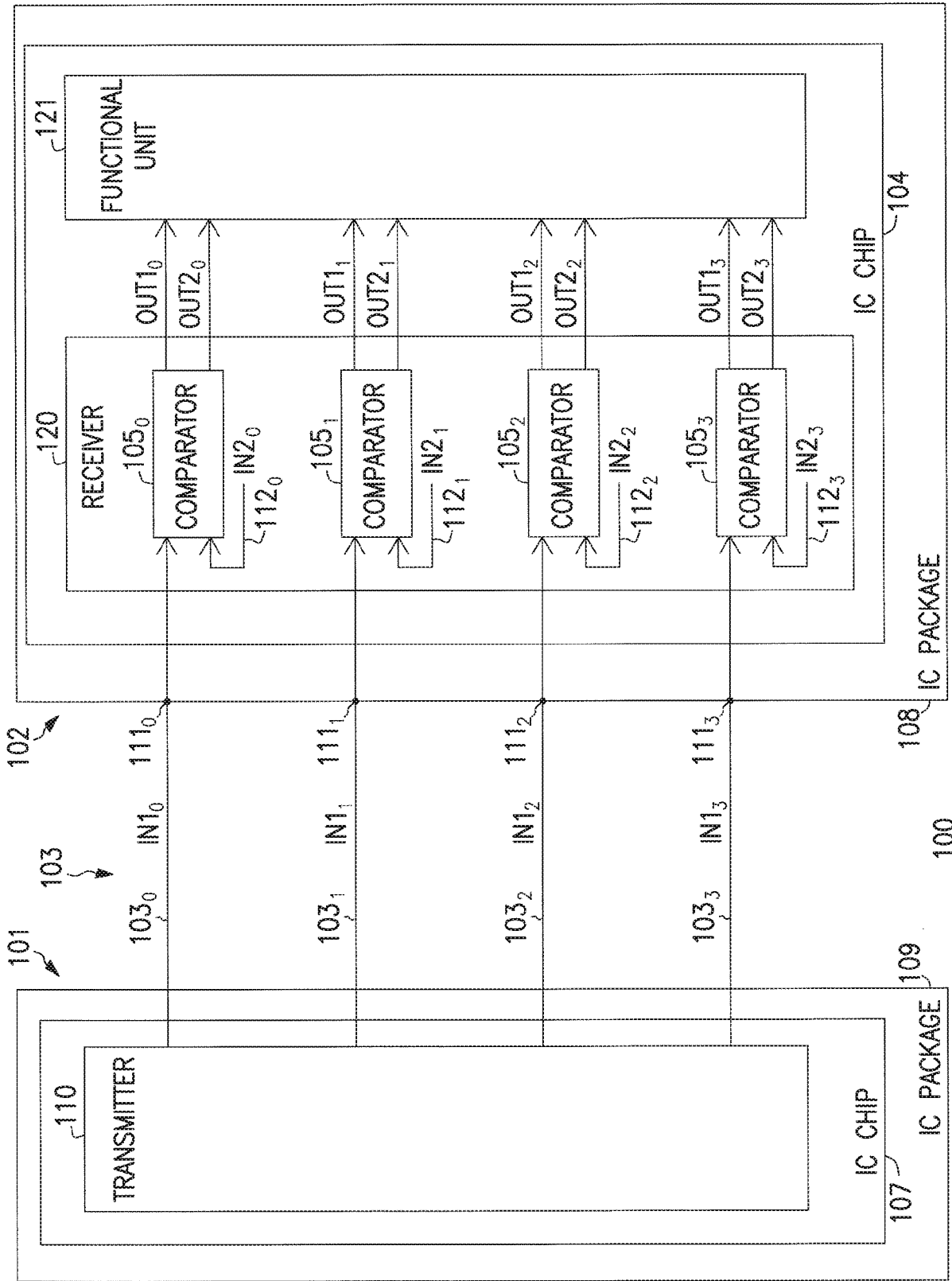

FIG. 1

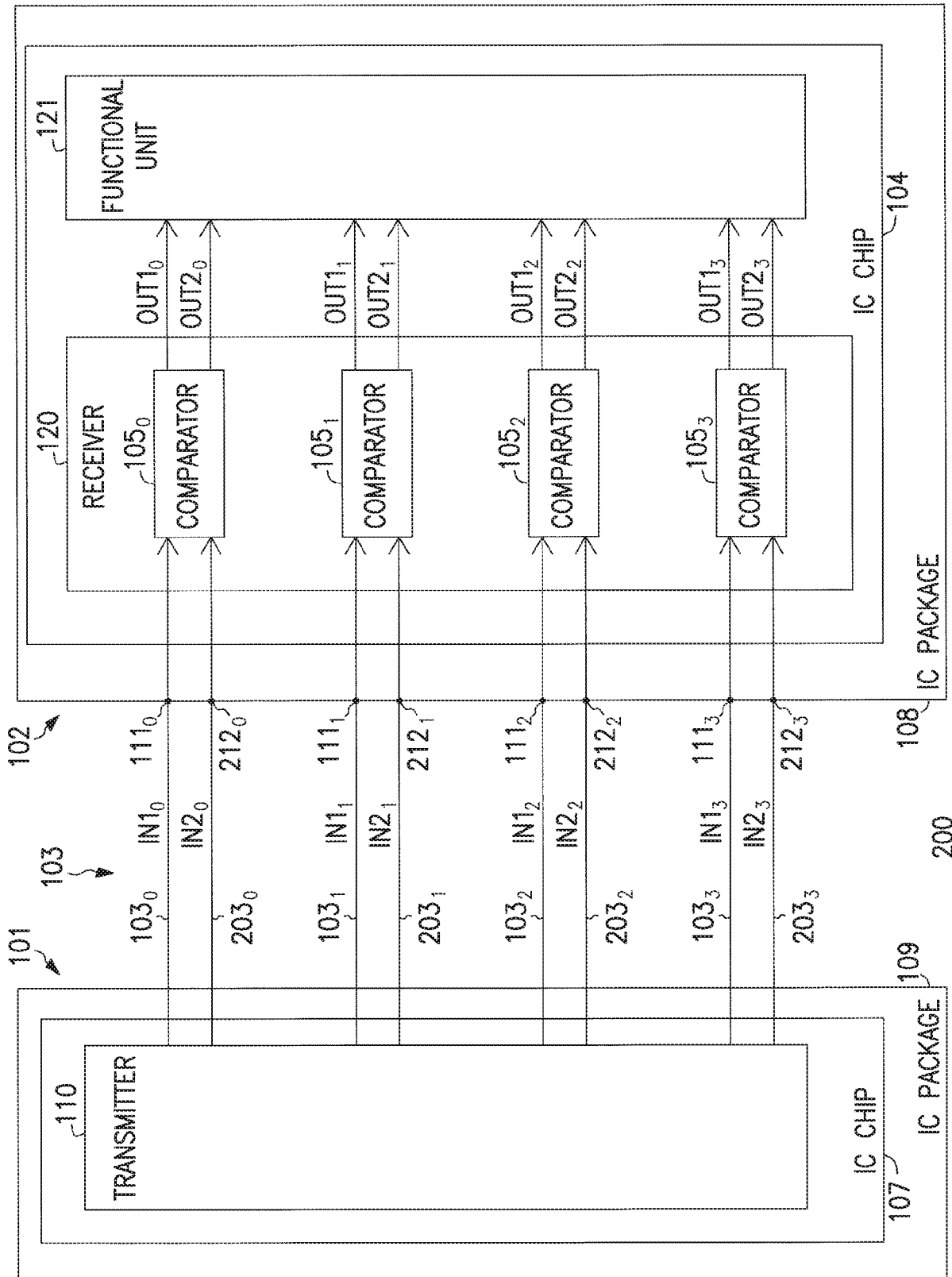

FIG. 2

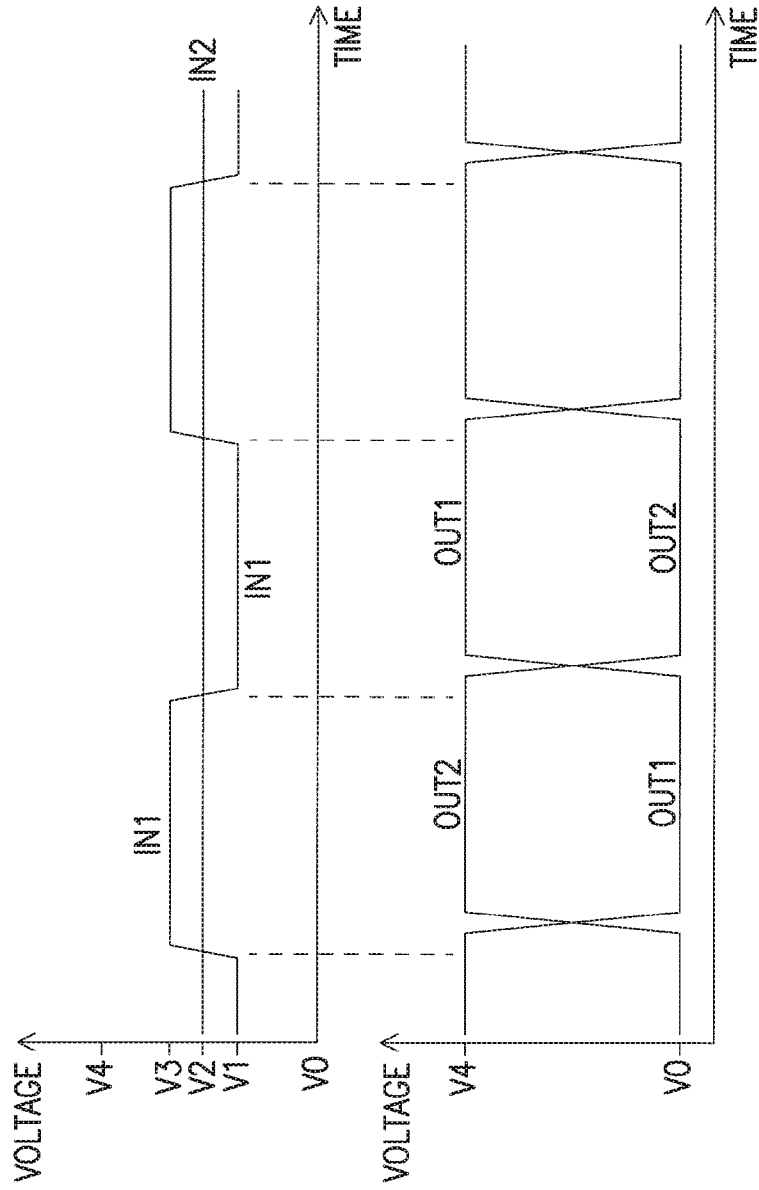

FIG. 3A

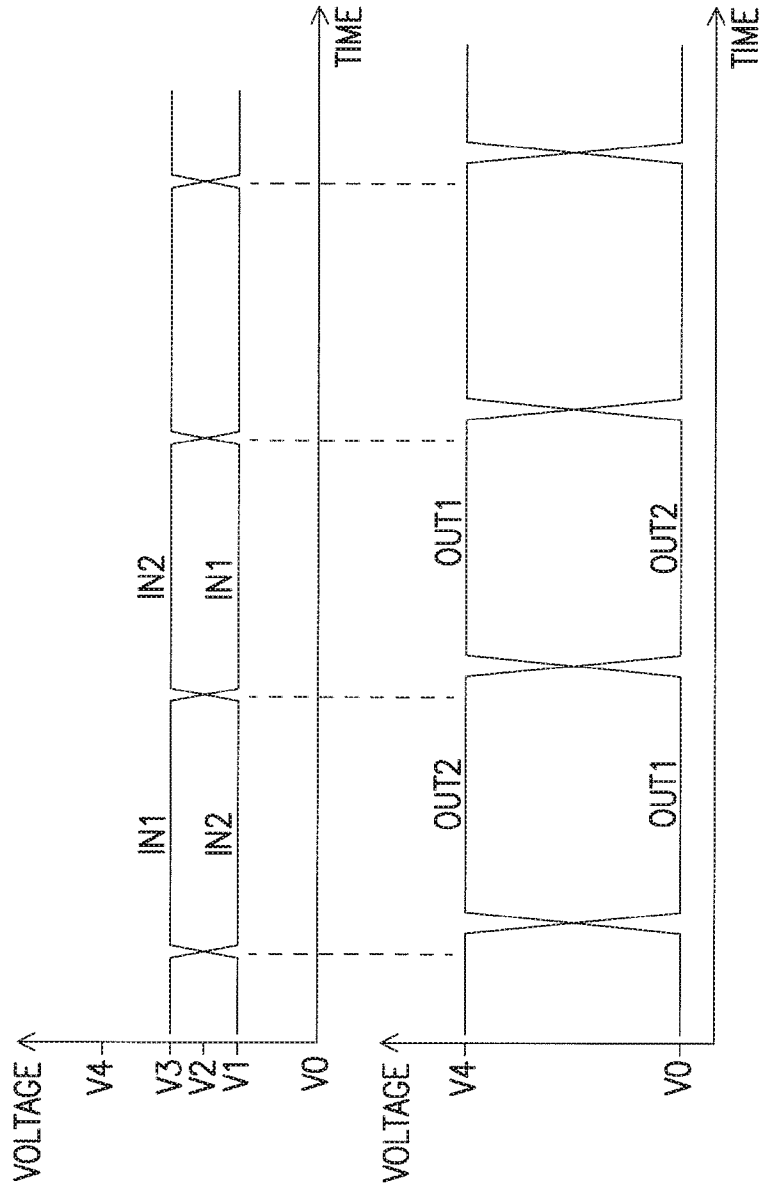
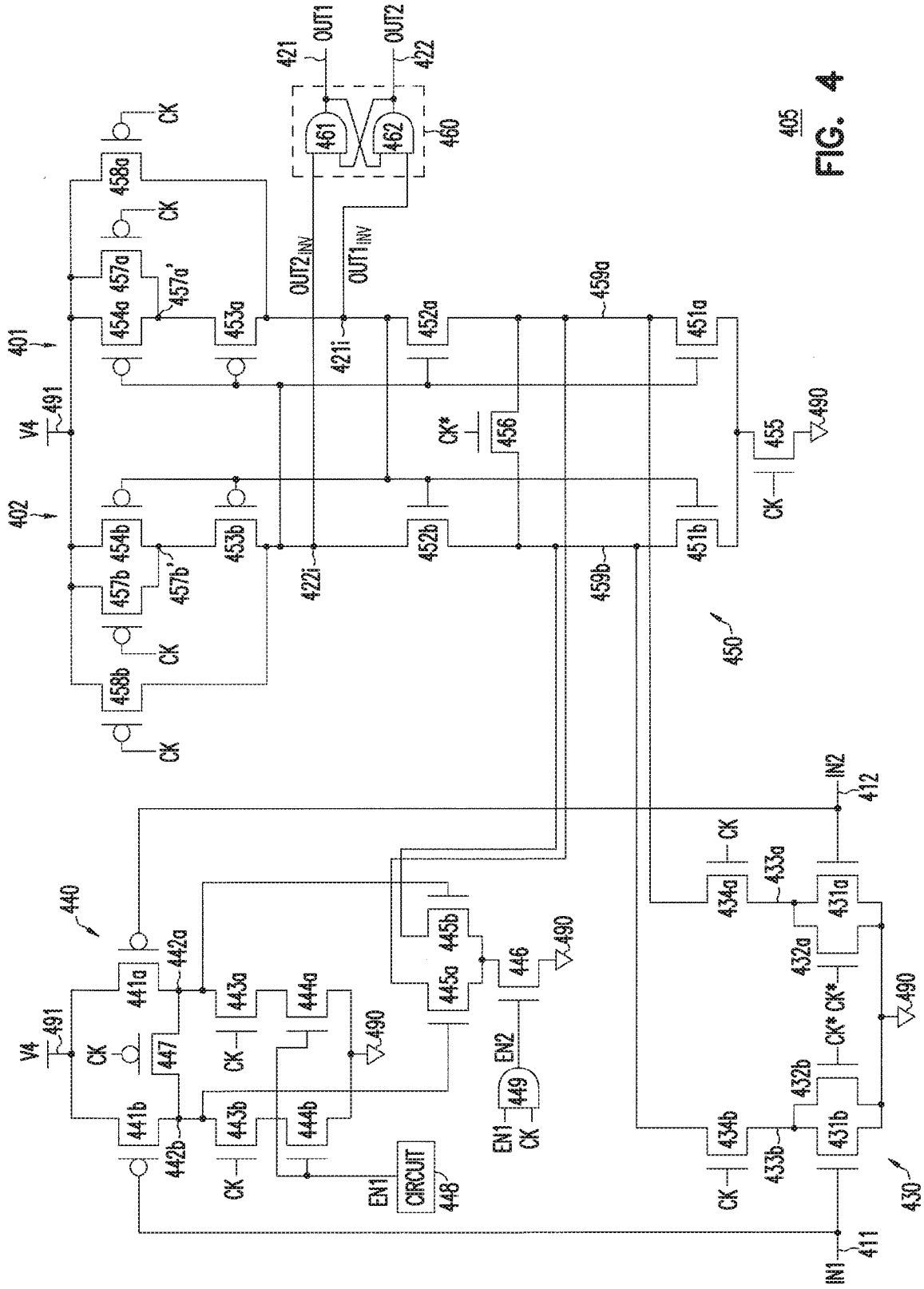

FIG. 3B



405
FIG. 4

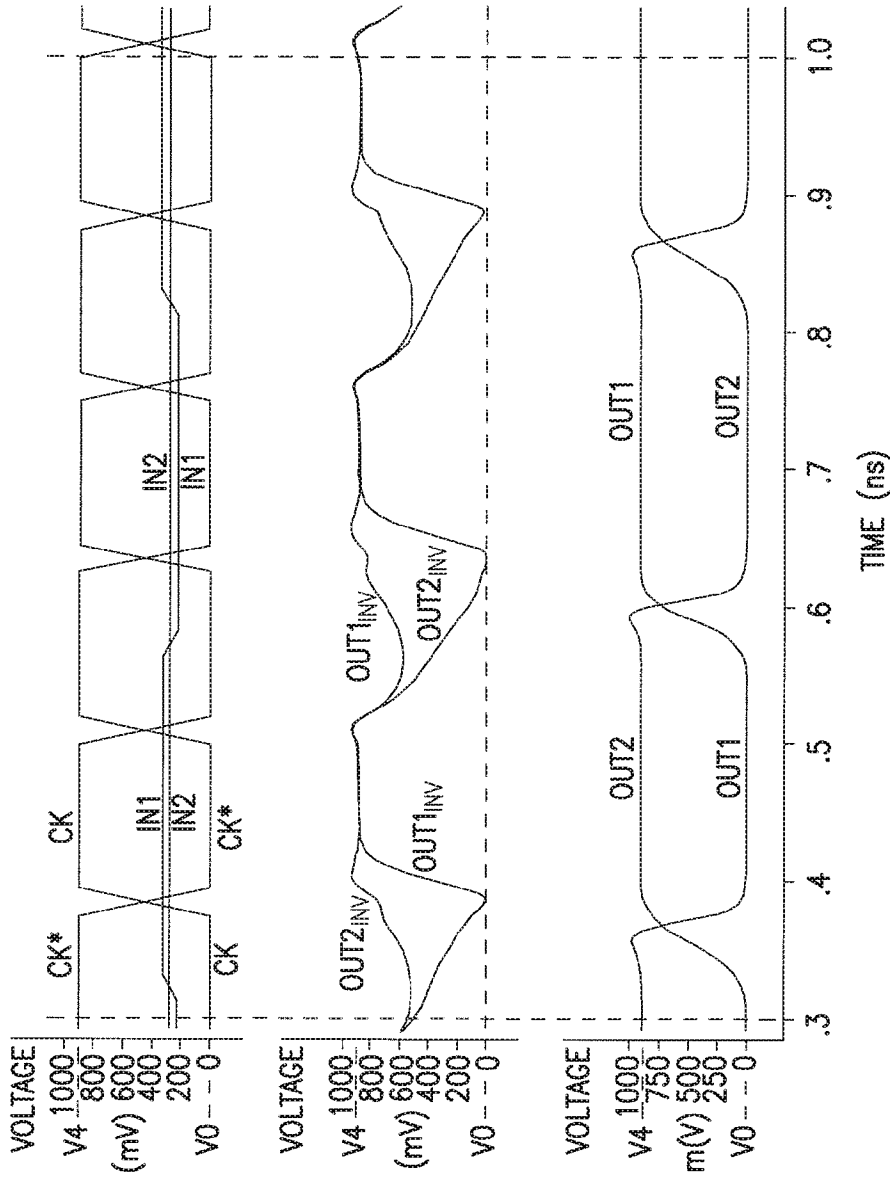

FIG. 5

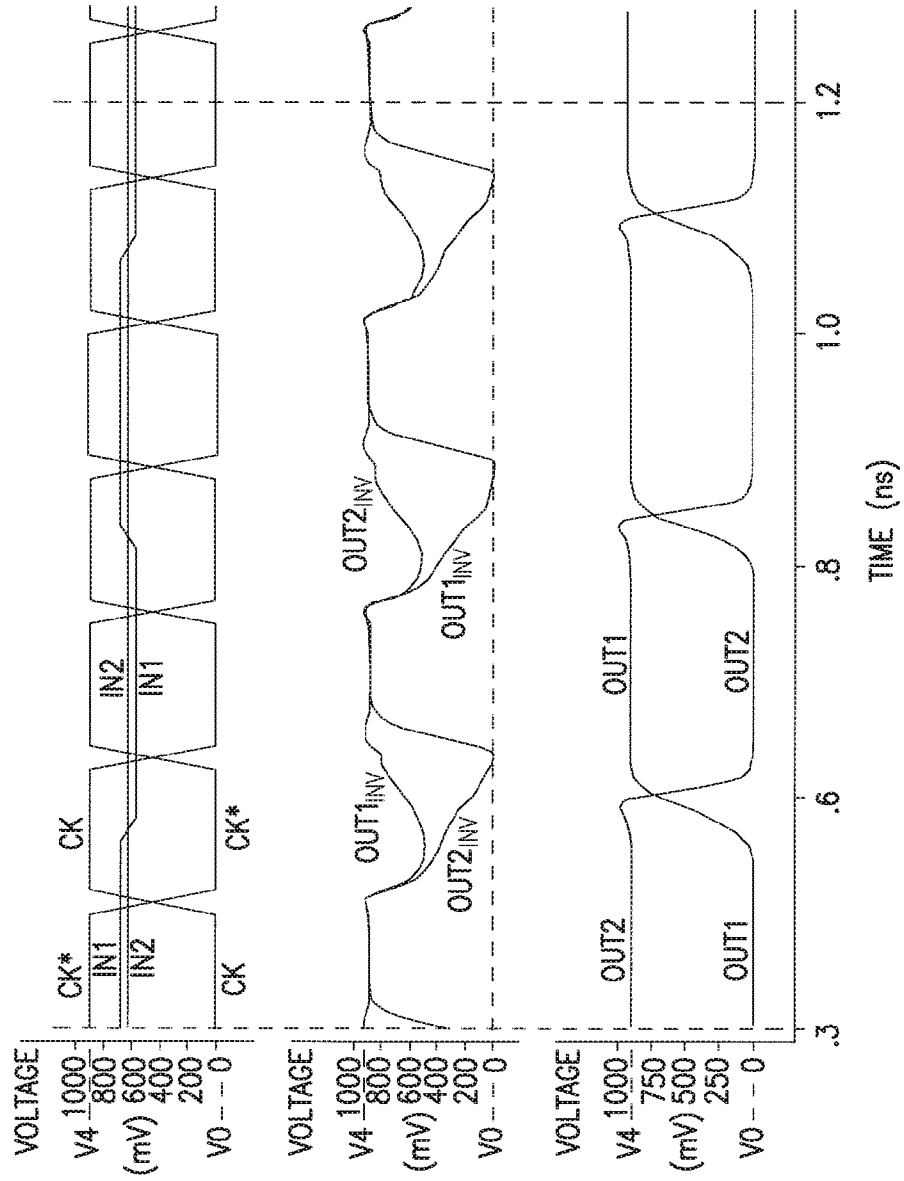

FIG. 6

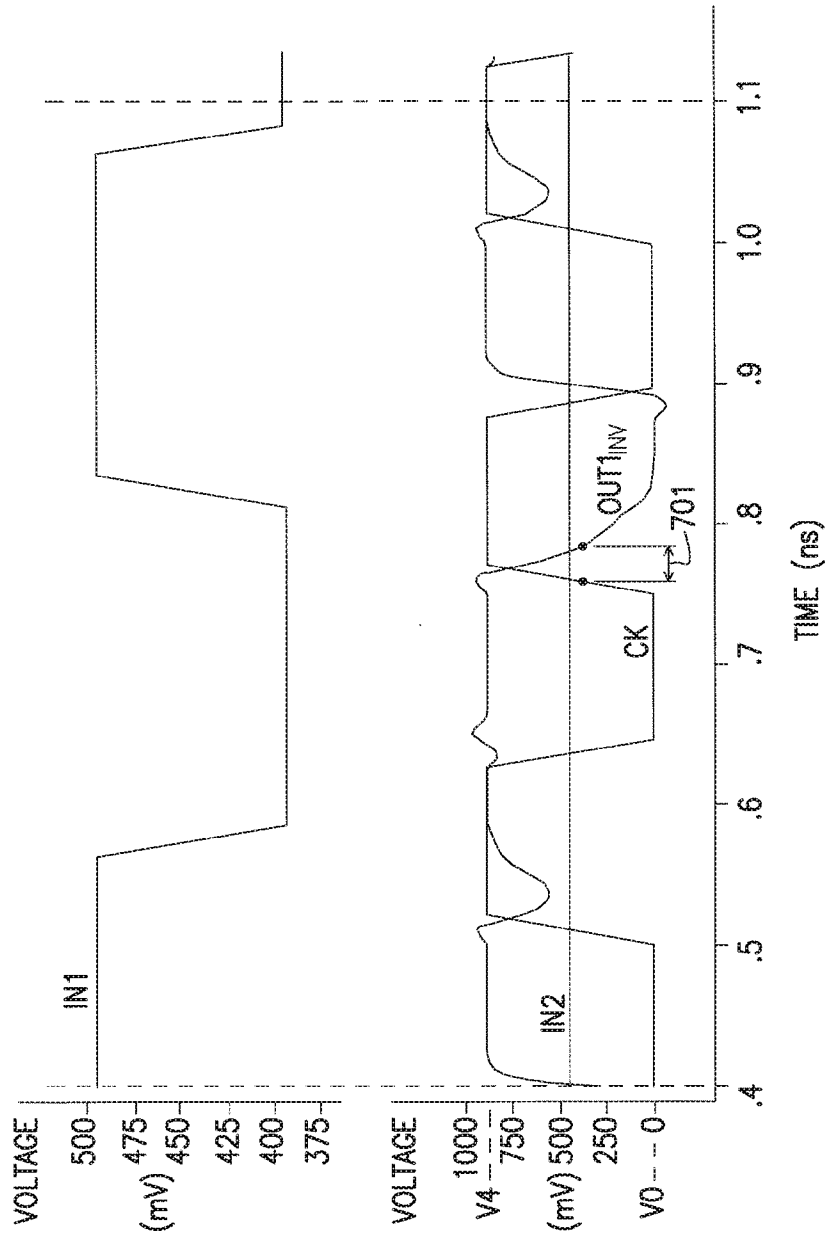
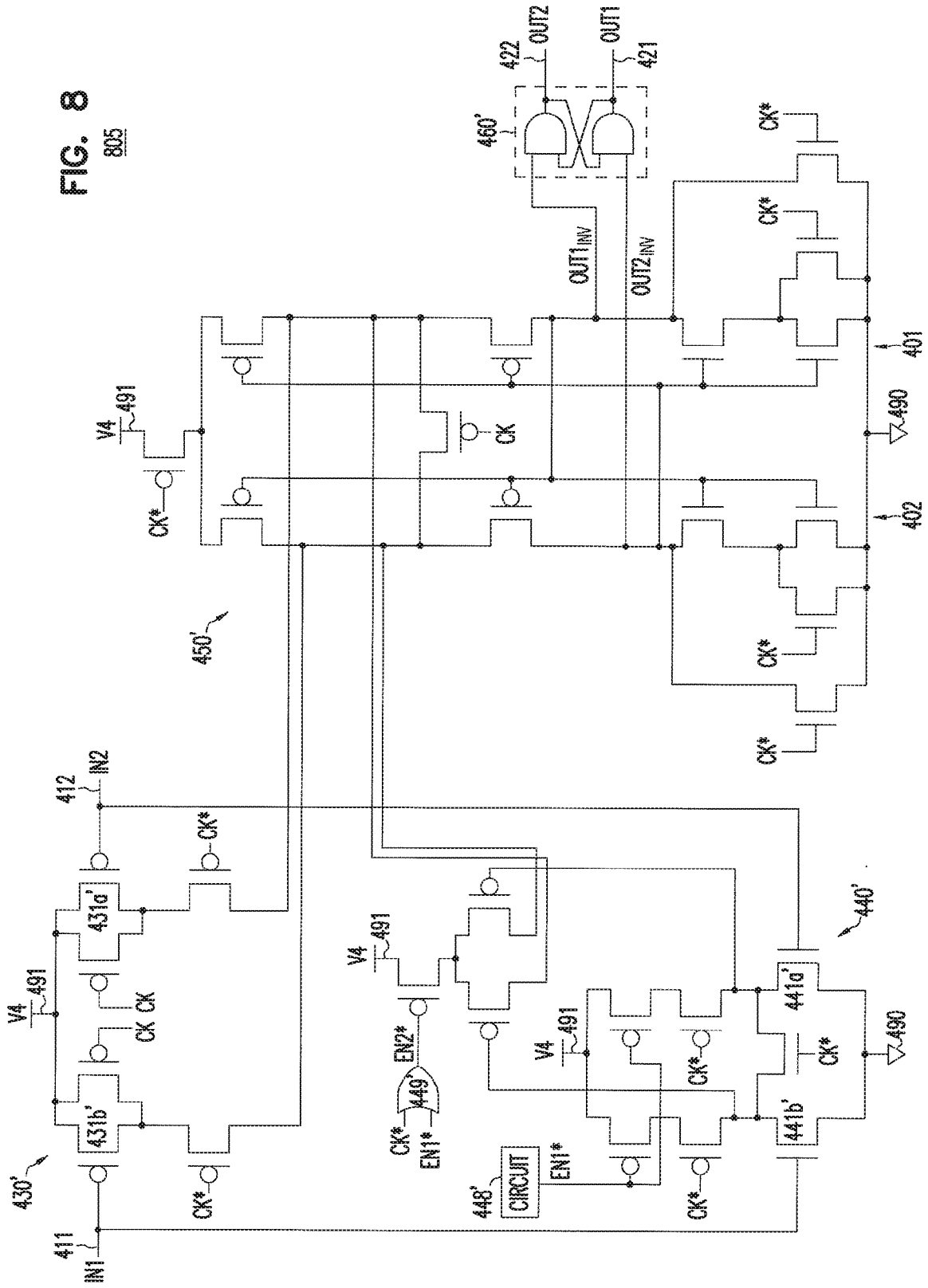
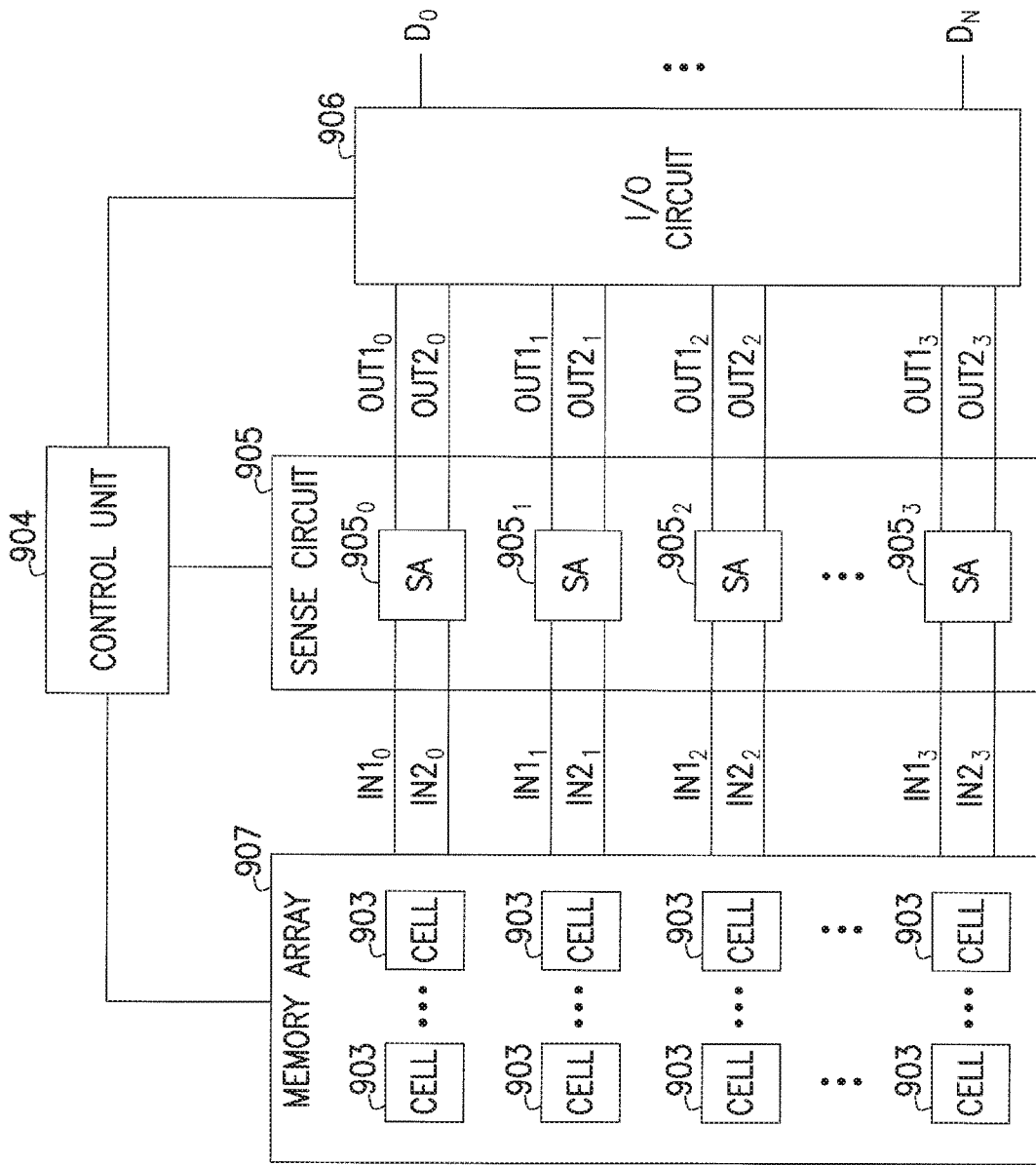

FIG. 7

FIG. 8

805





902
FIG. 9

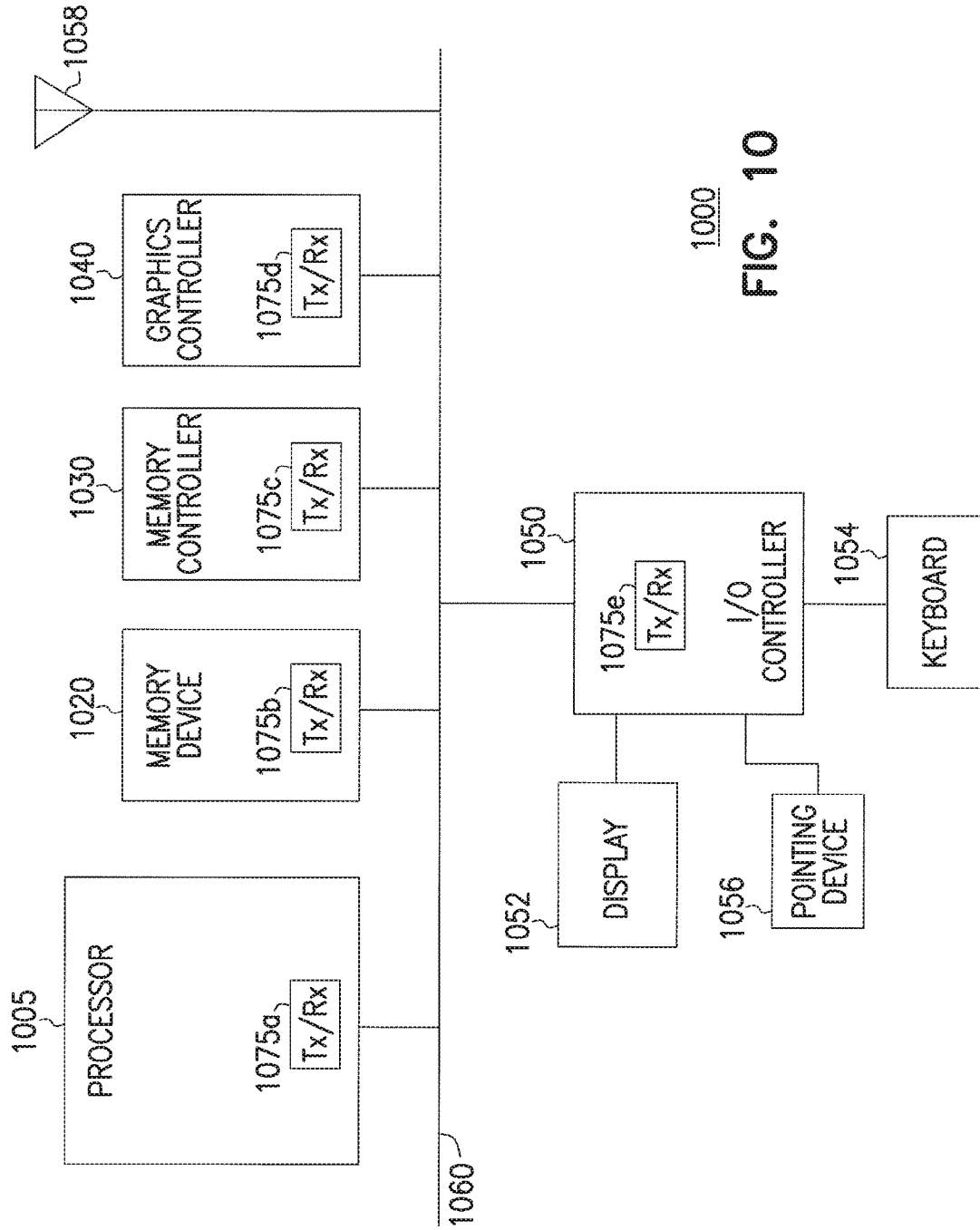

1000
FIG. 10

A. CLASSIFICATION OF SUBJECT MATTER**H03K 3/288(2006.01)I, H03K 3/356(2006.01)I**

According to International Patent Classification (IPC) or to both national classification and IPC

B. FIELDS SEARCHED

Minimum documentation searched (classification system followed by classification symbols)

H03K 3/288; H04L 27/00; H03K 5/00; H03L 5/00; H03K 5/22; G01R 19/00; G09G 5/00; H03K 3/356

Documentation searched other than minimum documentation to the extent that such documents are included in the fields searched

Korean utility models and applications for utility models

Japanese utility models and applications for utility models

Electronic data base consulted during the international search (name of data base and, where practicable, search terms used)

eKOMPASS(KIPO internal) & Keywords: receiver, input signal, output signal, stage, transistor, inverter

C. DOCUMENTS CONSIDERED TO BE RELEVANT

Category*	Citation of document, with indication, where appropriate, of the relevant passages	Relevant to claim No.
X	US 2011-0115529 A1 (CHRISTER JANSSON) 19 May 2011 See paragraphs [0041]-[0048], [0060]-[0064], [0069]-[0075], [0082]-[0084], [0096], claims 1, 22 and figures 1, 3a, 4a, 6.	1-17, 21-24
Y		18-20, 25
Y	US 05504782 A (JULES D. CAMPBELL, JR.) 02 April 1996 See column 7, lines 58-60, claim 1 and figures 1-2.	18-19
Y	US 2005-0088218 A1 (YUKINARI SHIBATA et al.) 28 April 2005 See paragraph [0183], claim 1 and figures 1-3, 14.	20, 25
A	US 2004-0239662 A1 (AKIO HOSOKAWA et al.) 02 December 2004 See paragraphs [0054]-[0065], claim 1 and figure 6.	1-25
A	US 2004-0230388 A1 (YONG-JUN KIM et al.) 18 November 2004 See paragraphs [0017]-[0019], [0022] and figures 1, 4.	1-25

 Further documents are listed in the continuation of Box C. See patent family annex.

* Special categories of cited documents:

"A" document defining the general state of the art which is not considered to be of particular relevance

"E" earlier application or patent but published on or after the international filing date

"L" document which may throw doubts on priority claim(s) or which is cited to establish the publication date of another citation or other special reason (as specified)

"O" document referring to an oral disclosure, use, exhibition or other means

"P" document published prior to the international filing date but later than the priority date claimed

"T" later document published after the international filing date or priority date and not in conflict with the application but cited to understand the principle or theory underlying the invention

"X" document of particular relevance; the claimed invention cannot be considered novel or cannot be considered to involve an inventive step when the document is taken alone

"Y" document of particular relevance; the claimed invention cannot be considered to involve an inventive step when the document is combined with one or more other such documents, such combination being obvious to a person skilled in the art

"&" document member of the same patent family

Date of the actual completion of the international search

12 September 2016 (12.09.2016)

Date of mailing of the international search report

12 September 2016 (12.09.2016)

Name and mailing address of the ISA/KR

International Application Division

Korean Intellectual Property Office

189 Cheongsa-ro, Seo-gu, Daejeon, 35208, Republic of Korea

Facsimile No. +82-42-481-8578

Authorized officer

CHO, KI YUN

Telephone No. +82-42-481-5655



INTERNATIONAL SEARCH REPORT

Information on patent family members

International application No.

PCT/US2016/035525

Patent document cited in search report	Publication date	Patent family member(s)	Publication date
US 2011-0115529 A1	19/05/2011	US 8319526 B2	27/11/2012
US 05504782 A	02/04/1996	None	
US 2005-0088218 A1	28/04/2005	CN 100337403 C CN 100566165 C CN 100583850 C CN 1771662 A CN 1778046 A CN 1778081 A EP 1662657 A1 EP 1662657 A4 EP 1662657 B1 EP 1662658 A1 EP 1662658 B1 EP 1662734 A1 EP 1662734 B1 JP 2005-236929 A JP 2005-236930 A JP 2005-236931 A JP 3807406 B2 JP 3807407 B2 JP 3891185 B2 KR 10-0647185 B1 KR 10-0647186 B1 KR 10-0716687 B1 KR 10-2006-0035590 A US 2005-0066077 A1 US 2006-0097753 A1 US 2007-0182452 A1 US 2008-0022144 A1 US 7218146 B2 US 7249271 B2 US 7298172 B2 US 7535257 B2 US 7984321 B2 WO 2005-025066 A1 WO 2005-025067 A1 WO 2005-025163 A1	12/09/2007 02/12/2009 20/01/2010 10/05/2006 24/05/2006 24/05/2006 31/05/2006 03/01/2007 18/02/2009 31/05/2006 02/06/2010 31/05/2006 09/03/2016 02/09/2005 02/09/2005 02/09/2005 09/08/2006 09/08/2006 14/03/2007 23/11/2006 23/11/2006 09/05/2007 26/04/2006 24/03/2005 11/05/2006 09/08/2007 24/01/2008 15/05/2007 24/07/2007 20/11/2007 19/05/2009 19/07/2011 17/03/2005 17/03/2005 17/03/2005
US 2004-0239662 A1	02/12/2004	JP 2004-317910 A JP 4327493 B2 KR 10-0542930 B1 KR 10-2004-0090902 A TW 200425640 A TW 235551 A US 7394292 B2	11/11/2004 09/09/2009 11/01/2006 27/10/2004 16/11/2004 01/07/2005 01/07/2008
US 2004-0230388 A1	18/11/2004	KR 10-0518573 B1	04/10/2005

INTERNATIONAL SEARCH REPORT

Information on patent family members

International application No.

PCT/US2016/035525

Patent document cited in search report	Publication date	Patent family member(s)	Publication date
		KR 10-2004-0098690 A TW I249301 B US 7123058 B2	26/11/2004 11/02/2006 17/10/2006