

(19) World Intellectual Property Organization
International Bureau



(43) International Publication Date
22 November 2001 (22.11.2001)

PCT

(10) International Publication Number
WO 01/87372 A1

- (51) International Patent Classification⁷: **A61L 31/16**
- (21) International Application Number: PCT/US01/13780
- (22) International Filing Date: 25 April 2001 (25.04.2001)
- (25) Filing Language: English
- (26) Publication Language: English
- (30) Priority Data:
60/204,417 12 May 2000 (12.05.2000) US
60/575,480 19 May 2000 (19.05.2000) US
- (71) Applicant: **CORDIS CORPORATION** [US/US]; 14201 N.W. 60th Avenue, Miami Lakes, FL 33014 (US).
- (72) Inventors: **KOPIA, Gregory, A.**; 58 Longfellow Drive, Neshanic, NJ 08853 (US). **LLANOS, Gerald, H.**; 1514 Megan Circle, Stewartville, NJ 08886 (US). **FALOTICO, Robert, F.**; 40 Black Horse Run, Belle Mead, NJ 08502 (US).
- (74) Agents: **JOHNSON, Philip, S.** et al.; Johnson & Johnson, 1 Johnson & Johnson Plaza, New Brunswick, NJ 08933-7003 (US).
- (81) Designated States (*national*): AE, AG, AL, AM, AT, AU, AZ, BA, BB, BG, BR, BY, BZ, CA, CH, CN, CR, CU, CZ, DE, DK, DM, DZ, EE, ES, FI, GB, GD, GE, GH, GM, HR, HU, ID, IL, IN, IS, JP, KE, KG, KP, KR, KZ, LC, LK, LR, LS, LT, LU, LV, MA, MD, MG, MK, MN, MW, MX, MZ, NO, NZ, PL, PT, RO, RU, SD, SE, SG, SI, SK, SL, TJ, TM, TR, TT, TZ, UA, UG, UZ, VN, YU, ZA, ZW.
- (84) Designated States (*regional*): ARIPO patent (GH, GM, KE, LS, MW, MZ, SD, SL, SZ, TZ, UG, ZW), Eurasian patent (AM, AZ, BY, KG, KZ, MD, RU, TJ, TM), European patent (AT, BE, CH, CY, DE, DK, ES, FI, FR, GB, GR, IE, IT, LU, MC, NL, PT, SE, TR), OAPI patent (BF, BJ, CF, CG, CI, CM, GA, GN, GW, ML, MR, NE, SN, TD, TG).
- Published:**
— with international search report
— before the expiration of the time limit for amending the claims and to be republished in the event of receipt of amendments

[Continued on next page]

(54) Title: DRUG COMBINATIONS USEFUL FOR PREVENTION OF RESTENOSIS

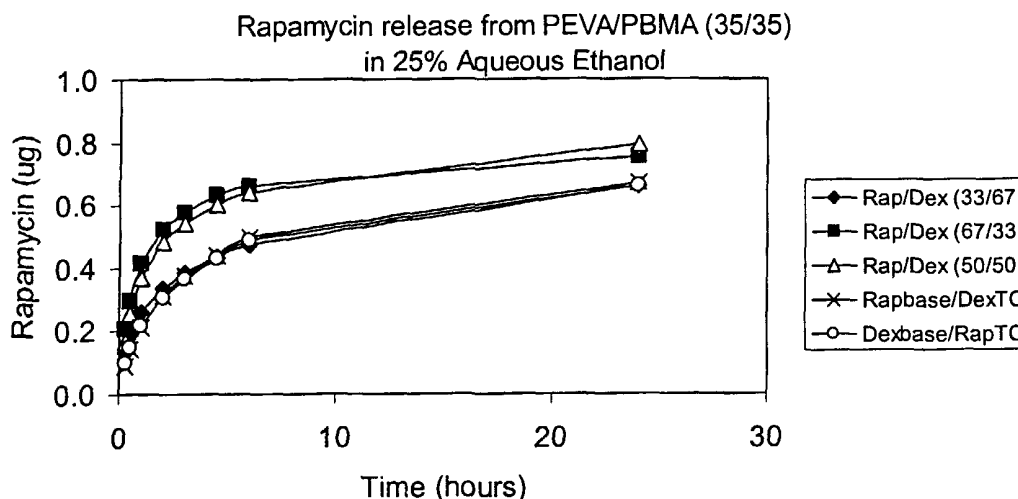

(57) Abstract: The current invention comprises an approach to solving the clinical problem of restenosis, which involves the administration of combinations of drugs to patients undergoing PTCA or stent implantation. In one embodiment of the invention, an antiproliferative agent such as rapamycin, vincristine or taxol is administered in combination with the antiinflammatory agent, dexamethasone, to patients systemically, either subcutaneously or intravenously. In another embodiment of the invention, the antiproliferative and antiinflammatory agents are bound in a single formulation to the surface of a stent by means of incorporation within either a biodegradable or biostable polymeric coating. Alternatively, such drug combinations could be incorporated into a stent constructed with a grooved reservoir.

WO 01/87372 A1



For two-letter codes and other abbreviations, refer to the "Guidance Notes on Codes and Abbreviations" appearing at the beginning of each regular issue of the PCT Gazette.

5

DRUG COMBINATIONS USEFUL FOR PREVENTION OF RESTENOSIS**Related Application:**

10

This application claims benefit of a provisional application of the same title, S.N. 60/204,417, filed May 12, 2000.

Field of the Invention:

15

This invention describes the delivery of different drug combinations, either systemically or locally, particularly from an intravascular stent, directly from micropores in the stent body or mixed or bound to a polymer coating applied on stent, to inhibit neointimal tissue proliferation and thereby prevent restenosis. This invention given either systemically or locally also facilitates the performance of the stent in inhibiting restenosis.

20

BACKGROUND OF THE INVENTION

25

30

Atherosclerotic lesions, which limit or obstruct coronary blood flow, are the major cause of ischemic heart disease related mortality, resulting in 500,000-600,000 deaths annually. Percutaneous transluminal coronary angioplasty (PTCA) to open the obstructed artery was performed in over 550,000 patients in the U.S. and 945,000+ patients worldwide in 1996 (Lemaitre et al., 1996). A major limitation of this technique is the problem of post-PTCA closure of the vessel, both immediately after PTCA (acute occlusion) and in the long term (restenosis): 30% of patients with subtotal lesions and 50% of patients with chronic total lesions will go on to restenosis after angioplasty. Additionally, restenosis is a significant problem in patients undergoing saphenous vein bypass graft. The mechanism of acute occlusion appears to involve several factors and may result from vascular recoil with resultant closure of the artery

5 and/or deposition of blood platelets along the damaged length of the newly opened blood vessel followed by formation of a fibrin/red blood cell thrombus.

10 Restenosis after angioplasty is a more gradual process and involves initial formation of a subcritical thrombosis with release from adherent platelets of cell derived growth factors with subsequent proliferation of intimal smooth muscle cells and local infiltration of inflammatory cells contributing to vascular hyperplasia. It is important to note that multiple processes, among those including thrombosis, cell proliferation, cell migration and inflammation each seem to contribute to the restenotic process.

15 In the U.S., a 30 - 50% restenosis rate translates to 120,000 - 200,000 U.S. patients at risk from restenosis. If only 80% of such patients elect repeat angioplasty (with the remaining 20% electing coronary artery bypass graft) is added to the cost of coronary artery bypass graft for the remaining 20%, the total cost for restenosis easily reaches into billions of dollars. Thus, successful prevention of restenosis could result not only in significant therapeutic benefit but also in significant health care savings.

25 While the exact mechanism for restenosis is still uncertain, the general aspects of the restenosis process have been identified:

30 1) In the normal arterial wall, smooth muscle cells (SMC) proliferate at a low rate (<0.1%/day). SMC in vessel wall exists in a 'contractile' phenotype characterized by 80-90% of the cell cytoplasmic volume occupied with the contractile apparatus. Endoplasmic reticulum, Golgi, and free ribosomes are few and located in the perinuclear region. Extracellular matrix surrounds SMC and is rich in heparin-like glycosylaminoglycans which are believed to be responsible for maintaining SMC in the contractile phenotypic state (Campbell and Campbell, 1985).

35

- 5 2) Upon pressure expansion of an intracoronary balloon catheter during angioplasty, smooth muscle cells within the arterial wall become injured, initiating a thrombotic and inflammatory response. Cell derived growth factors such as platelet derived growth factor (PDGF), basic fibroblast growth factor (bFGF), epidermal growth factor (EGF), thrombin, etc.,
10 released from platelets (i.e., PDGF) adhering to the damaged arterial luminal surface, invading macrophages and/or leukocytes, or directly from SMC (i.e., bFGF) provoke a proliferation and migratory response in medial SMC. These cells undergo a phenotypic change from the contractile phenotype to a 'synthetic' phenotype characterized by only few contractile
15 filament bundles but extensive rough endoplasmic reticulum, Golgi and free ribosomes. Proliferation/migration usually begins within 1-2 days post-injury and peaks at 2 days in the media, declining thereafter (Campbell and Campbell, 1987; Clowes and Schwartz, 1985).
- 20 3) Daughter synthetic cells migrate to the intimal layer of arterial smooth muscle and continue to proliferate and begin to secrete significant amounts of extracellular matrix proteins. Proliferation, migration and inflammation continue until the damaged luminal endothelial layer regenerates at which time proliferation slows within the intima, usually within 7-14 days
25 postinjury. The further increase in intimal thickening that occurs over the next 3-6 months is due primarily to an increase in extracellular matrix rather than cell number. Thus, SMC migration and proliferation is an acute response to vessel injury while intimal hyperplasia is a more chronic response. (Liu *et al.*, 1989).
- 30 4) Simultaneous with local proliferation and migration, inflammatory cells adhere to the site of vascular injury. Within 3 – 7 days post injury, luminal adherent cells decline due to migration of inflammatory to the deeper layers of the vessel wall. In animal models employing either balloon injury or stent
35 implantation, inflammatory cells may persist at the site of vascular injury for

5 at least 30 days (Tanaka et al., 1993; Edelman et al., 1998). Inflammatory cells therefore are present and may contribute to both the acute and chronic phases of restenosis.

10 Numerous agents have been examined for presumed antiproliferative actions in restenosis and have shown some activity in experimental animal models. Some of the agents which have been shown to successfully reduce the extent of intimal hyperplasia in animal models include: heparin and heparin fragments (Clowes, A.W. and Karnovsky M., *Nature*, 265: 25-26, 1977; Guyton, J.R. et al., *Circ. Res.*, 46: 625-634, 1980; Clowes, A.W. and Clowes, M.M., *Lab. Invest.* 52: 611-616, 1985; Clowes, A.W. and Clowes, M.M., *Circ. Res.* 58: 839-845, 1986; 15 Majesky et al., *Circ Res.* 61: 296-300, 1987; Snow et al., *Am. J. Pathol.* 137: 313-330, 1990; Okada, T. et al., *Neurosurgery* 25: 92-98, 1989), colchicine (Currier, J.W. et al., *Circulation* 80: II-66, 1989, taxol (Sollott, S.J. et al., *J. Clin. Invest.* 95: 1869-1876, 1995), angiotensin converting enzyme (ACE) inhibitors (Powell, J.S. et al., *Science*, 245: 186-188, 1989), angiopeptin (Lundergan, C.F. et al., *Am. J. Cardiol.* 17(Suppl. B): 132B-136B, 1991), cyclosporin A (Jonasson, L. et al., *Proc. Natl., Acad. Sci.*, 85: 2303, 1988), goat-anti-rabbit PDGF antibody (Ferns, G.A.A., et al., *Science* 253: 1129-1132, 1991), terbinafine (Nemecek, G.M. et al., *J. Pharmacol. Exp. Thera.* 248: 1167-1174, 1989), trapidil (Liu, M.W. et al., *Circulation* 81: 1089-1093, 1990), tranilast (Fukuyama, J. et al., *Eur. J. Pharmacol.* 318: 327-332, 1996), interferon-gamma (Hansson, G.K. and Holm, J., *Circulation* 84: 1266-1272, 1991), rapamycin (Marx, S.O. et al., *Circ. Res.* 76: 412-417, 1995), steroids (Colburn, M.D. et al., *J. Vasc. Surg.* 15: 510-518, 1992), see also Berk, B.C. et al., *J. Am. Coll. Cardiol.* 17: 111B-117B 1991, 20 ionizing radiation (Weinberger, J. et al., *Int. J. Rad. Onc. Biol. Phys.* 36: 767-775, 1996), fusion toxins (Farb, A. et al., *Circ. Res.* 80: 542-550, 1997) antisense oligonucleotides (Simons, M. et al., *Nature* 359: 67-70, 1992) and gene vectors (Chang, M.W. et al., *J. Clin. Invest.* 96: 2260-2268, 1995). Antiproliferative action on SMC *in vitro* has been demonstrated for many of these agents, 25 including heparin and heparin conjugates, taxol, tranilast, colchicine, ACE 30 35

5 inhibitors, fusion toxins, antisense oligonucleotides, rapamycin and ionizing radiation. Thus, agents with diverse mechanisms of SMC inhibition may have therapeutic utility in reducing intimal hyperplasia.

10 However, unlike animal models, attempts in human angioplasty patients to prevent restenosis by systemic pharmacologic means have thus far been unsuccessful. Neither aspirin-dipyridamole, ticlopidine, anticoagulant therapy (acute heparin, chronic warfarin, hirudin or hirulog), thromboxane receptor antagonism nor steroids have been effective in preventing restenosis, although platelet inhibitors have been effective in preventing acute reocclusion after
15 angioplasty (Mak and Topol, 1997; Lang *et al.*, 1991; Popma *et al.*, 1991). Additionally, the 7E3 humanized monoclonal antibody fragment to the platelet GP IIb/IIIa receptor is still under study but has not shown promising results for the reduction in restenosis following angioplasty and stenting. Other agents, which have also been unsuccessful in the prevention of restenosis, include the
20 calcium channel antagonists, prostacyclin mimetics, angiotensin converting enzyme inhibitors, serotonin receptor antagonists, and antiproliferative agents. These agents must be given systemically, however, and attainment of a therapeutically effective dose may not be possible; antiproliferative (or anti-restenosis) concentrations may exceed the known toxic concentrations of
25 these agents so that levels sufficient to produce smooth muscle inhibition may not be reached (Mak and Topol, 1997; Lang *et al.*, 1991; Popma *et al.*, 1991).

30 Additional clinical trials in which the effectiveness for preventing restenosis of dietary fish oil supplements or cholesterol lowering agents has been examined have shown either conflicting or negative results so that no pharmacological agents are as yet clinically available to prevent post-angioplasty restenosis (Mak and Topol, 1997; Franklin and Faxon, 1993; Serruys, P.W. *et al.*, 1993). Recent observations suggest that the antilipid/antioxidant agent, probucol may be useful in preventing restenosis but
35 this work requires confirmation (Tardif *et al.*, 1997; Yokoi, *et al.*, 1997).

5 Probucol is presently not approved for use in the United States and a 30-day pretreatment period would preclude its use in emergency angioplasty. Additionally, application of ionizing radiation has shown significant promise in reducing or preventing restenosis after angioplasty in patients with stents (Teirstein et al., 1997). Currently, however, the most effective treatments for
10 restenosis are repeat angioplasty, atherectomy or coronary artery bypass grafting, because no therapeutic agents currently have US Federal Regulatory Agency (FDA) approval for use for the prevention of post-angioplasty restenosis.

15 Unlike systemic pharmacologic therapy, stents have proven useful in partially preventing restenosis. Stents, are balloon-expandable slotted metal tubes (usually, but not limited to, stainless steel), which, when expanded within the lumen of an angioplastied coronary artery, provide structural support to the arterial wall. This support is helpful in maintaining vessel lumen patency. In
20 two randomized clinical trials, stents increased angiographic success after PTCA, by increasing minimal lumen diameter and reducing, (but not eliminating,) the incidence of restenosis at 6 months (Serruys et al., 1994; Fischman et al., 1994).

25 Additionally, in a preliminary trial, heparin coated stents appear to possess the same benefit of reduction in stenosis diameter at follow-up as was observed with non-heparin coated stents. Heparin coating also appears to have the added benefit of producing a reduction in sub-acute thrombosis after stent implantation (Serruys et al., 1996). Thus, 1) sustained mechanical expansion of a stenosed coronary artery with a stent has been shown to
30 provide some measure of restenosis prevention, and 2) coating of stents with heparin has demonstrated both the feasibility and the clinical usefulness of delivering drugs locally, at the site of injured tissue.

35 Post-angioplasty restenosis is a multifactorial process that involves numerous interactive mechanisms. This means that effective prevention of

5 restenosis may not be feasible with agents possessing a single mechanism of
action; positive therapeutic results may be best achieved through application of
several agents with differing therapeutic targets. Thus, potential therapeutic
benefit could be found with the co-delivery of agents with different mechanisms
of action targeting different components of the restenosis process.

10

SUMMARY OF THE INVENTION

The current invention comprises an approach to solving the clinical problem
of restenosis, which involves the administration of drug combinations, either
15 locally or systemically. One example of such a combination would be the
addition of the antiinflammatory corticosteroid, dexamethasone, with an
antiproliferative agent such as cladribine, rapamycin, vincristine, taxol, or a
nitric oxide donor. Such combination therapies might result in a better
therapeutic effect (less proliferation as well as less inflammation, a stimulus for
20 proliferation) than would occur with either agent alone. Such agents could be
administered systemically in their respective therapeutic doses, or,
alternatively, could be bound to the surface of a stent by means of
incorporation within either a biodegradable or biostable polymeric coating.
Alternatively, these agents could be incorporated into a stent constructed with
25 a grooved reservoir. Thus, delivery of a stent containing both an
antiproliferative agent and an antiinflammatory agent to a coronary artery
injured during the process of angioplasty would provide the added therapeutic
benefit of 1) limiting the degree of local smooth muscle cell proliferation, 2)
reducing a stimulus for proliferation, i.e., inflammation, and thus enhance the
30 restenosis-limiting action of the stent.

35

In other embodiments of the inventions, growth factor or cytokine signal
transduction inhibitor, such as the ras inhibitor, R115777, or a tyrosine kinase
inhibitor, such as tyrphostin, might be combined with an antiproliferative agent
35 such as taxol, vincristine or rapamycin so that proliferation of SMC could be

5 inhibited by different mechanisms. Alternatively, an antiproliferative agent such as taxol, vincristine or rapamycin could be combined with an inhibitor of extracellular matrix synthesis such as halofuginone. In the above cases, agents acting by different mechanisms could act synergistically to reduce SMC proliferation and vascular hyperplasia. This invention is also intended to cover
10 other combinations of two or more such drug agents. As mentioned above, such agents could be administered systemically, delivered locally *via* drug delivery catheter, or formulated for delivery from the surface of a stent, or given as a combination of systemic and local therapy.

15 **DETAILED DESCRIPTION OF THE DRAWINGS:**

The invention will be better understood in connection with the following figures in which:

20 Figures 1 and 1a are top views and section views of a stent containing reservoirs as described in the present invention;

Figures 2a and 2b are similar views of an alternate embodiment of the stent with open ends;

25 Figures 3a and 3b are further alternate figures of a device containing a grooved reservoir;

Figure 4 is a layout view of a device containing a reservoir as in Figure 3;
30 and

Figures 5, 6, 7, 8 and 9 are a graph of the performance characteristics of stents coated according to this invention.

5

DETAILED DESCRIPTION OF THE INVENTION

Multiple Drug Therapy combined with a Stent

10

As stated previously, implantation of a coronary stent in conjunction with balloon angioplasty is highly effective in treating acute vessel closure and may reduce the risk of restenosis. Intravascular ultrasound studies (Mintz et al., 1996) suggest that coronary stenting effectively prevents vessel constriction and that most of the late luminal loss after stent implantation is due to plaque growth, probably related to neointimal hyperplasia. The late luminal loss after coronary stenting is almost two times higher than that observed after conventional balloon angioplasty. Thus, inasmuch as stents prevent at least a portion of the restenosis process, a combination of agents, which prevent inflammation and proliferation, or prevents proliferation by multiple mechanisms, combined with a stent may provide the most efficacious treatment for post-angioplasty restenosis. In this regard, a stent in conjunction with systemic treatment with the drug combinations suggested above or local delivery of such drug combinations is an attractive treatment. Either systemic or local delivery of multiple drugs from a stent has the following advantages:

15

20

25

1. Prevention of vessel recoil and remodeling through the scaffolding action of the stent;
2. Prevention of multiple components of neointimal hyperplasia, the vascular response to injury

30

Local administration of drug combinations to stented coronary arteries might have additional therapeutic benefit:

35

- 1) higher tissue concentrations would be achievable than would occur with systemic administration;
- 2) reduced systemic toxicity; and

5

3) single treatment/ease of administration

10

An additional benefit of combination drug therapy may be to reduce the dose of each of the therapeutic components and thus limiting their toxicity, while still achieving a reduction in restenosis. Combination therapy is therefore a means of improving the therapeutic ratio (efficacy/toxicity) of an antirestenosis agent.

15

20

As seen in the accompanying Figures 1-4, it is possible to modify currently manufactured stents in order to provide adequate drug delivery. As seen in Figures 1a, 2a and 3a, any stent strut 10, 20, 30 can be modified to have a certain reservoir 11, 21, 31. Each of these reservoirs can be open or closed as desired. These reservoirs can hold the drug to be delivered. Figure 4 shows a stent 40 with a reservoir 45 created at the apex of a flexible connector. Of course, this reservoir 45 is intended to be useful to deliver any drug at a specific point of flexibility of the stent. Accordingly, this concept can be useful for "second generation" type stents. Processes for coating such stents are described, for instance, in Serial Nos. 09/061,568, filed 16 Apr 1998, and 09/512,432 filed 25 Feb 2000, both of which are assigned to a common assignee and are incorporated herein by reference.

25

30

In any of the foregoing devices, however, it is useful to have the drug dosage applied with enough specificity and a sufficient concentration to provide an effective dosage in the lesion area. In this regard, the reservoir size in the stent struts must be kept at a size of about 0.1 mm to about 1 mm depth, and 7 mm to 15 mm length, or enough to hold at least a therapeutic amount of the drug. Then, it should be possible to adequately apply the drug dosage at the desired location and in the desired amount.

5 **Example 1**

To assess the ability of a drug combination to prevent cell proliferation, human smooth muscle cells (Clonetics, Walkersville, MD) were seeded at a density of 10,000 cells/well) into each well of 24-well plates and cultured in growth medium containing heparin, EGF (epidermal growth factor), FGF fibroblast growth factor) and serum. After 24 hours, the growth medium was changed and fresh medium containing various concentrations of test agents (0.01 - 10 mcg/mL) were added to triplicate wells. Medium was replaced with fresh medium (plus test agents) after 3 days. On day five, cells were detached by trypsin/EDTA and counted using a hemacytometer. Cell viability was assessed by trypan blue exclusion.

15 Table 1 provides the percent of control growth of the various tested concentrations of the antiinflammatory agent, dexamethasone, on human smooth muscle cells, either in the absence or presence of 2 concentrations of the antiproliferative/antiimmune agent, rapamycin. Dexamethasone produced a concentration-related decrease in the proliferation of smooth muscle cells in this model system. The IC₅₀ value (concentration required to produce a reduction in proliferation to 50% of the control cell count) for the inhibition of smooth muscle cells with dexamethasone alone estimated from Table 1 is 5 µg/mL. Addition of 0.2 µg/mL of rapamycin to the incubation media was found to reduce the IC₅₀ estimate of dexamethasone to 0.05 µg/mL. A greater added concentration of rapamycin (2 µg/mL) further reduced the IC₅₀ estimate for dexamethasone to less than 0.01 µg/mL.

Thus, as the rapamycin concentration was increased in the incubation media, less dexamethasone was required to produce a 50% inhibition of cell growth. Since the amounts of rapamycin employed did not achieve a 50% inhibition of cell growth, Table 1 demonstrates that concentrations of both rapamycin or dexamethasone below their respective IC₅₀ amounts may combine to produce an effect on cell growth greater than either agent individually. Such a drug combination may be therapeutically useful for inhibition of the intimal

5 smooth muscle cell proliferation that accompanies stent implantation. While efficacy could be maintained at these lower doses, toxicities associated with each of these agents might be ameliorated.

TABLE 1. Inhibition of human vascular smooth muscle cell proliferation with dexamethasone or dexamethasone + rapamycin.

10

	Concentration of Dexamethasone ($\mu\text{g/ml}$)									
	0	0.01	0.05	0.1	0.5	1	5	10	50	100
% of Control Growth										
Rapamycin 0 ug/ml	100.0	-	-	75.2	76.5	72.2	50.0	36.1	18.3	11.7
Standard Deviation	4.2			0.8	16.3	9.3	7.6	5.9	6.0	1.3
Rapamycin 0.2 ug/ml	85.7	63.4	57.6	49.7	48.9	48.2	41.2	31.1	31.2	29.0
Standard Deviation	6.6	3.2	2.1	4.6	2.2	1.7	3.0	2.7	1.0	1.8
Rapamycin 1 ug/ml	67.4	48.3	45.1	38.1	39.2	37.8	33.9	25.8	20.7	18.5
Standard Deviation	2.6	3.3	13.3	9.5	4.4	4.5	3.1	8.1	6.4	3.7

The following examples are used to demonstrate the various configurations of medicated stent coatings containing one or more drugs. These are summarized in Table 2.

15

Table 2: Coating configurations used to demonstrate controlled release of rapamycin and dexamethasone from a stent

Sample I.D.*	Drug Content		Coating Configuration
	Rap ^a	Dex ^b	
50/50	82 μg	82 μg	Drugs are co-mixed with polymer. Total coating wt.: 548 μg
0/100	0 μg	100 μg	Drugs are co-mixed with polymer. Total coating wt.: 641 μg
100/0	150 μg	0 μg	Drugs are co-mixed with polymer. Total coating wt.: 500 μg
67/33	103	51	Drugs are co-mixed with polymer. Total coating wt.: 513 μg
33/67	53	107	Drugs are co-mixed with polymer. Total coating wt.: 534 μg

33/67-3X ^c	182 μ g	363 μ g	Drugs are mixed with polymer. Total coating wt.: 1817 μ g
50/50-OLD ^d	77 μ g	80 μ g	Base coat: Rapamycin mixed with polymer. Overcoat: Dexamethasone mixed with polymer. Total coating wt.: 520 μ g
50/50-OLR ^e	79 μ g	81 μ g	Base coat: Dexamethasone mixed with polymer. Overcoat: Rapamycin mixed with polymer. Total coating wt.: 536 μ g
50/50-TC ^f	100 μ g	100 μ g	Base coat: Drugs are mixed with polymer blend Barrier coat: 158 μ g polybutyl methacrylate. Total coating wt.: 811 μ g
0/100-TC ^f	0 μ g	196 μ g	Base coat: Drugs are mixed with polymer blend Barrier coat: 168 μ g polybutyl methacrylate. Total coating wt.: 839 μ g

5 a: Rapamycin; b: Dexamethasone; c: 3 time coating thickness; d:
Dexamethasone overlayer; e: Rapamycin overlayer; f: Top coated

* First number is % Rapamycin

Second number is % Dexamethasone (by weight)

Example 2

10

This example describes the preparation of a base coating that contains rapamycin

15

Stents were coated with Parylene CTM using a vapor deposition method provided by the manufacturer of the parylene-coating instrument (SCS Madison, Wisconsin). The stent is weighed and then mounted for coating. While the stent is rotating a solution of 1.75mg/ml Poly (ethylene-covinyl acetate)(PEVA), 1.75mg/ml polybutyl methacrylate, and 1.5mg/ml rapamycin dissolved in tetrahydrofuran is sprayed onto it. The coated stent is removed from the spray and allowed to air-dry. After a final weighing the amount of coating on the stent is determined.

20

Example 3

25

This example describes the preparation of a base coating that contains dexamethasone

5 Stents were coated with Parylene C™ using a vapor deposition method provided by the manufacturer of the parylene-coating instrument (SCS Madison, Wisconsin). The stent is weighed and then mounted for coating. While the stent is rotating a solution of 1.75mg/ml Poly (ethylene-co-vinyl acetate)(PEVA), 1.75 mg/ml polybutyl methacrylate, and 1.5 mg/ml
10 dexamethasone dissolved in tetrahydrofuran is sprayed onto it. The coated stent is removed from the spray and allowed to air-dry. After a final weighing the amount of coating on the stent is determined.

Example 4

15 This example describes the preparation of a base coating that contains rapamycin and dexamethasone

Stents were coated with Parylene C™ using a vapor deposition method provided by the manufacturer of the parylene-coating instrument (SCS
20 Madison, Wisconsin). The stent is weighed and then mounted for coating. While the stent is rotating a solution of 1.75 mg/ml Poly (ethylene-co-vinyl acetate)(PEVA), 1.75 mg/ml polybutyl methacrylate, 0.75 mg/ml rapamycin and 0.75 mg/ml dexamethasone dissolved in tetrahydrofuran is sprayed onto it. The
25 coated stent is removed from the spray and allowed to air-dry. After a final weighing the amount of coating on the stent is determined.

Example 5

30 This example describes a stent coating that consists of a base coat containing rapamycin and dexamethasone and a drug-free barrier overcoat

A stent is coated as in Example 4. After the coating is thoroughly dried a solution of 2.5 mg/ml polybutyl methacrylate dissolved in tetrahydrofuran is
35 sprayed onto it. It is then air-dried for a final overcoat weight of 150 µg.

5 **Example 6**

This example describes a stent coating, which consists of a base containing rapamycin and an overlayer with dexamethasone

10 A stent is coated as in Example 2. A solution of 1.75 mg/ml Poly (ethylene-co-vinyl acetate)(PEVA), 1.75 mg/ml polybutyl methacrylate, and 1.5 mg/ml dexamethasone dissolved in tetrahydrofuran is sprayed onto it. The coated stent is removed from the spray and allowed to air-dry. The final weight of each layer is typically 250 µg for a total coating weight of 500µg.

15

Example 7

This example describes a stent coating, which consists of a base containing dexamethasone and an overlayer with rapamycin

20

A stent is coated as in Example 3. A solution of 1.75 mg/ml Poly (ethylene-co-vinyl acetate)(PEVA), 1.75 mg/ml polybutyl methacrylate, and 1.5 mg/ml rapamycin dissolved in tetrahydrofuran is sprayed onto it. The coated stent is removed from the spray and allowed to air-dry. The final weight of each layer is typically 250 µg for a total coating weight of 500µg.

25

The following examples describe the method and results for testing the *in vitro* release of rapamycin and dexamethasone from coated stent.

30 **Example 8**

This example describes the method for performing the *in vitro* release of rapamycin and dexamethasone from coated stent.

35 Each stent was placed in a 2.5mL of release medium (aqueous ethanol, 25 percent by volume at room temperature) contained in a 13 X 100 mm culture tube with a screw cap. The tube was shaken in a water bath (INNOVA™ 3100,

5 New Brunswick Scientific) at 200 rpm while maintaining ambient conditions. After a given time interval (ranging from 15 minutes to one day) the tubes were removed from the shaker and the respective stents carefully transferred to a fresh 2.5 ml Aliquot of release medium. The new tube was placed on the shaker and agitation resumed. A sample was removed from the aliquot, which
10 had previously contained the stent and placed in a HPLC vial for determination of the rapamycin content and dexamethasone, by HPLC.

Example 9

15 This example describes the method for analyzing the release medium for rapamycin.

The HPLC system used to analyze the samples was a Waters Alliance with a PDA 996. This system is equipped with a photodiode array detector. 20µL of
20 each sample was withdrawn and analyzed on a C₁₈ -reverse phase column (Waters Symmetry™ Column: 4.6mm X 100mm RP₁₈, 3.5 µm with a matching guard column) using a mobile phase consisting of acetonitrile/methanol/water (38:34:28 v/v) delivered at a flow rate of 1.2 mL/min. The column was maintained at 60°C through the analysis. Under these analytical conditions
25 rapamycin had a retention time of 4.75 ± 0.1 minutes. The concentration was determined from a standard curve of concentration versus response (area-under the curve) generated from rapamycin standards in the range of from 50ng/mL to 50µg/mL.

30 The results from testing the coated stents for their rapamycin release described above are shown in Figures 5, 7 and 9.

5 **Example 10**

This example describes the method for analyzing the release medium for dexamethasone.

10 The HPLC system used to analyze the samples was a Shimadzu Class-VP Chromatography Laboratory System. This system is equipped with a photodiode array detector. 20 μ L of each sample was withdrawn and analyzed on a C₁₈ -reverse phase column (Waters Symmetry™ Column: 4.6mm X 100mm RP₁₈ 3.5 μ). An isocratic mobile phase consisting of methanol/water (55:45 v/v) delivered at a flow rate of 0.8 mL/min. was used for the first 6.5
15 mins of analysis followed by 100% methanol for 2 minutes; the latter was to ensure removal of rapamycin which is retained on the column. The column was maintained at 25°C throughout the analysis. Under these analytical conditions dexamthasone had a retention time of 5.9 \pm 0.1 minutes. The concentration
20 was determined from a standard curve of concentration versus response (area-under the curve) generated from dexamethasone standards in the range of from 40ng/mL to 4.0 μ g/mL.

25 The results from testing the coated stents for the dexamethasone release described above are shown in Figures 6, 8 and 9.

30 These and other concepts will are disclosed herein. It would be apparent to the reader that modifications are possible to the stent or the drug dosage applied. In any event, however, the any obvious modifications should be perceived to fall within the scope of the invention, which is to be realized from the attached claims and their equivalents.

5 **Example 10**

This example describes the method for analyzing the release medium for dexamethasone.

10 The HPLC system used to analyze the samples was a Shimadzu Class-VP Chromatography Laboratory System. This system is equipped with a photodiode array detector. 20 μ L of each sample was withdrawn and analyzed on a C₁₈ -reverse phase column (Waters Symmetry™ Column: 4.6mm X 100mm RP₁₈ 3.5 μ). An isocratic mobile phase consisting of methanol/water
15 (55:45 v/v) delivered at a flow rate of 0.8 mL/min. was used for the first 6.5 mins of analysis followed by 100% methanol for 2 minutes; the latter was to ensure removal of rapamycin which is retained on the column. The column was maintained at 25°C throughout the analysis. Under these analytical conditions dexamthasone had a retention time of 5.9 \pm 0.1 minutes. The concentration
20 was determined from a standard curve of concentration versus response (area-under the curve) generated from dexamethasone standards in the range of from 40ng/mL to 4.0 μ g/mL.

25 The results from testing the coated stents for the dexamethasone release described above are shown in Figures 6, 8 and 9.

30 These and other concepts will are disclosed herein. It would be apparent to the reader that modifications are possible to the stent or the drug dosage applied. In any event, however, the any obvious modifications should be perceived to fall within the scope of the invention, which is to be realized from the attached claims and their equivalents.

WHAT IS CLAIMED IS:

1. A process for the treatment for restenosis comprising the intravascular infusion or delivery by release from the surface of a stent of combinations of at least two drugs to a patient in therapeutic dosage amounts.
2. The method of claim 1 wherein the combination of agents employed includes an anti-inflammatory agent and an antiproliferative agent.
3. The method of claim 2 wherein the anti-inflammatory agent is dexamethasone and the anti-proliferative agent is taken from the group of rapamycin, taxol, or vincristine.
4. The method of claim 1 wherein the combination of agents employed includes a growth factor or cytokine signal transduction inhibitor and an anti-proliferative agent.
5. The method of claim 4 wherein the signal transduction inhibitor is the ras inhibitor, R115777, and the anti-proliferative agent is taken from the group consisting of rapamycin, taxol, or vincristine.
6. The method of claim 1 wherein the combination of agents employed include a tyrosine kinase inhibitor and an anti-proliferative agent.
7. The method of claim 6 wherein the tyrosine kinase inhibitor is tyrphostin and the antiproliferative agent is taken from the group consisting of rapamycin, taxol, vincristine.
8. The method of claim 1 wherein the combination of agents employed includes an inhibitor of extracellular matrix synthesis and an antiproliferative agent.

5

9. The method of claim 8 wherein the anti-proliferative agent is taken from the group of rapamycin, taxol, or vincristine.

10

10. The method of claims 4 wherein the signal transduction inhibitor, the tyrosine kinase inhibitor or the extracellular matrix inhibitor is administered in combination with an anti-inflammatory inhibitor.

15

11. The method of claim 10 wherein the anti-inflammatory agent is dexamthasone.

12. In combination:

a catheter for the delivery of drugs to a blood vessel lumen of a patient;
and

20

a therapeutic dosage amount of the combination of rapamycin and dexamethasone coated to or delivered through said catheter.

13. In combination:

a stent for the delivery of drugs to a lumen of a patient; and

25

a therapeutic dosage amount of rapamycin and dexamethasone coated to said stent.

14. A stent comprising:

a plurality of struts, said struts expansible within the lumen of the body,
and at least one of said struts containing a reservoir therein; and

30

a therapeutic amount of rapamycin and dexamethasone coated to said stent.

15. The method of claim 8 wherein said exhibitor is halofuginone.

FIG. 1

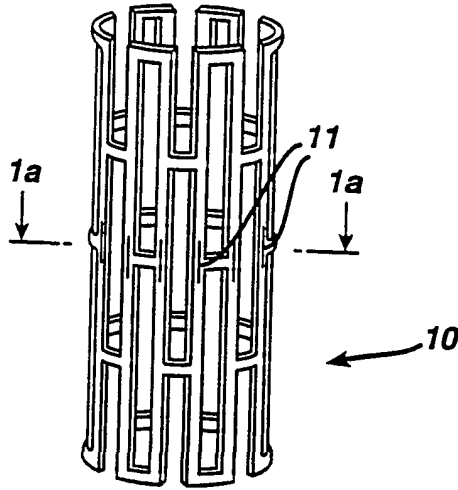

FIG. 1a

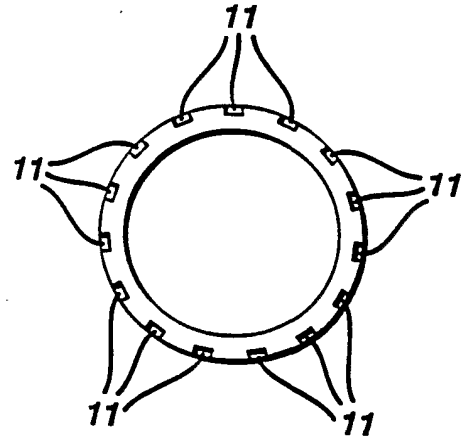

FIG. 2a

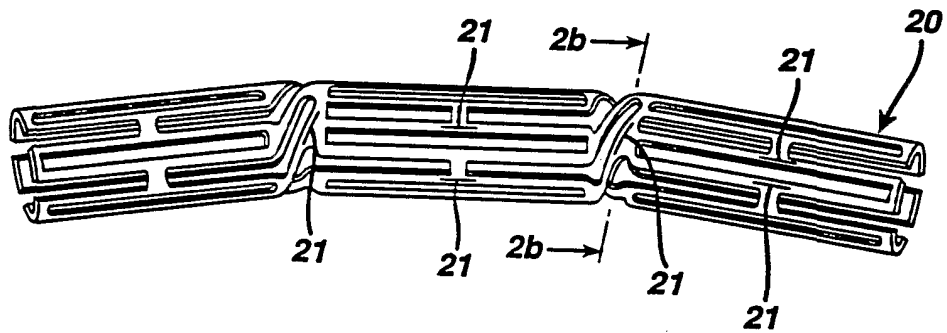

FIG. 2b

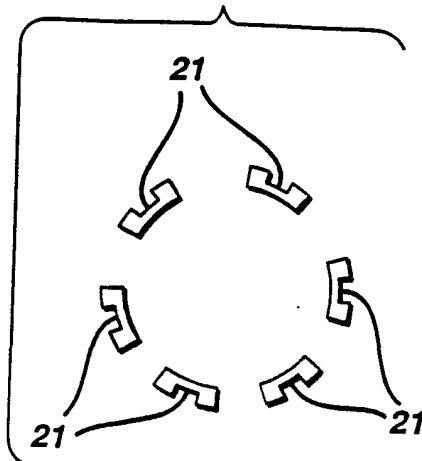

FIG. 3a

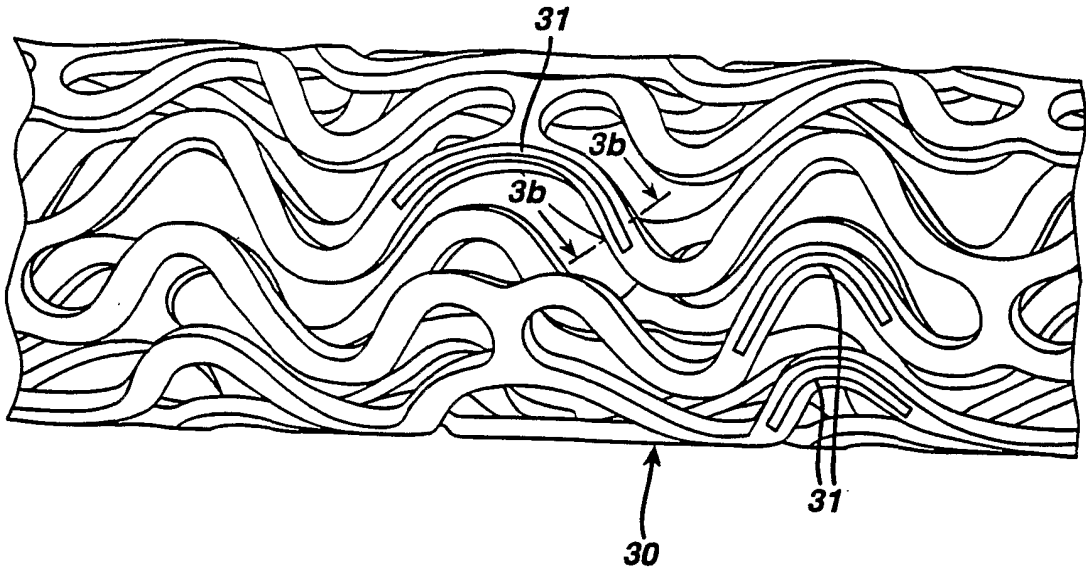

FIG. 3b

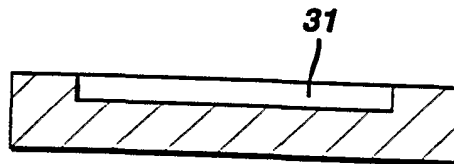
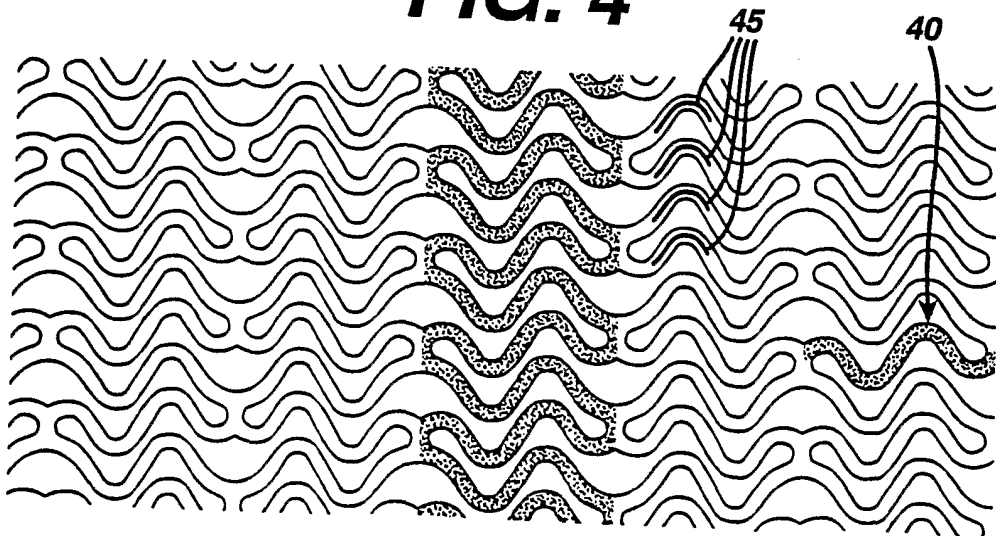
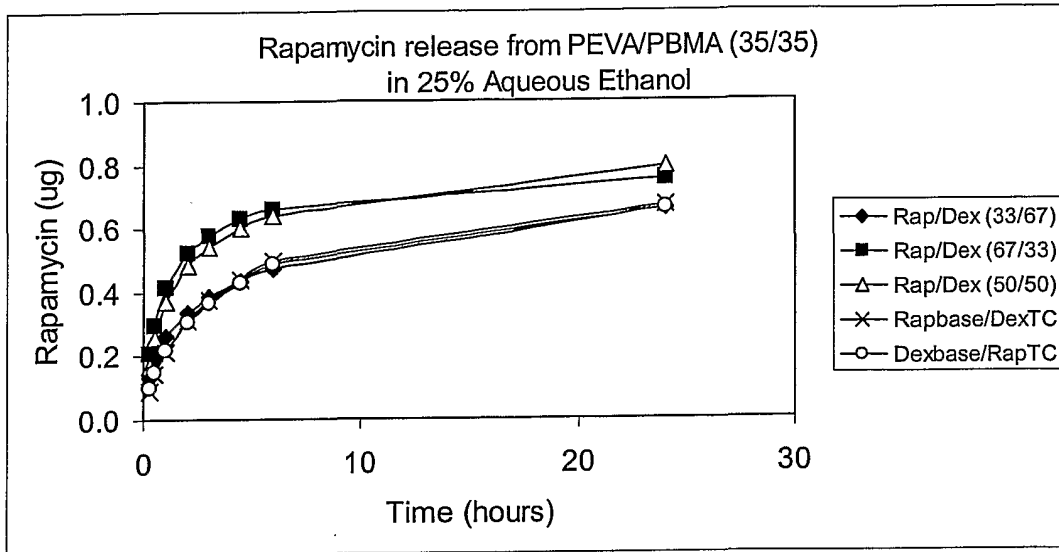

FIG. 4



5

Figure 5



10

15

20

Figure 6

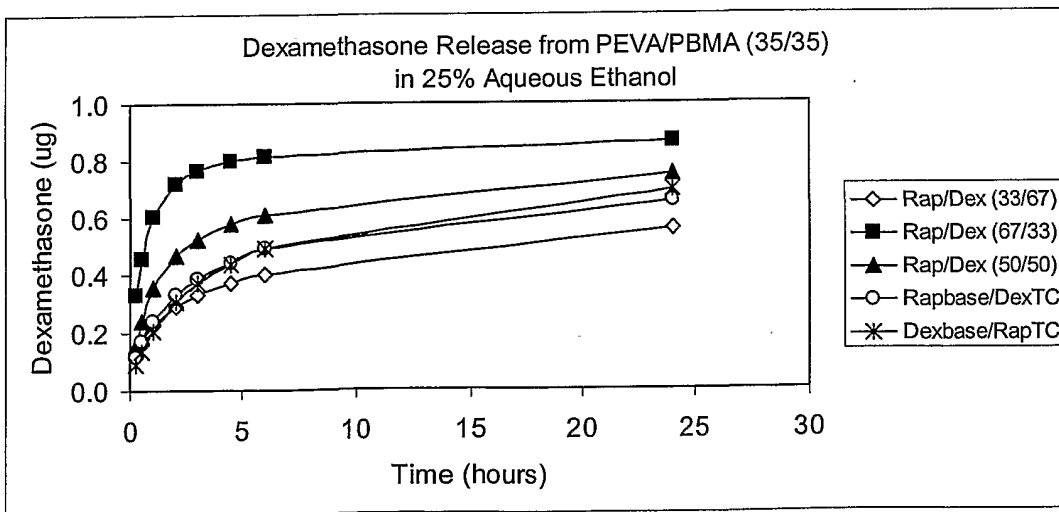

25

30

5

Figure 7

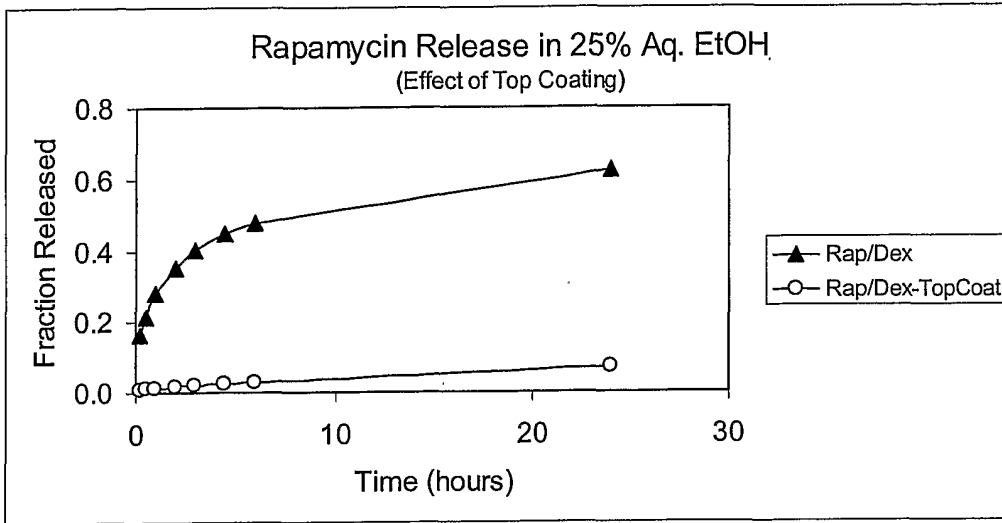

10

15

Figure 8

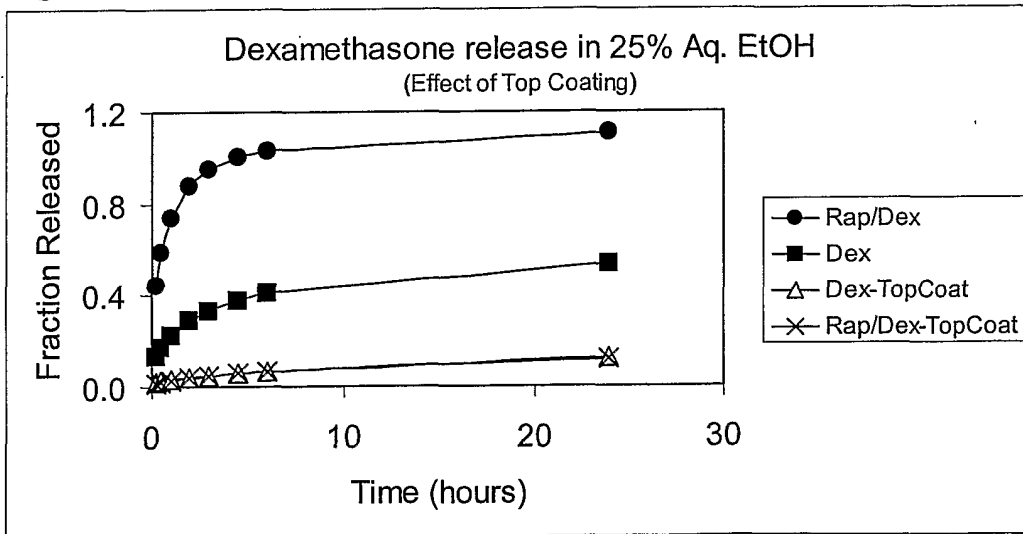

20

25

5

Figure 9

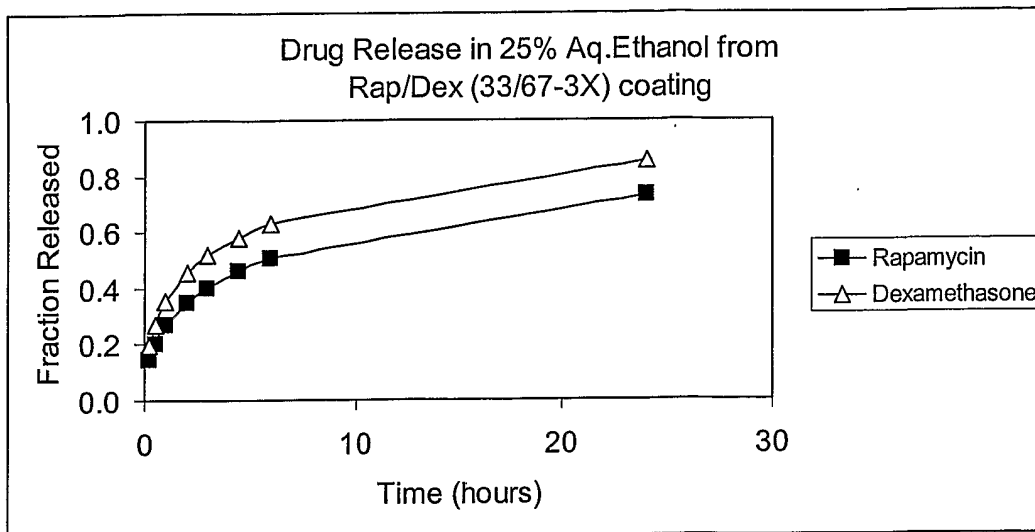

10

15

20

INTERNATIONAL SEARCH REPORT

International Application No
PCT/US 01/13780

A. CLASSIFICATION OF SUBJECT MATTER
IPC 7 A61L31/16

According to International Patent Classification (IPC) or to both national classification and IPC

B. FIELDS SEARCHED

Minimum documentation searched (classification system followed by classification symbols)
IPC 7 A61F A61L A61K

Documentation searched other than minimum documentation to the extent that such documents are included in the fields searched

Electronic data base consulted during the international search (name of data base and, where practical, search terms used)

EPO-Internal, PAJ, WPI Data

C. DOCUMENTS CONSIDERED TO BE RELEVANT

Category °	Citation of document, with indication, where appropriate, of the relevant passages	Relevant to claim No.
X	WO 98 36784 A (COOK INC) 27 August 1998 (1998-08-27) page 6, line 29 -page 7, line 14 page 12, line 14 -page 13, line 27 claims ----	1-14
X	WO 00 21584 A (SCIMED LIFE SYSTEMS INC) 20 April 2000 (2000-04-20) claims ---	1-14
X	EP 0 568 310 A (AMERICAN HOME PROD) 3 November 1993 (1993-11-03) page 5, line 47 - line 49 claims ---	1-9
	-/--	



Further documents are listed in the continuation of box C.



Patent family members are listed in annex.

° Special categories of cited documents :

- *A* document defining the general state of the art which is not considered to be of particular relevance
- *E* earlier document but published on or after the international filing date
- *L* document which may throw doubts on priority claim(s) or which is cited to establish the publication date of another citation or other special reason (as specified)
- *O* document referring to an oral disclosure, use, exhibition or other means
- *P* document published prior to the international filing date but later than the priority date claimed

- *T* later document published after the international filing date or priority date and not in conflict with the application but cited to understand the principle or theory underlying the invention
- *X* document of particular relevance; the claimed invention cannot be considered novel or cannot be considered to involve an inventive step when the document is taken alone
- *Y* document of particular relevance; the claimed invention cannot be considered to involve an inventive step when the document is combined with one or more other such documents, such combination being obvious to a person skilled in the art.
- * & * document member of the same patent family

Date of the actual completion of the international search

2 October 2001

Date of mailing of the international search report

11/10/2001

Name and mailing address of the ISA

European Patent Office, P.B. 5818 Patentlaan 2
NL - 2280 HV Rijswijk
Tel. (+31-70) 340-2040, Tx. 31 651 epo nl,
Fax: (+31-70) 340-3016

Authorized officer

Thornton, S

INTERNATIONAL SEARCH REPORT

 International Application No
 PCT/US 01/13780

C.(Continuation) DOCUMENTS CONSIDERED TO BE RELEVANT

Category *	Citation of document, with indication, where appropriate, of the relevant passages	Relevant to claim No.
A	WO 98 23244 A (HADASIT MED RES SERVICE ;GELLER EHUD (IL); HAZUM ELI (IL); SLAVIN) 4 June 1998 (1998-06-04) claims -----	1,8,15
P,X	WO 00 32255 A (SCIMED LIFE SYSTEMS INC) 8 June 2000 (2000-06-08) page 13, line 13 -page 14, line 12 claims -----	1-14
P,X	WO 00 27445 A (SCIMED LIFE SYSTEMS INC) 18 May 2000 (2000-05-18) page 12, line 1 -page 13, line 2 claims -----	1-14

INTERNATIONAL SEARCH REPORT

Information on patent family members

International Application No

PCT/US 01/13780

Patent document cited in search report		Publication date	Patent family member(s)	Publication date
WO 9836784	A	27-08-1998	AU 737252 B2	16-08-2001
			AU 6663298 A	09-09-1998
			EP 0968013 A1	05-01-2000
			WO 9836784 A1	27-08-1998
WO 0021584	A	20-04-2000	AU 1108800 A	01-05-2000
			EP 1121162 A1	08-08-2001
			WO 0021584 A1	20-04-2000
EP 0568310	A	03-11-1993	US 5288711 A	22-02-1994
			AT 135226 T	15-03-1996
			AU 3713693 A	04-11-1993
			BR 9301667 A	03-11-1993
			CA 2094858 A1	29-10-1993
			DE 69301754 D1	18-04-1996
			DE 69301754 T2	08-08-1996
			DK 568310 T3	29-07-1996
			EP 0568310 A1	03-11-1993
			ES 2085720 T3	01-06-1996
			GR 3019380 T3	30-06-1996
			HK 109097 A	22-08-1997
			HU 64231 A2	28-12-1993
			JP 2550277 B2	06-11-1996
			JP 6080573 A	22-03-1994
SG 43030 A1	17-10-1997			
WO 9823244	A	04-06-1998	IL 119162 A	29-06-2000
			AU 712520 B2	11-11-1999
			AU 6755998 A	22-06-1998
			CN 1219125 A	09-06-1999
			EP 0936910 A2	25-08-1999
			JP 2001500040 T	09-01-2001
			WO 9823244 A2	04-06-1998
WO 0032255	A	08-06-2000	AU 3099900 A	19-06-2000
			EP 1135178 A1	26-09-2001
			WO 0032255 A1	08-06-2000
WO 0027445	A	18-05-2000	US 6187024 B1	13-02-2001
			US 6231590 B1	15-05-2001
			AU 1522500 A	29-05-2000
			EP 1128854 A1	05-09-2001
			WO 0027445 A1	18-05-2000