

(No Model.)

D. C. BAUGHMAN.

RAILROAD SIGNAL.

No. 268,983.

Patented Dec. 12, 1882.

Fig. 1.

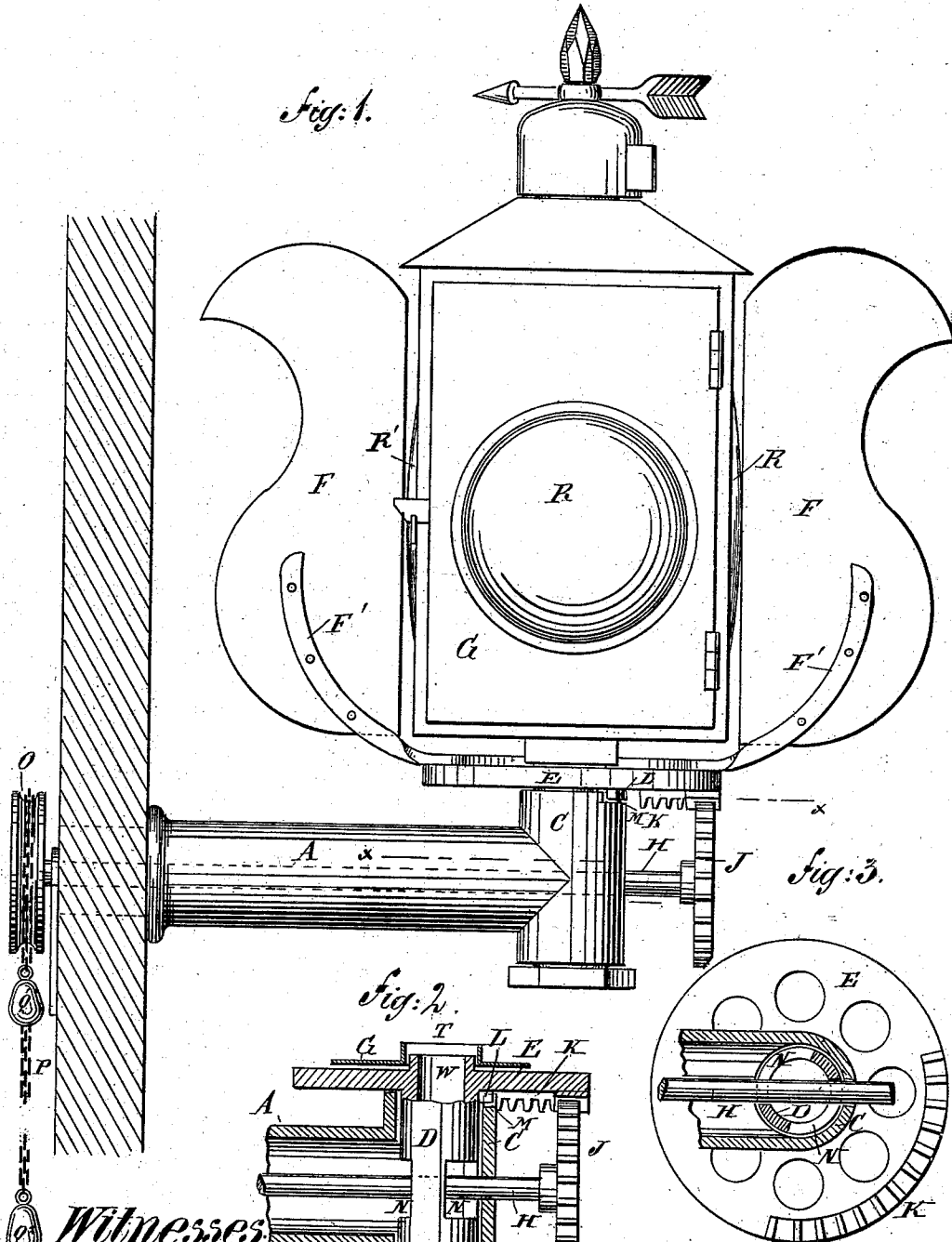
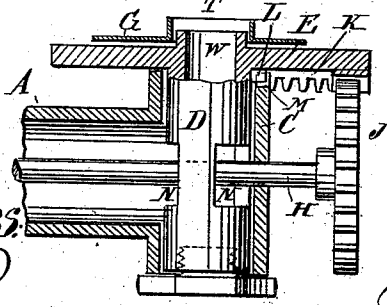

Fig. 3.

Fig. 2.



Witnesses:
C. Mas. Nida.
C. Seigman

Inventor:
D. C. Baughman
 by *Wm. Ho*
 Attorneys.

UNITED STATES PATENT OFFICE.

DAVID C. BAUGHMAN, OF ALBION, INDIANA.

RAILROAD-SIGNAL.

SPECIFICATION forming part of Letters Patent No. 268,983, dated December 12, 1882.

Application filed February 15, 1882. (No model.)

To all whom it may concern:

Be it known that I, DAVID C. BAUGHMAN, of Albion, in the county of Noble and State of Indiana, have invented a new and Improved Railroad-Signal, of which the following is a full, clear, and exact description.

The object of my invention is to facilitate operating railroad-signals.

The invention consists in a novel construction and arrangement of parts, as hereinafter fully described.

Reference is to be had to the accompanying drawings, forming part of this specification, in which similar letters of reference indicate corresponding parts in all the figures.

Figure 1 is a longitudinal elevation of my improved railroad-signal. Fig. 2 is a longitudinal sectional elevation of the end of the tubular arm. Fig. 3 is an inverted sectional plan view of the end of the tubular arm, on the line *x x*, Fig. 1.

A tubular arm or bracket, A, projects from the signal-house or from some other suitable standard, and is provided at its outer end with a vertical journal-box, C, adapted to receive the journal D of a carrier or disk, E, carrying two signal-wings, F, and a removable signal-lantern, G, between these wings. A shaft, H, extends longitudinally through the tubular arm A, and is suitably journaled in the same. The outer end of the shaft H projects from the end of the arm A, and on this end of the shaft is mounted a cog-wheel, J, engaging with a quadrant-rack, K, on the under side of the disk or carrier E. A tooth, L, projecting from the bottom of the carrier E, passes into a quadrant-recess, M, in the upper edge of the journal-box C. The journal D, which is made hollow or tubular, is provided in opposite sides with two horizontal slots, N, through which the shaft H passes, these slots being of such size as to permit a quarter-rotation of the journal D only, as will be described hereinafter.

On the inner end of the shaft H a grooved pulley, O, or a sprocket-wheel, is mounted, over which an overbalancing chain, P, passes, having weights Q¹ Q² attached to the ends. One of these weights, Q², is colored red, and the other, Q¹, is colored white. The signal-wings F are colored red, and those sides of the lamp G that are parallel with the wings are colored

red and are provided with colored lenses R. The other two sides of the lantern, which are at right angles to the wings, are colored white, and are provided with plain lenses R'. The wings F are attached to arms F', attached to the carrier or disk E, and the wings are located such a distance apart that the lantern G can be placed between them. The bottom of the lantern is provided with an aperture, T, which fits directly over the aperture W in the top of the journal D, so that the air can pass through the tubular arm A and the hollow journal D into the lantern. Thereby I prevent the lantern from being extinguished by gusts of wind as the air that passes into the lantern is taken from the inside of the signal-house.

The operation is as follows: If the shaft H is rotated, the cog-wheel J, engaging with the rack K, rotates the signal-carrier E. When the wings F and the lantern G are in the position shown the signal-wings are at right angles to the rails. By a quarter-rotation of the disk E the wings F are brought in a position parallel with the rails. The stud or tooth L strikes against one of the ends of the quadrant-recess M in the upper edge of the journal-box C at the end of each quarter-rotation, and thus the movement of the journal D is checked. When the signal is in one position the corresponding ends of the slots N will rest against the shaft H, and when the journal makes a quarter-revolution the opposite corresponding ends of the slots N will rest against the shaft. The shaft H thus forms an additional check for the rotary movements of the journal D. The shaft H can be rotated by means of electricity, or by mechanical devices, or by means of the chain P, as shown. If this chain overbalances on one side of the pulley O, the weight of the overhanging part of the chain will be sufficient to rotate the pulley O in the direction toward the side from which the chain hangs. This overbalancing part of the chain not only rotates the pulley O and operates the signal, but also locks the same in place, either in one position or the other. With the wheel O the shaft H rotates, and the wheel J rotates the signals. By the position of the weights Q¹ and Q² the person in the signal-house can immediately detect the position of the signals, for the lower weight will always show the same

color as the signal that can be seen from the tracks. For instance, if the wings F are in the position shown in Fig. 1, the red signals can be seen from the tracks, and the weight 5 Q², which is colored red, will be lowered. If the journal D is rotated a quarter-revolution, the white signals will show and the weight Q', which is colored white, will be lowered.

Having thus fully described my invention, 10 what I claim as new, and desire to secure by Letters Patent, is—

1. In a railroad-signal, the combination of a rotary carrier, a tubular arm or bracket, in the end of which said carrier is journaled, and 15 a shaft for rotating the carrier, passing through said arm, substantially as and for the purpose set forth.

2. In a railroad-signal, the arm A, constructed with a vertical journal-box, C, at the end, substantially as herein shown and described, and 20 for the purpose set forth.

3. In a railroad-signal, the combination, with the tubular arm or bracket A, provided with the journal-box C and the hollow journal D 25 of the carrier E, of the lantern G, provided with the aperture T in bottom, fitting over the upper end of the said hollow journal, substantially as and for the purpose set forth.

4. In a railroad-signal, the combination, with 30 the tubular arm or bracket A and the signal-carrier E, of the journal D, provided with the slots or apertures N, and the shaft H, passing longitudinally through said shaft, substantially as and for the purpose set forth.

5. In a railroad-signal, the combination, with 35 the tubular bracket or arm A, provided with the journal-box C, and operating-shaft H, provided with the cog-wheel J, of the signal-carrier E, provided with the slotted journal D and rack K, substantially as and for the purpose 40 set forth.

6. In a railroad-signal, the combination, with the tubular arm or bracket A, the operating-shaft H, provided with the cog-wheel J and the pulley O, and the overbalancing chains P, of 45 the signal-carrier E, provided with the slotted journal D and the rack K, substantially as and for the purpose set forth.

7. In a railroad-signal, the combination, with the carrier E, provided with the rigid signal- 50 wings F, of the removable signal-lantern G, supported upon the carrier between the said wings, substantially as and for the purpose set forth.

8. In a railroad-signal, the combination, with 55 the tubular arm or bracket A, provided with the journal-box C, having its upper end provided with the recess *m*, of the rotary carrier E, journaled in the said box and provided with the tooth L, substantially as and for the pur- 60 pose set forth.

D. C. BAUGHMAN.

Witnesses:

T. B. FELKNER,
L. W. WELKER.