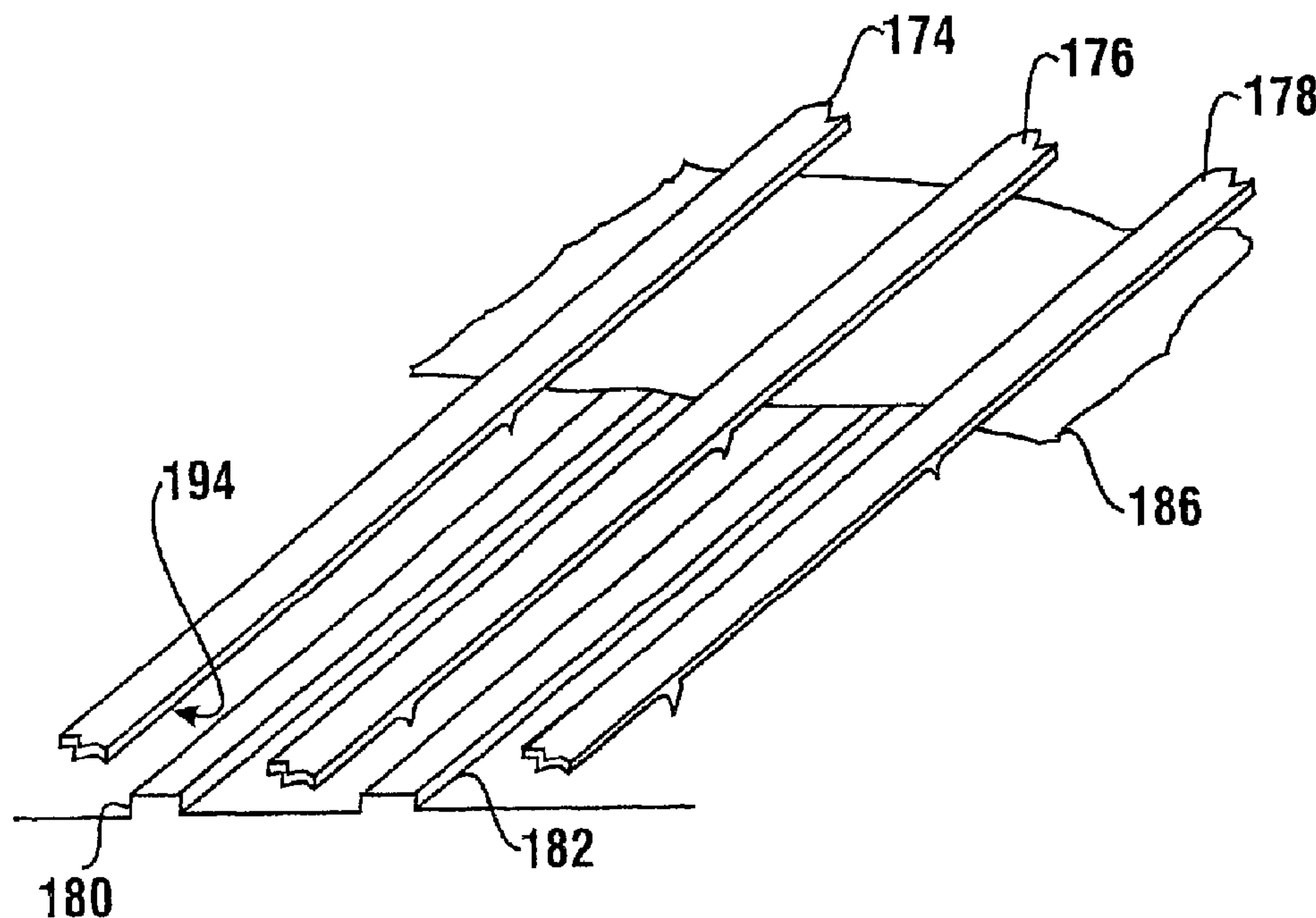




(22) Date de dépôt/Filing Date: 2001/04/10  
 (41) Mise à la disp. pub./Open to Public Insp.: 2001/10/25  
 (45) Date de délivrance/Issue Date: 2006/09/12  
 (62) Demande originale/Original Application: 2 403 107  
 (30) Priorité/Priority: 2000/04/12 (US60/196,874)

(51) Cl.Int./Int.Cl. *G07F 19/00* (2006.01),  
*G07D 11/00* (2006.01)  
 (72) Inventeurs/Inventors:  
GRAEF, H. THOMAS, US;  
PERITT, JONATHAN M., US;  
JOHNSON, MICHAEL S., US;  
VANKIRK, THOMAS A., US  
 (73) Propriétaire/Owner:  
DIEBOLD, INCORPORATED, US  
 (74) Agent: DIMOCK STRATTON LLP

(54) Titre : MACHINE DE TRANSACTIONS AUTOMATISEE  
 (54) Title: AUTOMATED TRANSACTION MACHINE



(57) **Abrégé/Abstract:**

An automated banking machine (10) includes sheet dispensing mechanisms (34, 36, 38, 40). Each sheet dispensing mechanism includes a picking member (72). The picking member rotates, with each rotation generally causing one sheet to be picked from a stack (42) of sheets. The picking member includes movable engaging portions supported on arcuate segments (128, 144). The engaging portions move radially outward to apply additional moving force to an end note bound in the stack responsive to movement of the picking member exceeding the movement of the end note. Sheets are carried in the machine by a transport (54) including a plurality of belt flights (174, 176, 178). Sheets are carried between the belt flights and projecting member portions (180, 182). At least one of the belt flights includes a plurality of longitudinally spaced projections (194, 200, 204, 207) on a sheet engaging surface thereof. The projections provide improved engagement with sheets moving in the transport enabling more reliable movement of sheets.

(12) INTERNATIONAL APPLICATION PUBLISHED UNDER THE PATENT COOPERATION TREATY (PCT)

(19) World Intellectual Property Organization  
International Bureau(43) International Publication Date  
25 October 2001 (25.10.2001)

PCT

(10) International Publication Number  
WO 01/80120 A1(51) International Patent Classification<sup>7</sup>: G06F 17/60

Michael, S.; 1003 Eagle Drive #102, Akron, OH 44612 (US). VANKIRK, Thomas, A.; 6299 Secrest Road, Wooster, OH 44691 (US).

(21) International Application Number: PCT/US01/11627

(22) International Filing Date: 10 April 2001 (10.04.2001)

(74) Agent: JOCKE, Ralph; 231 South Broaway, Medina, OH 44256 (US).

(25) Filing Language: English

(81) Designated States (*national*): BR, CA, CN, CO, IN, MX, PL, RU, ZA.

(26) Publication Language: English

(30) Priority Data:  
60/196,874 12 April 2000 (12.04.2000) US(84) Designated States (*regional*): European patent (AT, BE, CH, CY, DE, DK, ES, FI, FR, GB, GR, IE, IT, LU, MC, NL, PT, SE, TR).(71) Applicant: DIEBOLD, INCORPORATED [US/US];  
5995 Mayfair Road, North Canton, OH 44720 (US).

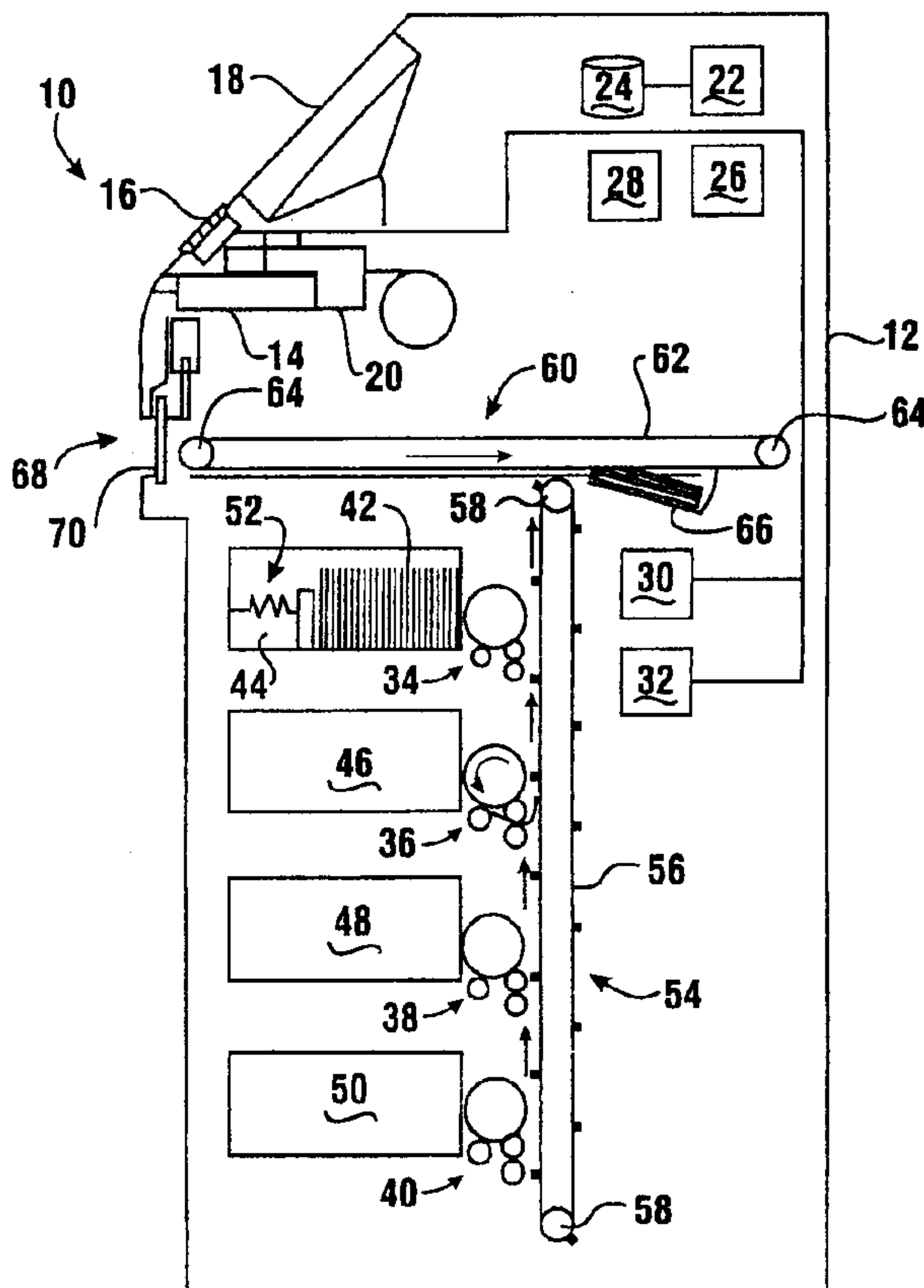
Published:

— with international search report

(72) Inventors: GRAEF, H., Thomas; Box 287, Bolivar, OH 44612 (US). PERITT, Jonathan, M.; 890 Postiy Street NW, North Canton, OH 44612 (US). JOHNSON,

For two-letter codes and other abbreviations, refer to the "Guidance Notes on Codes and Abbreviations" appearing at the beginning of each regular issue of the PCT Gazette.

(54) Title: AUTOMATED TRANSACTION MACHINE



(57) Abstract: An automated banking machine (10) includes sheet dispensing mechanisms (34, 36, 38, 40). Each sheet dispensing mechanism includes a picking member (72). The picking member rotates, with each rotation generally causing one sheet to be picked from a stack (42) of sheets. The picking member includes movable engaging portions supported on arcuate segments (128, 144). The engaging portions move radially outward to apply additional moving force to an end note bound in the stack responsive to movement of the picking member exceeding the movement of the end note. Sheets are carried in the machine by a transport (54) including a plurality of belt flights (174, 176, 178). Sheets are carried between the belt flights and projecting member portions (180, 182). At least one of the belt flights includes a plurality of longitudinally spaced projections (194, 200, 204, 207) on a sheet engaging surface thereof. The projections provide improved engagement with sheets moving in the transport enabling more reliable movement of sheets.

WO 01/80120 A1

**AUTOMATED TRANSACTION MACHINE****TECHNICAL FIELD**

This invention relates to automated transaction machines. Specifically  
this invention relates to an automated transaction machine including a note  
5 delivery mechanism and sheet transport.

**BACKGROUND ART**

Automated transaction machines include automated banking machines.  
A common type of automated banking machine is an automated teller machine  
("ATM"). ATMs may be used to perform transactions such as dispensing  
10 cash, accepting deposits, making account balance inquiries, paying bills and  
transferring funds between accounts. ATMs and other types of automated  
banking machines may be used to dispense documents such as tickets, scrip,  
vouchers, checks, gaming materials, receipts or other documents. While many  
types of automated banking machines, including ATMs, are operated by  
15 consumers, other types of automated banking machines may be operated by  
service providers. Such automated banking machines may be used by service  
providers to provide cash or other types of sheets or documents when  
performing transactions for customers. For purposes of this disclosure, an  
automated banking machine shall be construed as any machine that is capable  
20 of carrying out transactions which include transfers of value.

A popular brand of automated banking machine is manufactured by  
Diebold, Incorporated, the assignee of the present invention. Such automated  
banking machines are capable of selectively dispensing sheets to users of the  
machine. A sheet dispensing mechanism used in such machines includes a  
25 picking mechanism which delivers or "picks" sheets generally one at a time  
from a stack of sheets stored within the machine. The sheets are transported  
through one or more transports within the machine and eventually delivered to  
a user. A picking mechanism used in some Diebold automated banking  
machines is described in U.S. Patent No. 5,577,720.

30

The picking mechanism includes a rotating

picking member that comprises a plurality of cylindrical portions disposed along a shaft. Each cylindrical portion includes a high friction segment along a portion of the circumference. These high friction segments are sized and positioned such that upon each rotation of the picking member, an end note bounding an end of the stack is exposed to the moving high friction segment. Such exposure causes the end note to be moved away from the stack in engagement with the moving cylindrical portions of the picking member.

Disposed adjacent to each of the cylindrical portions of the picking member and in the direction of rotation of the picking member relative to the stack when picking the notes, are a plurality of stripping members. A stripping member is disposed in generally abutting relation with each of the cylindrical portions of the picking member. Each stripping member is generally circular and does not rotate during rotation of the picking member in a note picking direction. The stripping member generally operates to prevent all but the end note from moving out of the stack upon rotation of the picking member. The stripping member operates to prevent generally all but the end note from being delivered from the stack because the force applied by the picking member directly on the end note exceeds the resistance force applied by the stripping member to the end note. However the resistance force of the stripping member acting on notes in the stack other than the end note, because such notes are not directly engaged with the picking member, generally prevents the other notes from moving from the stack.

In the exemplary embodiment of the picking mechanism, the stripping members are each supported through one-way clutch mechanisms. These one-way clutch mechanisms prevent the stripping members from turning responsive to the force applied to the stripping members as the picking member moves to pick a note. However the one-way clutch in connection with each stripping member enables each stripping member to rotate in a direction opposite to that which the stripping member is urged to move during picking. This is useful in situations where a doubles detector senses that more than one note has moved past the stripping member. In such circumstances a

controller operating in the banking machine may operate to cause the picking member to rotate in an opposed direction, which is the opposite of the direction in which the picking member normally moves when picking a note. As the picking member moves in this opposed direction, the stripping member  
5 rotates so as to facilitate the movement of the multiple sheets back toward the stack. Once the multiple sheets have been moved back toward the stack and beyond the stripping member, the controller may operate to cause the picking mechanism to again try to pick a single note from the stack.

In many existing automated banking machines produced by the  
10 assignee of the present invention, notes that are picked from the dispenser are moved through a transport of the type shown in U.S. Patent No. 5,342,165.

Such transports include a plurality of generally parallel and transversely disposed belt flights which move the notes in engagement therewith. Disposed between each  
15 adjacent pair of belt flights is a projecting member. The projecting member generally extends to at least the level of the sheet engaging surfaces of the adjacent belt flight. As a result sheets are captured in sandwiched relation between the projecting members and the belt flight. This sandwiching of the sheets causes the sheets to move with the moving belt flights to selected  
20 locations in the machine. For example as shown in the incorporated disclosure, the sheets are moved in engagement with the belt flight into a stack. Once the stack of sheets has been accumulated, the stack is engaged with belt flights so that it can be moved to be presented to a user of the machine.

25 The sheet dispenser mechanisms and transports described are highly reliable and have been used extensively in automated banking machines. However, problems can sometimes be encountered in the picking and transport of sheets. In some circumstances sheets may have relatively high surface tension and an affinity for adjacent sheets. This may prevent an end  
30 note from being readily separated from a stack of sheets. Alternatively an end note may be worn or soiled in a way that reduces its frictional properties. In

such cases an end note may be more resistant to the forces of the high friction segment on the picking member and will not readily separate from the stack. In alternative situations the picking mechanism may be picking a type of sheet which is plasticized or otherwise has reduced frictional properties relative to the high friction segment on the picking member. In such circumstances picking the end note from a stack may prove more difficult to accomplish reliably.

Difficulties in picking sheets may also be encountered due to wear or malfunctions. After extended use the high friction segments on a picking member can become worn. This results in the segments providing less engaging force to move an end note. Alternatively or in addition, high friction segments may become soiled with use, which may also have the effect of reducing the frictional properties of the picking member. The currency canisters which hold the stack of notes also provide a biasing force to hold the end note in abutting relation with the picking member. As a result of damage or wear, the mechanism which provides the biasing force may not provide as great a force biasing the end note to engage the picking member as may be desirable to achieve highly reliable picking of sheets.

In circumstances where the picking member has difficulty picking a note, the note fails to move in coordinated relation with the high friction segments on the cylindrical portions of the picking member. The high friction segments may rotate past the end note leaving the end note generally in the stack. When this situation occurs the machine controller generally operates so that repeated attempts are made to pick the note. If the note cannot be removed from the stack, the machine may operate in accordance with its programming to provide notes from other supplies through other picking mechanisms within the machine. Alternatively the machine may indicate a malfunction and be placed out of service. In either case the extended transaction time or complete inability to carry out a user's transaction presents a significant inconvenience to the user of the machine.

Notes with less than optimum properties may also cause problems

when being transported within the machine. Notes that have become wet or soiled may adhere to the projecting members and may fail to move with the belt flights in the transport. Notes that are slippery or have unduly low friction may not produce sufficient engaging force with the moving belt flights and may not move in coordinated relation with the belt flights.

Likewise unduly worn or limp notes may not achieve normal engaging force with the belt flights and may become stuck or otherwise fail to move in a transport.

These conditions also present the potential for delaying a transaction or placing a machine out of service. The problem of notes sticking in a transport may also result in the misdispensing of notes. In some circumstances notes may be crumpled or damaged due to transport problems.

Thus there exists a need for improvements to picking mechanisms and sheet transports used in automated banking machines. There further exists a need for improvements to picking mechanisms and transports used in automated banking machines that can be readily installed in existing machines to facilitate use with notes and sheet types having a wider range of properties.

#### DISCLOSURE OF INVENTION

It is an object of an exemplary form of the present invention to provide an automated banking machine.

It is a further object of an exemplary form of the present invention to provide an automated banking machine with an improved system for picking sheets.

It is a further object of an exemplary form of the present invention to provide an automated banking machine with an improved system for transporting sheets.

It is a further object of an exemplary form of the present invention to provide an automated banking machine which provides added force when necessary for picking or transporting sheets.

It is a further object of an exemplary form of the present invention to provide a method for picking sheets in an automated banking machine.

It is a further object of an exemplary form of the present invention to provide a method for transporting sheets in an automated banking machine.

It is a further object of an exemplary form of the present invention to provide a method for improving the operation of an automated banking  
5 machine.

It is a further object of an exemplary form of the present invention to provide a method for upgrading an existing machine to provide for improved picking of sheets.

10 It is a further object of an exemplary form of the present invention to provide a method for upgrading an existing automated banking machine to provide for improved transport of sheets.

Further objects of exemplary forms of the present invention will be made apparent in the following Best Modes For Carrying Out Invention and the appended claims.

15 The foregoing objects are accomplished in an exemplary embodiment of the present invention by replacing the picking member in the prior art sheet dispenser mechanism with, or otherwise providing an alternate picking member that provides for applying additional force to move a sheet from a stack in situations where the sheet does not move with the picking member.  
20 In the exemplary embodiment the sheets which are picked through operation of the picking member are notes that are picked from a stack. The stack is bounded by an end note which engages the picking member.

The alternative picking member includes at least one movable engaging portion. The movable engaging portion is movable relative to the  
25 rotating picking member. The alternate picking member operates so that when the picking member rotates about its axis to pick a note, the engaging portion is in engagement with the end note being picked. In circumstances where the picking member rotates such that the movement of the picking member exceeds the movement of the end note, the engaging portion moves  
30 further radially outward relative to the picking member. This outward movement of the engaging portion applies increasing engaging force to the

end note. This increasing engaging force results in additional force tending to move the end note relative to the stack.

5 The exemplary form of the alternate picking member includes a cam surface and a cam follower portion. The cam follower portion is operatively connected to the engaging portion. The action of the cam surface and cam  
10 follower portion operates to cause the engaging portion to move radially inward when necessary, before the engaging portion passes adjacent to the stripping member. This avoids the engaging portion from colliding with the stripping member and prevents damage to the dispenser mechanism as well as to notes that are moved therethrough.

The exemplary form of the present invention further includes a sheet transport for transporting notes or sheets that have been dispensed from the dispenser mechanism. The sheet transport includes a plurality of belts which include a plurality of generally parallel transversely spaced belt flights.  
15 Projecting member portions extend generally parallel and intermediate of the belt flights. This configuration enables sheets to move in sandwiched relation between the belt flights and the projecting member portions. To provide more reliable movement of sheets, at least one of the conventional belts is replaced with an alternate belt. While the conventional belts have a generally smooth  
20 continuous sheet engaging surface, the exemplary form of the alternate belt includes at least one and preferably a plurality of, projections that extend from the sheet engaging surface of the belt. As a result, sheets which become stuck due to adhesion to the projecting member portions will be engaged by the projections and urged to move in the transport. Similarly sheets which do not  
25 have sufficient frictional engagement with the belt flights to be moved along the transport, are engaged by the projections and urged to move therewith. This minimizes the risk that sheets will become hung up in the transport and results in higher reliability of the machine.

30 The exemplary form of the picking member and belt may be installed in new machines or in existing automated banking machines without further substantial modifications to the machines. This may enable enhancing

machine reliability quickly and at a modest cost.

According to an aspect of the invention, an apparatus is provided which comprises an automated banking machine including a sheet transport therein. The sheet transport includes at least one belt flight extending in a longitudinal direction, wherein the at least one belt flight includes a first sheet engaging surface facing generally in a first facing direction generally normal of the longitudinal direction, wherein the first sheet engaging surface includes at least one projection extending generally in the first facing direction, at least one longitudinally extending projecting member portion extending parallel to the at least one belt flight, wherein the longitudinally extending projecting member portion includes a second sheet engaging surface facing generally in a second facing direction generally normal of the longitudinal direction and opposed of the first facing direction, wherein the sheet transport is operative to move at least one sheet in the longitudinal direction in engagement with the first and second sheet engaging surfaces.

According to a further aspect of the invention, an apparatus is provided which comprises an automated banking machine including a sheet transport therein. The sheet transport includes a plurality of generally parallel belt flights extending in a longitudinal direction, wherein each of the belt flights includes a first sheet engaging surface facing generally in a first facing direction generally normal of the longitudinal direction, wherein the first sheet engaging surface of at least one belt flight includes a plurality of longitudinally spaced projections extending generally in the first facing direction, at least one longitudinally extending projecting member portion extending parallel to and transversely intermediate to immediately transversely adjacent belt flights, wherein the at least one longitudinally extending projecting member portion includes a second sheet engaging surface facing generally in a second facing direction generally normal of the longitudinal direction and opposed of the first facing direction, wherein the sheet transport is operative to move at least one sheet in the longitudinal direction in engagement with the first and second sheet engaging surfaces.

According to yet a further aspect of the invention, an apparatus is provided which comprises an automated banking machine including a sheet transport therein.

8a

The sheet transport includes a plurality of generally parallel belt flights extending in a longitudinal direction, wherein each of the belt flights includes a first sheet engaging surface facing generally in a first facing direction generally normal of the longitudinal direction, wherein each of the first sheet engaging surfaces includes a plurality of

5 longitudinally spaced projections extending generally in the first facing direction from the sheet engaging surface, wherein the projections extend at predetermined spaced intervals on each first sheet engaging surface, wherein each projection extends in a direction generally transverse to the longitudinal direction, wherein each projection comprises resilient material, a plurality of longitudinally extending projecting member

10 portions, wherein each projecting member portion includes a second sheet engaging surface facing generally in a second facing direction generally normal of the longitudinal direction and opposed of the first facing direction, wherein each projecting member portion extends parallel to and transversely intermediate to immediately transversely adjacent belt flights, wherein the sheet transport is operative

15 to move sheets in the longitudinal direction in engagement with the first and second sheet engaging surfaces.

**BRIEF DESCRIPTION OF DRAWINGS**

Figure 1 is a side schematic view of an automated banking machine incorporating an exemplary embodiment of the present invention.

5 Figure 2 is a side view of a picking member used in an exemplary embodiment of the present invention.

Figure 3 is a cross sectional view of the picking member shown in Figure 2 in operative connection with a drive in the machine.

Figure 4 is a side view of the picking member shown in Figure 3.

10 Figure 5 is a side schematic view of the picking member operating to move an end note from the stack in circumstances where the end note moves in coordinated relation with the picking member.

Figure 6 is a view similar to Figure 5 but showing the movement of the engaging portion of the picking member radially outward responsive to the picking member moving in a picking direction without corresponding movement of the end note.

Figures 7-10 are side schematic views showing a sequence of positions of the engaging portion of the picking member and the operation of the cam surface to retract the engaging member as the picking member rotates.

20 Figure 11 is an isometric view of a portion of a belt flight including longitudinally spaced projections thereon.

Figure 12 is a side cross sectional view of the sheet transport showing a sheet in engagement with a plurality of belt flights and projecting member portions.

25 Figure 13 is an isometric view of a sheet transport including belt flights of the type shown in Figure 11 operating to move a sheet through the transport.

Figure 14 is a side schematic view showing a sheet that has been dispensed by a dispenser mechanism moving to engage a sheet transport.

30 Figures 15-17 show alternative exemplary forms of projections positioned on belt flights which may be used in connection with sheet

transports including the improvement of the present invention.

#### BEST MODES FOR CARRYING OUT INVENTION

Referring now to the drawings and particularly Figure 1, there is shown therein an exemplary embodiment of an automated banking machine generally indicated 10. In the exemplary embodiment machine 10 is an ATM. However it should be understood that the invention may be used in connection with other types of automated transaction machines and banking machines.

Automated banking machine 10 includes a housing 12 which houses certain components of the machine. The components of the machine include input and output devices. In this exemplary embodiment the input devices include a card reader schematically indicated 14. Card reader 14 is operative to read a customer's card which includes information about the customer thereon, such as the customer's account number. In embodiments of the invention the card reader 14 may be a card reader adapted for reading magnetic stripe cards and/or so-called "smart cards" which include a programmable memory. Another input device in the exemplary embodiment are input keys 16. Input keys 16 may in embodiments of the invention, be arranged in a keypad or keyboard. Input keys 16 may alternatively or in addition include function keys or other types of devices for receiving manual inputs. It should be understood that in various embodiments of the invention other types of input devices may be used such as biometric readers, speech or voice recognition devices, inductance type readers, IR type readers, and other devices capable of communicating with a person, article or computing device, radio frequency type readers and other types of devices which are capable of receiving information that identifies a customer and/or their account.

The exemplary embodiment of machine 10 also includes output devices providing outputs to the customer. In the exemplary embodiment machine 10 includes a display 18. Display 18 may include an LCD, CRT or other type display that is capable of providing visible indicia to a customer. In other embodiments of the invention output devices may include devices such as audio speakers, RF transmitters, IR transmitters or other types of devices

that are capable of providing outputs which may be perceived by a user either directly or through use of a computing device, article or machine. It should be understood that embodiments of the invention may also include combined input and output devices such as a touch screen display which is capable of providing outputs to a user as well as receiving inputs.

The exemplary embodiment of the automated banking machine 10 also includes a receipt printer schematically indicated 20. The receipt printer is operative to print receipts for users reflecting transactions conducted at the machine. Forms of the invention may also include other types of printing mechanisms such as statement printer mechanisms, ticket printing mechanisms, check printing mechanisms and other devices that operate to apply indicia to media in the course of performing transactions carried out with the machine.

Automated banking machine 10 further includes one or more controllers schematically indicated 22. Controller 22 includes one or more processors that are in operative connection with a memory schematically indicated 24. The controller is operative to carry out programmed instructions to achieve operation of the machine in accomplishing transactions. As schematically indicated, the controller is in operative connection with a plurality of the transaction function devices included in the machine.

The exemplary embodiment of the invention includes at least one communications device 26. The communications device may be one or more of a plurality of types of devices that enable the machine to communicate with other systems and devices for purposes of carrying out transactions. For example communications device 26 may include a modem for communicating messages over a data line or wireless network, with one or more other computers that operate to transfer data representative of the transfer of funds in response to transactions conducted at the machine. Alternatively the communications device 26 may include various types of network interfaces, line drivers or other devices suitable to enable communication between the machine 10 and other computers and systems.

Machine 10 also includes a plurality of sensing devices for sensing various conditions in the machine. These various sensing devices are represented schematically by component 28 for simplicity and to facilitate understanding. It should be understood that a plurality of sensing devices are provided in the machine for sensing and indicating to the controller 22 the status of devices within the machine.

Automated banking machine 10 further includes a plurality of actuators schematically indicated 30 and 32. The actuators may comprise a plurality of devices such as motors, solenoids, cylinders, rotary actuators and other types of devices that are operated responsive to the controller 22. It should be understood that numerous components within the automated banking machine are operated by actuators positioned in operative connection therewith. Actuators 30 and 32 are shown to schematically represent such actuators in the machine and to facilitate understanding.

In the exemplary automated banking machine 10 there are four sheet dispenser mechanisms 34, 36, 38 and 40. Each sheet dispensing mechanism is operative responsive to the controller 22 to pick sheets. Sheets may be selectively picked generally one at a time from a stack of sheets such as stack 42 shown adjacent to sheet dispenser mechanism 34. In the exemplary embodiment each of the stacks of sheets associated with a respective sheet dispenser mechanism is housed in a canister. A canister 44 houses sheets in connection with dispenser mechanism 34. Likewise a canister 46 houses sheets to be picked by dispenser mechanism 36. A canister 48 houses sheets dispensed by dispenser mechanism 38 and a canister 50 houses sheets that are dispensed by dispenser mechanism 40. As schematically represented in canister 44, the stack of sheets 42 is biased to engage the sheet dispenser mechanism by a biasing mechanism 52.

In the exemplary embodiment, canisters 44, 46, 48 and 50 are used to house sheets having predetermined value such as bank notes. Such bank notes may be of various denominations which enable dispensing money in varying amounts to customers. Alternatively one or more of the canisters may hold

other types of sheets such as coupons, scrip, tickets, money orders or other items of value. The controller operates the dispenser mechanism selectively in response to customer inputs and information from systems with which the machine communicates, to cause sheets to be selectively dispensed from the  
5 canisters.

Notes that are dispensed from the canisters in the exemplary embodiment are engaged with a first note transport schematically indicated 54. First note transport 54 which is later described in detail, includes a plurality of continuous belts 56. The belts extend around sets of rollers 58  
10 which operate to drive and guide the belts. As shown schematically in Figure 1 by the sheet dispensed from dispenser mechanism 36, sheets are enabled to engage the adjacent flights of belts 56 and move in engagement therewith upward to a second transport 60.

The second transport 60 in the exemplary embodiment is similar to  
15 that shown in U.S. Patent No. 5,342,165.

Transport 60 also includes a plurality of continuous belts 62 which extend about sets of rollers 64. Rollers 64 operate to drive the belt 62 such that notes passing upward in transport 54 initially engage flights of belt 62 and are collected into a stack 66.  
20 In response to operation of the controller 22 when a desired number of notes have been collected in the stack 66, the stack is moved in the manner of the incorporated disclosure and the belts 62 are driven so that the stack 66 is moved toward a user opening 68 in the housing 12 of the machine. As the notes are moved toward the opening 68, the controller operates a suitable  
25 actuating device to operate a gate 70 so as to enable the stack to pass outward through the opening. As a result the user is enabled to receive the sheets from the machine. After a user is sensed as having removed the stack from the opening, the controller may operate to close the gate 70 so as to minimize the risk of tampering with the machine.

30 It should be understood that the devices shown in connection with exemplary automated banking machine 10 are representative of devices that

may be found in such machines. Numerous additional or alternative types of devices such as deposit accepting devices, document reading devices, currency accepting devices, ticket printing devices and additional devices may be included in automated banking machines which are used in connection with the present invention.

Figure 14 shows the sheet dispenser mechanism 34 in greater detail. In the exemplary embodiment of the machine 10 all the dispenser mechanisms are the same, therefore only one will be described in detail. Dispenser mechanism 34 includes a picking member 72. The picking member 72 is selectively rotated responsive to the controller 22 about an axis 74. Bank notes or other sheets in the stack 42 are supported by a supporting surface 76 which terminates in the area adjacent to the picking member. An end note 78 bounds the stack adjacent to the picking member 72. During each rotation of the picking member the then current end note bounding the stack is moved and delivered from the stack and passed to the transport 54.

The picking member 72 has an outer bounding surface 80. The outer bounding surface 80 is in generally abutting relation with stripping members 82. As previously discussed the stripping members 82 in the exemplary embodiment do not rotate in a clockwise direction as shown in Figure 14. In the exemplary embodiment, the stripping members 82 will however rotate in a counterclockwise direction due to action of associated one-way clutches as later described.

Positioned downstream of the stripping members 82 is a doubles detector 84. Doubles detector 84 may be a mechanical sensor, radiation sensor, sonic sensor or other type sensor that is suitable for determining if single or multiple notes have moved past the stripping member toward the transport. Downstream of the doubles detector are a pair of carry away rolls 86. The carry away rolls are operative to engage sheets that have moved sufficiently away from the stack so as to engage the rolls. The rolls which are operated by a drive in response to the controller 22, operate to engage sheets and move them into the transport. It should be understood that this

configuration of the dispenser mechanism is exemplary and in other embodiments different configurations may be used.

As discussed in the incorporated disclosure of U.S. Patent No. 5,577,720, the normal operation of the dispenser mechanism involves the picking member rotating responsive to the controller 22 during picking operations. When it is desired to pick the end note 78 the picking member 72 rotates in a counterclockwise direction as shown in Figure 14 about the axis 74. This is done through operation of a drive or other similar device. Rotation of the picking member urges the end note 78 to move from the stack. The stripping members 82 resist the movement of the end note because the stripping members do not move in a clockwise direction as shown in Figure 14. Because of the surface area of the picking member 72 engaging the end note and the frictional properties of the outer bounding surface 80, the force urging the end note 78 to move from the stack generally overcomes the resistance force of the stripping members. This is because the stripping members have a smaller surface area and/or a different frictional coefficient resulting in less resistance force than the moving force of the picking member. The stripping members however provide sufficient resistance to resist generally all but the end note 78 from moving from the stack. This is because the notes in the stack other than the end note, are not directly engaged with the picking member and do not experience the same degree of force urging them to move from the stack.

As the end note 78 is moved from the stack the thickness thereof may be sensed by the doubles detector 84. The doubles detector 84 is operatively connected to the controller and at least one signal from the doubles detector provides an indication as to whether a single or a multiple note has been pulled from the stack. In circumstances where multiple notes are sensed, the controller may cause the picking member to operate to stop rotating in the counterclockwise direction as shown in Figure 14, and instead to rotate in a clockwise direction. When the picking member 72 rotates in a clockwise direction to pull sheets back into the stack 42, the stripping members 82 are

enabled to cooperatively rotate in a counterclockwise direction as shown in Figure 14. This is due to the one-way clutch associated with each of the stripping members. As a result the sheets are returned to the stack. Thereafter the controller 22 may again operate so as to rotate picking member 72 in a counterclockwise direction and an attempt is again made to pick a single end note from the stack.

In circumstances where the doubles detector 84 senses only a single note passing from the stack, the controller operates a drive or other suitable moving mechanism to cause the carry away rolls 86 to engage and move the sheet to the transport 54. It should be understood that the steps described as being taken responsive to operation of the controller are exemplary. In some embodiments of the invention the controller may cause the machine to operate to direct double notes to a divert bin or other storage area rather than attempting to repeatedly pick a single note.

The picking member of the exemplary embodiment of the present invention is shown in greater detail in Figures 2 and 3. The picking member 72 includes a central shaft 88. Three separated cylindrical portions are supported on the shaft. These cylindrical portions include a central portion 90. Disposed on a first axial side of cylindrical portion 90 is a first outboard portion 92. Disposed in an opposed axial direction from central cylindrical portion is a second outboard portion 94.

As shown in Figure 3 each cylindrical portion 90, 92 and 94 has an associated one of the stripping members 82 in abutting relation therewith, indicated 96, 98 and 100 respectively. Each of the stripping members has an associated one-way clutch 102, 104 and 106 operatively connected therewith. Each of the one-way clutches as previously discussed, enables only one-way rotation of the stripping member. The stripping member is enabled to rotate only when sheets are being pulled back into the stack. However when sheets are being picked the stripping members remain generally stationary.

As shown schematically in Figure 3, shaft 88 is operatively connected with a drive 108 which selectively rotates the shaft responsive to signals from

the controller. As also shown in Figure 3, in the exemplary embodiment stripping member 96 which is in abutting relation with the central portion 90 is somewhat angularly disposed from stripping members 98 and 100 which are in abutting relation with the outboard portions 92 and 94 respectively. In the  
5 exemplary form of the invention, stripping member 96 is disposed somewhat angularly forward of the other stripping members such that notes tend to engage the central stripping member during picking prior to engaging stripping members 98 and 100. Of course in other embodiments of the invention other approaches, configurations and types of stripping members  
10 and picking members may be used.

As shown in Figure 2 the outer bounding surface 80 of the picking member includes an outer surface 110 of cylindrical portion 90, as well as outer surface 112 of cylindrical portion 92 and outer surface 114 of cylindrical portion 94. Outer surface 110 includes thereon a ribbed relatively high  
15 friction portion 116. The balance of the outer surface 110 has a relatively lower friction portion 118. High friction portion 116 applies an engaging force to the end note bounding the stack which is generally sufficient to engage and move the end note from the stack. The low friction portion 118 is generally enabled to move relative to the end note without causing the note to  
20 be moved from the stack. In the exemplary embodiment this construction facilitates reliably picking a single note each time the picking member is rotated one turn. This construction further provides spacing between notes sequentially picked from the stack. Such spacing facilitates identifying and handling of notes.

25 Outer surface 112 of cylindrical portion 92 likewise includes a ribbed, relatively high friction portion 120 on the outer surface thereof. Outer surface 112 also includes a relatively lower friction portion 122 which surrounds the high friction portion. The angular position of high friction portion 120 generally corresponds to high friction portion 116 on the central portion 90.  
30 As is the case with the other relatively high and low friction portions, high friction portion 120 applies force to the end note generally sufficient to engage

and move it from the stack, while the relatively lower friction portion is enabled to move in engagement with the end note without causing it to be disposed from the stack. Similarly as shown in Figure 2 cylindrical portion 94 also includes a generally high friction portion 124 and a generally lower  
5 friction portion 126. The high and low friction portions on the cylindrical portion 94 angularly correspond to the high and low friction portions on the other cylindrical portions of the picking member.

As most clearly shown in the partial cross sectional view in Figure 3, within the high friction portion 120 of cylindrical portion 92, is an arcuate  
10 segment 128. Arcuate segment 128 occupies a portion of the axial width of the cylindrical portion toward the outboard side of the picking member. The arcuate segment 128 is supported on a movable member 130. Movable member 130 as later discussed in detail, is movable relative to the cylindrical portion and the picking member in a manner which enables arcuate segment  
15 128 to move radially outward relative to the bounding surface bounding the picking member. In the exemplary form of the invention the cylindrical portion 92 is generally I-shaped in transverse cross section and includes a central web portion 132. The web portion 132 terminates in cross section in a flange portion 134 which supports the outer surface 112 thereon. The  
20 movable member 130 is movable in a recess 136 on a first longitudinal side of the web member 132.

A cam 138 is positioned in a recess 140 which extends on opposed longitudinal side from recess 136. Cam 138 is in supporting connection with the shaft 88. Cam 138 is also in supporting connection with a support member  
25 portion 142. The support member portion 142 operates to hold the cam 138 stationary as the shaft 88 and cylindrical portion 92 rotates.

Cylindrical portion 94 includes structures which are generally a mirror image of those associated with cylindrical portion 92. The high friction portion of outer surface 114 includes an arcuate segment 144 which is  
30 supported on a movable member 146. The movable member 146 is positioned in a recess 148 which is bounded by a web portion 150 and a flange portion

152 of cylindrical portion 94.

A cam 154 is positioned in a recess 156 on an opposed longitudinal side from recess 148. Cam 154 is in supporting connection with the shaft 88 and is held stationary relative to the shaft by a support member portion 158.

5 As the operation of the cylindrical portions 92 and 94 of the picking member are similar, an explanation of the operation of the picking member will be described with reference to cylindrical portion 94. As best seen in Figure 4, the segment 144 extends through an opening 160 in the flange portion 152 of cylindrical portion 94. The exemplary movable member 146 is  
10 generally horseshoe shaped and is supported on the picking member through a pivot connection 162. The pivot connection supports the movable member 146 through the web portion 150.

The cam 154 is bounded by a cam surface 164. A cam follower portion 166 is supported on the movable member 146 at an end opposed of the  
15 arcuate segment 144. The cam follower portion extends through an opening 168 in the web portion 150. This enables the cam follower portion 166 to engage the cam surface 164 of the cam 154. As can be appreciated, this arrangement enables the position of the arcuate segment 144 to be controlled as the picking member rotates due to the engagement of the cam follower 166  
20 with the cam surface 164.

The overall operation of the exemplary picking member 72 is explained with reference to Figures 5 and 6. As indicated in Figure 5, during normal operation of the picking member the high friction portions on the picking members engage an end note 78 bounding the stack. The high friction  
25 portions move the note generally engaged and at the same speed as the picking member, past the stripping member 82 so that the end note is moved from the stack. During this normal operation the note moves in synchronized relation with the movement of the outer bounding surface 80 of the picking member 82. As a result during normal operation the velocity of the end note indicated  
30 by arrow N corresponds generally to the velocity of the outer surface 80 of the picking member represented by arrow P. Arrow F corresponds to the

direction of the force applied to the stack which holds the end note 78 in engaged relation with the picking member 72.

Figure 6 represents the operation of the picking member 72 of the exemplary embodiment when an end note 78 fails to move in coordinated  
5 relation with the picking member. In such circumstances the velocity and displacement of the picking member is greater than the corresponding velocity and movement of the end note 78. The high friction arcuate segments 128,  
144 which serve as engaging portions, because they are enabled to move relative to the picking member 72, tend to maintain engaged relation with the  
10 end note. This is represented by the arcuate segment 144 in Figure 6. Because the engaging portion of the arcuate segment 144 remains engaged with the end note and is movable relative to the picking member, when the angular movement of the picking member exceeds the movement of the engaging portion of segment 144, the segment 144 moves radially outward  
15 relative to outer bounding surface 80. The movement of the engaging portion further radially outward relative to the axis of rotation 174 increases the engaging force on the end note urging it to move from the stack. As can be appreciated from the later detailed description of the movable member, the engaging portions tend to move further radially outward providing increasing  
20 engaging force, with an increase in difference between the movement of the picking member and the engaging portion. This increasing force on the end note tends to cause the end note to begin moving past the stripping members 82 so that the note can be picked. As the end note begins to move in coordinated relation with the picking member, the engaging portions may  
25 begin to move radially inward. In the exemplary embodiment the action of the cam follower portion and the cam surface operate to assure that the engaging portions are moved radially inward to the level of the outer bounding surface 80 by the time the engaging portions rotate to a position adjacent to the stripping members 82. This assures that the engaging portions  
30 and the notes are not damaged.

Figures 7-10 show the exemplary operation of the picking member 72

with regard to cylindrical portion 94 of the picking member. It should be understood that cylindrical portion 92 is a mirror image thereof and works in a similar manner during picking. As represented in Figure 7, the picking member 72 rotates in the direction of arrow P. Assuming that an end note engaged with the engaging portion which is included on segment 144 is not moving in synchronization with the picking member, the segment 144 rotates in a first direction about pivot connection 162. This results because the segment 144 is engaged with the note and the angular movement thereof does not correspond to the angular movement of the picking member 72 about the axis 74. Segment 144 moves radially outward relative to axis 74. The radially outward movement of segment 144 is limited by the engagement of the cam follower portion 166 with the cam portion 164 of cam 154.

As can be appreciated, the outward movement of the engaging portion on segment 144 applies increasing engaging force on the end note responsive to the end note not moving with the picking member. In addition the engaging portion of segment 144 operates to move further radially outward with an increasing difference between the movement of the picking member and the movement of the note. This outward movement may continue until the segment 144 reaches the full extent of its travel as limited by the cam surface.

As shown in Figure 8, if the end note has not initially moved in coordinated relation with the picking member, the engaging portion of the arcuate segment 144 will generally remain extended radially outward relative to the outer bounding surface of the picking member as the picking member further rotates. This provides additional force tending to assure that the note is moved from the stack. It should be appreciated that once the note begins moving, if note movement begins to exceed that of the picking member, the engaging portion of the arcuate segment 144 will begin to retract radially inward toward the outer bounding surface 80. Generally however once the engaging portion has extended radially outward, it will remain outwardly extended to the extent permitted by the engagement of the cam follower portion 166 with the cam surface 164.

As shown in Figure 9, as the picking member 72 rotates further toward the position where the engaging portion of the arcuate segment 144 approaches the stripping members, the profile of the cam surface 164 causes the cam follower portion 166 to cause the movable member 146 to rotate relative to the pivot connection 162. As shown in Figure 9 the cam surface tends to rotate the movable member 146 in a generally opposed rotational direction about pivot connection 162, a direction in which the movable member rotates to extend the arcuate segment. As a result, as the picking member rotates so that the arcuate segment approaches the stripping member, the arcuate segment tends to move radially inward toward the outer bounding surface 80.

As shown in Figure 10 once the picking member 72 has rotated to the point where the engaging portion of segment 144 is in abutting relation with the stripping member, the operation of the cam surface 164 and the cam follower portion 166 has caused the engaging portion to be retracted through movement of the movable member 146. The outer surface of segment 144 at this point is moved to generally conform with the outer bounding surface 80 of the picking member. In addition as the engaging portion on the segment 144 retracts radially inward, the engaging portion applies a decreasing engaging force to the end note as the end note is moved between the picking member and the stripping member. This decreasing force not only avoids collisions between the engaging portion and the stripping members, but it also prevents possible damage to the mechanism as well as to the notes being picked.

As shown in Figure 10 the exemplary form of the invention includes a stop portion 170 on the movable member 146. The stop portion 170 engages a surface 172 bounding recess 148. The stop portion prevents the engaging portion on the segment 144 from being moved radially inward substantially beyond the outer bounding surface 80 of the picking member.

As can be appreciated this exemplary embodiment of the picking member provides increasing engaging force on the end note responsive to the

end note not moving with the picking member. As a result additional picking force is applied in only those circumstances where it is required to move the end note from the stack. In circumstances where notes are soiled, have high surface tension or are of slippery consistency, additional moving force is usually automatically applied. Further the exemplary form of the picking member also enables compensating for wear or reduced friction with soiling that may result from extended use of a picking member. In this way the exemplary form of the picking member is able to compensate for those conditions which might otherwise result in a decrease in note picking reliability.

It should further be understood that while in the exemplary form of the picking member the engaging portion is moved radially outward and applies additional picking force based on the relative movement between the end note and the picking member, in other embodiments other approaches may be used. Such approaches may include for example, other devices and systems for determining a difference in relative movement between the notes being picked and the picking member, and moving in engaging portion to apply additional engaging force in response thereto. Although the exemplary form of the invention uses a mechanical type system to accomplish this, electronic and electromechanical systems may be used in other embodiments.

A further useful aspect of the exemplary form of the picking member and its operation in connection with dispensing mechanisms, is that it may be readily retrofit to an existing automated banking machine. The exemplary form of the invention enables a service technician to access an interior area of an ATM such as by unlocking a door to a secure chest portion. Once access is gained to the note handling mechanism, the technician may remove an existing picking member which does not include the features of the radially movable engaging portions, and to install a picking member 72 in place thereof. In the exemplary form of the invention the support member portions 142 and 158 are configured to engage existing surfaces within the housing of the ATM so as to hold the cams stationary as the picking member rotates.

Once installed in the ATM, the door to the secure chest portion is closed and locked.

Picking member 72 is constructed to have the same general profile as picking members that do not incorporate the exemplary form of the present invention. Thus installation of the exemplary picking member is readily made to improve the operation of the machine. It should further be understood that the programming of the controller 22 also often need not be changed to accommodate the installation of the picking member 72. Except as described herein, the operation of the picking member 72 is similar to that of a picking member which may be replaced in terms of moving and retracting notes.

In the exemplary embodiment of the invention a note transport such as note transport 54, includes features to reduce the risk that notes may become stuck or jammed in the transport. As previously discussed in connection with Figure 1, note transport 54 includes a plurality of continuous belts 56 which extend about sets of rollers 58. It should be understood that the transport 54 may include belts that extend the entire length of the transport or may have several belts which span sections of the transport. In an exemplary form of the present invention the continuous belts are arranged so that the transport includes a plurality of generally parallel belt flights. These belt flights are represented in Figure 12 by belt flights 174, 176 and 178. Each of the belt flights extend along a longitudinal direction of the transport, in which longitudinal direction sheets are moved. The belt flights are moved through operation of a drive or similar moving mechanism which is controlled responsive to operation of the controller 22 and which drives the rollers upon which the belts are supported.

As shown in Figure 12, disposed transversely intermediate of each adjacent pair of belt flights, are projecting member portions 180, 182. As can be readily seen from Figure 12, each of the belt flights has a first sheet engaging surface represented by surface 184 of belt flight 174, which faces in a first facing direction toward a sheet 186 which extends in the transport. The projecting member portions each include a second sheet engaging surface

represented by surface 188 of projecting member portion 180. The second sheet engaging surface 188 faces in a second facing direction which is generally opposed of the first facing direction. As will be appreciated the first and second facing directions in which the sheet engaging surfaces of the belt flights and the projecting member portions extend respectively, are both generally normal of the longitudinal direction in which the sheets move.

As can be appreciated from Figures 12 and 13, the configuration of the first belt flights and the sheet engaging member portion is such that a sheet that is moved into intermediate relation between the first sheet engaging surface of the belt flights and the second sheet engaging surfaces of the projection member portions, is deformed in a wavelike configuration so that the sheet is engaged with the belt flights. As a result when the belt flights move, the sheet 186 moves in engagement therewith.

As can be appreciated from Figure 14, the sheet transport 54 is enabled to accept sheets such as a sheet 190 through openings such as opening 192. As can be appreciated, from Figure 14, a sheet passing through the opening in the projecting member portions moves in engagement with the first belt flights to become trapped in sandwiched relation between the belt flights and the projecting member portions. The sheet once trapped in this manner is caused to be moved along with the belt flights to a desired location within the machine responsive to signals from the controller.

As mentioned previously, occasionally sheets such as bank notes become stuck in transports of this type. This may result due to various conditions which prevent the notes from moving in coordinated relation with the belt flights. In the exemplary embodiment of the present invention, conventional type belts which have in the past been used in transports of this type are replaced with alternative belts which reduce the risk that sheets will become stuck. Specifically while prior belts have a generally smooth continuous sheet engaging surface, the alternative belts used in the exemplary form of the present invention include at least one longitudinally spaced projection which extends in the first facing direction from the sheet engaging

surface of the belt. In a more preferred exemplary form of the present invention such longitudinally spaced projections extend at spaced intervals on the first sheet engaging surface of the belt. The presence of such longitudinally spaced extending projections engage sheets that might otherwise not move in the transport and move them to the desired location.

Figure 11 shows an isometric view of belt flight 174 with the first sheet engaging surface 184 thereof turned 180 degrees from that shown in Figure 13. The first sheet engaging surface 184 includes a plurality of longitudinally spaced projections 194. The projections 194 extend generally in the first facing direction represented by arrow 196. In the exemplary form of the invention, the projections 194 are deformable, resilient and spaced from one another a distance that is greater than the length of the sheets that are moved through the associated transport in the longitudinal direction. This enables a sheet to extend between the adjacent longitudinally spaced projections. It should be understood however that other embodiments of the invention may have projections with other properties and the projections spaced more closely together. Other alternative embodiments of the invention may have the projections spaced far apart, even to the extent of including only one such projection on the continuous sheet engaging surface of a belt.

In embodiments of the invention all of the belts used in connection with a transport may include projections thereon. However in some embodiments it may be desirable only to replace certain belts with alternate belts including such projections. For example in the transport including three belt flights shown in Figure 13, it may be desirable only to replace the middle belt with an alternate belt. Alternatively it may be desirable to replace the two outward belts with an alternate belt, leaving the middle belt as having a generally smooth continuous outer surface. Various approaches to replacing the belts may be taken depending on the particular type of documents being transported.

As shown in Figure 13 embodiments of the invention may have multiple belts arranged such that the projections that extend from the first

sheet engaging surfaces of the belts are generally transversely aligned. In this way each of the longitudinally spaced projections will maintain generally the same spaced relation relative to the other projections as the belts are moved from the transport. Alternate embodiments of the invention may have the belts installed such that there is no predetermined relationship between the projections on each respective adjacent belt. In each situation benefit is obtained as the projections facilitate movement of sheets in the transport.

It should be understood that the configuration of belt flight 74 with the longitudinally spaced projections which extend across the first sheet engaging surface of the belt is exemplary. In other embodiments of the invention other types of projection configurations may be used. For example, Figure 15 shows a belt flight 198. Belt flight 198 includes bubble type projections 200. Figure 16 shows a further alternate belt flight 202 which has adjacent cone-like projections 204. Figure 17 shows yet a further alternate belt flight 206. Belt flight 206 includes ramp-like projections 207. It should be understood that these belt and projection configurations are exemplary and in other embodiments other configurations may be used.

The exemplary form of the transport improvements of the present invention is designed for use in connection with existing transports which move sheets such as bank notes in an automated banking machine. Belts which include the improvement are made to extend about existing sets of rollers within the machines and to replace existing transport belts which have generally smooth continuous sheet engaging surfaces about the entire periphery thereof. To improve the performance of the transports in such machines, a service person must open the housing of the machine such as by unlocking and opening a door of a secure chest. The service person is then enabled to remove the existing transport belt from a set of rollers which support and move such belt. With the prior belt removed from the transport, an alternative belt of one of the types described herein including longitudinally spaced projections is installed in supporting connection with the set of rollers. The service person may then close and lock the door of the

secure chest of the ATM. Sheets may be then moved in the transport urged not only by the relatively smooth portions of the sheet engaging surface of the belt, but further urged to move by engagement with the projections thereon. As can be appreciated, the projections on the belts provide additional urging force that is generally sufficient to move sheets that otherwise might slip or become stuck in a transport.

It should be appreciated that in the exemplary embodiment, the alternate belts described may be used in connection with transport 54 as well as transport 60. The principles of the invention may also be applied to other devices which move sheets within the machine. For example belts which include longitudinally spaced projections of the type described herein may be used in connection with a system for moving stacks of sheets such as is shown in U.S. Patent No. 5,507,481.

In such transports the projecting member portions comprise moving belt flights which move in coordinated relation with the facing belt flights and serve to transport stacks in between. Alternative belts including projecting portions thereon may be used to move stacks of sheets that are in between and enable movement of such stacks more reliably. As is explained in the incorporated disclosure, such transports in which the projecting member portions comprise moving belt flights enable reliably moving stacks of notes or connected sheets such as passbooks and checkbooks within an automated banking machine.

The principles of the present invention may also be applied to other types of stack and sheet transports including for example, stack accumulation and presentation mechanisms such as is found in U.S. Patent No. 5,435,542, the disclosure of which is also incorporated herein by reference as if fully rewritten herein. Of course the principles of the invention may be applied to other transport mechanisms as well. It should be understood that the improved sheet dispensing functions achieved through utilization of the principles of the present invention may be incorporated in automated banking machines with the improved transport features to achieve improved reliability

in moving and delivering sheets within the automated banking machine. Of course it should also be understood that in some embodiments the improved picking capabilities will be implemented without the improved transport capabilities and vice versa. The principles of the invention may also be applied to other configurations of picking members and devices as well as sheet transports.

Thus the new and improved automated banking machine features of the present invention achieve at least one of the above stated objectives, eliminate difficulties encountered in the use of prior devices and systems, solve problems and attain the desirable results described herein.

In the foregoing description certain terms have been used for brevity, clarity and understanding, however no unnecessary limitations are to be implied therefrom because such terms are used for descriptive purposes and are intended to be broadly construed. Moreover, the descriptions and illustrations herein are by way of examples and the invention is not limited to the details shown and described.

In the following claims any feature described as a means for performing a function shall be construed as encompassing any means capable of performing the recited function, and shall not be limited to the structures shown herein or mere equivalents thereof.

Having described the features, discoveries and principles of the invention, the manner in which it is constructed and operated, and the advantages and useful results attained; the new and useful structures, devices, elements, arrangements, parts, combinations, systems, equipment, operations, methods, processes and relationships are set forth in the appended claims.

**WHAT IS CLAIMED IS:**

## 1. Apparatus comprising:

an automated banking machine including a sheet transport therein, the sheet transport including:

at least one belt flight extending in a longitudinal direction,

wherein the at least one belt flight includes a first sheet engaging surface facing generally in a first facing direction generally normal of the longitudinal direction,

wherein the first sheet engaging surface includes at least one projection extending generally in the first facing direction,

at least one longitudinally extending projecting member portion extending parallel to the at least one belt flight,

wherein the longitudinally extending projecting member portion includes a second sheet engaging surface facing generally in a second facing direction generally normal of the longitudinal direction and opposed of the first facing direction,

wherein the sheet transport is operative to move at least one sheet in the longitudinal direction in engagement with the first and second sheet engaging surfaces.

2. The apparatus according to claim 1 wherein the at least one belt flight includes a plurality of generally parallel belt flights extending in the longitudinal direction.

3. The apparatus according to claim 2 wherein each of the belt flights includes a first sheet engaging surface facing generally in a first facing direction generally normal of the longitudinal direction, wherein the at least one longitudinally extending projecting member portion includes a second sheet engaging surface facing generally

in a second facing direction generally normal of the longitudinal direction and opposed of the first facing direction, and wherein the sheet transport is operative to move at least one sheet in the longitudinal direction in engagement with the first and second sheet engaging surfaces.

4. The apparatus according to claim 3 wherein the first sheet engaging surface of at least one belt flight includes a plurality of longitudinally spaced projections extending generally in the first facing direction.

5. The apparatus according to claim 4 wherein the at least one longitudinally extending projecting member portion extends parallel to and transversely intermediate to immediately transversely adjacent belt flights.

6. The apparatus according to claim 4 wherein each projection comprises resilient material, and wherein the projections extend at predetermined spaced intervals on the first sheet engaging surface of the at least one belt flight.

7. The apparatus according to claim 4 wherein each of the first sheet engaging surfaces of the belt flights includes a plurality of longitudinally spaced projections extending generally in the first facing direction from the first sheet engaging surface.

8. The apparatus according to claim 7 wherein the projections are adapted to engage a sheet, wherein the sheet transport is operative to move at least one sheet in the longitudinal direction in engagement with at least one projection and a second sheet engaging surface.

9. The apparatus according to claim 7 wherein the plurality of longitudinally spaced projections extend at predetermined spaced intervals on each first sheet engaging surface.

10. The apparatus according to claim 9 wherein the spaced projections are equally spaced from one another.

11. The apparatus according to claim 7 wherein each spaced projection extends generally in a transverse direction generally normal of the longitudinal direction across a first sheet engaging surface.
12. The apparatus according to claim 11 wherein the belt flights comprise adjacent belt flights, wherein spaced projections on adjacent belt flights are generally aligned in the transverse direction.
13. The apparatus according to claim 11 wherein continuous belts comprise the belt flights.
14. The apparatus according to claim 4 wherein the at least one longitudinally extending projecting member portion includes a plurality of generally parallel projecting member portions extending in the longitudinal direction, wherein each projecting member portion includes a second sheet engaging surface facing generally in a second facing direction generally normal of the longitudinal direction and opposed of the first facing direction, and wherein the sheet transport is operative to move at least one sheet in the longitudinal direction in engagement with the first and second sheet engaging surfaces.
15. The apparatus according to claim 14 wherein each projecting member portion extends parallel to and transversely intermediate to immediately transversely adjacent belt flights.
16. The apparatus according to claim 15 wherein the sheet transport includes three first belt flights and two projecting member portions, each projecting member portion disposed on an alternate transverse side of one of the belt flights.
17. The apparatus according to claim 14 wherein each of the belt flights comprises a first belt flight, wherein the first belt flights are movable along the longitudinal direction, wherein at least one projecting member portion comprises at least one second belt flight, wherein the at least one second belt flight is movable along the longitudinal direction, and wherein the sheet transport is operative to move sheets in

the longitudinal direction in engagement with first belt flights and the at least one second belt flight.

18. The apparatus according to claim 17 wherein the second engaging surface of the at least one second belt flight includes a plurality of longitudinally spaced projections extending generally in the second facing direction.

19. The apparatus according to claim 18 wherein each of the projecting member portions comprises a second belt flight.

20. The apparatus according to claim 19 wherein each of the first sheet engaging surfaces of the first belt flights include a plurality of longitudinally spaced projections extending generally in the first facing direction from the first sheet engaging surface, and wherein each second belt flight extends parallel to and transversely intermediate to immediately transversely adjacent first belt flights.

21. The apparatus according to claim 1 wherein the at least one projection comprises resilient material.

22. The apparatus according to claim 21 wherein the at least one projection comprises at least one rib extending in a direction generally transverse to the longitudinal direction.

23. The apparatus according to claim 21 wherein the at least one projection comprises a conical projection.

24. The apparatus according to claim 21 wherein the at least one projection comprises a ramp shaped projection.

25. The apparatus according to claim 1 wherein the automated banking machine further comprises a sheet dispenser, and wherein the sheet transport is operative to move at least one sheet dispensed from the sheet dispenser in the longitudinal direction in the machine.

26. The apparatus according to claim 1 wherein the automated banking machine comprises an ATM, wherein the ATM includes sheets, wherein the sheets comprise currency notes, wherein the sheet transport is operative to move currency notes in the longitudinal direction in the ATM.

27. Apparatus comprising:

an automated banking machine including a sheet transport therein, the sheet transport including:

a plurality of generally parallel belt flights extending in a longitudinal direction,

wherein each of the belt flights includes a first sheet engaging surface facing generally in a first facing direction generally normal of the longitudinal direction,

wherein the first sheet engaging surface of at least one belt flight includes a plurality of longitudinally spaced projections extending generally in the first facing direction,

at least one longitudinally extending projecting member portion extending parallel to and transversely intermediate to immediately transversely adjacent belt flights,

wherein the at least one longitudinally extending projecting member portion includes a second sheet engaging surface facing generally in a second facing direction generally normal of the longitudinal direction and opposed of the first facing direction,

wherein the sheet transport is operative to move at least one sheet in the longitudinal direction in engagement with the first and second sheet engaging surfaces.

28. The apparatus according to claim 27 wherein the automated banking machine comprises an ATM, wherein the ATM comprises the sheet transport and sheets, wherein the sheets comprise currency notes, wherein the sheet transport is operative to move currency notes in the longitudinal direction in the ATM.

29. The apparatus according to claim 27 wherein each of the belt flights comprises a first belt flight, wherein the first belt flights are movable along the longitudinal direction, wherein each of the projecting members comprises a second belt flight, wherein the second belt flights are movable along the longitudinal direction, wherein the second sheet engaging surface of at least one second belt flight includes a plurality of longitudinally spaced projections extending generally in the second facing direction from the second sheet engaging surface, and wherein the sheet transport is operative to move sheets in the longitudinal direction in engagement with first belt flights and the second belt flights.

30. Apparatus comprising:

an automated banking machine including a sheet transport therein, the sheet transport including:

a plurality of generally parallel belt flights extending in a longitudinal direction,

wherein each of the belt flights includes a first sheet engaging surface facing generally in a first facing direction generally normal of the longitudinal direction,

wherein each of the first sheet engaging surfaces includes a plurality of longitudinally spaced projections extending generally in the first facing direction from the sheet engaging surface,

wherein the projections extend at predetermined spaced intervals on each first sheet engaging surface,

wherein each projection extends in a direction generally transverse to the longitudinal direction,

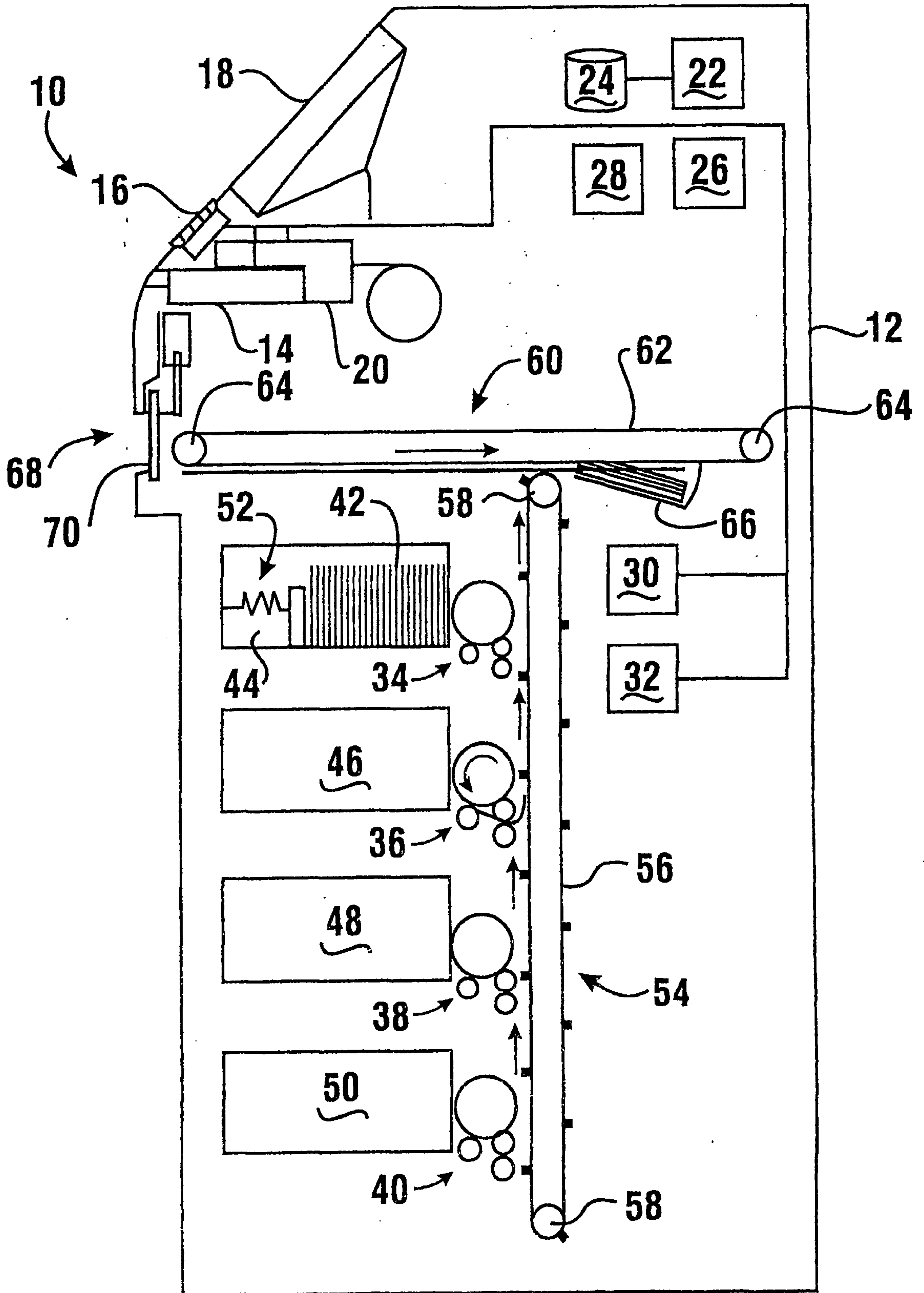
wherein each projection comprises resilient material,

a plurality of longitudinally extending projecting member portions,

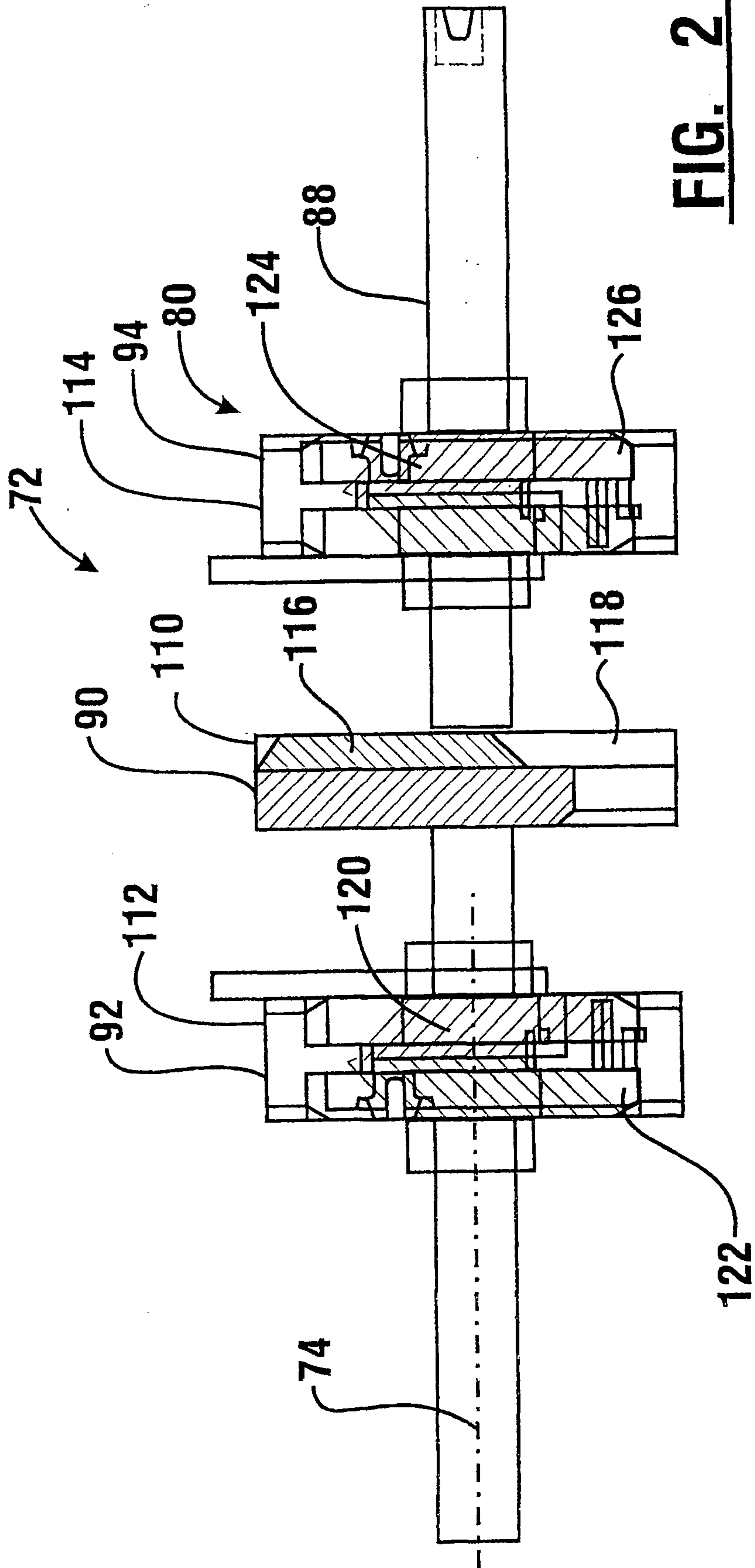
wherein each projecting member portion includes a second sheet engaging surface facing generally in a second facing direction generally normal of the longitudinal direction and opposed of the first facing direction,

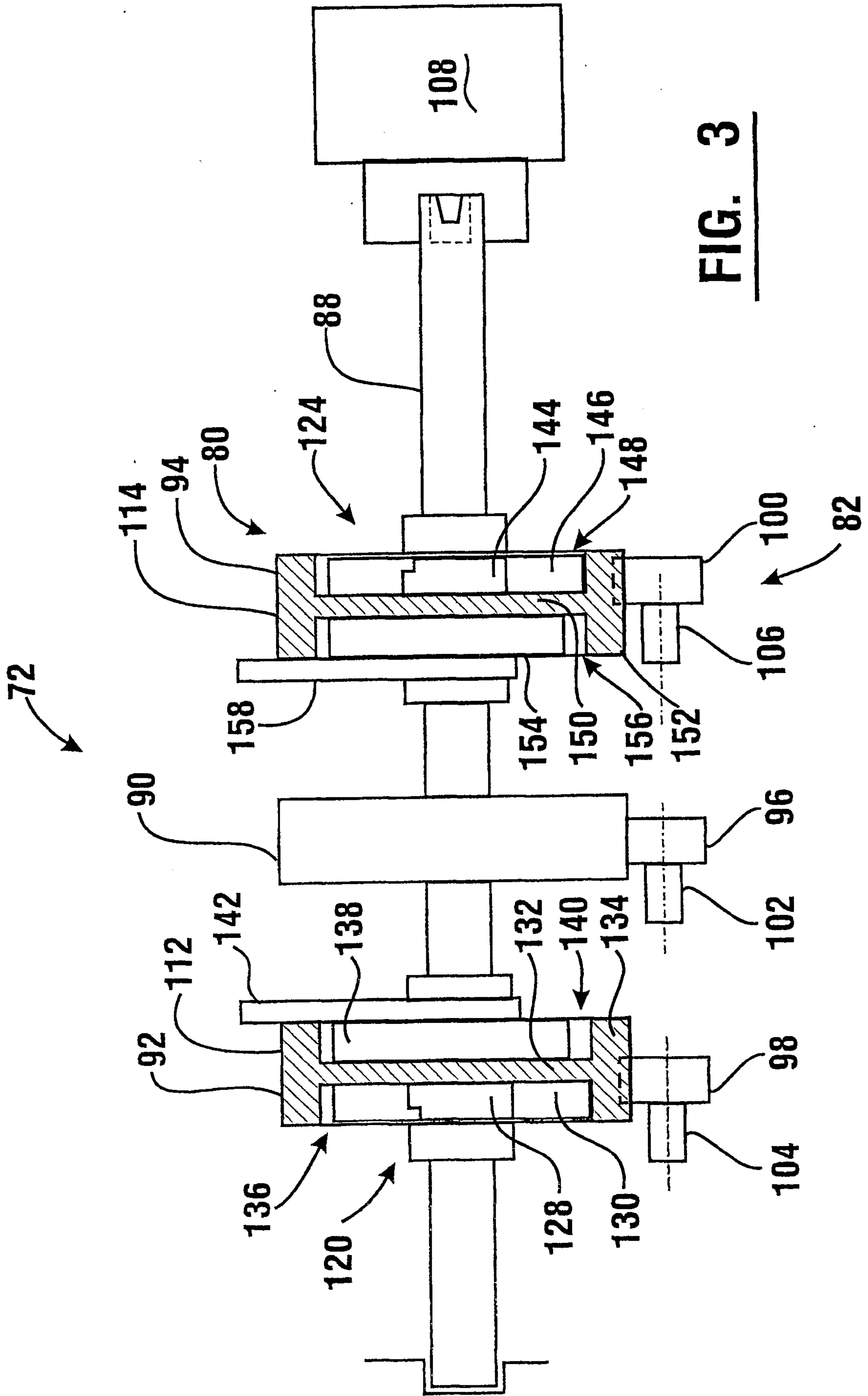
wherein each projecting member portion extends parallel to and transversely intermediate to immediately transversely adjacent belt flights,

wherein the sheet transport is operative to move sheets in the longitudinal direction in engagement with the first and second sheet engaging surfaces.

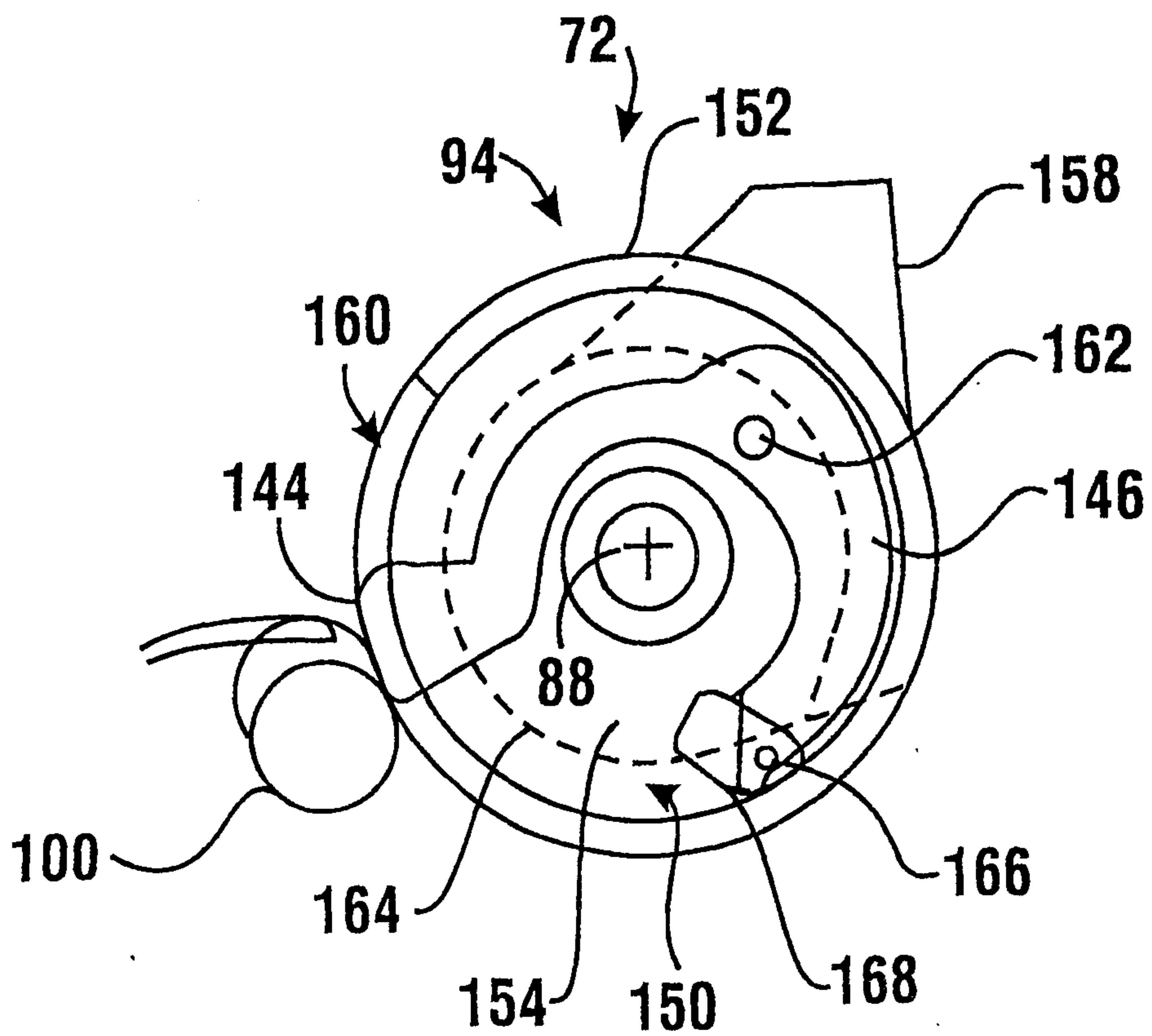


**FIG. 1**

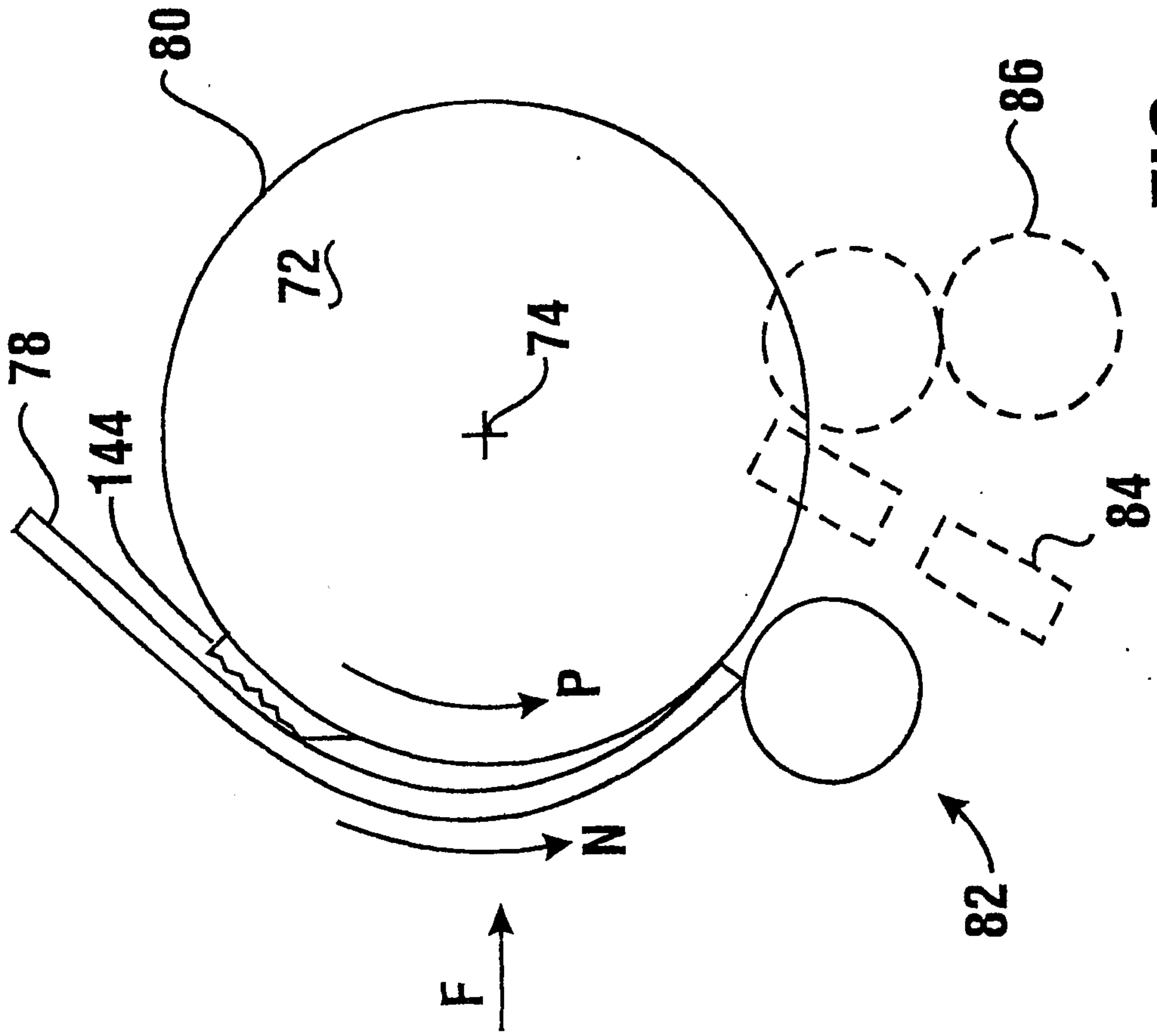




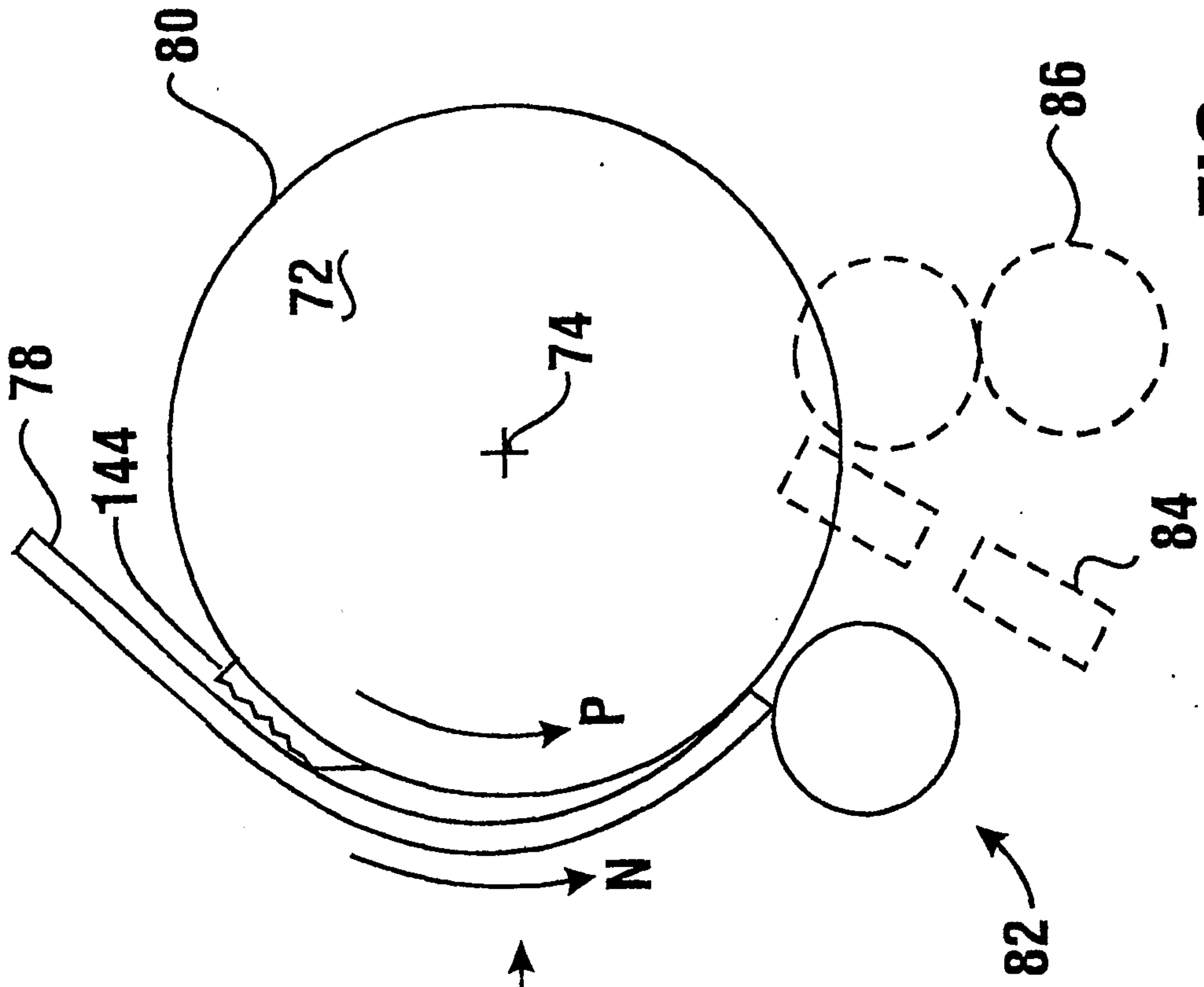
**FIG. 3**



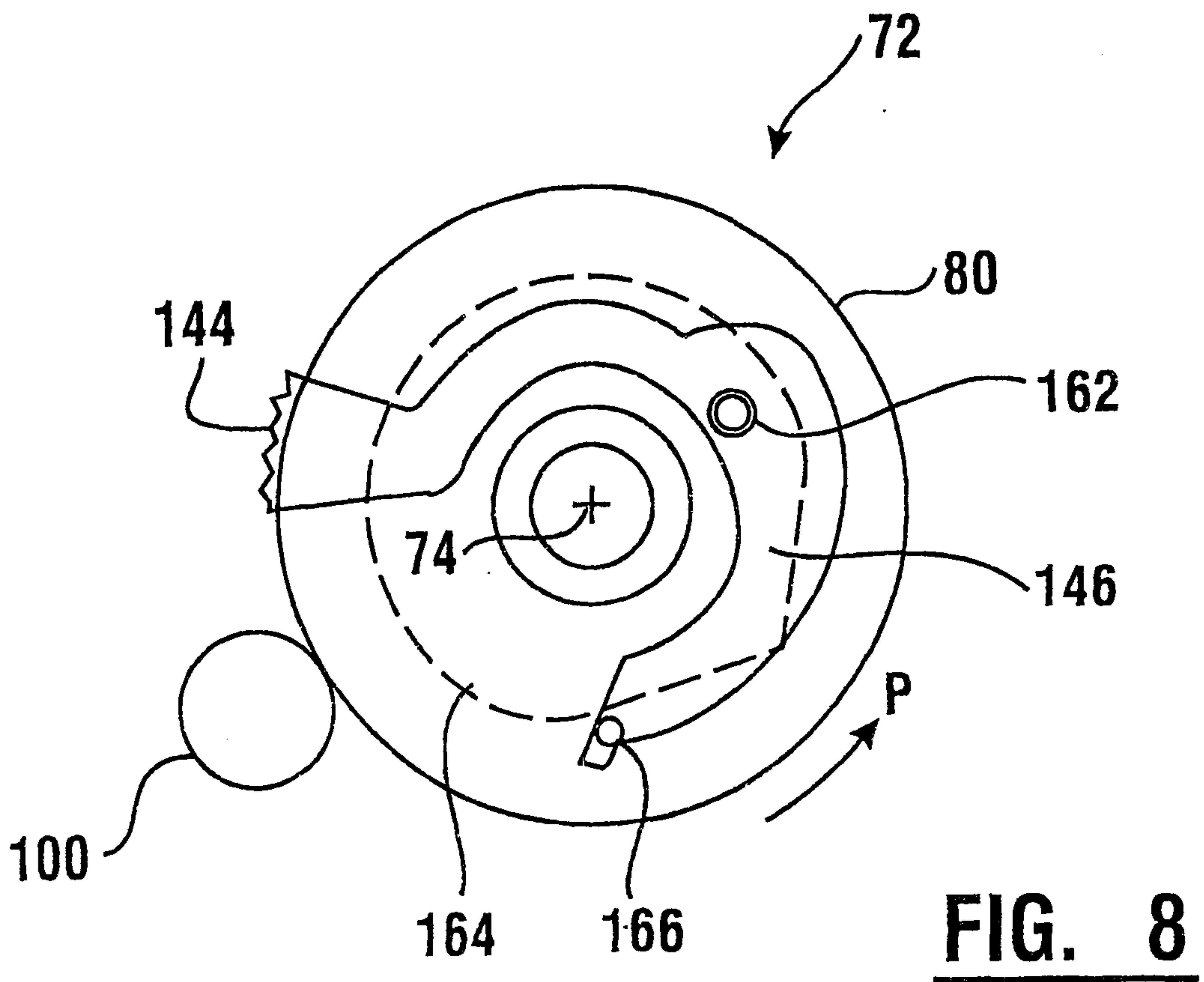
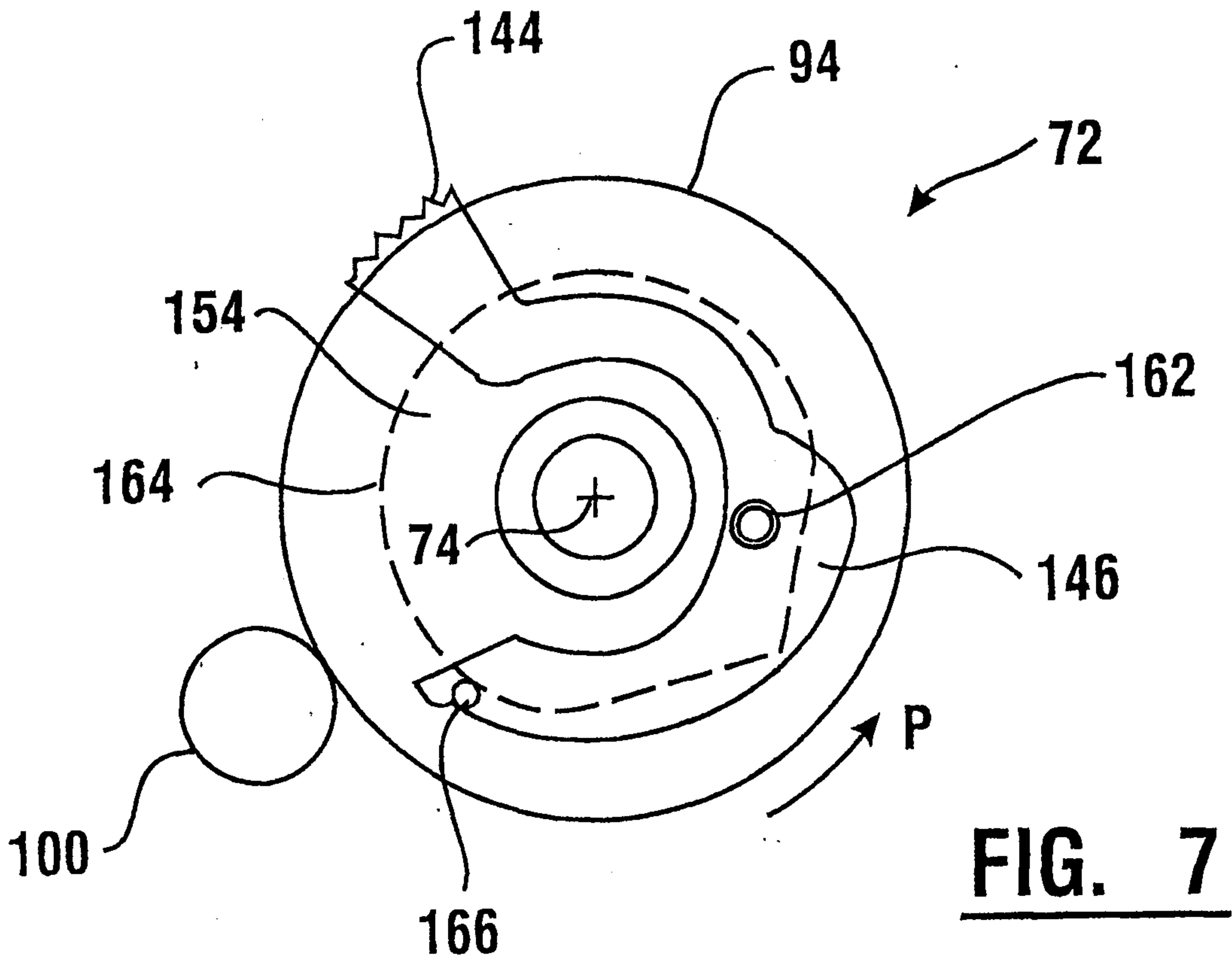
**FIG. 4**

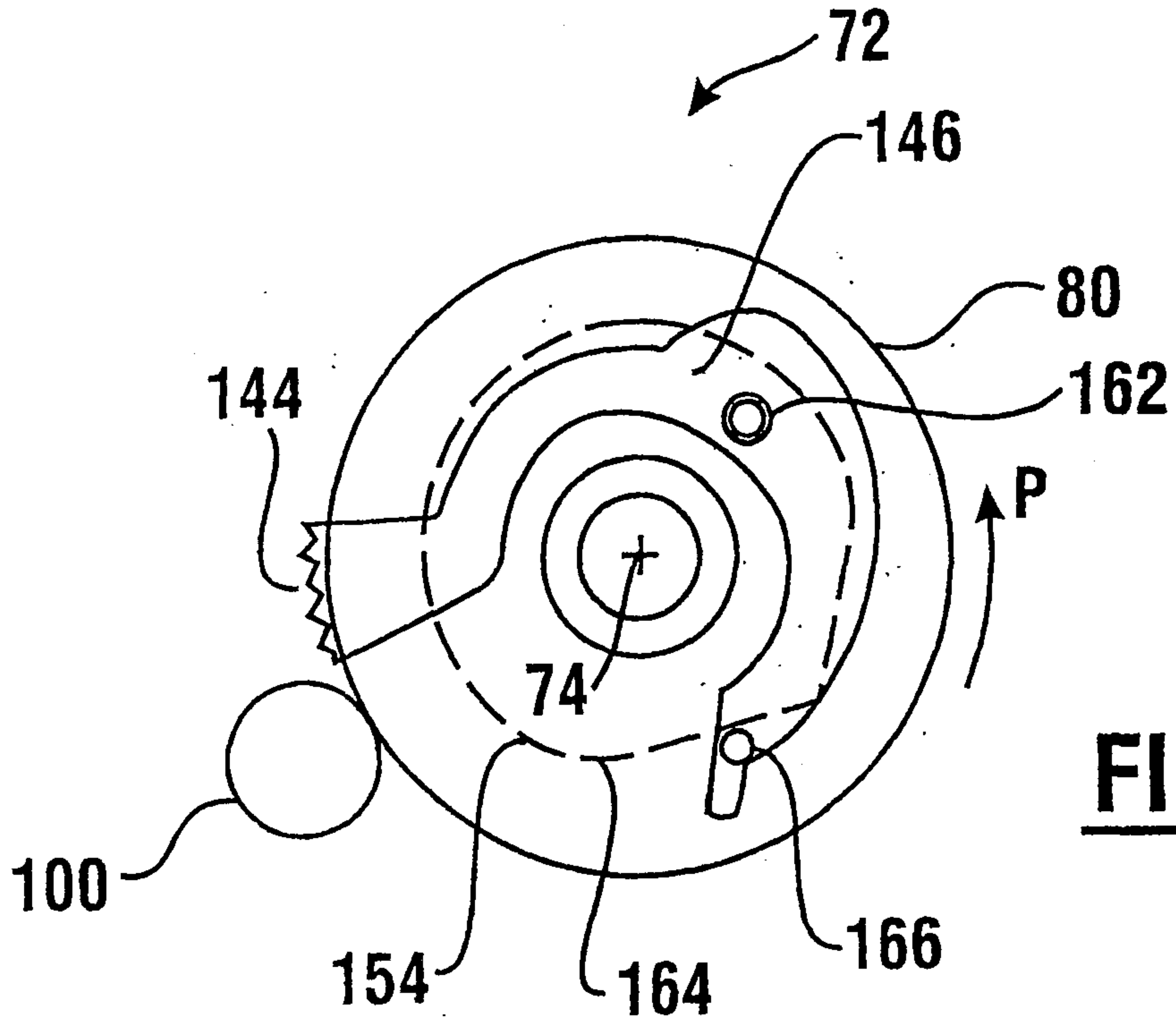


**FIG. 5**

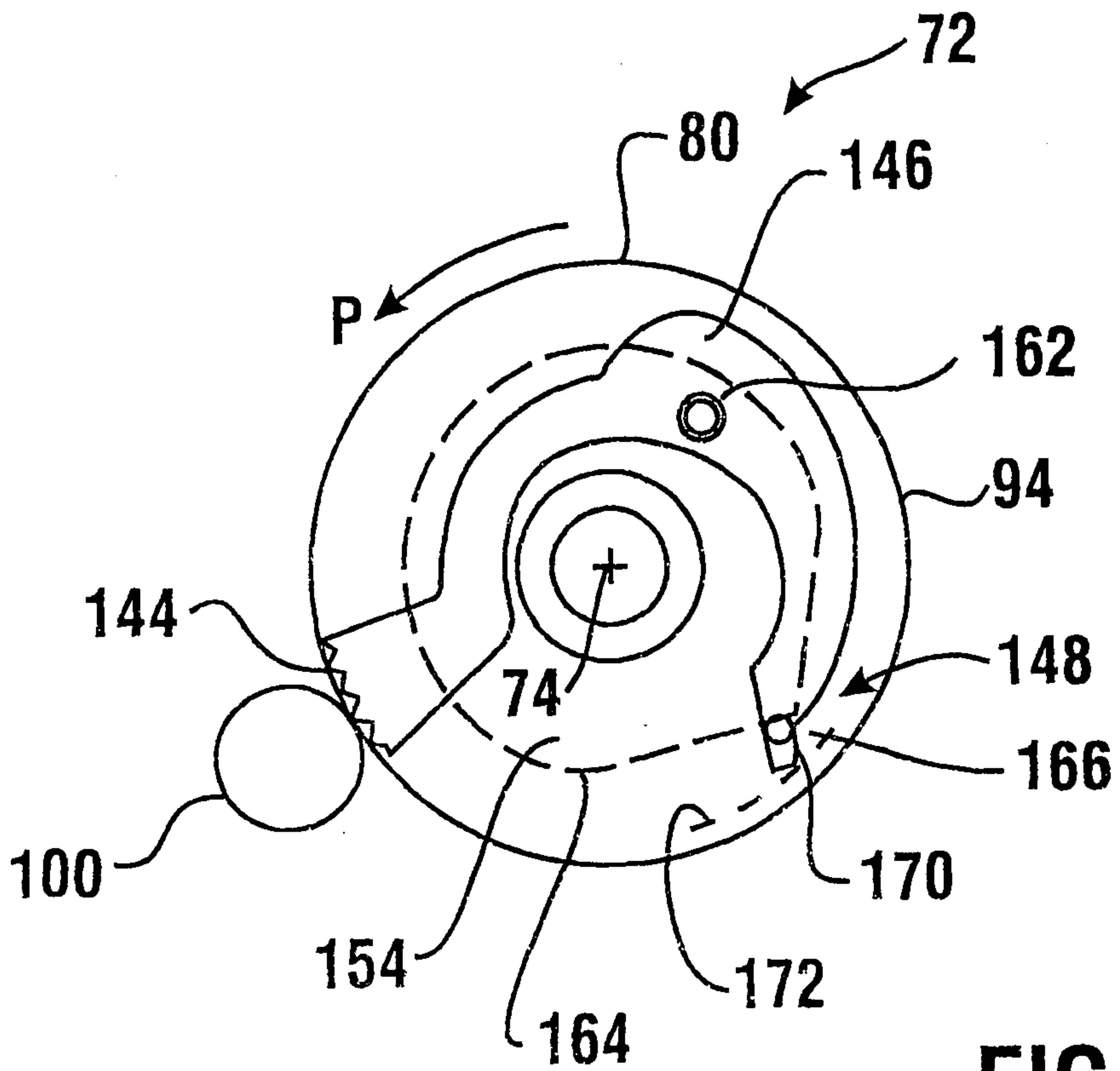


**FIG. 6**

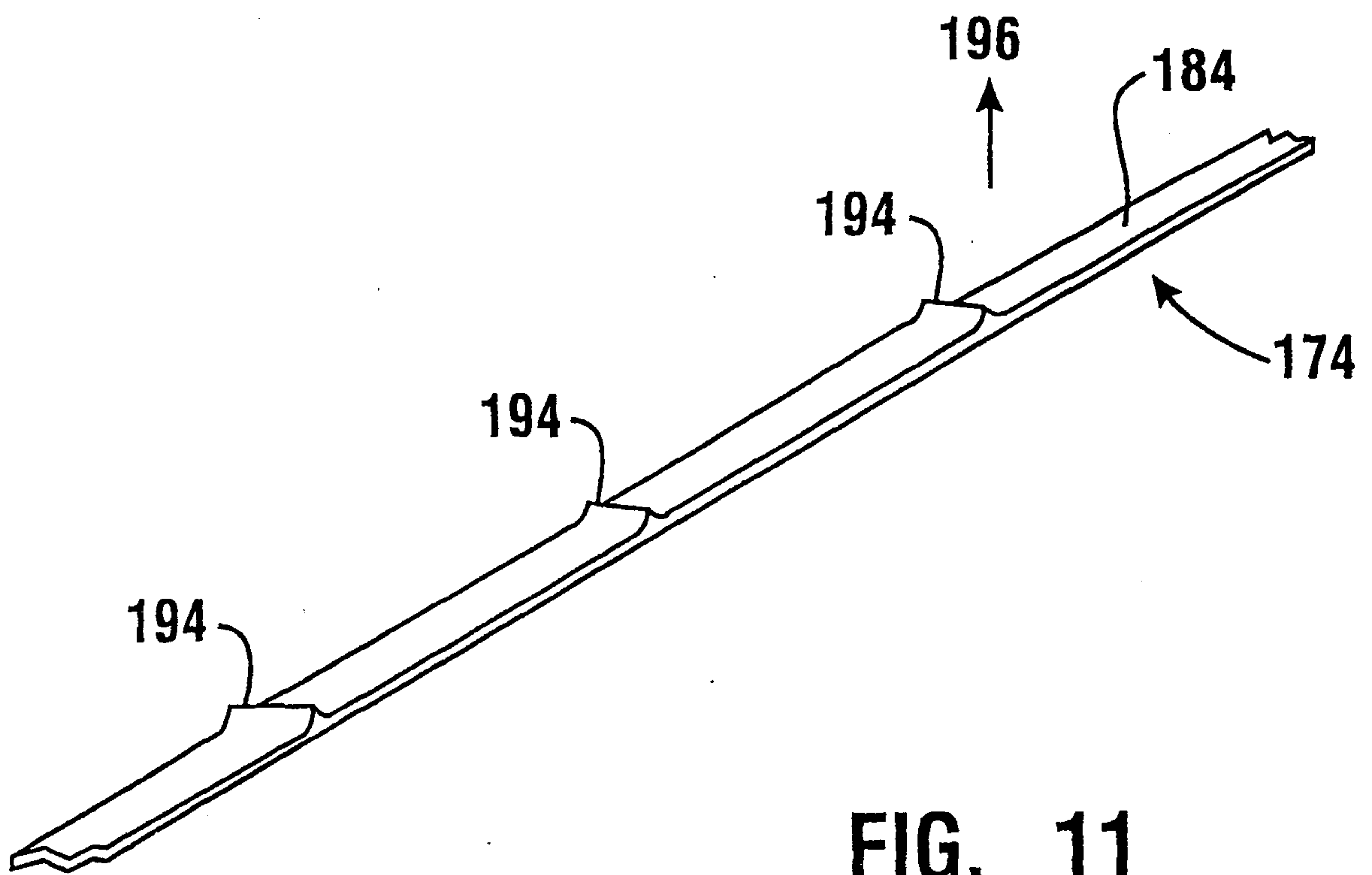




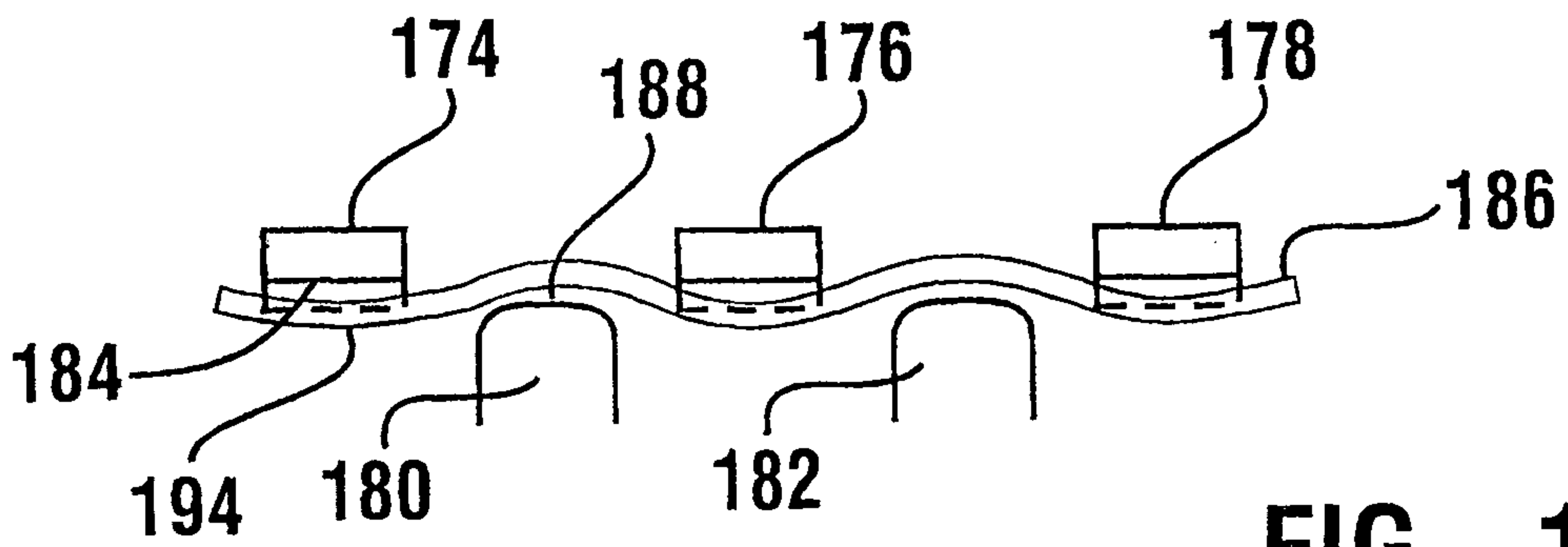
**FIG. 9**



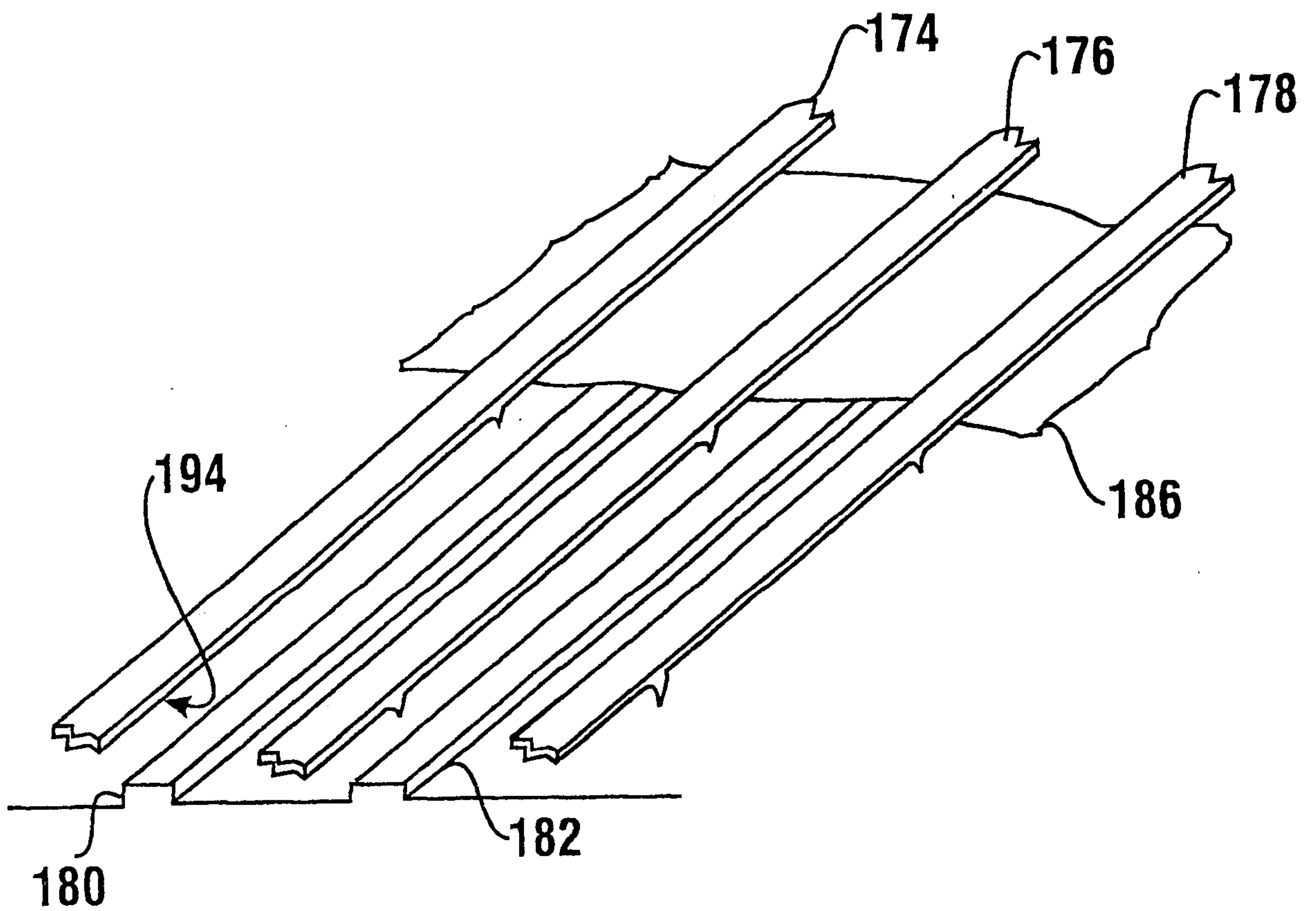
**FIG. 10**



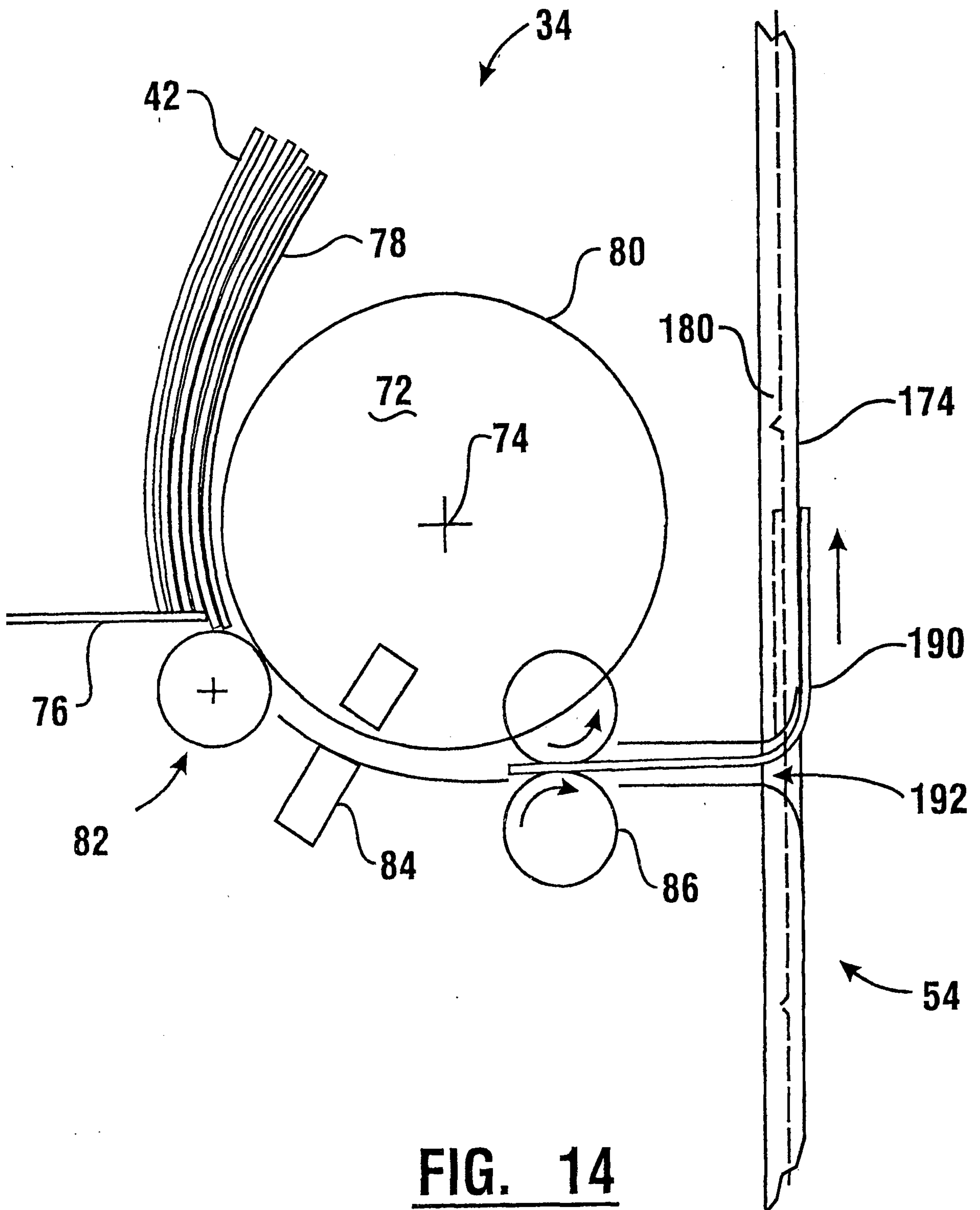
**FIG. 11**



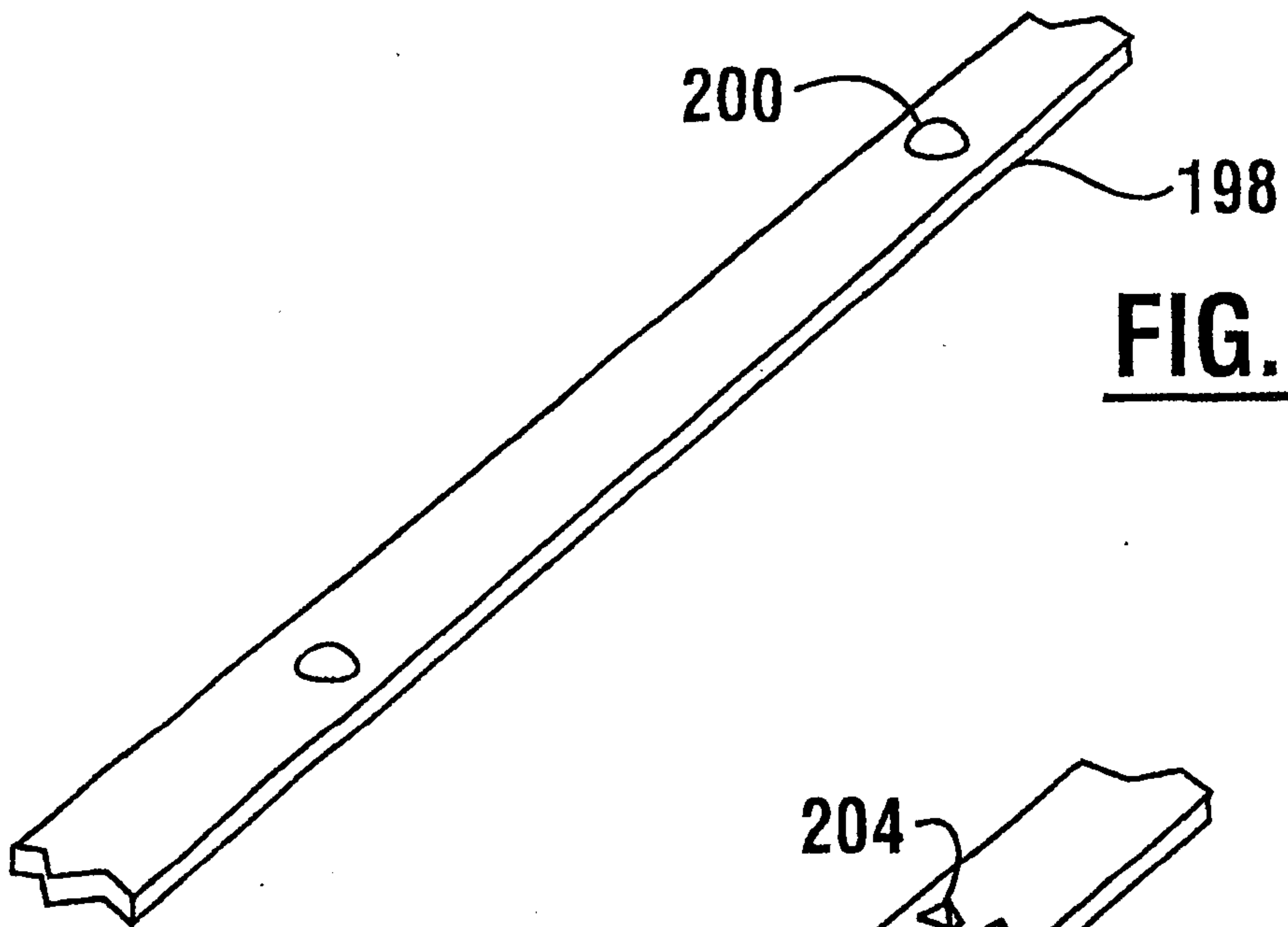
**FIG. 12**



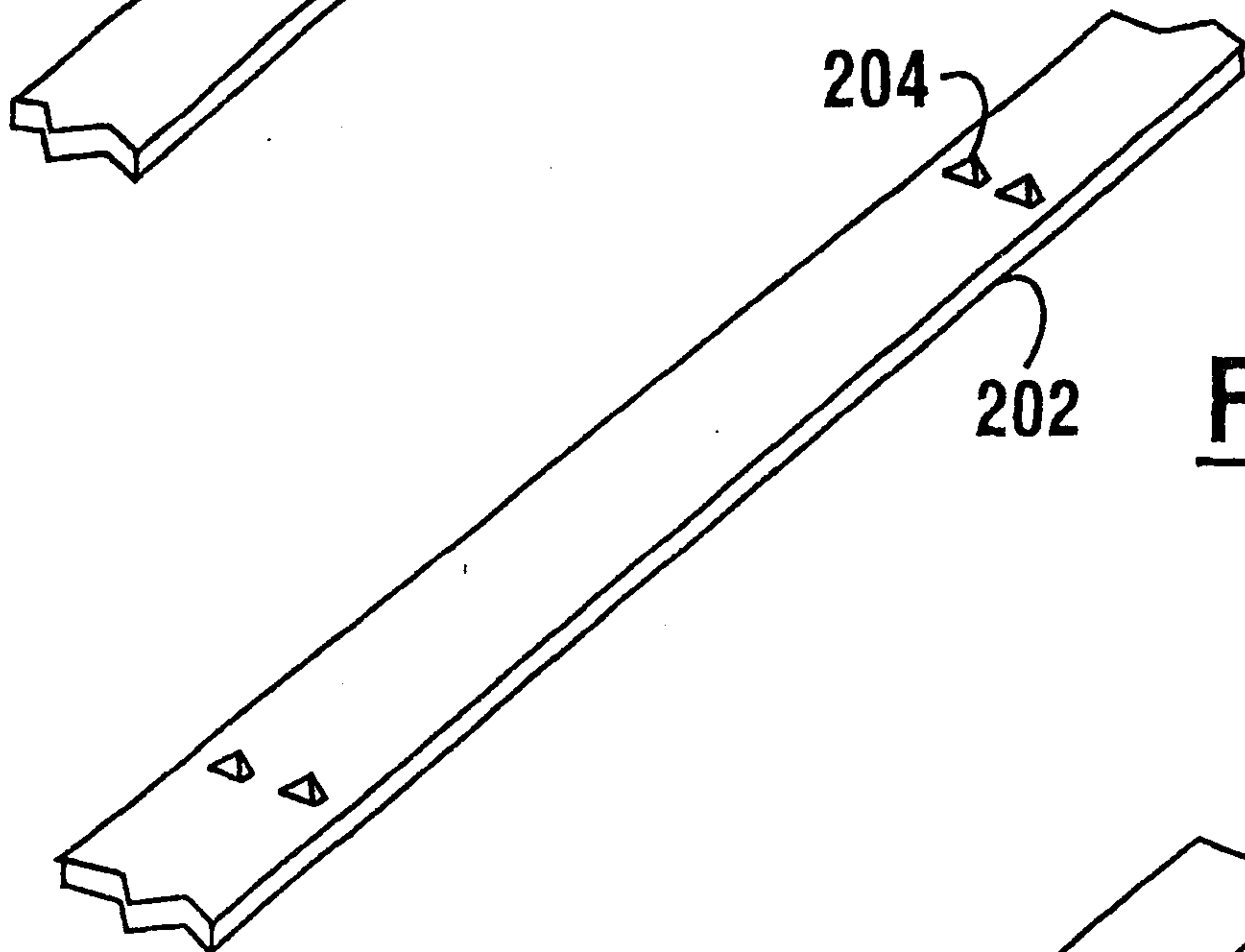
**FIG. 13**



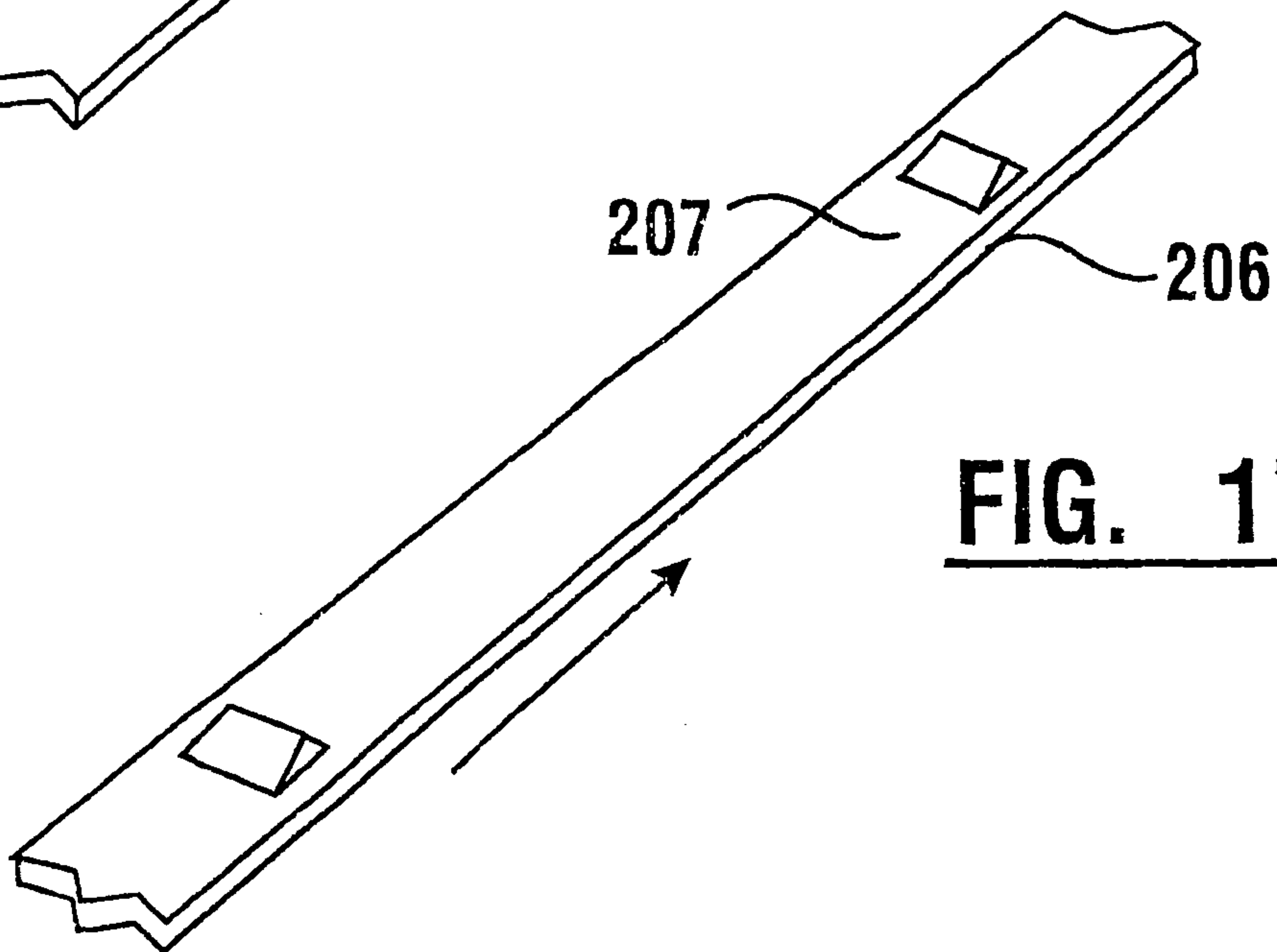
**FIG. 14**



**FIG. 15**



**FIG. 16**



**FIG. 17**

