

Oct. 4, 1949.

I. NETTLES

2,483,837

GUN WITH RECIPROCATABLE BREECH BLOCK AND ROTARY FEEDER

Filed Oct. 15, 1945

3 Sheets-Sheet 1

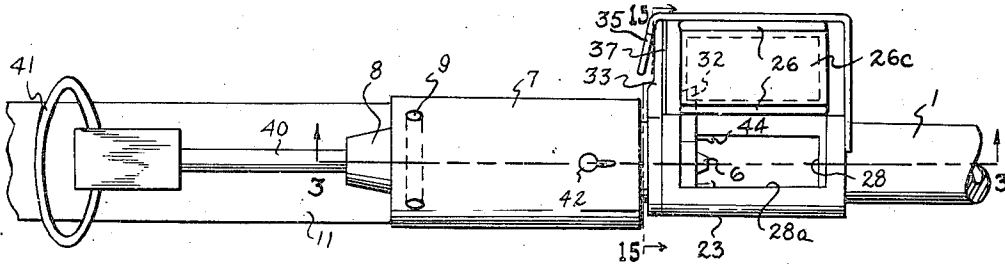

Fig. 1

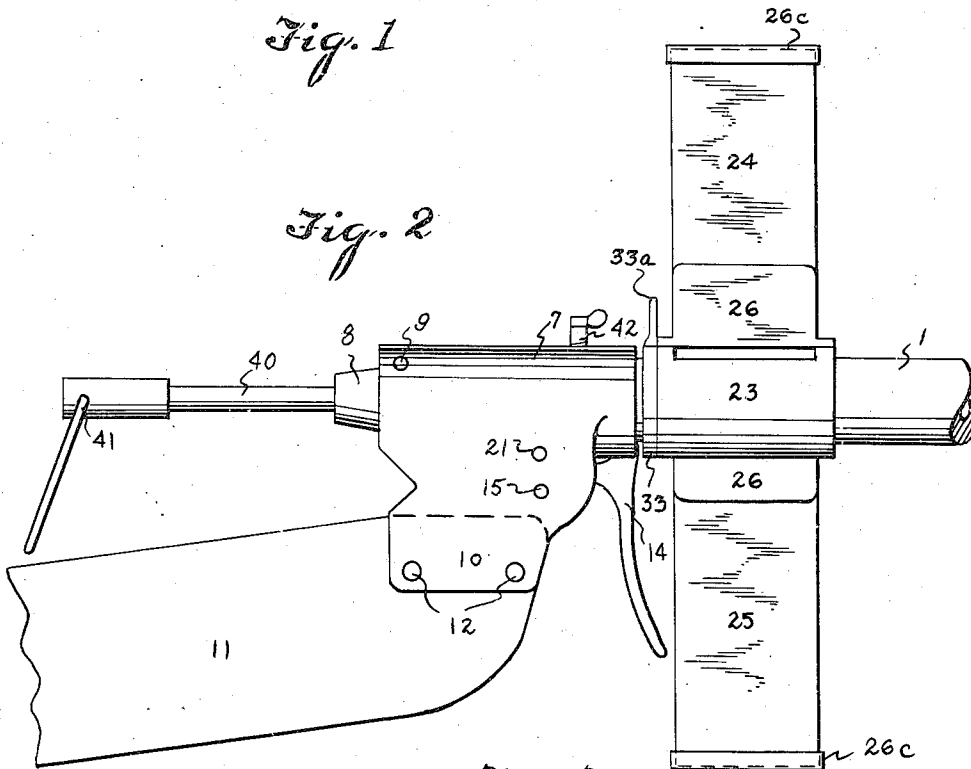

Fig. 2

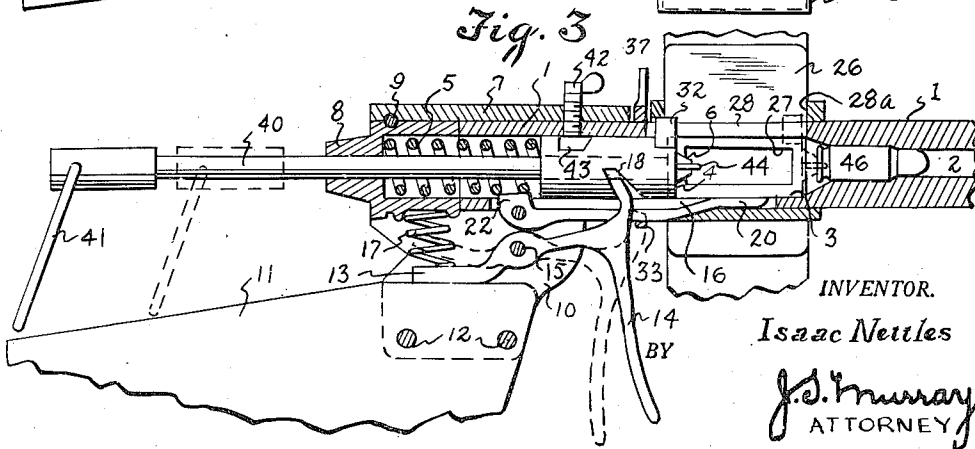

Fig. 3

INVENTOR.

Isaac Nettles

J. S. Murray
ATTORNEY

Oct. 4, 1949.

I. NETTLES

2,483,837

GUN WITH RECIPROCABLE BREECH BLOCK AND ROTARY FEEDER

Filed Oct. 15, 1945

3 Sheets-Sheet 2

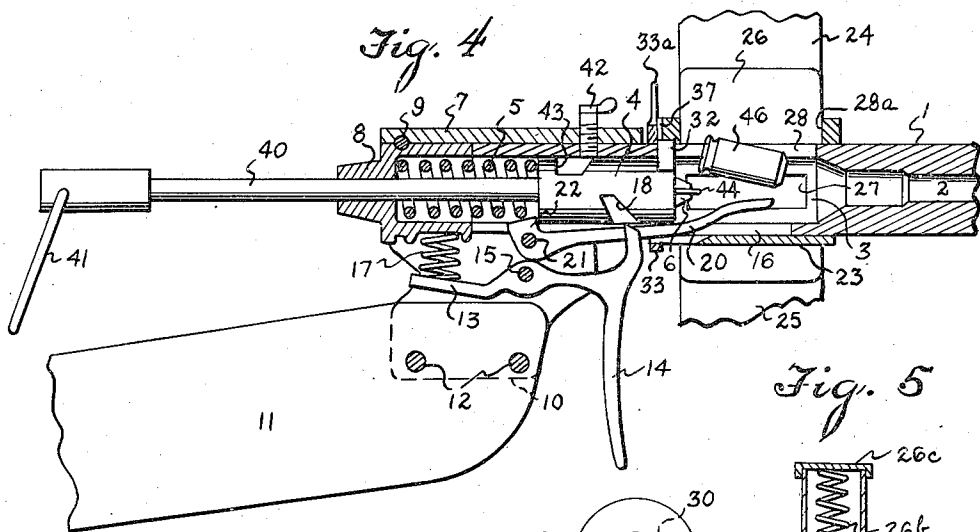

Fig. 5

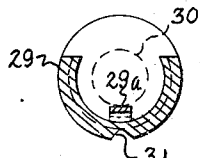
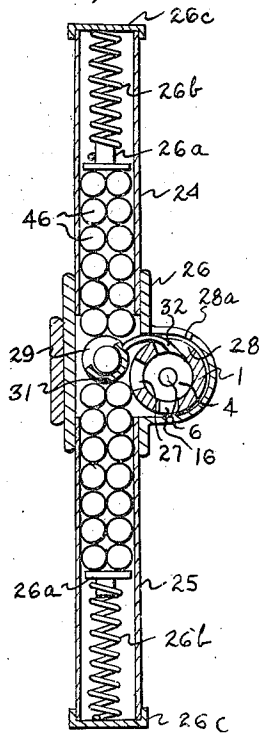

Fig. 10

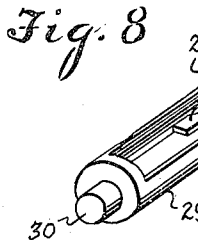

Fig. 8

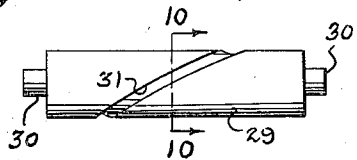

Fig. 9

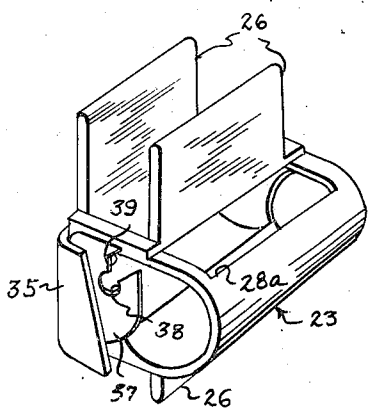

Fig. 6

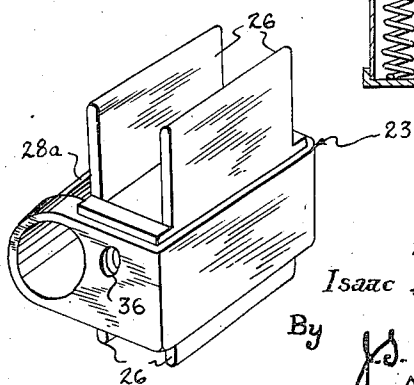

Fig. 7

INVENTOR.
Isaac Nettles

By J. S. Murray
ATTORNEY

Oct. 4, 1949.

I. NETTLES

2,483,837

GUN WITH RECIPROCABLE BREECH BLOCK AND ROTARY FEEDER

Filed Oct. 15, 1945

3 Sheets-Sheet 3

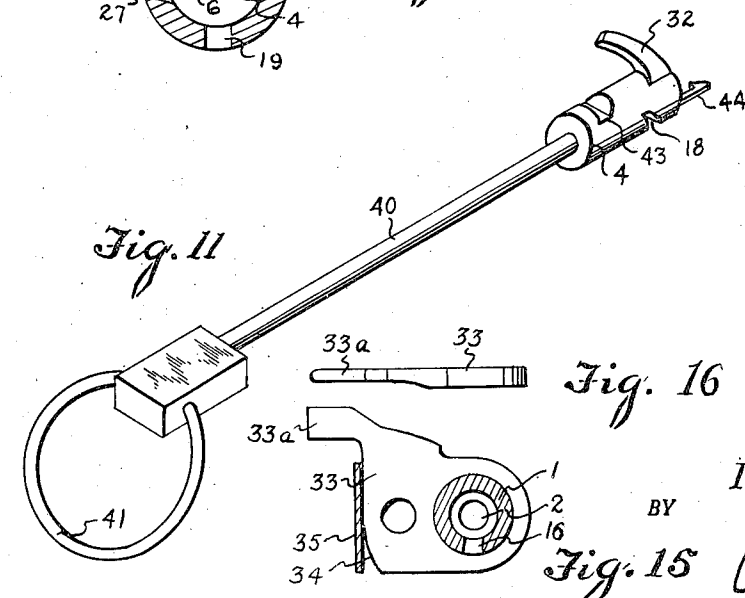
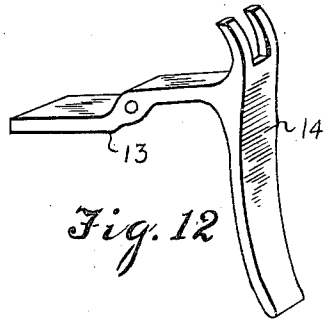
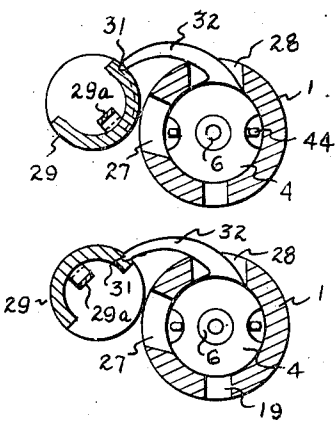
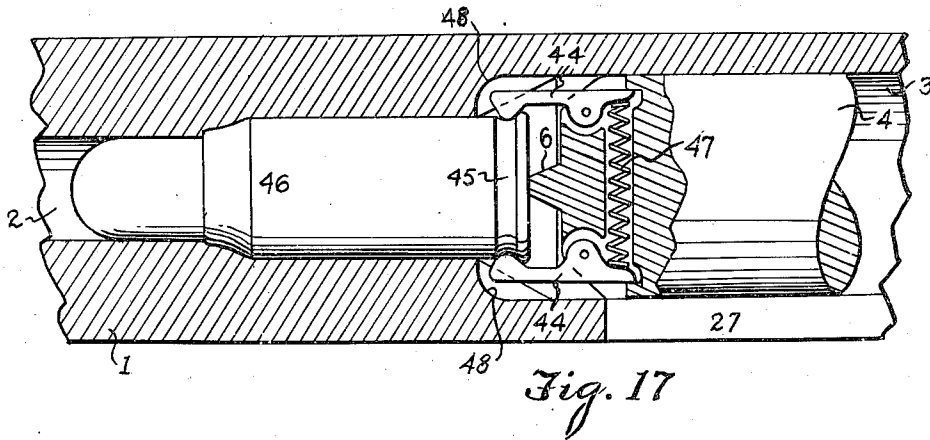

INVENTOR.
Isaac Nettles
BY
J. S. Murray
ATTORNEY

UNITED STATES PATENT OFFICE

2,483,837

GUN WITH RECIPROCABLE BREECH BLOCK AND ROTARY FEEDER

Isaac Nettles, Detroit, Mich.

Application October 15, 1945, Serial No. 622,355

4 Claims. (Cl. 42—18)

1

This invention relates to automatic firearms and particularly such firearms having magazine feeds.

An object of the invention is to simplify automatic firearms as heretofore designed and minimize their mechanism and cost.

Another object is to provide a simple, novel, and highly reliable automatic mechanism for feeding cartridges from a magazine to the loading chamber of a firearm.

Another object is to provide a firearm with dual magazines extending respectively upwardly and downwardly from the loading chamber and to utilize a single automatic feed mechanism for delivering cartridges from both magazines to said chamber.

Another object is to eject spent cartridge cases from an automatic firearm by an improved automatic device.

A further object is to adapt the loading and firing mechanism of a firearm to be very readily assembled or disassembled.

These and various other objects are attained by the construction hereinafter described and illustrated in the accompanying drawings, wherein:

Fig. 1 is a top plan view of the feed and firing mechanism of my improved gun.

Fig. 2 is a side elevational view of the same, showing the trigger cocked.

Fig. 3 is an axial vertical sectional view of the same, taken on the line 3—3 of Fig. 1, the firing position of the breech block being shown in dash lines.

Fig. 4 is a view similar to Fig. 3 but showing ejection of a spent cartridge case.

Fig. 5 is a cross sectional view of the gun, particularly showing the magazines.

Figs. 6 and 7 are perspective views of the magazine and feeder support.

Fig. 8 is a perspective view of the cartridge feeder.

Fig. 9 is a bottom view of the feeder.

Fig. 10 is a cross sectional view of the feeder, taken on the line 10—10 of Fig. 8.

Fig. 11 is a perspective view of the breech block and its stem and handle.

Fig. 12 is a perspective view of the trigger.

Fig. 13 is a diagrammatic cross sectional view of the loading chamber showing establishment

2

by the breech block of the limiting loading position of the rotary feeder.

Fig. 14 is a similar view, showing the discharge position of the rotary feeder.

Fig. 15 is a cross section taken on the line 15—15 of Fig. 1, showing a rotary wedging plate which secures the magazine and feeder support rigidly on the gun barrel extension.

Fig. 16 is a top plan view of said wedging plate.

Fig. 17 is a horizontal axial sectional view of the breech block in firing position, showing cartridge clutching means on said block.

In these views, the reference character 1 designates a gun barrel having a rearward extension 1a and having its bore 2 opening forwardly from a cylindrical loading chamber 3 in such extension. Such chamber is coaxial with the bore and materially exceeds the latter in diameter. Reciprocatory in the chamber 3 is a breech block 4, forwardly urged by a coiled spring 5, and having the usual striker 6 centrally projecting from its front end. A tubular receiver 7 of lesser longitudinal extent than the loading chamber snugly embraces the barrel extension, being welded or otherwise rigidly secured to such extension. Said receiver extends sufficiently rearward of the barrel extension to receive a plug 8 which abuts said extension, is rigidly retained in the receiver, as by a cross pin 9, and forms a rear abutment for the spring 5. The receiver 7 has a pair of downwardly projecting lugs 10, between which a suitable portion of a stock or handle 11 is rigidly held by rivets 12 or the like.

The stock 11 is slightly spaced downwardly from the receiver 7 to accommodate between the lugs 10 an arm 13 rigidly carried by and rearwardly projecting from a trigger 14 pivoted on a pin 15 mounted in said lugs and engaging said arm. The trigger has a bifurcated detent portion (see Fig. 12) projecting above the arm 13, and received freely in a slot 16 formed jointly in the barrel extension and receiver 7. A coiled spring 17 compressed between the plug 8 and rear end of the arm 13 urges the trigger upwardly and tends to snap said detent portion into a notch 18 of the breech block when the latter is retracted, as in Fig. 3.

Disposed between the furcations of the trigger detent and within a longitudinal slot 19 downwardly opening in the barrel extension 1a and

3

receiver 7, is an ejector arm 20 having its rear end pivoted on a pin 21 transversely mounted in said receiver. The rear end of this arm is formed with a lug 22 projecting slightly into the chamber 3 and forming a stop limiting retraction of the breech block. Impact of the breech block against this stop serves to swing the ejector arm upwardly through a small angle (Fig. 4) to impart a sharp blow to a spent cartridge case for ejecting the latter as hereinafter more fully explained.

Forwardly of the receiver 7, the barrel extension extends through and rigidly carries a support 23 for cartridge magazines 24 and 25. These extend respectively upwardly and downwardly from said support at one side of the barrel extension. They are secured to the support by a pair of lugs 26 upstanding on the support at opposite sides of the upper magazine and preferably welded to the latter. The cartridges in the magazines are urged toward the loading chamber by followers 26a under pressure of springs 26b compressed between said followers and coverplates 26c. The barrel extension has a lateral slot 27 facing toward the magazines for admitting loaded cartridges to the loading chamber, and registering upwardly opening slots 28 and 29a are formed respectively in said extension and support for ejection of spent cartridge cases.

Between the two magazines and in lateral proximity to the cartridge feed slot 27, an elongated rotary cartridge feeder 29 is mounted in the support 23 with its axis of rotation parallel to the barrel. Said feeder is trough shaped and proportioned to receive a single cartridge and is formed with a pair of trunnions 30 at its ends for journaling it in the end walls of the support 23. A light leaf spring 29a is preferably secured to the feeder within its trough to facilitate discharge of cartridges from the feeder. This spring is compressed by insertion of any cartridge in the feeder 29, due to follower spring pressure, and as the open half of the feeder is brought into communication with the slot 27 (Fig. 14), the spring 29a materially adds to the gravitational tendency of the cartridge to escape from the feeder and enter the loading chamber. The bottom face of the feeder is substantially semi-cylindrical and spirally grooved from end to end as indicated at 31, and a small cam finger 32 fixed on the front end of the breech block, within the slot 28, projects toward the feeder and terminally engages in the spiral groove 31. This has the effect of rocking the feeder through substantially one half turn in one direction as the breech block is advanced to its firing position and in the opposite direction, on retraction of said block, the two limiting positions of the feeder being shown in Figs. 13 and 14.

The rear wall 33 of the support 23 is formed as a separate plate and a rotation of such plate on the barrel extension is utilized to wedge the plate and support into a firm interengagement such as to maintain their proper positions relatively and also with respect to the extension 1a (Figs. 15 and 16). Thus, the plate 33 has an edge 34 remote from the barrel extension partially curved to adapt the plate, by a downward rocking on said extension to be wedged into engagement with a keeper 35, integrally formed on the rear end of the support and projecting toward the barrel extension in a slightly spaced relation to the rear face of the support. This wedging engagement stresses the support and plate both tightly against

4

said extension, the former under tension and the latter under compression, thus firmly holding them against any movement relative to said extension. Another function derived from the plate 33 is that of supporting the front end of the ejector arm 20, so that the latter may not drop below its proper position of use. Preferably said plate has an outwardly projecting lug 33a which may be struck to loosen said plate.

The front trunnion of the rotary feeder 29 is journaled in an opening 36 in the front wall of the support 23, and a plate 37, adapted to be set into and against the rear end of said support, is formed with an opening 38 to receive the rear trunnion of the feeder. Said plate is held firmly in position by the plate 33 when the latter is wedged into its assembly position. A slot 39 extends from the opening 38 to the margin of the plate 37 as a passage for the cam arm 32.

Ordinary retraction of the breech block will be automatically accomplished by blowback pressure, but it will occasionally be necessary to effect such retraction manually, as when a cartridge proves defective or during cleaning of the gun. To conveniently provide for manual retraction, a stem 40 rigidly connected to the breech block extends rearwardly therefrom and slidably through the plug 8, said stem having a suitable handle on its rear end such as the ring 41. It is desirable to provide a safety device to hold the breech block positively retracted, independently of the trigger, when desired. This purpose is served by a screw 42 set into the receiver 7 and movable inwardly by a few turns to enter a notch 43 in the breech block in a retracted position of the latter.

To facilitate removal from firing position of defective cartridges or of any cartridge that has not been fired, it is desirable to mount a cartridge clutch or gripper on the breech block. For this purpose, a pair of small laterally spaced gripping fingers 44 are pivoted on the front end of the breech block (Fig. 17), their forward ends being slightly hooked to engage in the annular groove 45 adjoining the rear end of a cartridge 46. Rearwardly of their pivots, said fingers are urged apart by a coiled spring 47 compressed within a diametrical bore of the breech block. As the striker of the breech block impacts the fulminating cap, the fingers 44 snap into the groove 45, so that any ensuing retraction of the block entails a retraction of the cartridge, whether such retraction is responsive to recoil or manually effected. The barrel is formed with two small pockets 48 opening forwardly from the chamber 3 to accommodate the front ends of the fingers 44 in the projected position of the breech block.

In use of the described gun, assume that the safety screw 42 is retracted to clear the breech block and that the latter is held retracted, as per Fig. 3, through engagement of the trigger detent in the notch 18. When the trigger is pulled, the breech block is released and projected by its spring 5 whereby a cartridge in firing position is discharged. In the course of its projection, the breech block acts through its cam finger 32 to rock the feeder 29 from its unloading position confronting the slot 27 (Fig. 14) to its loading position (Fig. 13), in which the feeder trough opens upwardly. As the bullet discharges from the fired cartridge, blowback pressure throws the cartridge case into the loading chamber 3, the breech block retracting under the pressure thus applied. In the course of its retraction, the breech

5

block acts through its cam finger 32 to rock the feeder 29 to its unloading position in which a cartridge from one of the magazines discharges into the loading chamber. The retractive stroke of the breech block is limited by its encountering the lug 22, and the resultant impact swings up the ejector arm 20 (Fig. 4) contacting the front portion of said arm sharply with the spent cartridge case. The latter is thus thrown from the chamber 3 through the slots 28 and 28a. Assuming the trigger to be maintained in firing position, the breech block is now again projected by its spring 5, and acts through the cam finger to return the rotary feeder to loading position and at the same time forces the cartridge which has just been delivered to the loading chamber into firing position, finally firing such cartridge. An automatic repetition of the described cycle continues until the contents of both magazines are exhausted, provided the trigger is held long enough in firing position. However, release of the trigger will discontinue the action, whenever desired, so that a single bullet or any desired number of successive bullets may be discharged, within the capacity of the two magazines.

By providing two magazines, as described and shown, a greater firing capacity is obtainable that may be had from a single magazine unless the latter is unduly large and undesirably elongated. A given capacity distributed between two magazines permits of a more effective use of spring-pressed followers than would be true of a single magazine equal in capacity to the two. Also the gun is maintained in much better balance by employing upper and lower magazines than would be true of a single one. While the feeder is positioned to receive a cartridge from the lower magazine only in the course of its rocking travel, this serves the purpose. An initial operation of the rotary feeder, subsequent to filling of both magazines, will deliver a cartridge from the upper magazine to the loading chamber. Thereafter the feeder will successively receive cartridges from the lower magazine until the latter is emptied. The cartridges in the upper magazine will be successively received and delivered by the feeder in subsequent operations of the latter. When lower magazine is empty, the rotary feeder remains empty during each return travel to its loading position (Fig. 13), and upon assuming such position it will immediately receive a cartridge from the upper magazine. After emptying of the lower magazine, its follower 26a so adjoins the feeder as to prevent escape of cartridges into the lower magazine.

Location of the magazines at one side of the barrel extension is vital in preventing interference with sighting the gun on a target, and also avoids interference with manipulation of the trigger.

By virtue of its highly simplified cartridge feed and cartridge case ejector mechanisms, the described gun is less expensive and less likely to give trouble than present day automatic firearms.

What I claim is:

1. A gun having a loading chamber, a bore opening forwardly from said chamber, a car-

6

tridge inlet to said chamber, and an outlet from said chamber for spent cartridges, said gun comprising a breech block reciprocatory forward and back in said chamber, a rotary cartridge feeder in delivery proximity to said inlet and formed with a substantially spiral camway, and a cam arm on the breech block projecting through said outlet and terminally engaging in the camway of the feeder to rock the feeder responsive to reciprocation of the breech block.

2. A gun having a loading chamber, a bore opening forwardly from such chamber, and a cartridge inlet to such chamber, said gun comprising a breech block reciprocatory forward and back in the loading chamber, a rotary feeder in delivery proximity to said inlet and formed with an approximately spiral groove, and a cam finger on the breech block permanently engaged in said groove to rock the feeder responsive to breech block reciprocation.

3. In a gun as set forth in claim 2, a barrel having an extension wherein said loading chamber is formed, such extension having a slot through which said cam finger projects to engage the rotary feeder, said cam finger restraining the breech block from material rotation through engagement in said slot.

4. A gun having a loading chamber with a cartridge inlet laterally opening from said chamber and an outlet for spent cartridges upwardly opening from said chamber, said gun comprising a breech block reciprocable forward and back in said chamber, a rotary cartridge feeder in delivery proximity to said inlet and formed with a substantially spiral camway, and a cam arm on the breech block extending upwardly through said outlet and thereby resisting material rotation of the breech block, and extending laterally from said outlet and terminally engaged in said camway, whereby the feeder is rocked responsive to reciprocation of the breech block.

ISAAC NETTLES.

REFERENCES CITED

The following references are of record in the file of this patent:

UNITED STATES PATENTS

Number	Name	Date
73,351	Lord	Jan. 14, 1868
594,853	Burton	Dec. 7, 1897
723,232	Bergmann	Mar. 24, 1903
1,297,859	Johnson	Mar. 18, 1919
1,349,350	Tunks	Aug. 10, 1920
1,413,694	Vollmer	Apr. 25, 1922
1,485,460	Johnston	Mar. 4, 1924
1,674,370	Methlin	June 19, 1928
1,709,399	Herlach et al.	Apr. 16, 1929
1,851,696	Ekdahl	Mar. 29, 1932
2,049,776	Hyde	Aug. 4, 1936
2,081,235	Hillyard	May 25, 1937
2,231,978	Wesson	Feb. 18, 1941
2,274,195	Garrison	Feb. 24, 1942

FOREIGN PATENTS

Number	Country	Date
575,074	Germany	Apr. 24, 1933