



(19)

Europäisches Patentamt
European Patent Office
Office européen des brevets



(11)

EP 1 516 993 B1

(12)

EUROPEAN PATENT SPECIFICATION

(45) Date of publication and mention
of the grant of the patent:
14.06.2006 Bulletin 2006/24

(51) Int Cl.:
E06B 3/54 (2006.01)

(21) Application number: **04019380.7**

(22) Date of filing: **16.08.2004**

(54) **Structural facade having punctually suspended panes and window or wall frame system for said structural facade**

Fassade mit punktuell festgelegte Platten und Fenster- oder Türsystem für eine derartige Fassade

Facade avec panneaux ponctuellement suspendus et système de fenêtre ou porte pour une telle facade

(84) Designated Contracting States:
**AT BE BG CH CY CZ DE DK EE ES FI FR GB GR
HU IE IT LI LU MC NL PL PT RO SE SI SK TR**
Designated Extension States:
HR

(30) Priority: **18.09.2003 IT TO20030714**

(43) Date of publication of application:
23.03.2005 Bulletin 2005/12

(73) Proprietor: **Stramandinoli S.r.l.
10040 Rivalta di Torino (Torino) (IT)**

(72) Inventor: **Stramandinoli, Giovanni
10040 Rivalta di Torino
(Torino) (IT)**

(74) Representative: **Gallarotti, Franco
Buzzi, Notaro & Antonielli d'Oulx Srl,
Via Maria Vittoria, 18
10123 Torino (IT)**

(56) References cited:
**EP-A- 0 608 063 EP-A- 1 083 289
WO-A-03/031741 WO-A-03/062579
US-A- 6 105 319**

EP 1 516 993 B1

Note: Within nine months from the publication of the mention of the grant of the European patent, any person may give notice to the European Patent Office of opposition to the European patent granted. Notice of opposition shall be filed in a written reasoned statement. It shall not be deemed to have been filed until the opposition fee has been paid. (Art. 99(1) European Patent Convention).

Description

[0001] The present invention relates to the field of continuous structural façades, also known by the English term of "curtain walls", and in particular of the type with punctually suspended panes.

[0002] Façades of the type indicated above are formed by a plurality of mutually adjacent panes, arranged to form a substantially continuous surface of a building. In most cases, the panes are entirely made of glass, to form total see-through suspended façades.

[0003] Façades or glass walls of the type indicated above usually comprise a metal frame, positioned towards the interior of the building, whereto brackets are associated for supporting the panes; the latter, having for example a quadrangular shape, are provided with through holes, usually formed in correspondence with the respective corner or peripheral areas. Said holes are used to fasten particular connecting elements, substantially in the form of flathead bolts, connected in fixed fashion to the aforesaid brackets, which unload stresses on the aforesaid frame. The various panes supported by the frames are appropriately mutually sealed along the contiguous edges, for example by means of appropriate adhesive materials, such as special silicones.

[0004] Examples of embodiments of structural glass walls, with the related frames, brackets and connecting elements are described, for example, in EP-A-1 083 289 and EP-A-0 847 475.

[0005] In the façades or glass walls of the type indicated above the various panes, supported in the manner described above, are fastened in such a way as to maintain a stable position of lay. The only movements of the panes are those due to any minimal deformations of the support structure, caused for example by heat stresses, or by external stresses (wind, earthquakes, etcetera). For this reason, the sealing material is usually elastic, in order to allow, in addition to the necessary characteristics of air and water tightness, also a minimal possibility of relative movement between the panes, to offset the aforesaid deformations.

[0006] According to the current state of the art, the provision of openings, such as windows, presupposes the use of particular frames or dedicated section bars, which must be fastened within the curtain wall; in practice, therefore, in the point where a window is to be placed, one of the aforesaid frames is mounted instead of a pane, whereto the window is articulated or hinged.

[0007] In addition to complicating construction, this solution compromises the aesthetic homogeneity of the façade, because the aforesaid frames for the windows remain at least partially in view. Said drawback is further enhanced in the case of totally see-through suspended façades.

[0008] In light of the above, an object of the present invention is to provide a structural façade (or curtain wall), of the type set out above, provided with a window or door frame system of a new design and advantageous appli-

cation, especially from the viewpoint of simplicity and mounting economy.

[0009] Another object of the invention is to indicate such a curtain wall in which the presence of windows is very "discreet", in order to safeguard the stylistic homogeneity of the curtain wall itself.

[0010] These and other aims are attained, according to the present invention, by a curtain wall and by a window or door frame for curtain walls having the characteristics specified in the appended claims, which are to be considered as an integral part of the present description.

[0011] The invention shall now be described with reference to the accompanying drawings, provided purely by way of non limiting example, in which:

- Figure 1 is a schematic front view of a portion of a structural glass wall according to the invention;
- Figure 2 is an enlarged portion of Figure 1;
- Figure 3 is an enlarged and partially sectioned detail of Figure 1;
- Figure 4 is a schematic section view according to the line IV - IV of Figure 2;
- Figure 5 is a partial schematic section view according to the line V - V of Figure 4;
- Figure 6 is a partial schematic section view according to the line VI - VI of Figure 4;
- Figure 7 is a partial schematic section view according to the line VII - VII of Figure 2;
- Figure 8 is a first schematic lateral view of the structural glass wall of Figure 1, in a first condition of use;
- Figure 9 is a second schematic lateral view of the structural glass wall of Figure 1, in a second condition of use;
- Figure 10 is an enlarged detail of Figure 8;
- Figure 11 is an enlarged detail of Figure 9.

[0012] In Figures 1 and 2, reference number 1 globally designates a portion of a continuous curtain wall according to the invention. In the exemplified case, the curtain wall 1 comprises a plurality of punctually suspended clear glass panes 2, so that in the remainder of the description the curtain wall shall also be indicated with the term "glass wall".

[0013] As in the prior art, the glass wall 1 comprises a support frame, positioned towards the interior of the building, constituted by a series of cross members and uprights, some of which are designated as 3. As shown for example in Figure 4, brackets or supports 4, also known in itself, are fastened in a known manner to said uprights 3; in the exemplified case, and as visible in Figures 4, 5 and 7, the brackets 4 comprise a central portion 4A, for anchoring to a respective upright 2, wherefrom four inclined arms 4B radially depart, at whose free end a sort of eyelet 4C is defined.

[0014] The panes 2, which are here rectangular-shaped, have, at each angle area, a respective through hole, for fastening respective connecting elements 5; in the exemplified case, and as visible for example in Fig-

ures 4, 5 and 7, the connecting elements 5 are substantially in the form of flathead bolts, constructed substantially according to the prior art (see the previously mentioned prior documents); on one hand, the connecting elements 5 are fastened in correspondence with the aforesaid through holes of the panes 2 and, on the other side, they are fastened each in a related eyelet 4C of a respective bracket 4, in known manners.

[0015] The contiguous edges of the various panes 2 are sealed to each other by suitable means, such a silicone material designated as 6 in Figures 1, 2 and 3, which guarantees the necessary tightness against air and water/humidity and which has a certain degree of elasticity.

[0016] Also in Figure 1, the reference 2' designates a glass pane that is substantially similar to the ones already designated as 2, but provided with only three through holes, and in particular two upper holes, each formed in correspondence with a respective angle area of the pane 2', and a lower hole, formed in the intermediate area of the lower part of the pane 2'. As shall become readily apparent below, the upper holes are provided for fastening respective connective element 5', which are connected in articulated fashion to the respective bracket 4, whilst the lower hole is provide for fastening a respective connecting element 5" associated to an actuation element.

[0017] Along the edge of the pane 2' operates, instead of the sealing material 6, a peripheral gasket 7 which, as shall become readily apparent below, is capable of assuming two different operative conditions. Again in Figures 1-6, the number 10 globally designates an actuation and control unit for producing an angular actuation of the pane 2', so the latter can serve as a window or the like, able to be opened and closed as needed.

[0018] As shown in Figures 3 and 4, the unit 10 comprises a case 11, provided with flanges 12 for its anchoring between two brackets 4, which occurs in manners and with means that are known in themselves. Inside the case 2 two batteries are mounted, designated as 13, a compressed air generator or compressor designated as 14, an actuator 15 and a control system 16, including a receiver 17 of radio-frequency or infrared signals, which is a part of a remote control system.

[0019] In the exemplified case, the batteries 13 are of a known rechargeable type, for example 12 V, and provided to supply power to the compressor 14, the actuator 15 and the unit 16. The compressor 14, small sized and with an optional air tank, is also of a known design, for example of the type with reversible pump, similar to those which can be powered by means of a cigarette lighter power outlet on motor vehicles, for inflating and deflating rubber boats and the like. The actuator 15, in the exemplified case, is a linear electrical actuator of the chain type, i.e. the type in which an electric motor is able to determine the movement of a chain in two different directions, towards the exterior and the interior of the body of the actuator itself. The control system 16 is obtained in manners that are known to those skilled in the art, to perform the functions described below.

[0020] Outside the case 11, in its upper part, one or more photo-voltaic cells are mounted, designated as 18; said cells 18 are connected to the control unit 16, which complements a provision for recharging the battery 13, also known in itself. Preferably, the upper part of the body 11 is inclined (see for example Figure 6), in such a way that the cells 18 are oriented towards the pane 2', to be able to receive sunlight.

[0021] In the exemplified embodiment, the gasket 7 co-operating with the glass pane 2' is internally hollow and it is made of elastomeric material, or otherwise of elastic or flexible material, preferably transparent; the inner cavity of the gasket 7, designated as 7A in Figures 5-7, is connected, by means of at least one tube designated as 19 in Figure 4, to the compressor 14; in this way, in a first operating mode, the compressor 14 is able to generate a flow of air which is injected into the cavity 7A, until achieving the "inflation" of the gasket 7, to maintain then said condition at the end of its activation; in a second operating mode, the compressor 14 allows instead the aspiration or otherwise the exit of the air contained inside the cavity 7A of the gasket 7.

[0022] As shown in Figures 5-7, the edges of the pane 2' can be shaped to define a sort of throat, for example V-shaped, for housing a respective portion for fastening the gasket 7, in such a way that the diametrically opposite portion of the gasket is suitable to operate in sealed fashion on the edge of the contiguous pane 2, when the gasket 7 is in the respective inflated condition. Between the surfaces of the aforesaid throat and fastening portion of the gasket 7, a glue may be provided.

[0023] The edges of the panes 2 could also be provided with a similar throat or seat, able to receive a respective sealing portion of the gasket 7, when the latter is in the respective inflated condition.

[0024] Figure 6 shows a schematic section of the unit 10, within which the actuator 15 is housed (note that, for the sake of greater clarity, in this figure the representation of a bracket 4 has been omitted); as can be noted, from the body of the actuator 15 an actuating element 15A partially projects, through a respective passage, which here is assumed to be a metal chain.

[0025] The free end of the chain 15A is operatively coupled, preferably by means of an articulation S1, to a connecting element 5", substantially similar to the elements 5, which is fastened in correspondence with the aforesaid through hole present in the central area of the lower part of the pane 2'. In a possible embodiment, the element 5" could be glued to the surface of the pane 2' oriented towards the interior of the building, and hence without the need for the aforesaid lower through hole.

[0026] Figure 5 shows one of the brackets 4 which are at the angle areas of the lower part of the pane 2'. As stated, the pane 2' does not have through holes in the lower corner areas; in this case, instead of a connecting element 5, a simple support element 20 is fastened to the bracket, preferably having a head made of synthetic and elastic material 20A, whereon the surface of the pane

2' which is oriented towards the interior of the façade 1 or of the building can be set down.

[0027] Figure 7 instead shows one of the brackets 4 which are located at the corner areas of the upper part of the pane 2'. As it is readily apparent, in this case connecting elements 5' are provided, fastened in the upper through holes of the pane 2', which are substantially similar to the element 5 but are coupled in articulated fashion to the respective bracket 4, for example through an articulated joint, shown only schematically and designated as S2, achievable in any manner known in the art.

[0028] In Figures 8, 10 and 9, 11 the pane 2' is shown in two possible operative conditions, respectively closed and open.

[0029] In the closed condition, as shown in Figures 8 and 10, the pane 2' is substantially flush with the other panes 2 which compose the wall 1. In this condition the gasket 7 is full of air, i.e. inflated, in order to exert its sealing action between the edges of the pane 2' and the edges of the panes 2 contiguous thereto. In this situation, the action of the gasket 7 also contributes to maintain the pane 2' in the respective closed position, i.e., aligned relative to the panes 2. This position is also maintained by virtue of the presence of the chain 15A, which is connected by means of the respective connecting element 5" to the pane 2'; note on this point that, in the condition with the actuator 15 not powered, the chain 15A is locked in position, holding the surface of the pane 2' in contact with the heads 20A of the supports 20, as shown in Figure 8, thereby preventing the pane from moving.

[0030] When the opening of the pane 2' is desired to be controlled, i.e. the pane 2' is to be brought to the position shown in Figures 9-10, the user operates a remote control, not shown, pressing an opening push-button. The signal emitted by the remote control is received by the respective receiver 17 integrated in the control system 16, which consequently determines at first the deflation of the gasket. Depending on the chosen implementation, the deflation can be active, in the sense that the compressor 14 will operate in suction, removing the air present in the chamber 7A inside the gasket 7. Alternatively, the compressor 14 can simply operate to place the chamber 7A in communication with the outside environment, in order to allow the easy deformation of the gasket 7 during the opening movement of the pane 2'.

[0031] After a predefined time, deemed sufficient to eliminate air pressure inside the gasket 7, the system 16 powers the actuator 15, in a first direction of operation. The electric motor inside the actuator 15 thus causes the chain 15A to project outside the case of the actuator itself, and hence determines a thrust on the connecting element 5".

[0032] In this way, since it is not constrained inferiorly to the brackets 4, but only set down on the heads 20A of the elements 20, the pane 2' is moved angularly towards the exterior of the curtain wall 1, by virtue of the presence of the articulated support to the upper brackets 4, constituted by the connecting elements 5' and by the respec-

tive joints S2.

[0033] Upon reaching the desired degree of opening for the pane 2', the pressure of a stop push-button present on the remote control determines the interruption of the supply of power to the actuator 15, with the consequent arrest of the motion of the pane, in the operative condition shown in Figures 9, 11. The actuator 15 will preferably comprise within it an end-of-stroke device, known in itself, such as a micro-switch, able to detect the reaching of the maximum possible degree of projection of the chain 15A outside the body of the actuator 15, in such a way as automatically to command it to stop.

[0034] When the pane 2' is to be brought back to the position as per Figures 8, 10, the user need do no more than operating a closure push-button on the remote control. This causes the actuator 15 to operate in the opposite direction with respect to the previous one, i.e. rewinding the chain 15A inside the body of the actuator itself, which causes an angular motion of the pane 2' that is opposite to the previous one. The pane 2' then returns to bear down on the head 20A of the elements 20 which, as stated, are preferably made of elastic or resilient material.

[0035] In this case, too, the reaching of the closed position can advantageously be detected or determined by end-of-stroke means, known in themselves, for example in the form of micro-switches, positioned inside the actuator 15 or provided for directly detecting the reaching, by the internal face of the pane 2', of a predefined closed position.

[0036] Once said closed position has been reached, the control system 16 controls the compressor 14, such that the latter admits compressed air to the cavity 7A of gasket 7; in this way, the gasket is thus inflated, in order to newly operate for sealing and locking the edges of the pane 2' with respect to the edges of the panes 2 contiguous thereto.

[0037] In the embodiment of the invention exemplified in the figures, the photo-voltaic cells 18 are oriented, as stated, towards the wall 1, in order to receive the light that passes through it and thereby generate electrical energy to recharge the batteries 13 that power the unit 10. Naturally, nothing prohibits the unit 10 from being powered directly by an electrical wire connected to the electrical system of the building, in which case the batteries 13 could still be provided as an auxiliary energy source in case of accidental interruptions in mains voltage.

[0038] From the above description, the characteristics and the advantages of the present invention are readily apparent. Among its advantages, in particular, it is noted that the system described herein is easy to mount, by virtue of the use of a limited number of simple and economical components. The proposed solution allows to construct structural continuous façades and glass walls with no need to provide special section bars for mounting windows and other frames, which disrupt the overall appearance of the glass wall or façade.

[0039] Clearly, numerous variants to the system de-

scribed as an example herein are possible for the person skilled in the art, without thereby departing from the scope of the inventive idea.

[0040] Instead of electrical components, the unit 10 could comprise different types of actuators. For example, the actuator 15 can be pneumatically operated, in which case a same compressed air generator can advantageously be used to achieve both the inflation of the gasket 7 and the physical actuation of the pane 2'. Equally, the actuator 15 could be hydraulic or oleodynamic, and the gasket 7 could also be operated hydraulically, i.e., assume the respective expanded condition when filled with a liquid, for instance an oil, with the passage to the open position achievable by evacuating said fluid from the interior of the cavity 7A.

[0041] Alternatively, or in combination with one of the above solutions, the unit 10 could comprise a manual actuation system, operative to generate both the force for actuating the pane 2' and the positive/negative pressure needed by the gasket 7.

[0042] In the case exemplified above, the pane 2' can perform angular movements around a horizontal axis, which extends substantially near the upper terminal area of the pane itself. However, it is clear that the axis of rotation could be near the lower end, or in an intermediate area of the pane. Obviously, the axis of rotation could also be positioned vertically, in which case the case 11 of the unit 10 shall also be positioned vertically, and also fastened between two brackets 4.

[0043] The shape of the case 11 may naturally be different from the one shown herein, for example with a cross section that is square, rectangular, circular, etcetera.

[0044] The gasket 7 could be associated to the edges of the panes 2 that surround the pane 2', instead of being mounted thereon. The system could also comprise a "passive" gasket, i.e., a more traditional one, and an "active" gasket according to the invention, for example in male-female form, one borne by the pane 2' and the other one borne by the pane 2.

[0045] Section bars for fastening the gasket or gaskets could be associated to the edges of the panes 2 or 2', preferably made of transparent material.

[0046] The gasket 7 could have a different section from the one shown by way of non limiting example, and also have a different type of operation, whilst maintaining its characteristic of being able to assume an "expanded" configuration and a "restricted" configuration, as a result of a command or activation imparted by a user.

[0047] In this view, for example, the gasket and/or a support or fastening means thereof could be at least in part made of an active shape memory material, such as an SMP (Shape Memory Polymer). As is well known, said polymers are able to modify their rigidity and shape according to the temperature whereto they are exposed and rapidly pass, if heated, from a rigid state to a highly deformable rubbery state, then returning equally rapidly, when heating ceases, to their original shape and hard-

ness. Thanks to their "memory", SMPs can return to their original shape an infinite number of times, if taken beyond their critical temperature again.

[0048] In the proposed variant, therefore, the gasket or a support thereof could at least in part be made of a shape memory polymer, suitably connected to electrical power supply means, to be heated by Joule effect above its transition temperature, the aforesaid power supply means being driven by the control system 16 of the unit 10. In the condition with the pane 2' closed, as shown in Figures 8, 10, the SMP gasket is not heated, in order to remain in the respective rigid state and it serves its sealing and locking function; if opening of the pane 2' is desired, to the position shown in Figures 9, 11, the SMP gasket is heated by Joule effect, in order to pass to the respective rubber and deformable state, thereby allowing the movement of the pane, obtained in the manners described above; once the opening is accomplished, the power supply to the SMP gasket can then be interrupted. Preferably, the SMP gasket will also be powered while the pane 2' is being closed, so that it can assume its respective rubbery and deformable state, and thus be able again to insinuate itself in contact with the edges of the panes 2 contiguous to the pane 2'; once the position visible in Figures 8, 10 is reached, electrical power supply will be interrupted, to allow the gasket to return to the respective rigid state and perform its sealing and locking function.

[0049] In the case of implementation with gasket 7 able to contain a fluid (air, gas, liquid, etcetera), the system for feeding the gasket could be provided with an operative sensor to monitor the pressure of the fluid inside the chamber 7A, in order to detect any pressure drops in the chamber and consequently activate the compressor 14 automatically, to assure a correct seal at all times.

Claims

1. Structural façade (1) comprising

- a plurality of panes or the like (2, 2'), in particular made of transparent material, locally suspended in side by side positions substantially according to a same plane of lay,
- a fixed structure (3) whereto support means (4, 5, 5', 5'') for the panes (2, 2') are associated, the support means (4, 5, 5', 5'') of each pane (2, 2') comprising a plurality of connecting devices (5),

where each connecting device (5, 5', 5'') is sustained, at one side, by means of the fixed structure (3) and is fastened, at the other side, in a localised area of the respective pane (2, 2'), and where each pane (2, 2') has at least an edge that is contiguous to the edge of another pane (2, 2'), between the contiguous edges sealing means (6, 7) being provided, **character-**

ised in that

- at least a first of said panes (2') is capable of moving (2') relative to said plane of lay,
 - said sealing means (6,7) comprise first sealing means (7) co-operating with said first pane (2') and able to be operated to pass from a respective operative condition to a respective inoperative condition, and vice versa,
 - first actuating means (14) are provided, able to be selectively operated to determine the passage of the first sealing means (7) between the respective operative and inoperative conditions.
2. Façade according to claim 1, **characterised in that**, in said operative condition, said first sealing means (7) are at least in part operative to hold said first pane (2') in said plane of lay.
 3. Façade according to claim 1, **characterised in that** second actuating means (15) are provided, able to be selectively operated to cause the displacement of said first pane (2') relative to said plane of lay, where in particular, in said operative condition of said first sealing means (7), said second actuator means (15) are operative to hold said first pane (2') in said plane of lay.
 4. Façade according to claim 1, **characterised in that** the connecting devices (5, 5") fastened to said first pane (2') comprise at least a first connecting device (5') supported in articulated fashion by said fixed structure (3).
 5. Façade according to claim 1, **characterised in that** the connecting devices (5, 5") fastened to said first pane (2') comprise at least a second connecting device (5") associated to a movable element (15A) actuated by said second actuating means (15).
 6. Façade according to claims 4 and 5, **characterised in that** the first connecting device (5') is fastened in a through hole being defined in an area of said first pane (2') that is opposite the one in which the second connecting device (5") is fastened.
 7. Façade according to claim 1, **characterised in that** said fixed structure (3) supports bearing means (20) whereon said first pane (2') is held directly or indirectly in contact when the pane itself in said plane of lay, said bearing means comprising in particular at least one element (20) having a head made of elastic material (20A), whereon a localised area of the surface of said first pane (2') can be set.
 8. Façade according to claim 1, **characterised in that** said first sealing means comprise a gasket (7), where in particular, in said inoperative condition, said gas-
- ket (7) has a greater degree of deformability than when the gasket is in said operative condition.
9. Façade according to claim 8, **characterised in that** said gasket (7) is made of elastic material and comprises an inner cavity (7A), said cavity being capable of containing a pressurised fluid when the gasket is in said operative condition.
 10. Façade according to claim 8, **characterised in that** said gasket (7) is at least in part made with a shape memory active material, such as a shape memory polymer, and/or has support means that are least in part constructed with a shape memory active material, such as a shape memory polymer.
 11. Façade according to claim 9, **characterised in that** said first actuating means comprise a compressed air generator (14), in particular connected to said cavity (7A) by means of a conduit (19).
 12. Façade according to claim 10, **characterised in that** said first actuating means comprise means operative to cause the heating of said active material.
 13. Façade according to claim 3, **characterised in that** said second means comprise an actuator (15), in particular of the chain type (15A).
 14. Façade according to claim 1 or 3, **characterised in that** at least one of said first actuating means (14) and second actuating means (15) is controlled by a control system (16).
 15. Façade according to claim 14, **characterised in that** said first actuating means (14), said second actuating means (15) and said control system (16) are comprised in a same unit (10), in particular sustained by said fixed structure (3).
 16. Façade according to claim 1 or 3, **characterised in that** electrical battery means (13) are provided, capable of supplying power to said first and/or second actuating means (14, 15).
 17. Façade according to claim 16, **characterised in that** said battery means are of the rechargeable type and **in that** one or more photo-voltaic cells (18) are operatively connected to said battery means (13), said cell or cells being part of an arrangement for recharging said battery means.
 18. Façade according to claim 14, **characterised in that** said control system (16) includes a receiver (17) of remote control signals, for controlling the operation of said first and/or second actuating means (14, 15).
 19. Façade according to claim 14, **characterised in that**

said control system (16) comprises end-of-stroke means, operative to detect or determine the reaching of a determined position by said first pane (2'), said end-of-stroke means comprising in particular at least one between:

- first end-of-stroke means, operative to detect or determine the reaching of a maximum degree of displacement of said first pane (2') with respect to said plane of lay,
- second end-of-stroke means, operative to detect or determine the reaching, by said first pane (2'), of a predefined closure position.

20. Façade according to at least one of the previous claims, **characterised in that** the edge of at least one between said first pane (2') and a second pane (2) contiguous thereto is shaped to define a throat or seat for housing a respective portion of said gasket (7).

21. Façade according to at least one of the previous claims, **characterised in that** said gasket (7) is mounted on at least one between said first pane (2') and a second pane (2) contiguous thereto.

22. Façade according to at least one of the previous claims, **characterised in that** said first actuator means and/or said second actuator means comprise actuators selected in the group consisting of electrical actuators, pneumatic actuators, hydraulic actuators, manual actuators.

23. Façade according to at least one of the previous claims, **characterised in that** said first pane (2') is mounted movable to effect angular motions around a substantially horizontal axis or around a substantially vertical axis.

24. Window or door system for a structural façade (1), comprising

- a plurality of panes or the like (2, 2'), in particular made of transparent material, locally suspended in side by side positions substantially according to a same plane of lay,
- a fixed structure (3) where to support means (4, 5, 5', 5'') for the panes (2, 2') are associated, the support means (4, 5, 5', 5'') of each pane (2, 2') comprising a plurality of connecting devices (5),

where each connecting device (5, 5', 5'') is sustained, at one side, by means of the fixed structure (3) and is fastened, at the other side, in a localised area of the respective pane (2, 2'), and where each pane (2, 2') has at least an edge that is contiguous to the edge of another pane (2, 2'), between the contiguous edge-

es sealing means (6, 7) being provided, **characterised in that** the window or door system comprises

- at least a first of said panes (2'), which is capable of moving (2') relative to said plane of lay and with which first sealing means (7) co-operate, able to be driven to pass from a respective operative condition to a respective inoperative condition, and vice versa,
- first actuating means (14) are provided, able to be selectively operated to determine the passage of said first sealing means (7) between the respective operative and inoperative conditions.

25. Window or door system according to claim 24, having one or more of the characteristics set out in claims 2 through 23.

26. Structural façade (1) comprising

- a plurality of panes or the like (2, 2'), in particular made of a transparent material, locally suspended in side by side positions substantially according to a same plane of lay,
- a fixed structure (3) where to support means (4, 5, 5', 5'') for the panes (2, 2') are associated, the support means (4, 5, 5', 5'') of each pane (2, 2') comprising a plurality of connecting devices (5),

where each connecting device (5, 5', 5'') is sustained, at one side, by means of the fixed structure (3) and is fastened, at the other side, in a localised area of the respective pane (2, 2'), and where each pane (2, 2') has at least an edge that is contiguous to the edge of another pane (2, 2'), between the contiguous edges sealing means (6, 7) being provided, **characterised in that**

- the connecting device (5', 5'') fastened to a first (2') of said panes (2, 2') comprise at least

- a first connecting device (5') fastened in a through hole present in the first pane (2') and supported in an articulated fashion by said fixed structure (3), and
- a second connecting device (5'') associated to a movable element (15A) able to be selectively operated to cause the displacement of said first pane (2') relative to said plane of lay;

- said sealing means (6,7) comprise first sealing means (7) co-operating with said first pane (2') and able to be driven to pass from a respective operative condition to a respective inoperative condition, and vice versa,

- first actuating means (14) are provided, able

to be selectively operated to determine the passage of the first sealing means (7) between the respective operative and inoperative conditions.

27. Window or door system for a structural façade (1), comprising

- a plurality of panes or the like (2, 2'), in particular made of a transparent material, locally suspended in side by side positions substantially according to a same plane of lay,
- a fixed structure (3) whereto support means (4, 5, 5', 5'') for the panes (2, 2') are associated, the support means (4, 5, 5', 5'') of each pane (2, 2') comprising a plurality of connecting devices (5),

where each connecting device (5, 5', 5'') is sustained, at one side, by means of the fixed structure (3) and is fastened, at the other side, in a localised area of the respective pane (2, 2'), and where each pane (2, 2') has at least an edge that is contiguous to the edge of another pane (2, 2'), between the contiguous edges sealing means (6, 7) being provided, the window or door system being **characterised in that**

- the connecting devices (5', 5'') fastened to a first (2') of said panes (2, 2') comprise at least
 - one connecting device (5') fastened in a through hole present in the first pane (2') and supported in articulated fashion by said fixed structure (3), and
 - a second connecting device (5'') associated to a movable element (15A) able to be selectively operated to cause the displacement of said first pane (2') relative to said plane of lay;
- said sealing means (6,7) comprise first sealing means (7) co-operating with said first pane (2') and able to be driven to pass from a respective operative condition to a respective inoperative condition, and vice versa,
- first actuating means (14) are provided, able to be selectively operated to determine the passage of the first sealing means (7) between the respective operative and inoperative conditions.

Patentansprüche

1. Strukturfassade (1), welche umfasst

- eine Vielzahl von Scheiben oder desgleichen (2, 2'), insbesondere aus transparentem Material hergestellt, lokal aufgehängt in Seitean-Seite-Positionen im Wesentlichen entsprechend ei-

ner gleichen Lageebene,

- eine befestigte Struktur (3), mit der Stützmittel (4, 5, 5', 5'') für die Scheiben (2, 2') verbunden sind, wobei die Stützmittel (4, 5, 5', 5'') von jeder Scheibe (2, 2') eine Vielzahl von Verbindungsvorrichtungen (5) umfassen,

wobei jede Verbindungsvorrichtung (5, 5', 5'') an einer Seite mit Hilfe der befestigten Struktur (3) getragen wird und an der anderen Seite in einem ortsgebundenen Bereich der entsprechenden Scheibe (2, 2') befestigt ist und wobei jede Scheibe (2, 2') wenigstens eine Kante aufweist, die angrenzend an die Kante der anderen Scheibe (2, 2') angrenzend ist, wobei zwischen den angrenzenden Kanten Dichtungsmittel (6, 7) vorgesehen sind, **dadurch gekennzeichnet, dass**

- wenigstens eine erste der Scheiben (2') fähig ist sich relativ zu der Lageebene zu bewegen (2'),
- die Dichtungsmittel (6, 7) erste Dichtungsmittel (7) umfassen, die mit der ersten Scheibe (2') zusammenwirken und betätigt werden können, um von einem entsprechenden betriebsfähigen Zustand in einen entsprechenden nicht-betriebsfähigen Zustand überzugehen und umgekehrt,
- wobei erste Betätigungsmittel (14) vorgesehen sind, die wahlweise betätigt werden können, um den Durchlass der ersten Dichtungsmittel (7) zwischen dem entsprechenden betriebsfähigen und nicht-betriebsfähigen Zustand zu bestimmen.

2. Fassade gemäß Anspruch 1, **dadurch gekennzeichnet, dass** in dem betriebsfähigen Zustand die ersten Dichtungsmittel (7) wenigstens zum Teil betriebsfähig sind, um die erste Scheibe (2') in der Lageebene zu halten.

3. Fassade gemäß Anspruch 1, **dadurch gekennzeichnet, dass** zweite Betätigungsmittel (15) vorgesehen sind, die wahlweise betätigt werden können, um die Versetzung der ersten Scheibe (2') relativ zu der Lageebene zu verursachen, wobei insbesondere in dem betriebsfähigen Zustand der ersten Dichtungsmittel (7) die zweiten Betätigungsmittel (15) betriebsfähig sind, um die erste Scheibe (2') in der Lageebene zu halten.

4. Fassade gemäß Anspruch 1, **dadurch gekennzeichnet, dass** die Verbindungsvorrichtungen (5, 5''), die an der ersten Scheibe (2') befestigt sind, wenigstens eine erste Verbindungsvorrichtung (5') umfassen, die in einer gelenkbildenden Art und Weise von der befestigten Struktur (3) gestützt wird.

5. Fassade gemäß Anspruch 1, **dadurch gekennzeichnet, dass** die Verbindungsvorrichtungen (5, 5''), die an der ersten Scheibe (2') befestigt sind, wenigstens eine zweite Verbindungsvorrichtung (5'') umfassen, die mit einem beweglichen Element (15A) verbunden ist, das durch das zweite Betätigungsmittel (15) betätigt wird.
6. Fassade gemäß Anspruch 4 und 5, **dadurch gekennzeichnet, dass** die erste Verbindungsvorrichtung (5') in einer Durchgangsbohrung befestigt ist, die in einem Bereich der ersten Scheibe (2') festgelegt ist, die derjenigen, in der die zweite Verbindungsvorrichtung (5'') befestigt ist, gegenüberliegt.
7. Fassade gemäß Anspruch 1, **dadurch gekennzeichnet, dass** die befestigte Struktur (3) ein Lagermittel (20) stützt, auf dem die erste Scheibe (2') direkt oder indirekt in Kontakt gehalten wird, wenn die Scheibe selbst in der Lageebene, wobei die Lagermittel insbesondere wenigstens ein Element (20) umfassen, das einen Kopf aufweist, der aus elastischem Material (20A) hergestellt ist, auf das ein ortsgewundener Bereich der Oberfläche der ersten Scheibe (2') gelegt werden kann.
8. Fassade gemäß Anspruch 1, **dadurch gekennzeichnet, dass** die ersten Dichtungsmittel einen Dichtungsring (7) umfassen, wobei insbesondere in dem nicht-betriebsfähigen Zustand der Dichtungsring (7) einen größeren Grad an Verformbarkeit aufweist, als wenn der Dichtungsring in dem betriebsfähigen Zustand ist.
9. Fassade gemäß Anspruch 8, **dadurch gekennzeichnet, dass** der Dichtungsring (7) aus elastischem Material hergestellt ist und eine innere Aushöhlung (7A) umfasst, wobei die Aushöhlung geeignet ist, um ein unter Druck stehendes Fluid zu beinhalten, wenn der Dichtungsring in dem betriebsfähigen Zustand ist.
10. Fassade gemäß Anspruch 8, **dadurch gekennzeichnet, dass** der Dichtungsring (7) wenigstens teilweise mit einem formgedächtnisaktiven Material hergestellt ist, wie einem Formgedächtnispolymer, und/oder Stützmittel aufweist, die wenigstens teilweise mit einem formgedächtnisaktiven Material gebaut sind, wie einem Formgedächtnispolymer.
11. Fassade gemäß Anspruch 9, **dadurch gekennzeichnet, dass** die ersten Betätigungsmittel einen Druckluftkompressor (14) umfassen, insbesondere mit der Aushöhlung (7A) verbunden mit Hilfe eines Kanals (19).
12. Fassade gemäß Anspruch 10, **dadurch gekennzeichnet, dass** die ersten Betätigungsmittel Mittel umfassen, die betriebsfähig sind, um die Erhitzung des aktiven Materials zu verursachen.
13. Fassade gemäß Anspruch 3, **dadurch gekennzeichnet, dass** die zweiten Mittel einen Aktuator (15) umfassen, insbesondere von der Kettenart (15A).
14. Fassade gemäß Anspruch 1 oder 3, **dadurch gekennzeichnet, dass** wenigstens eines der ersten Betätigungsmittel (14) und zweiten Betätigungsmittel (15) von einem Kontrollsystem (16) kontrolliert wird.
15. Fassade gemäß Anspruch 14, **dadurch gekennzeichnet, dass** die ersten Betätigungsmittel (14), die zweiten Betätigungsmittel (15) und das Kontrollsystem (16) in einer gleichen Einheit (10) enthalten sind, insbesondere getragen von der befestigten Struktur (3).
16. Fassade gemäß Anspruch 1 oder 3, **dadurch gekennzeichnet, dass** elektrische Batteriemittel (13) vorgesehen sind, die geeignet sind, um die ersten und/oder zweiten Betätigungsmittel (14, 15) mit Energie zu versorgen.
17. Fassade gemäß Anspruch 16, **dadurch gekennzeichnet, dass** die Batteriemittel von der wiederaufladbaren Art sind und dass eine oder mehrere photovoltaische Zellen (18) betriebsfähig mit den Batteriemitteln (13) verbunden sind, wobei die Zelle oder die Zellen Teil einer Anordnung sind, um die Batteriemittel wiederaufzuladen.
18. Fassade gemäß Anspruch 14, **dadurch gekennzeichnet, dass** das Kontrollsystem (16) einen Empfänger (17) von Fernsteuerungssignalen beinhaltet, um den Betrieb der ersten und/oder zweiten Betätigungsmittel (14, 15) zu steuern.
19. Fassade gemäß Anspruch 14, **dadurch gekennzeichnet, dass** das Kontrollsystem (16) Hubanschlagmittel umfasst, die betriebsfähig sind, um die Reichweite von einer bestimmten Position durch die erste Scheibe (2') zu erkennen oder zu bestimmen, wobei die Hubanschlagmittel insbesondere wenigstens eines umfassen von:
- ersten Hubanschlagmitteln, die betriebsfähig sind, um die Reichweite eines maximalen Grades an Versetzung der ersten Scheibe (2') in Bezug auf die Lageebene zu erkennen oder zu bestimmen,
 - zweiten Hubanschlagmitteln, die betriebsfähig sind, um die Reichweite, durch die erste Scheibe (2'), von einer vordefinierten Schließposition zu erkennen oder zu bestimmen.

20. Fassade gemäß wenigstens einem der vorhergehenden Ansprüche, **dadurch gekennzeichnet, dass** die Kante von wenigstens entweder der ersten Scheibe (2') oder einer zweiten Scheibe (2), die angrenzend dazu ist, geformt ist, um eine Einschnürung oder Pfanne festzulegen, um einen entsprechenden Abschnitt des Dichtungsring (7) zu beherbergen. 5
21. Fassade gemäß wenigstens einem der vorhergehenden Ansprüche, **dadurch gekennzeichnet, dass** der Dichtungsring (7) an wenigstens entweder die erste Scheibe (2') oder eine zweite Scheibe (2), die dazu angrenzend ist, angebracht ist. 10
22. Fassade gemäß wenigstens einem der vorhergehenden Ansprüche, **dadurch gekennzeichnet, dass** die ersten Betätigungsmittel und/oder die zweiten Betätigungsmittel Aktuatoren umfassen, die ausgewählt sind aus der Gruppe bestehend aus elektrischen Aktuatoren, pneumatischen Aktuatoren, hydraulischen Aktuatoren, manuellen Aktuatoren. 20
23. Fassade gemäß wenigstens einem der vorhergehenden Ansprüche, **dadurch gekennzeichnet, dass** die erste Scheibe (2') beweglich angebracht ist, um winkelförmige Bewegungen um eine im Wesentlichen horizontale Achse oder um eine im Wesentlichen vertikale Achse zu bewirken. 25
24. Fenster- oder Türsystem für eine Strukturfassade (1), welche umfasst 30
- eine Vielzahl von Scheiben oder desgleichen (2, 2'), insbesondere aus transparentem Material hergestellt, lokal aufgehängt in Seitenan-Seiten-Positionen im Wesentlichen entsprechend einer gleichen Lageebene, 35
 - eine befestigte Struktur (3), mit der Stützmittel (4, 5, 5', 5") für die Scheiben (2, 2') verbunden sind, wobei die Stützmittel (4, 5, 5', 5") von jeder Scheibe (2, 2') eine Vielzahl von Verbindungsvorrichtungen (5) umfassen, 40
- wobei jede Verbindungsvorrichtung (5, 5', 5") auf einer Seite mit Hilfe der befestigten Struktur (3) getragen wird und auf der anderen Seite in einem ortsgelassenen Bereich der entsprechenden Scheibe (2, 2') befestigt ist und wobei jede Scheibe (2, 2') wenigstens eine Kante aufweist, die angrenzend an die Kante der anderen Scheibe (2, 2') ist, wobei zwischen den angrenzenden Kanten Dichtungsmittel (6, 7) vorgesehen sind, **dadurch gekennzeichnet, dass** das Fenster- oder Türsystem umfasst 45
- wenigstens eine erste der Scheiben (2'), die (2') geeignet ist, um sich relativ zu der Lageebene zu bewegen und mit dem erste Dichtungsmittel (7) zusammenwirkt, das angetrieben werden kann, um aus einem entsprechenden betriebsfähigen Zustand in einen entsprechenden nicht-betriebsfähigen Zustand überzugehen und umgekehrt, 50
 - wobei erste Betätigungsmittel (14) vorgesehen sind, die wahlweise betätigt werden können, um den Durchlass der ersten Dichtungsmittel (7) zwischen dem entsprechenden betriebsfähigen oder nicht-betriebsfähigen Zustand zu bestimmen. 55
25. Fenster- oder Türsystem gemäß Anspruch 24, das eines oder mehrere der Merkmale aufweist, die in den Ansprüchen 2 bis 23 dargelegt sind.
26. Strukturfassade (1), welche umfasst
- eine Vielzahl von Scheiben oder desgleichen (2, 2'), insbesondere aus transparentem Material hergestellt, lokal aufgehängt in Seitenan-Seiten-Positionen im Wesentlichen entsprechend einer gleichen Lageebene,
 - eine befestigte Struktur (3), mit der Stützmittel (4, 5, 5', 5") für die Scheiben (2, 2') verbunden sind, wobei die Stützmittel (4, 5, 5', 5") von jeder Scheibe (2, 2') eine Vielzahl von Verbindungsvorrichtungen (5) umfassen,
- wobei jede Verbindungsvorrichtung (5, 5', 5") an einer Seite mit Hilfe der befestigten Struktur (3) getragen wird und an der anderen Seite in einem ortsgelassenen Bereich der entsprechenden Scheibe (2, 2') befestigt ist und wobei jede Scheibe (2, 2') wenigstens eine Kante aufweist, die angrenzend an die Kante der anderen Scheibe (2, 2') ist, wobei zwischen den angrenzenden Kanten Dichtungsmittel (6, 7) vorgesehen sind, **dadurch gekennzeichnet, dass**
- die Verbindungsvorrichtung (5', 5"), die befestigt ist an einer ersten (2') der Scheiben (2, 2'), wenigstens umfasst
 - eine erste Verbindungsvorrichtung (5'), die in einer Durchgangsbohrung befestigt ist, die in der ersten Scheibe (2') vorhanden ist, und in einer gelenkbildenden Art und Weise durch die befestigte Struktur (3) gestützt wird, und
 - eine zweite Verbindungsvorrichtung (5"), die mit einem beweglichen Element (15A) verbunden ist, das wahlweise betätigt werden kann, um eine Versetzung der ersten Scheibe relativ zu der Lageebene zu verursachen;
 - wobei die Dichtungsmittel (6, 7) erste Dichtungsmittel (7) zusammenwirkt, das angetrieben werden kann, um aus einem entsprechenden betriebsfähigen Zustand in einen entsprechenden nicht-betriebsfähigen Zustand überzugehen und umgekehrt,

tungsmittel (7) umfassen, die mit der ersten Scheibe (2') zusammenwirken und angetrieben werden können, um aus einem entsprechenden betriebsfähigen Zustand in einen entsprechenden nicht-betriebsfähigen Zustand überzugehen und umgekehrt, 5
 - wobei erste Betätigungsmittel (14) vorgesehen sind, die wahlweise betätigt werden können, um den Durchlass der ersten Dichtungsmittel (7) zwischen dem entsprechenden betriebsfähigen und nicht-betriebsfähigen Zustand zu bestimmen. 10

27. Fenster- oder Türsystem für eine Strukturfassade (1), welche umfasst

- eine Vielzahl von Scheiben oder desgleichen (2, 2'), insbesondere aus transparentem Material hergestellt, lokal aufgehängt in Seitean-Seite-Positionen im Wesentlichen entsprechend einer gleichen Lageebene, 20
 - eine befestigte Struktur (3), mit der Stützmittel (4, 5, 5', 5'') für die Scheiben (2, 2') verbunden sind, wobei die Stützmittel (4, 5, 5', 5'') von jeder Scheibe (2, 2') eine Vielzahl von Verbindungsvorrichtungen (5) umfassen, 25

wobei jede Verbindungsvorrichtung (5, 5', 5'') an einer Seite mit Hilfe einer befestigten Struktur (3) aufgehängt ist und an der anderen Seite in einem ortsgewundenen Bereich der entsprechenden Scheibe (2, 2') befestigt ist und wobei jede Scheibe (2, 2') wenigstens eine Kante aufweist, die angrenzend an die Kante der anderen Scheibe (2, 2') ist, wobei zwischen den angrenzenden Kanten Dichtungsmittel (6, 7) vorgesehen sind, wobei das Fenster- oder Türsystem **dadurch gekennzeichnet ist, dass** 30

- die Verbindungsvorrichtungen (5', 5''), die an einer ersten (2') der Scheiben (2, 2') befestigt sind, wenigstens umfassen 40

- eine Verbindungsvorrichtung (5'), die in einer Durchgangsbohrung befestigt ist, die in der ersten Scheibe (2') vorhanden ist und in einer gelenkbildenden Art und Weise durch die befestigte Struktur (3) gestützt wird, und 45

- eine zweite Verbindungsvorrichtung (5''), die verbunden ist mit einem beweglichen Element (15A), das wahlweise betätigt werden kann, um die Versetzung der ersten Scheibe (2') relativ zu der Lageebene zu verursachen; 50

- wobei die Dichtungsmittel (6, 7) erste Dichtungsmittel (7) umfassen, die mit der ersten Scheibe (2') zusammenwirken und angetrieben

werden können, um aus einem entsprechenden betriebsfähigen Zustand in einen entsprechenden nicht-betriebsfähigen Zustand überzugehen und umgekehrt,
 - wobei erste Betätigungsmittel (14) vorgesehen sind, die wahlweise betätigt werden können, um den Durchlass der ersten Dichtungsmittel (7) zwischen dem entsprechenden betriebsfähigen und nicht-betriebsfähigen Zustand zu bestimmen. 10

Revendications

1. Façade structurelle (1) comprenant : 15

- une pluralité de panneaux ou analogues (2, 2'), en particulier faits de matériau transparent, suspendus localement dans des positions côte à côte sensiblement selon un même plan de pose,
 - une structure fixe (3) à laquelle sont associés des moyens de support (4, 5, 5', 5'') pour les panneaux (2, 2'), les moyens de support (4, 5, 5', 5'') de chaque panneau (2, 2') comprenant une pluralité de dispositifs de liaison (5), 25

où chaque dispositif de liaison (5, 5', 5'') est soutenu, au niveau d'un côté, au moyen de la structure fixe (3) et est fixé, au niveau de l'autre côté, dans une zone localisée du panneau respectif (2, 2'), et où chaque panneau (2, 2') a au moins un bord qui est contigu au bord d'un autre panneau (2, 2'), des moyens d'étanchéité (6, 7) étant fournis entre les bords contigus, **caractérisée en ce que** 30

- au moins un premier desdits panneaux (2') est capable de se déplacer (2') par rapport audit plan de pose,

- lesdits moyens d'étanchéité (6,7) comprennent des premiers moyens d'étanchéité (7) coopérant avec ledit premier panneau (2') et capables d'être actionnés pour passer d'une condition opérationnelle respective à une condition non opérationnelle respective, et vice versa,

- des premiers moyens d'actionnement (14) sont fournis, capables d'être actionnés de façon sélective pour déterminer le passage des premiers moyens d'étanchéité (7) entre les conditions opérationnelle et non opérationnelle respectives. 35

2. Façade selon la revendication 1, caractérisée en ce que, dans ladite condition opérationnelle, lesdits premiers moyens d'étanchéité (7) sont au moins en partie opérationnels pour maintenir ledit premier panneau (2') dans ledit plan de pose. 55

3. Façade selon la revendication 1, **caractérisée en ce que** des seconds moyens d'actionnement (15) sont fournis, capables d'être actionnés de façon sélective pour entraîner le déplacement dudit premier panneau (2') par rapport audit plan de pose, où en particulier, dans ladite condition opérationnelle desdits premiers moyens d'étanchéité (7), lesdits seconds moyens actionneurs (15) sont opérationnels pour maintenir ledit premier panneau (2') dans ledit plan de pose. 5
4. Façade selon la revendication 1, **caractérisée en ce que** les dispositifs de liaison (5, 5") fixés audit premier panneau (2') comprennent au moins un premier dispositif de liaison (5') supporté de façon articulée par ladite structure fixe (3). 10
5. Façade selon la revendication 1, **caractérisée en ce que** les dispositifs de liaison (5, 5") fixés audit premier panneau (2') comprennent au moins un second dispositif de liaison (5") associé à un élément mobile (15A) actionné par lesdits seconds moyens d'actionnement (15). 20
6. Façade selon les revendications 4 et 5, **caractérisée en ce que** le premier dispositif de liaison (5') est fixé dans un trou débouchant défini dans une zone dudit premier panneau (2') qui est opposée à celle dans laquelle est fixé le second dispositif de liaison (5"). 25
7. Façade selon la revendication 1, **caractérisée en ce que** ladite structure fixe (3) supporte des moyens d'appui (20) sur lesquels ledit premier panneau (2') est maintenu directement ou indirectement en contact lorsque le panneau lui-même dans ledit plan de pose, lesdits moyens d'appui comprenant en particulier au moins un élément (20) ayant une tête faite de matériau élastique (20A), sur laquelle peut être établie une zone localisée de la surface dudit premier panneau (2'). 30
8. Façade selon la revendication 1, **caractérisée en ce que** lesdits premiers moyens d'étanchéité comprennent un joint statique (7), où en particulier, dans ladite condition non opérationnelle, ledit joint statique (7) a un degré plus important d'aptitude à la déformation que lorsque le joint statique est dans ladite condition opérationnelle. 35
9. Façade selon la revendication 8, **caractérisée en ce que** ledit joint statique (7) est fait de matériau élastique et comprend une cavité intérieure (7A), ladite cavité étant capable de contenir un fluide sous pression lorsque le joint statique est dans ladite condition opérationnelle. 40
10. Façade selon la revendication 8, **caractérisée en ce que** ledit joint statique (7) est au moins en partie fait avec un matériau actif à mémoire de forme, tel qu'un polymère à mémoire de forme, et/ou a des moyens de support qui sont au moins en partie construits avec un matériau actif à mémoire de forme, tel qu'un polymère à mémoire de forme. 45
11. Façade selon la revendication 9, **caractérisée en ce que** lesdits premiers moyens d'actionnement comprennent un générateur d'air comprimé (14), en particulier raccordé à ladite cavité (7A) au moyen d'un conduit (19). 50
12. Façade selon la revendication 10, **caractérisée en ce que** lesdits premiers moyens d'actionnement comprennent des moyens opérationnels pour entraîner le chauffage dudit matériau actif. 55
13. Façade selon la revendication 3, **caractérisée en ce que** lesdits seconds moyens comprennent un actionneur (15), en particulier du type chaîne (15A).
14. Façade selon la revendication 1 ou 3, **caractérisée en ce que** au moins un desdits premiers moyens d'actionnement (14) et des seconds moyens d'actionnement (15) est commandé par un système de commande (16).
15. Façade selon la revendication 14, **caractérisée en ce que** lesdits premiers moyens d'actionnement (14), lesdits seconds moyens d'actionnement (15) et ledit système de commande (16) sont compris dans une même unité (10), en particulier soutenue par ladite structure fixe (3).
16. Façade selon la revendication 1 ou 3, **caractérisée en ce que** des moyens de batterie électriques (13) sont fournis, capables de fournir une puissance électrique auxdits premiers et/ou seconds moyens d'actionnement (14, 15).
17. Façade selon la revendication 16, **caractérisée en ce que** lesdits moyens de batterie sont du type rechargeable et **en ce que** une ou plusieurs cellules photovoltaïques (18) sont connectées de façon opérationnelle auxdits moyens de batterie (13), ladite cellule ou lesdites cellules faisant partie d'un agencement pour recharger lesdits moyens de batterie.
18. Façade selon la revendication 14, **caractérisée en ce que** ledit système de commande (16) comprend un récepteur (17) de signaux de commande à distance, pour commander le fonctionnement desdits premiers et/ou seconds moyens d'actionnement (14, 15).
19. Façade selon la revendication 14, **caractérisée en ce que** ledit système de commande (16) comprend des moyens de fin de course, opérationnels pour

détecter ou déterminer l'atteinte d'une position déterminée par ledit premier panneau (2'), lesdits moyens de fin de course comprenant en particulier au moins un parmi :

- des premiers moyens de fin de course, opérationnels pour détecter ou déterminer l'atteinte d'un degré maximum de déplacement dudit premier panneau (2') par rapport audit plan de pose,
- des seconds moyens de fin de course, opérationnels pour détecter ou déterminer l'atteinte, par ledit premier panneau (2'), d'une position de fermeture prédéfinie.

20. Façade selon au moins l'une des revendications précédentes, **caractérisée en ce que** le bord d'au moins un entre ledit premier panneau (2') et un second panneau (2) contigu à celui-ci est formé pour définir une gorge ou un siège pour loger une partie respective dudit joint statique (7).

21. Façade selon au moins l'une des revendications précédentes, **caractérisée en ce que** ledit joint statique (7) est monté sur au moins un parmi ledit premier panneau (2') et un second panneau (2) contigu à celui-ci.

22. Façade selon au moins l'une des revendications précédentes, **caractérisée en ce que** lesdits premiers moyens actionneurs et/ou lesdits seconds moyens actionneurs comprennent des actionneurs sélectionnés parmi le groupe constitué d'actionneurs électriques, actionneurs pneumatiques, actionneurs hydrauliques, actionneurs manuels.

23. Façade selon au moins l'une des revendications précédentes, **caractérisée en ce que** ledit premier panneau (2') est monté de façon mobile pour effectuer des mouvements angulaires autour d'un axe sensiblement horizontal ou autour d'un axe sensiblement vertical.

24. Système de fenêtre ou porte pour une façade structurelle (1), comprenant :

- une pluralité de panneaux ou analogues (2, 2'), en particulier faits de matériau transparent, suspendus localement dans des positions côte à côte sensiblement selon un même plan de pose,
- une structure fixe (3) à laquelle sont associés des moyens de support (4, 5, 5', 5'') pour les panneaux (2, 2'), les moyens de support (4, 5, 5', 5'') de chaque panneau (2, 2') comprenant une pluralité de dispositifs de liaison (5),

où chaque dispositif de liaison (5, 5', 5'') est soutenu, au niveau d'un côté, au moyen de la structure fixe

(3) et est fixé, au niveau de l'autre côté, dans une zone localisée du panneau respectif (2, 2'), et où chaque panneau (2, 2') a au moins un bord qui est contigu au bord d'un autre panneau (2, 2'), des moyens d'étanchéité (6, 7) étant fournis entre les bords contigus, **caractérisée en ce que** le système de fenêtre ou porte comprend

- au moins un premier desdits panneaux (2'), qui est capable de se déplacer (2') par rapport audit plan de pose et avec lequel coopèrent des premiers moyens d'étanchéité (7), capables d'être entraînés pour passer depuis une condition opérationnelle respective jusqu'à une condition non opérationnelle respective, et vice versa,
- des premiers moyens d'actionnement (14) sont fournis, capables d'être actionnés de façon sélective pour déterminer le passage desdits premiers moyens d'étanchéité (7) entre les conditions opérationnelle et non opérationnelle respectives.

25. Système de fenêtre ou porte selon la revendication 24, ayant une ou plusieurs des caractéristiques présentées dans les revendications 2 à 23.

26. Façade structurelle (1) comprenant

- une pluralité de panneaux ou analogues (2, 2'), en particulier faits d'un matériau transparent, suspendus localement dans des positions côte à côte sensiblement selon un même plan de pose,
- une structure fixe (3) à laquelle sont associés des moyens de support (4, 5, 5', 5'') pour les panneaux (2, 2'), les moyens de support (4, 5, 5', 5'') de chaque panneau (2, 2') comprenant une pluralité de dispositifs de liaison (5),

où chaque dispositif de liaison (5, 5', 5'') est soutenu, au niveau d'un côté, au moyen de la structure fixe (3) et est fixé, au niveau de l'autre côté, dans une zone localisée du panneau respectif (2, 2'), et où chaque panneau (2, 2') a au moins un bord qui est contigu au bord d'un autre panneau (2, 2'), des moyens d'étanchéité (6, 7) étant fournis entre les bords contigus, **caractérisée en ce que**

- les dispositifs de liaison (5', 5'') fixés à un premier (2') desdits panneaux (2, 2') comprennent au moins
- un premier dispositif de liaison (5') fixé dans un trou débouchant présent dans le premier panneau (2') et supporté de façon articulée par ladite structure fixe (3), et
- un second dispositif de liaison (5'') associé à un élément mobile (15A) capable d'être actionné de façon sélective pour entraîner le déplacement

ment dudit premier panneau (2') par rapport audit plan de pose ;

- lesdits moyens d'étanchéité (6, 7) comprennent des premiers moyens d'étanchéité (7) coopérant avec ledit premier panneau (2') et capables d'être entraînés pour passer d'une condition opérationnelle respective à une condition non opérationnelle respective, et vice versa,
- des premiers moyens d'actionnement (14) sont fournis, capables d'être actionnés de façon sélective pour déterminer le passage des premiers moyens d'étanchéité (7) entre les conditions opérationnelle et non opérationnelle respectives.

5

10

15

27. Système de fenêtre ou porte pour une façade structurale (1), comprenant :

- une pluralité de panneaux ou analogues (2, 2'), en particulier faits d'un matériau transparent, suspendus localement dans des positions côte à côte sensiblement selon un même plan de pose,
- une structure fixe (3) à laquelle sont associés des moyens de support (4, 5, 5', 5'') pour les panneaux (2, 2'), les moyens de support (4, 5, 5', 5'') de chaque panneau (2, 2') comprenant une pluralité de dispositifs de liaison (5),

20

25

où chaque dispositif de liaison (5, 5', 5'') est soutenu, au niveau d'un côté, au moyen de la structure fixe (3) et est fixé, au niveau de l'autre côté, dans une zone localisée du panneau respectif (2, 2'), et où chaque panneau (2, 2') a au moins un bord qui est contigu au bord d'un autre panneau (2, 2'), des moyens d'étanchéité (6, 7) étant fournis entre les bords contigus, le système de fenêtre ou porte étant **caractérisée en ce que**

30

35

- les dispositifs de liaison (5', 5'') fixés à un premier (2') desdits panneaux (2, 2') comprennent au moins
- un dispositif de liaison (5') fixé dans un trou débouchant présent dans le premier panneau (2') et supporté de façon articulée par ladite structure fixe (3), et
- un second dispositif de liaison (5'') associé à un élément mobile (15A) capable d'être actionné de façon sélective pour entraîner le déplacement dudit premier panneau (2') par rapport audit plan de pose ;
- lesdits moyens d'étanchéité (6, 7) comprennent des premiers moyens d'étanchéité (7) coopérant avec ledit premier panneau (2') et capables d'être entraînés pour passer d'une condition opérationnelle respective à une condition non opérationnelle respective, et vice versa,
- des premiers moyens d'actionnement (14) sont

40

45

50

55

fournis, capables d'être actionnés de façon sélective pour déterminer le passage des premiers moyens d'étanchéité (7) entre les conditions opérationnelle et non opérationnelle respectives.

Fig.1

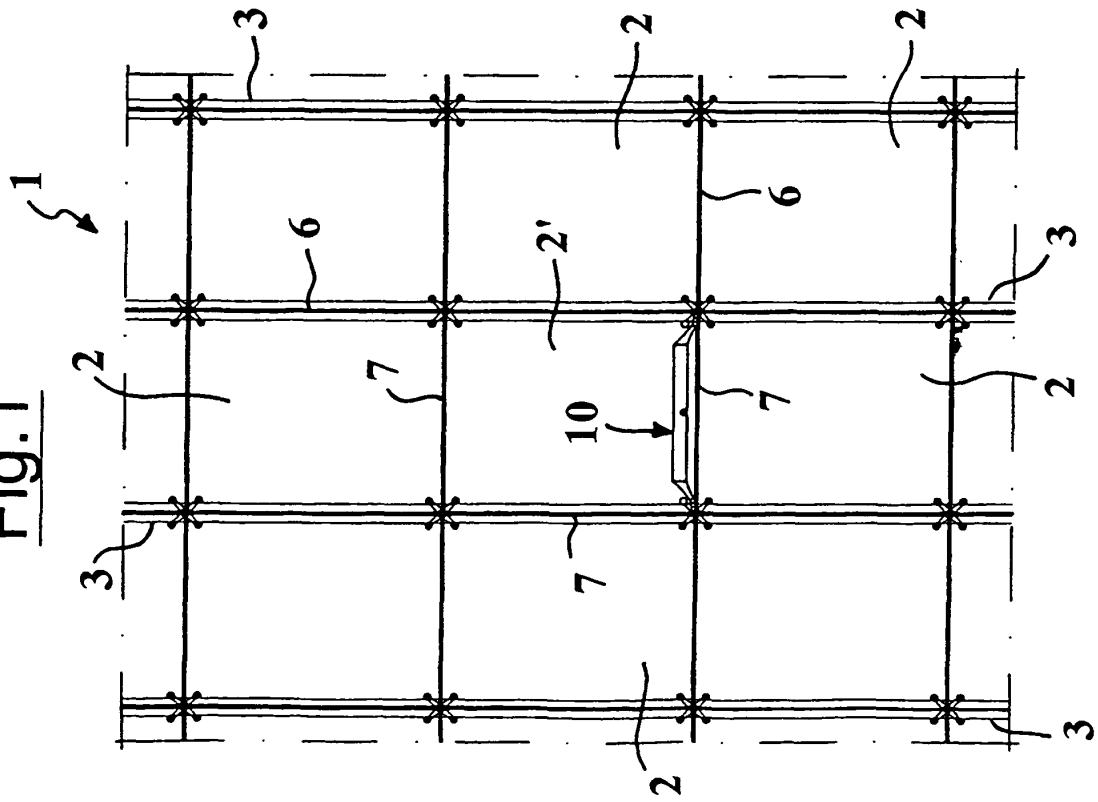
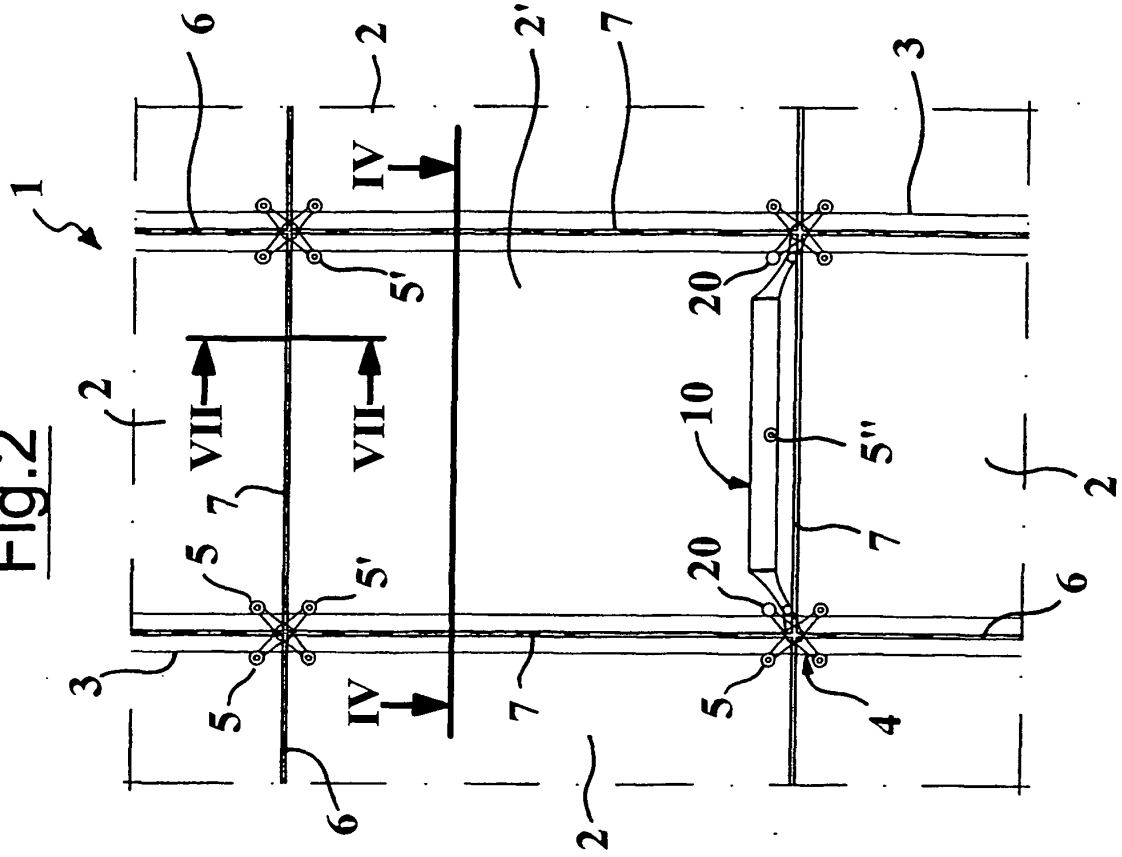

Fig.2



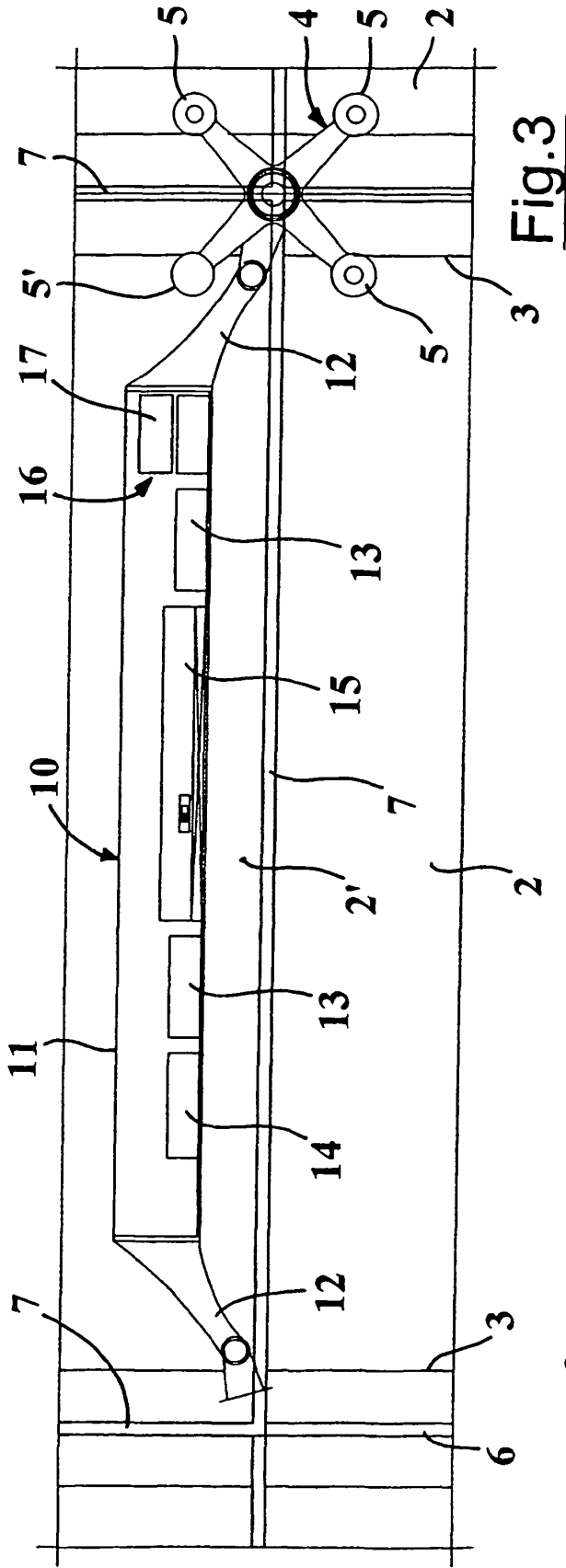

Fig. 3

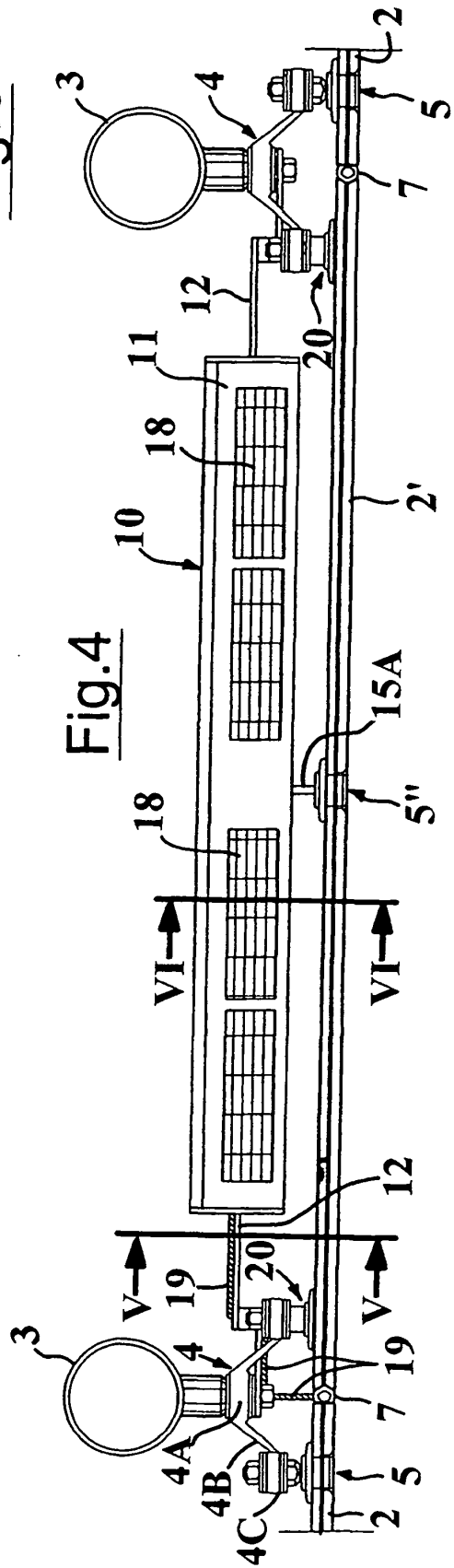

Fig. 4

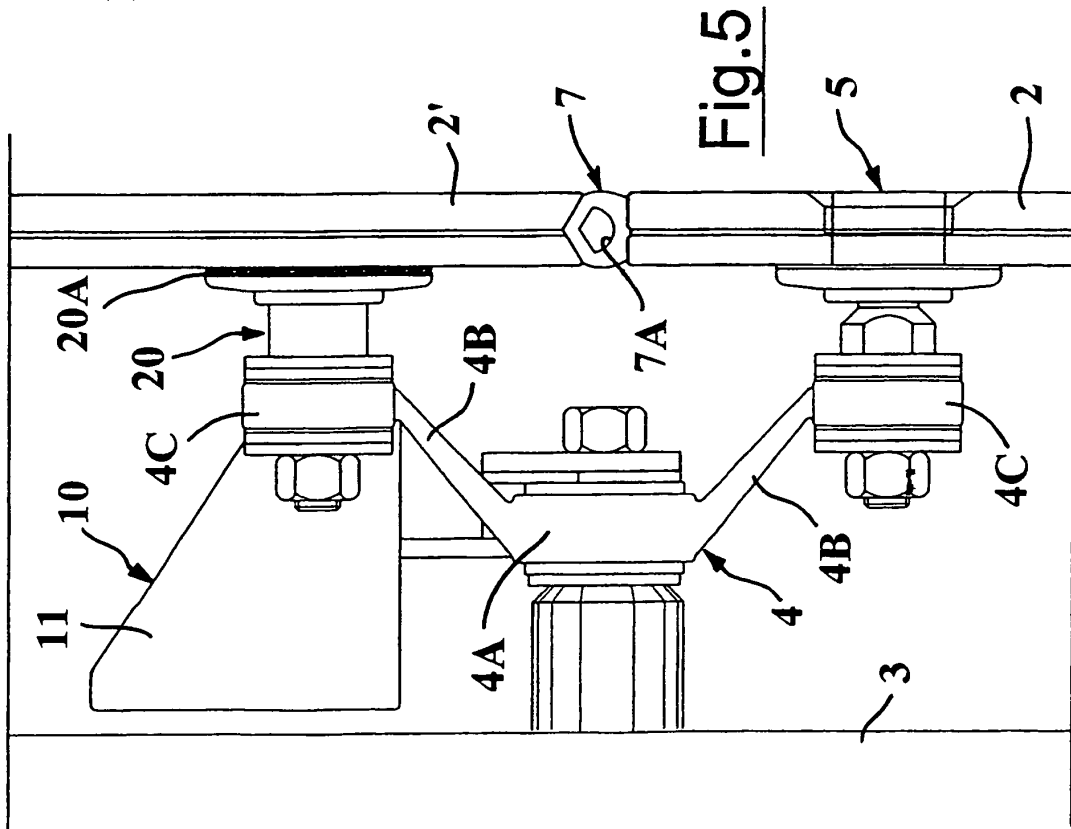

Fig. 5

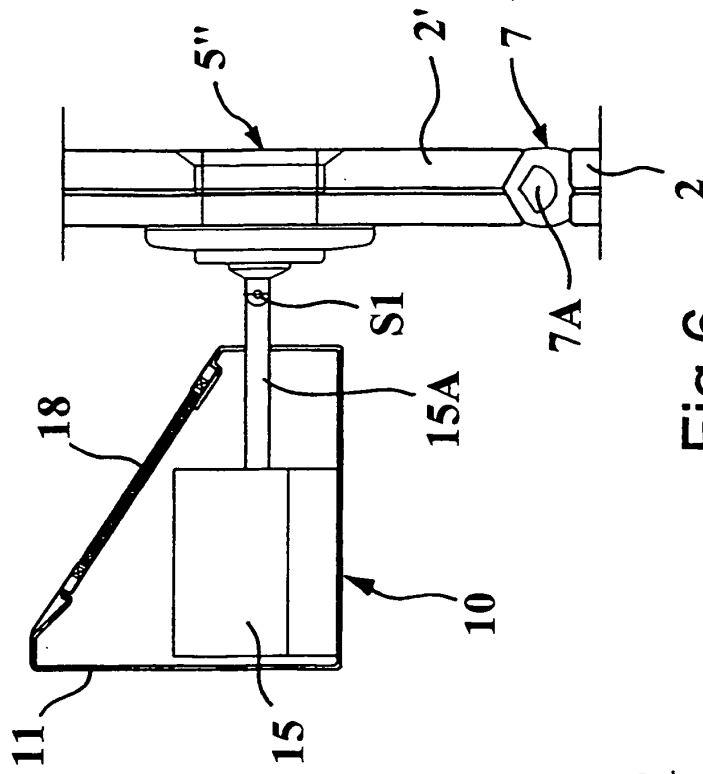

Fig. 6

Fig.9

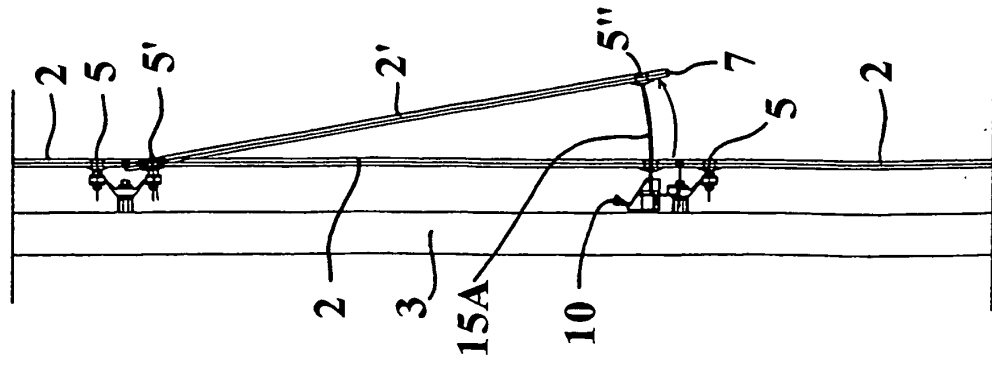

Fig.8

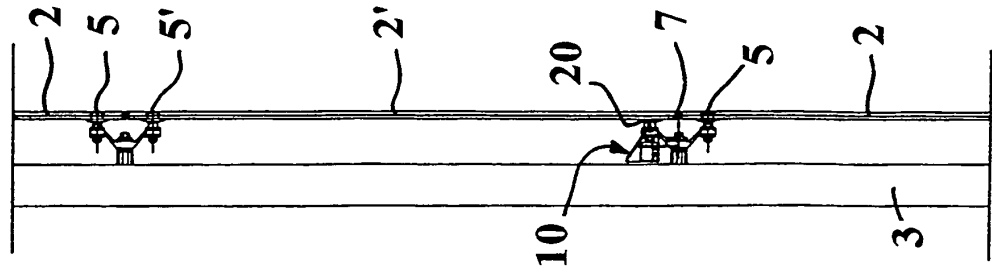

Fig.7

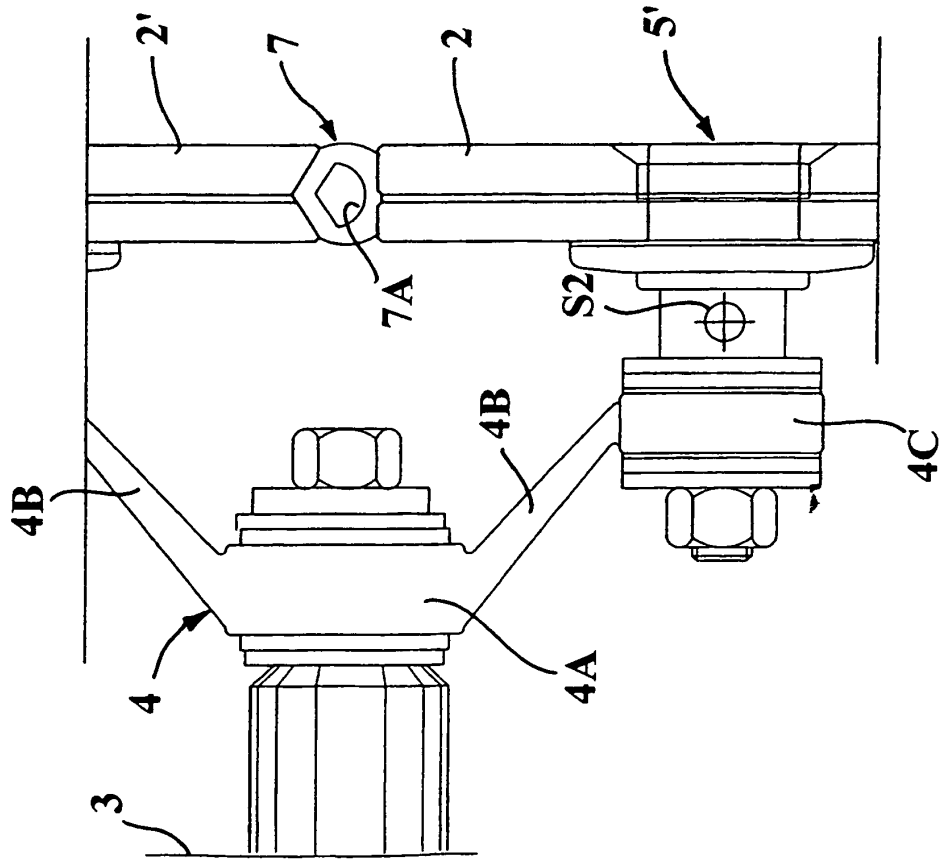

Fig.10

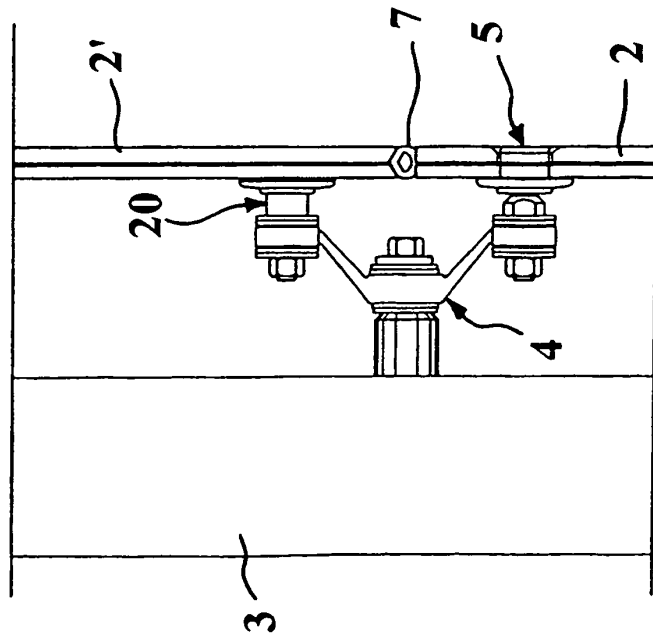

Fig.11

