

(19) World Intellectual Property Organization
International Bureau



(43) International Publication Date
23 October 2003 (23.10.2003)

PCT

(10) International Publication Number
WO 03/088247 A2

(51) International Patent Classification⁷: G11B 20/12, 20/18, 20/00

(21) International Application Number: PCT/IB03/01269

(22) International Filing Date: 1 April 2003 (01.04.2003)

(25) Filing Language: English

(26) Publication Language: English

(30) Priority Data: 02076518.6 18 April 2002 (18.04.2002) EP

(71) Applicant (for all designated States except US): KONINKLIJKE PHILIPS ELECTRONICS N.V. [NL/NL]; Groenewoudseweg 1, NL-5621 BA Eindhoven (NL).

(72) Inventors; and

(75) Inventors/Applicants (for US only): BENTVELSEN, Petrus, H., C. [NL/NL]; c/o Prof. Holstlaan 6, NL-5656 AA Eindhoven (NL). VOLLEBREGT, Paulus, F. [NL/NL]; c/o Prof. Holstlaan 6, NL-5656 AA Eindhoven (NL).

(74) Agent: DEGUELLE, Wilhelmus, H., G.; internationaal Octrooibureau B.V., Prof. Holstlaan 6, NL-5656 AA Eindhoven (NL).

(81) Designated States (national): AE, AG, AL, AM, AT, AU, AZ, BA, BB, BG, BR, BY, BZ, CA, CH, CN, CO, CR, CU, CZ, DE, DK, DM, DZ, EC, EE, ES, FI, GB, GD, GE, GH, GM, HR, HU, ID, IL, IN, IS, JP, KE, KG, KP, KR, KZ, LC, LK, LR, LS, LT, LU, LV, MA, MD, MG, MK, MN, MW, MX, MZ, NI, NO, NZ, OM, PH, PL, PT, RO, RU, SC, SD, SE, SG, SK, SL, TJ, TM, TN, TR, TT, TZ, UA, UG, US, UZ, VC, VN, YU, ZA, ZM, ZW.

(84) Designated States (regional): ARIPO patent (GH, GM, KE, LS, MW, MZ, SD, SL, SZ, TZ, UG, ZM, ZW), Eurasian patent (AM, AZ, BY, KG, KZ, MD, RU, TJ, TM), European patent (AT, BE, BG, CH, CY, CZ, DE, DK, EE, ES, FI, FR, GB, GR, HU, IE, IT, LU, MC, NL, PT, RO, SE, SI, SK, TR), OAPI patent (BF, BJ, CF, CG, CI, CM, GA, GN, GQ, GW, ML, MR, NE, SN, TD, TG).

Published:

— without international search report and to be republished upon receipt of that report

For two-letter codes and other abbreviations, refer to the "Guidance Notes on Codes and Abbreviations" appearing at the beginning of each regular issue of the PCT Gazette.

(54) Title: READ-ONLY RECORD CARRIER WITH RECORDABLE AREA IN SUBCODE CHANNEL

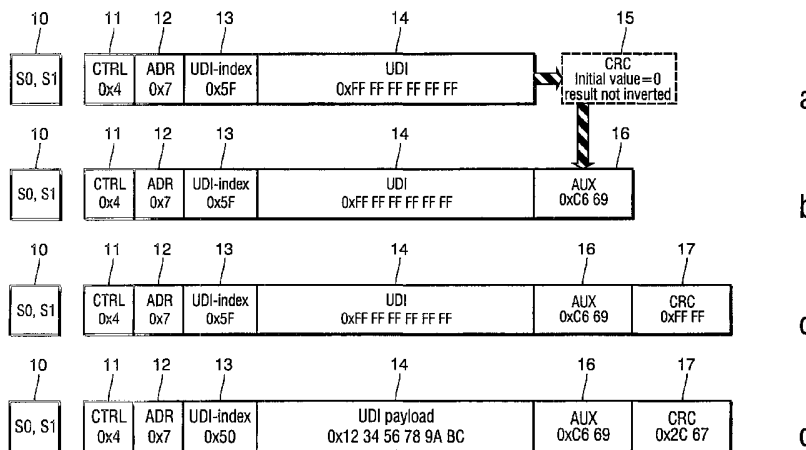

(57) Abstract: The invention relates to a method of providing a read-only record carrier on which user data can be recorded at predetermined recordable positions of subcode frames of a subcode channel after mastering of said record carrier, comprising the steps of: setting the subcode symbols at said predetermined recordable positions to a first predetermined symbol value during mastering, calculating for each subcode frame error detection data over certain subcode data of said subcode frame including said subcode symbols set to said first predetermined symbol value, storing said error detection data at auxiliary data positions in said subcode frame, and setting error detection data positions in said subcode frame to a second predetermined symbol value, said predetermined recordable positions of said subcode frames being provided for recording of user data to it during writing of data and said error detection data positions of said subcode frames being provided for recording correct error detection data calculated after recording said user data to said predetermined recordable positions to it.



WO 03/088247 A2

READ-ONLY RECORD CARRIER WITH RECORDABLE AREA IN SUBCODE CHANNEL

The invention relates to a method and an apparatus for providing a read-only record carrier on which user data can be recorded at predetermined recordable positions of subcode frames of a subcode channel after mastering of said record carrier. The invention relates further to a method and an apparatus of writing user data onto such a read-only record carrier, to a computer program for implementing said methods and to a record carrier mastered according to said method.

It is often desired that even on a read-only record carrier such as a CD-audio or CD-ROM after mastering certain user data can be stored on the record carrier. In particular, it is desired to generate a unique identifier of said record carrier by the distributor or sales point of said record carrier and/or to provide copy protection data on said record carrier mainly to prevent a user from making unauthorized copies of said record carrier or to enable replay devices to distinguish between an original and a copy of a record carrier.

It is therefore an object of the present invention to provide a read-only record carrier on which user data can be recorded after mastering. In addition, a corresponding method of writing user data to such a record carrier shall be provided.

Said object is achieved according to the present invention by a method as claimed in claim 1, comprising the steps of:

- setting the subcode symbols at said predetermined recordable positions to a first predetermined symbol value during mastering,
- calculating for each subcode frame error detection data over certain subcode data of said subcode frame including said subcode symbols set to said first predetermined symbol value,
- storing said error detection data at auxiliary data positions in said subcode frame, and
- setting error detection data positions in said subcode frame to a second predetermined symbol value,

said predetermined recordable positions of said subcode frames being provided for recording of user data to it during writing of data and said error detection data positions of said subcode

frames being provided for recording correct error detection data calculated after recording said user data to said predetermined recordable positions to it.

A method of writing user data to such a record carrier is claimed in claim 7, comprising the steps of:

- recording of user data to said predetermined recordable positions of said subcode frames during writing of data, and
- recording of correct error detection data calculated after recording said user data to said error detection data positions of said subcode frames.

Corresponding apparatuses according to the present invention are claimed in claims 8 and 9. A computer program for implementing the methods according to the invention is claimed in claim 10. A record carrier according to the present invention is defined in claim 11. Preferred embodiments and further developments of the invention are defined in the dependent claims.

The present invention is based on the idea to provide a possibility to modify certain symbols of the subcode channel even after mastering the record carrier. Therefore, the symbols at predetermined recordable positions of subcode frames and error detection data positions are set to a predetermined value which can be changed after mastering. However, in order to achieve that the error detection data is always correct, both after mastering, i.e. before writing of said particular user data, and after writing said user data, said error detection data are calculated after mastering. While the normal CRC is inverted and stored in the conventional CRC position, said data is not inverted and is stored in the auxiliary data positions. Said auxiliary data positions can but must not be recordable after mastering, so that in the latter case the values at said auxiliary data positions remain unchanged even after writing the user data at the recordable positions later.

According to a preferred embodiment said subcode channel is the Q-channel as defined in the Red Book for CD audio or as defined in the Yellow Book for CD-ROM. The error detection data thus preferably comprises cyclic redundancy check data which are preferably calculated over a control field, an address field and a user data field.

To enable the recording of user data even after mastering the subcode bytes comprise subcode symbols of all subcode channels, i.e. for CD audio of subcode channels P, Q, R, S, T, U, V, W. Said subcode bytes are set to value 0x47 during mastering so that the Q-channel symbol has bit value 1. Said value 0x47 can be easily changed into value 0x07 even after mastering so that the Q-channel symbol has bit value 0 by writing a mark at a predetermined position so that the pattern 3T pit - 3T land - 3T pit is modified into the pattern

9T pit. Preferably, merging bits are chosen such that the polarity of EFM word corresponding with 0x47 (corresponding EFM word is 00100100100100) starts with a 'pit'.

The invention will now be explained more in detail with reference to the drawings in which

Fig. 1 shows a block diagram of an encoder according to the present invention,

Fig. 2 illustrates the frame structure of the subcode channels in CD audio,

Fig. 3 illustrates the frame format of a Q-channel subcode frame,

Fig. 4 illustrates the method according to the present invention, and

Fig. 5 illustrates how user data can be recorded after mastering.

Fig. 1 shows a block diagram of an encoder according to the present invention as used during mastering of a disc. Content, such as audio, video or software data, is inputted into a main channel data unit 1 for processing, in particular encoding, said content into main channel data. Other information, in particular general data such as table of content (TOC) data and track time information is inputted into a subcode data unit 2 for processing, in particular encoding, said data into subcode data. An AUX calculator 3 which can be enabled or disabled is provided according to the present invention in the processing path of said subcode data which can be used to provide the possibility of writing user data at certain predetermined positions of a subcode channel even after mastering. Auxiliary (AUX) data positions are therefore provided in subcode frames of at least one subcode channel to which certain data will be recorded as will be explained below. Error detection data, in particular cyclic redundancy check (CRC) data are calculated for the subcode data to be stored in subcode frames by a CRC calculator 4. An EFM (Eight-to-Fourteen Modulation) modulator 5 converts the data of the main channel and the subchannels into channel bits of a data stream which is finally recorded on the disc by a laser beam recorder 6. The general layout and function of an encoder for recording data on an optical disc is well known and shall therefore not be described further. For particular details reference is made to standards for optical recording such as the Red Book for CD audio or the Yellow Book for CD-ROM.

Fig. 2 shows the well-known structure of EFM frames and subcode frames as used in CD audio. One frame F of channel bits comprises 98 EFM frames each comprising an EFM synchronization pattern, a subcode byte, user data bytes and error detection parities. The 98 subcode bytes together form a subcode data block S comprising 8 subcode frames of 8 different subcode channels, i.e. the P, Q, R, S, T, U, V, W subcode channel. Each subcode channel consists of 98 subcode bits that are built by 2 synchronization bits and 96 data bits.

Fig. 3 illustrates the data content of the subcode frame of the Q-channel in CD technology. In the shown non-limiting embodiment, the Q-subcode frame contains, in the following order, two synchronization pattern bits 202 which contain bits from special symbols S0 and S1 (2 bits), a control field 204 (CONTROL, 4 bits), an address field 206 (ADR, 4 bits), a track number field 208 (TNO, 8 bits), a track number index field 210 (X, 8 bits), a track time minutes field 212 (MIN, 8 bits), a track time seconds field 214 (SEC, 8 bits), a track time frame field 216 (FRAME, 8 bits), a field of zero bits 218 (ZERO, 8 bits), an absolute time minutes field 220 (A MIN, 8 bits), an absolute time seconds field 222 (A SEC, 8 bits), an absolute time frame field 224 (A FRAME, 8 bits), and a cyclic redundancy check field 226 (CRC, 16 bits).

With reference to Fig. 4 a particular embodiment of the present invention shall now be explained more in detail. Fig. 4a shows a simple layout of a subcode frame of the Q-channel. According to said layout the subcode frame comprises a synchronization field 10, a control field 11, an address field 12, a UDI (Unique Disc Identifier) index field 13 and a UDI field 14. The UDI field 14 is provided for storing a unique disc identifier uniquely identifying a particular disc. Such an UDI is often used in copy protection systems. In particular embodiments of replay devices said UDI is required to enable playback or copying of content stored on a disc. However, if it is detected that the disc that shall be played back or copied is not an original disc but an illegal copy then the output of the UDI can be suppressed so that playback or copying is not possible.

According to the present invention during mastering the UDI field 14 is set to 0xFF FF FF FF FF FF, i.e. all subcode bits of the UDI field 14 are set to bit value 1. Error detection data CRC are thereafter calculated over the control field 11, the address field 12, the UDI index field 13 and the UDI field 14. However, the calculated auxiliary CRC data 15 are not inverted and stored in an auxiliary data field 16 instead of the normal CRC field, as shown in Fig. 4b. During calculation of said auxiliary CRC data it is taken into account that the initial value is zero and the result is not inverted so that the CRC data stored in CRC data field 17 of the complete subcode frame shown in Fig. 4c has value 0xFF FF, i.e. all bits of the CRC data field 17 have bit value 1. Thus, the CRC stored in the CRC data field 17 is correct for the data stored in the remaining fields 11, 12, 13, 14 and 16 of the subcode frame after mastering.

According to the present invention at least the UDI field 14 and the CRC data field 17 are recordable after mastering, i.e. user data can be stored in the UDI field 14 and new corrected CRC data taking into account a new payload in the UDI field 14 can be

calculated and stored in the CRC data field 17. A user, e.g. the content owner or a sales person can assign a particular unique identifier UDI to the disc and store it in the UDI field 14 as shown in Fig. 4d. Thereafter the CRC data are again calculated over the control field 11, the address field 12, the UDI index field 13, the UDI field 14 and the AUX field 16, and the correct CRC data are stored in the CRC data field 17. Thus, the CRC data are correct before and after writing the user data into the UDI field 14. It is thus possible to use a stamper-unique identifier and an optional disc-unique identifier at the same time.

Fig. 5 illustrates how the writing of user bits after mastering is enabled. Fig. 5a shows the EFM synchronization pattern followed by two possibilities of three merging bits for polarity control, followed by a subcode byte comprising a subcode bit for each subcode channel, followed by a fixed merging bit pattern. To enable the writing of user bits into the subcode frame of the Q-channel the subcode byte is set to byte value 0x47 which channel word corresponds to data word 01000111 (=71 in decimal format). This means that the subcode bit for the Q-channel is set to bit value 1. Fig. 5a shows the pattern of pits and lands for said bit pattern.

To change the bit value of the subcode bit for the Q-channel the subcode byte value has to be changed from byte value 0x47 to 0x07, the bit pattern of which is shown at the bottom. Said subcode byte value 0x07 corresponds to a data word 00000111 (=7 in decimal format), i.e. the subcode bit of the Q-channel has bit value 0. This can be achieved by writing a 3T mark indicated by the arrow in Fig. 5b resulting in a pit and land pattern as shown in Fig. 5c. The sequence of 3T pit-3T land-3T pit shown in Fig. 5b is thus modified into the pattern 9T pit shown in Fig. 5c.

Fig. 5d shows the pit and land pattern before the recording of user data starting with the opposite polarity of the pits and lands and using a second merging bit pattern between the synchronization pattern and the subcode byte. Fig. 5e shows the pit and land pattern after changing the subcode byte from value 0x47 into 0x07.

It shall be noted that the present invention is not limited to the above-described embodiments. It can be applied to other record carriers as well, and it can be modified such that user data can also be stored in other subcode channels after mastering. Further, the number and the positions of recordable data bits within a subcode frame can be varied compared to the above-described embodiment. It could be provided that not only the UDI field 14 and the CRC data field 17 as shown in Fig. 4 can be modified after mastering, but that also the control field 11, the address field 12, the UDI-index field 13 and/or the auxiliary data field 16 can be modified after mastering.

CLAIMS:

1. Method of providing a read-only record carrier on which user data can be recorded at predetermined recordable positions of subcode frames of a subcode channel after mastering of said record carrier, comprising the steps of:
 - setting the subcode symbols at said predetermined recordable positions to a first predetermined symbol value during mastering,
 - calculating for each subcode frame error detection data over certain subcode data of said subcode frame including said subcode symbols set to said first predetermined symbol value,
 - storing said error detection data at auxiliary data positions in said subcode frame, and
 - setting error detection data positions in said subcode frame to a second predetermined symbol value,said predetermined recordable positions of said subcode frames being provided for recording of user data to it during writing of data and said error detection data positions of said subcode frames being provided for recording correct error detection data calculated after recording said user data to said predetermined recordable positions to it.
2. Method according to claim 1, wherein said first and said second predetermined symbol value is bit value 1.
3. Method as claimed in claim 1, wherein said user data comprise a unique identifier uniquely identifying said record carrier after recording said unique identifier at said predetermined recordable positions of said subcode frames.
4. Method as claimed in claim 1, wherein said subcode frames are part of a subcode Q-channel, particularly of an optical recording system for read-only optical discs.
5. Method as claimed in claim 4, wherein said subcode frames comprise a synchronization field, a control field, an address field, a user data field, an auxiliary data field

and an error detection data field of which at least said user data field and said error detection data field are recordable after mastering.

6. Method as claimed in claim 4, wherein subcode bytes comprising a subcode symbol from each subcode channel are set to byte value 0x47 during mastering so that for recording user data at said predetermined recordable positions said subcode bytes can be set to 0x07 by writing a mark at a predetermined location in said subcode byte.

7. Method of writing user data on a read-only record carrier at predetermined recordable positions of subcode frames of a subcode channel, wherein during mastering the subcode symbols at said predetermined recordable positions are set to a first predetermined symbol value, for each subcode frame error detection data are calculated over certain subcode data of said subcode frame including said subcode symbols set to said first predetermined symbol value, said error detection data are stored at auxiliary data positions in said subcode frame, and error detection data positions in said subcode frame are set to a second predetermined symbol value, comprising the steps of:

- recording of user data to said predetermined recordable positions of said subcode frames during writing of data, and
- recording of correct error detection data calculated after recording said user data to said error detection data positions of said subcode frames.

8. Apparatus for providing a read-only record carrier on which user data can be recorded at predetermined recordable positions of subcode frames of a subcode channel after mastering of said record carrier, comprising:

- means for setting the subcode symbols at said predetermined recordable positions to a first predetermined symbol value during mastering,
- means for calculating for each subcode frame error detection data over certain subcode data of said subcode frame including said subcode symbols set to said first predetermined symbol value,
- means for storing said error detection data at auxiliary data positions in said subcode frame, and
- means for setting error detection data positions in said subcode frame to a second predetermined symbol value,

said predetermined recordable positions of said subcode frames being provided for recording of user data to it during writing of data and said error detection data positions of said subcode frames being provided for recording correct error detection data calculated after recording said user data to said predetermined recordable positions to it.

9. Apparatus for writing user data on a read-only record carrier at predetermined recordable positions of subcode frames of a subcode channel, wherein during mastering the subcode symbols at said predetermined recordable positions are set to a first predetermined symbol value, for each subcode frame error detection data are calculated over certain subcode data of said subcode frame including said subcode symbols set to said first predetermined symbol value, said error detection data are stored at auxiliary data positions in said subcode frame, and error detection data positions in said subcode frame are set to a second predetermined symbol value, comprising:

- means for recording of user data to said predetermined recordable positions of said subcode frames during writing of data, and
- means for recording of correct error detection data calculated after recording said user data to said error detection data positions of said subcode frames.

10. Record carrier mastered according to a method as claimed in claim 1 on which user data can be recorded at predetermined recordable positions of subcode frames of a subcode channel after mastering of said record carrier, wherein:

- the subcode symbols at said predetermined recordable positions are set to a first predetermined symbol value,
- error detection data calculated for each subcode frame over certain subcode data of said subcode frame including said subcode symbols set to said first predetermined symbol value are stored at auxiliary data positions in said subcode frame, and
- error detection data positions in said subcode frame are set to a second predetermined symbol value,

said predetermined recordable positions of said subcode frames being provided for recording of user data to it during writing of data and said error detection data positions of said subcode frames being provided for recording correct error detection data calculated after recording said user data to said predetermined recordable positions to it.

11. Computer program for implementing a method as claimed in claim 1 or 7

comprising program code means for causing a computer to carry out the steps of said method when said method is run on a computer.

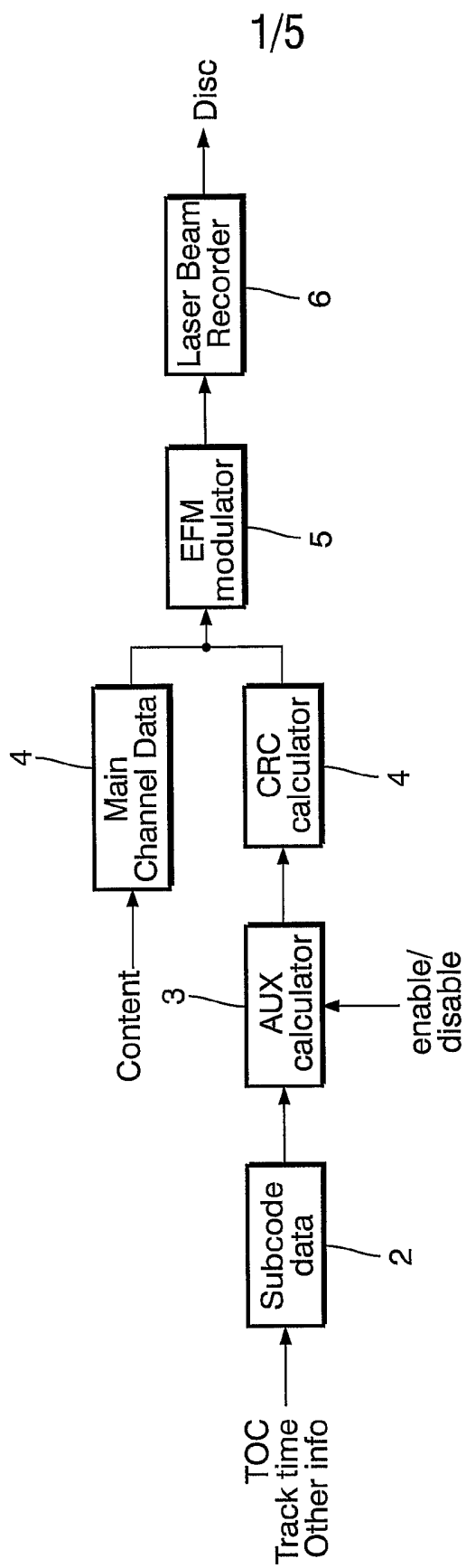

FIG.1

2/5

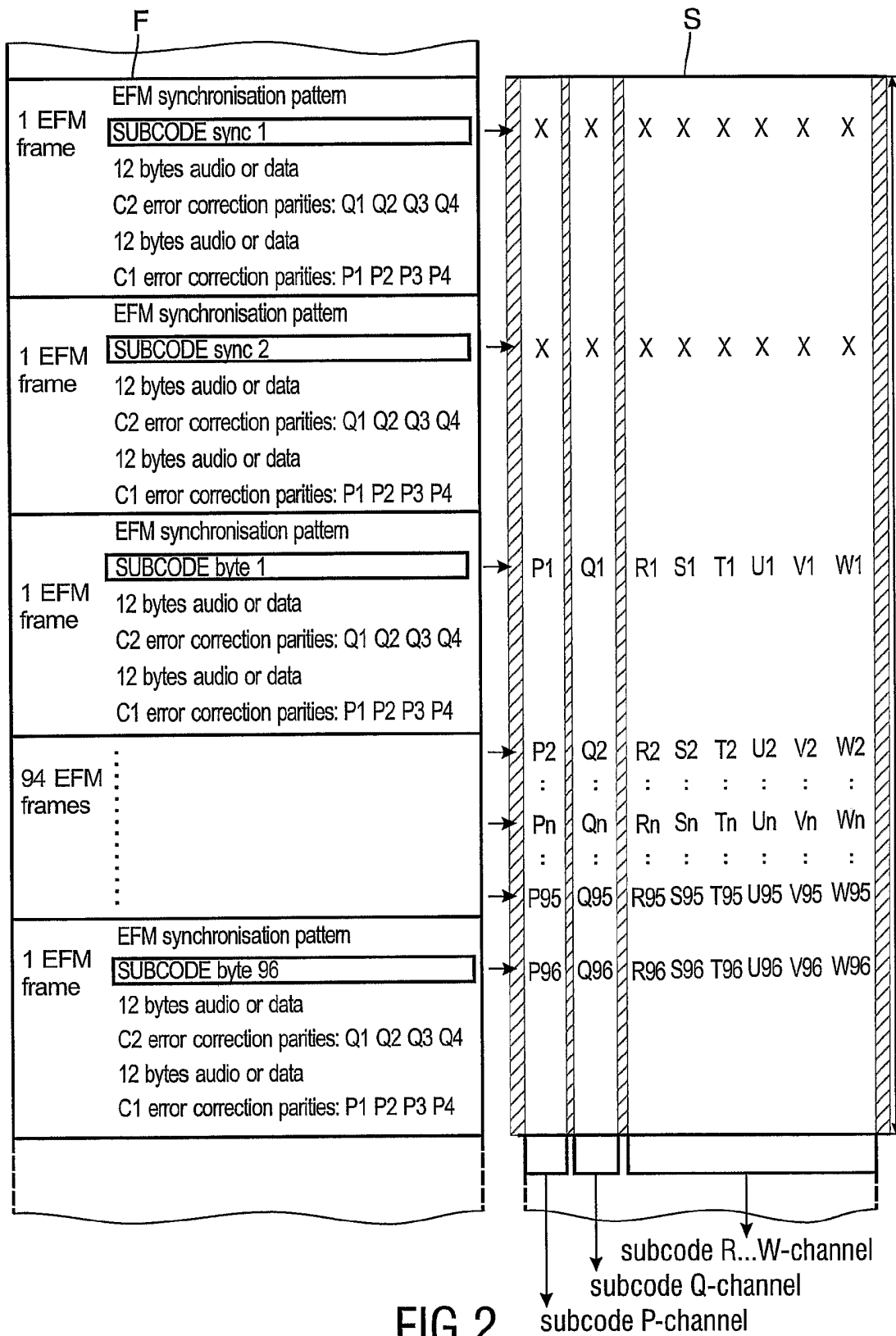

FIG.2

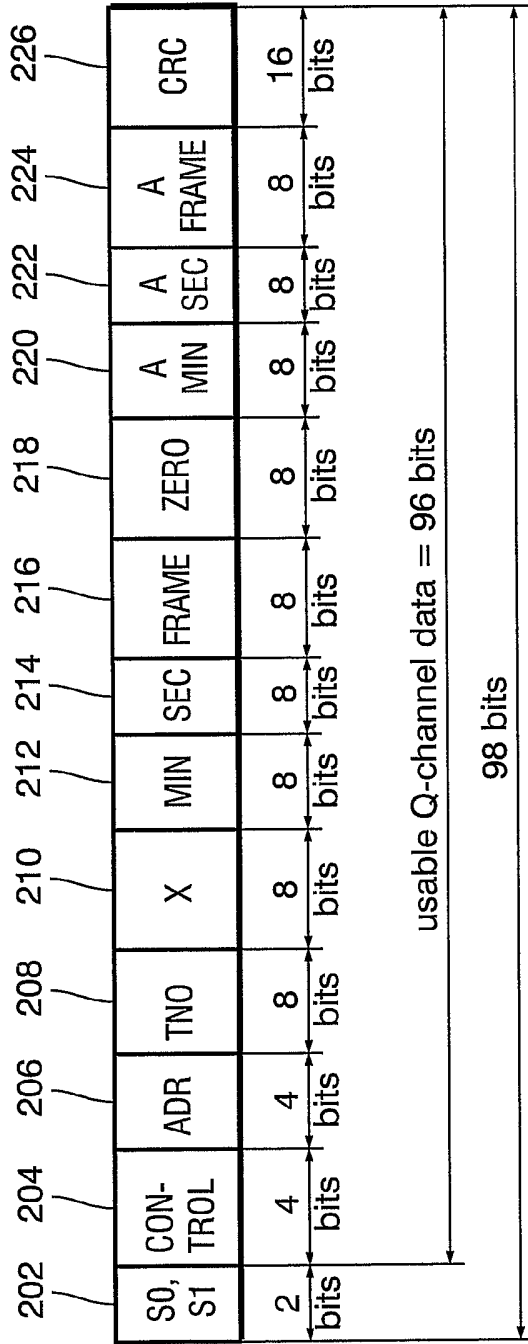

FIG.3

